

Phone: (505) 476-3441  
General Information  
Phone: (505) 629-6116

State of New Mexico  
Energy, Minerals and Natural Resources

Form C-103  
Revised July 18, 2013

Online Phone Directory Visit:  
<https://www.emnrd.nm.gov/ocd/contact-us/>

OIL CONSERVATION DIVISION  
1220 South St. Francis Dr.  
Santa Fe, NM 87505

WELL API NO. 30-015-58016
5. Indicate Type of Lease STATE <input type="checkbox"/> FEE <input type="checkbox"/>
6. State Oil & Gas Lease No.

<p><b>SUNDRY NOTICES AND REPORTS ON WELLS</b> (DO NOT USE THIS FORM FOR PROPOSALS TO DRILL OR TO DEEPEN OR PLUG BACK TO A DIFFERENT RESERVOIR. USE "APPLICATION FOR PERMIT" (FORM C-101) FOR SUCH PROPOSALS.)</p> <p>1. Type of Well: Oil Well <input checked="" type="checkbox"/> Gas Well <input type="checkbox"/> Other <input type="checkbox"/></p>		<p>7. Lease Name or Unit Agreement Name PINTAIL 23-35 FEDERAL COM</p>
<p>2. Name of Operator CIMAREX ENERGY CO. OF COLORADO</p>		<p>8. Well Number 13H</p>
<p>3. Address of Operator 6000 DEAUVILLE BLVD., 300N, MIDLAND TX 79706</p>		<p>9. OGRID Number 162683</p>
<p>4. Well Location Unit Letter <u>C</u> <u>389</u> feet from the <u>NORTH</u> line and <u>1899</u> feet from the <u>WEST</u> line Section <u>23</u> Township <u>25S</u> Range <u>26E</u> NMPM County</p>		<p>10. Pool name or Wildcat PURPLE SAGE; WOLFCAMP (GAS)</p>
<p>11. Elevation (Show whether DR, RKB, RT, GR, etc.)</p>		

12. Check Appropriate Box to Indicate Nature of Notice, Report or Other Data

<p><b>NOTICE OF INTENTION TO:</b></p> <p>PERFORM REMEDIAL WORK <input type="checkbox"/> PLUG AND ABANDON <input type="checkbox"/>          TEMPORARILY ABANDON <input type="checkbox"/> CHANGE PLANS <input checked="" type="checkbox"/>          PULL OR ALTER CASING <input type="checkbox"/> MULTIPLE COMPL <input type="checkbox"/>          DOWNHOLE COMMINGLE <input type="checkbox"/>          CLOSED-LOOP SYSTEM <input type="checkbox"/>          OTHER: <input type="checkbox"/></p>	<p><b>SUBSEQUENT REPORT OF:</b></p> <p>REMEDIAL WORK <input type="checkbox"/> ALTERING CASING <input type="checkbox"/>          COMMENCE DRILLING OPNS. <input type="checkbox"/> P AND A <input type="checkbox"/>          CASING/CEMENT JOB <input type="checkbox"/>          OTHER: <input type="checkbox"/></p>
--	--

13. Describe proposed or completed operations. (Clearly state all pertinent details, and give pertinent dates, including estimated date of starting any proposed work). SEE RULE 19.15.7.14 NMAC. For Multiple Completions: Attach wellbore diagram of proposed completion or recompletion.

Cimarex Energy Co. of Colorado (Coterra Energy Operating Co.) respectfully requests a variance to allow a testing schedule of the blow out prevention equipment (BOPE) along with Stump Testing and Batch Drilling operations on the intermediate casing for the Pintail 23-35 Federal Com 13H (API Number 30-015-58016). Please see the attached approved sundry filed with BLM, Revised Well Control Plan, 10M BOPE diagram, and BOPE Break Testing Variance PowerPoint.

Spud Date:

Rig Release Date:

I hereby certify that the information above is true and complete to the best of my knowledge and belief.

SIGNATURE Crystal Denson TITLE Regulatory Analyst DATE 4/3/2026

Type or print name Crystal Denson E-mail address: Crystal.Denson@coterra.com PHONE: 432.620.1699

**For State Use Only**

APPROVED BY: \_\_\_\_\_ TITLE \_\_\_\_\_ DATE \_\_\_\_\_

Conditions of Approval (if any):

Well Name	Well Number	US Well Number	Lease Number	Case Number	Operator
PINTAIL 23-35	17H		NMNM94076	NMNM94076	COTERRA
PINTAIL 23-35	19H		NMNM94076	NMNM94076	COTERRA
PINTAIL 23-35	11H		NMNM94076	NMNM94076	COTERRA
PINTAIL 23-35	12H		NMNM94076	NMNM94076	COTERRA
PINTAIL 23-35	13H		NMNM94076	NMNM94076	COTERRA
PINTAIL 23-35	16H		NMNM94076	NMNM94076	COTERRA

**Notice of Intent**

**Sundry ID:** 2904181

**Type of Submission:** Notice of Intent

**Type of Action:** APD Change

**Date Sundry Submitted:** 04/02/2026

**Time Sundry Submitted:** 02:18

**Date proposed operation will begin:** 04/02/2026

**Procedure Description:** Coterra Energy Operating Co. respectfully requests a variance to allow a testing schedule of the blow out prevention equipment (BOPE) along with Stump Testing and Batch Drilling operations on the intermediate casing. Please see the attached Revised Well Control Plan, 10M BOPE diagram, and BOPE Break Testing Variance PowerPoint. WELL NAME WELL NUMBER APD ID NUMBER PINTAIL 23-26-35 FEDERAL COM 11H 10400109453 PINTAIL 23-26-35 FEDERAL COM 12H 10400109580 PINTAIL 23-26-35 FEDERAL COM 13H 10400109581 PINTAIL 23-26-35 FEDERAL COM 16H 10400109582 PINTAIL 23-26-35 FEDERAL COM 17H 10400109583 PINTAIL 23-26-35 FEDERAL COM 19H 10400109584

**NOI Attachments**

**Procedure Description**

Coterra\_BOP\_Break\_Test\_Variance\_20260402141519.pdf

WELL\_CONTROL\_PLAN\_REV.1\_20260402141519.pdf

10M\_BOPE\_BLM\_SUBMISSION\_REV.0\_20260402141518.pdf

**Conditions of Approval**

**Specialist Review**

Variance\_20260403072841.pdf

**Operator**

*I certify that the foregoing is true and correct. Title 18 U.S.C. Section 1001 and Title 43 U.S.C. Section 1212, make it a crime for any person knowingly and willfully to make to any department or agency of the United States any false, fictitious or fraudulent statements or representations as to any matter within its jurisdiction. Electronic submission of Sundry Notices through this system satisfies regulations requiring a*

**Operator Electronic Signature:** CRYSTAL DENSON

**Signed on:** APR 02, 2026 03:11 PM

**Name:** COTERRA ENERGY OPERATING CO

**Title:** Regulatory Analyst

**Street Address:** 6001 DEAUVILLE BLVD SUITE 300N

**City:** MIDLAND

**State:** TX

**Phone:** (432) 620-1644

**Email address:** CRYSTAL.DENSON@COTERRA.COM

**Field**

**Representative Name:**

**Street Address:**

**City:**

**State:**

**Zip:**

**Phone:**

**Email address:**

**BLM Point of Contact**

**BLM POC Name:** LONG VO

**BLM POC Title:** Petroleum Engineer

**BLM POC Phone:** 5759885402

**BLM POC Email Address:** LVO@BLM.GOV

**Disposition:** Approved

**Disposition Date:** 04/03/2026

**Signature:** Long Vo

Form 3160-5  
(October 2024)

UNITED STATES  
DEPARTMENT OF THE INTERIOR  
BUREAU OF LAND MANAGEMENT

FORM APPROVED  
OMB No. 1004-0220  
Expires: October 31, 2027

**SUNDRY NOTICES AND REPORTS ON WELLS**  
**Do not use this form for proposals to drill or to re-enter an abandoned well. Use Form 3160-3 (APD) for such proposals.**

5. Lease Serial No.

6. If Indian, Allottee or Tribe Name

**SUBMIT IN TRIPLICATE - Other instructions on page 2**

7. If Unit of CA/Agreement, Name and/or No.

1. Type of Well

Oil Well     Gas Well     Other

8. Well Name and No.

2. Name of Operator

9. API Well No.

3a. Address

3b. Phone No. (include area code)

10. Field and Pool or Exploratory Area

4. Location of Well (Footage, Sec., T.,R.,M., or Survey Description)

11. Country or Parish, State

**12. CHECK THE APPROPRIATE BOX(ES) TO INDICATE NATURE OF NOTICE, REPORT OR OTHER DATA**

TYPE OF SUBMISSION	TYPE OF ACTION			
<input type="checkbox"/> Notice of Intent	<input type="checkbox"/> Acidize	<input type="checkbox"/> Deepen	<input type="checkbox"/> Production (Start/Resume)	<input type="checkbox"/> Water Shut-Off
<input type="checkbox"/> Subsequent Report	<input type="checkbox"/> Alter Casing	<input type="checkbox"/> Hydraulic Fracturing	<input type="checkbox"/> Reclamation	<input type="checkbox"/> Well Integrity
<input type="checkbox"/> Final Abandonment Notice	<input type="checkbox"/> Casing Repair	<input type="checkbox"/> New Construction	<input type="checkbox"/> Recomplete	<input type="checkbox"/> Other
	<input type="checkbox"/> Change Plans	<input type="checkbox"/> Plug and Abandon	<input type="checkbox"/> Temporarily Abandon	
	<input type="checkbox"/> Convert to Injection	<input type="checkbox"/> Plug Back	<input type="checkbox"/> Water Disposal	

13. Describe Proposed or Completed Operation: Clearly state all pertinent details, including estimated starting date of any proposed work and approximate duration thereof. If the proposal is to deepen directionally or recomplete horizontally, give subsurface locations and measured and true vertical depths of all pertinent markers and zones. Attach the Bond under which the work will be performed or provide the Bond No. on file with BLM/BIA. Required subsequent reports must be filed within 30 days following completion of the involved operations. If the operation results in a multiple completion or recompletion in a new interval, a Form 3160-4 must be filed once testing has been completed. Final Abandonment Notices must be filed only after all requirements, including reclamation, have been completed and the operator has determined that the site is ready for final inspection.)

14. I hereby certify that the foregoing is true and correct. Name (Printed/Typed)

Title

Signature

Date

**THE SPACE FOR FEDERAL OR STATE OFFICE USE**

Approved by

Title

Date

Conditions of approval, if any, are attached. Approval of this notice does not warrant or certify that the applicant holds legal or equitable title to those rights in the subject lease which would entitle the applicant to conduct operations thereon.

Office

Title 18 U.S.C Section 1001 and Title 43 U.S.C Section 1212, make it a crime for any person knowingly and willfully to make to any department or agency of the United States any false, fictitious or fraudulent statements or representations as to any matter within its jurisdiction.

(Instructions on page 2)

## GENERAL INSTRUCTIONS

This form is designed for submitting proposals to perform certain well operations and reports of such operations when completed as indicated on Federal and Indian lands pursuant to applicable Federal law and regulations. Any necessary special instructions concerning the use of this form and the number of copies to be submitted, particularly with regard to local area or regional procedures and practices, are either shown below, will be issued by or may be obtained from the local Federal office.

## SPECIFIC INSTRUCTIONS

*Item 4* - Locations on Federal or Indian land should be described in accordance with Federal requirements. Consult the local Federal office for specific instructions.

*Item 13*: Proposals to abandon a well and subsequent reports of abandonment should include such special information as is required by the local Federal office. In addition, such proposals and reports should include reasons for the abandonment; data on any former or present productive zones or other zones with present significant fluid contents not sealed off by cement or otherwise; depths (top and bottom) and method of placement of cement plugs; mud or other material placed below, between and above plugs; amount, size, method of parting of any casing, liner or tubing pulled and the depth to the top of any tubing left in the hole; method of closing top of well and date well site conditioned for final inspection looking for approval of the abandonment. If the proposal will involve **hydraulic fracturing operations**, you must comply with 43 CFR 3162.3-3, including providing information about the protection of usable water. Operators should provide the best available information about all formations containing water and their depths. This information could include data and interpretation of resistivity logs run on nearby wells. Information may also be obtained from state or tribal regulatory agencies and from local BLM offices.

## NOTICES

The privacy Act of 1974 and the regulation in 43 CFR 2.48(d) provide that you be furnished the following information in connection with information required by this application.

AUTHORITY: 30 U.S.C. 181 et seq., 351 et seq., 25 U.S.C. 396; 43 CFR 3160.

PRINCIPAL PURPOSE: The information is used to: (1) Evaluate, when appropriate, approve applications, and report completion of subsequent well operations, on a Federal or Indian lease; and (2) document for administrative use, information for the management, disposal and use of National Resource lands and resources, such as: (a) evaluating the equipment and procedures to be used during a proposed subsequent well operation and reviewing the completed well operations for compliance with the approved plan; (b) requesting and granting approval to perform those actions covered by 43 CFR 3162.3-2, 3162.3-3, and 3162.3-4; (c) reporting the beginning or resumption of production, as required by 43 CFR 3162.4-1(c) and (d) analyzing future applications to drill or modify operations in light of data obtained and methods used.

ROUTINE USES: Information from the record and/or the record will be transferred to appropriate Federal, State, local or foreign agencies, when relevant to civil, criminal or regulatory investigations or prosecutions in connection with congressional inquiries or to consumer reporting agencies to facilitate collection of debts owed the Government.

EFFECT OF NOT PROVIDING THE INFORMATION: Filing of this notice and report and disclosure of the information is mandatory for those subsequent well operations specified in 43 CFR 3162.3-2, 3162.3-3, 3162.3-4.

The Paperwork Reduction Act of 1995 requires us to inform you that:

The BLM collects this information to evaluate proposed and/or completed subsequent well operations on Federal or Indian oil and gas leases.

Response to this request is mandatory.

The BLM would like you to know that you do not have to respond to this or any other Federal agency-sponsored information collection unless it displays a currently valid OMB control number.

**BURDEN HOURS STATEMENT:** Public reporting burden for this form is estimated to average 8 hours per response, including the time for reviewing instructions, gathering and maintaining data, and completing and reviewing the form. Direct comments regarding the burden estimate or any other aspect of this form to U.S. Department of the Interior, Bureau of Land Management (1004-0137), Bureau Information Collection Clearance Officer (WO-630), 1849 C St., N.W., Mail Stop 401 LS, Washington, D.C. 20240

## Additional Information

### Batch Well Data

PINTAIL 23-35 FEDERAL COM 11H, US Well Number: null, Case Number: NMNM94076, Lease Number: NMNM94076,  
Operator:COTERRA ENERGY OPERATING CO

PINTAIL 23-35 FEDERAL COM 12H, US Well Number: null, Case Number: NMNM94076, Lease Number: NMNM94076,  
Operator:COTERRA ENERGY OPERATING CO

PINTAIL 23-35 FEDERAL COM 13H, US Well Number: null, Case Number: NMNM94076, Lease Number: NMNM94076,  
Operator:COTERRA ENERGY OPERATING CO

PINTAIL 23-35 FEDERAL COM 16H, US Well Number: null, Case Number: NMNM94076, Lease Number: NMNM94076,  
Operator:COTERRA ENERGY OPERATING CO

PINTAIL 23-35 FEDERAL COM 17H, US Well Number: null, Case Number: NMNM94076, Lease Number: NMNM94076,  
Operator:COTERRA ENERGY OPERATING CO

PINTAIL 23-35 FEDERAL COM 19H, US Well Number: null, Case Number: NMNM94076, Lease Number: NMNM94076,  
Operator:COTERRA ENERGY OPERATING CO

CONFIDENTIAL



# BOPE Break Testing Variance

Surface, Intermediate 1 & Intermediate 2  
Excludes Production Strings

March 26, 2026

## BOPE Break Test Variance (Less than 12,000' TVD)

- Coterra, in compliance with 43 CFR 3172.13(a), is respectfully pursuing a variance to the minimum standards to allow a testing schedule of the blow out prevention equipment (BOPE) along with Stump Testing, Batch Drilling & Offline Cementing operations to include the following:
- Company representatives will observe the job and ensure the following procedures are upheld ensuring that operational safety, environmental protection, and regulatory compliance is maintained
  - Coterra will utilize a hard shut-in for any portion of the drilling activity, a soft shut-in will be performed when shutting in on a well while running casing.
- Conduct a full 10M BOPE to 10,000 psi and a 5M Annular test to 5,000 psi upon initial installation on the pad.
  - If MASP is within 90% rating of the 5M annular, it will be replaced with a 10M annular.
- For rigs with permanent manufactured test stumps, in order to qualify for a variance all must apply
  - Must be manufactured for all of Coterra's 10M – 13 5/8" BOP's with a drill pipe threaded base
    - Built using AISI 4130 Steel.
  - Stump will support BX159 ring gaskets.
  - Comply with API 6A or 16A.
  - All certifications and charts will be managed by the rig contractor but available at all times.
- Perform full BOPE tests every 21 days thereafter.
- Intermediate Break-testing is permitted to the base of the Wolfcamp or shallower (limited to 12,000' TVD).

## BOPE Break Test Variance (Less than 12,000' TVD) (Continued)

- Once the well is secured and BLM has been notified, disconnect the BOP and walk the rig to the next well on the pad.
  - If any unusual events occur during drilling, tripping, or casing operations, break-testing will not be performed.
  - If offset fracturing is observed within 1.0 mile in the same producing horizon, break-testing in the production section will not be performed.
- Each rig requesting a break-test variance must be capable of picking up the BOP using winches, follow API Standard 53 (Fifth Edition, December 2018, Annex C, Table C.4), and do so without damaging components, to qualify break-testing as an acceptable practice.
  - Coterra will comply with API Standard 53 Table C.4 which requires testing to Rated Working Pressure (RWP)
- Weekly function tests will be performed on the following BOP elements:
  - Annular
  - 2x Pipe Rams
  - Blind Rams
- After securing the well section, disconnect the BOP from the wellhead and walk it with the rig to another well on the pad.
- Install a TA cap per Cactus Wellhead procedures and monitor casing pressure via the valve on the TA cap.
- Any well control event shall require a notification to the BLM engineer.

# NU/ND TA Cap

- Before releasing off the well a casing flow test will be performed to verify floats hold and the KWM
- BPV can be installed which was rebuilt and pressure tested per the manufacturers specifications
- BOPE will be nipped down and TA cap is installed

ID Casing Barrier	Rating	Backside Barrier	Rating
BPV	15,000psi	KWM	> BHP
KWM	> BHP	Packoff	10,000psi
Float Valves	10,000psi	WH Adapter	10,000psi

- Moving to the new well which will already have a BPV installed with a TA cap
- TA cap will be ND and the BOPE will be installed

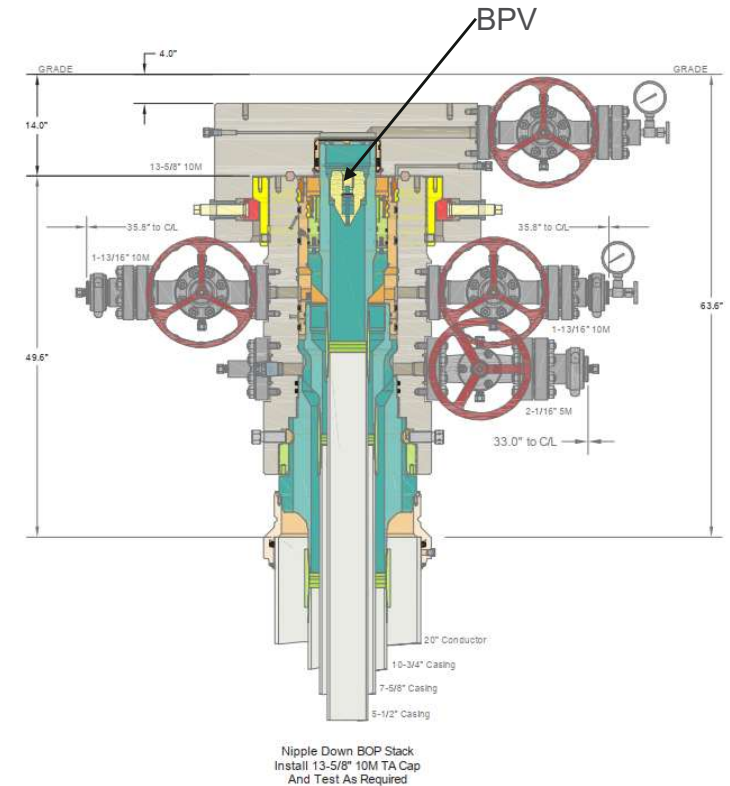

# BOPE Break Test Variance (Less than 12,000' TVD)

### Test Procedure:

1. Makeup test plug on DP and set in Wellhead.
2. Close Upper Pipe Rams around DP.
3. Close Kill Line & HCR.
4. Open wellhead valve to ensure if pressure leaks past plug, it won't pressure up wellbore.
5. Tie into top of DP at Rig Floor. Fill with water and test Break + Pipe Rams to 250psi low and 10,000psi high.
6. Bleed off pressure.
7. Open Upper Pipe Rams, close wellhead valve and lay down test plug and DP.

Components	Offline	Offline, BOPE	Break	Online
Annular		X	X	X
Upper Rams		X	X	X
Blind Rams		X		X
Lower Rams				X
Inside Kill Valve		X	X	X
Outside Kill Valve		X	X	X
Kill Line Valve		X	X	X
Kill Line	X			X
Inside Choke Valve		X	X	X
HCR		X	X	X
Choke Manifold	X			X
Mudline (Mud Pumps, Rig Floor Valves, Kelly Hose Mudline)	X			X
Standpipe Valve	X			X
IBOP (Upper & Lower)	X			X
Notes				

Coterra request offline BOPE testing for the following components: Annular, Upper Rams, Blind Rams, Kill Valves, & Choke Valves  
 Remaining well control equipment components will either be tested offline or online, per BLM approval  
 Remaining BOPE will be tested online within 72-hours from completing the offline BOPE component testing  
 Coterra will notify the BLM if the online BOPE testing exceeds 72-hours  
 All full test not completed 'Offline' or 'Offline, BOPE' are required to be completed Online  
 Any flex lines that are broken during the moving of the rig will be retested to full rated pressure

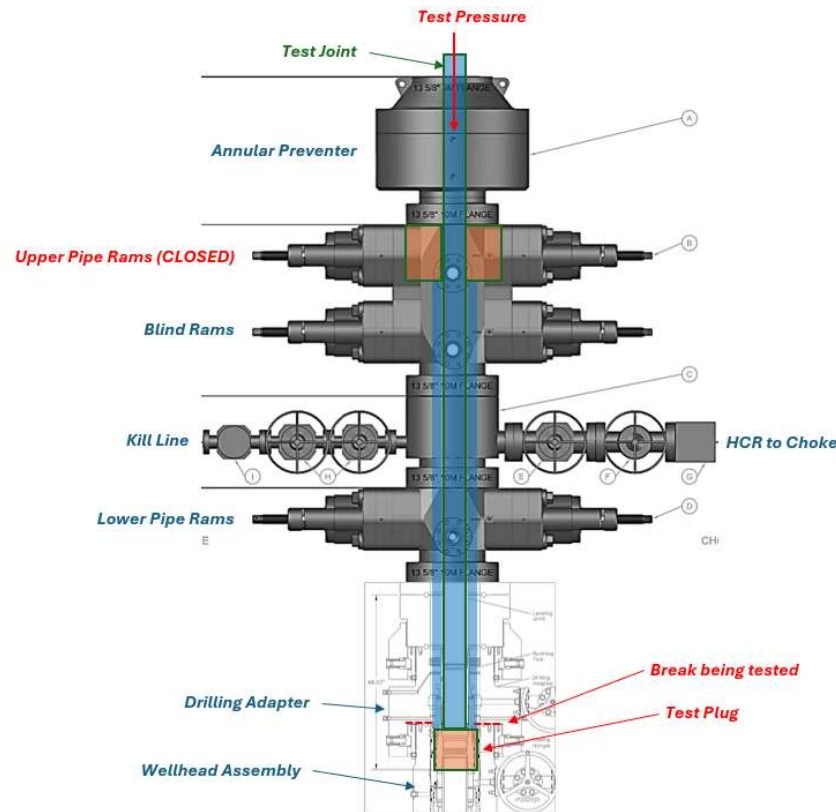



Thank You

Coterra: Well Control Plan



---

## Well Control Plan

---

### Warning Signs of a Kick

If a kick is ever suspected, perform flow check.

While Drilling:

1. Drilling break or increase in penetration rate
2. Increase of flow
3. Pit gain
4. Flow without pumping
5. Circulating pressure decrease and/or spm increase
6. Increase in gas cutting at the shakers
7. Decrease in cuttings at shakers

While Tripping:

1. Hole not taking the proper fill on trip out of hole
2. Hole returns too much mud on trip in hole
3. Flow without pumping

While Out of the Hole:

1. Flow
2. Pit gain

### Well Control Procedures with Diverter

A TIW valve in the open position must be on the rig floor at all times.

If rotating head is installed:

1. Perform flow check.
2. If well is flowing, divert flow down flow line and through separator, before returning across shakers.
3. Swap to 10 ppg brine and circulate around. Notify superintendent.

## Coterra: Well Control Plan

4. If well becomes uncontrollable, close annular, which will open HCR to divert flow away from rig.

If rotating head is not installed:

1. Perform flow check.
2. If well is flowing uncontrollably, close annular, which will open HCR to divert flow away from rig.
3. Swap to 10 ppg brine and circulate around. Notify superintendent.
4. After 10 ppg is circulated around shut pumps off and perform flow check.

## Well Control Procedures

Coterra follows a hard shut-in procedure. Choke will be in the closed position.

### *General Well Control*

1. If in doubt, secure the well first, then inform your supervisor.
2. Never wait for approval to shut in the well.
3. Verify that the mud pump is off before you close the BOP.
4. Always check and verify the well is properly secured after shut in.
5. Always install TIW valve in the open position.
6. If TIW valve is installed and then closed, apply estimated DP shut-in pressure above valve before opening.
7. The weak link in the mud system and mud lines is the pressure relief valve or pop off valve on the mud pump.
8. Keep the TIW valve wrench in a designated location on the rig floor and in the open position.
9. Use a drill string float above the bit. Don't perforate or disable the float.
10. In the event wellbore pressure encroaches to the maximum rated pressure of the annular, primary pressure control will be switched to the higher rated components (i.e., switch from annular to pipe rams) – upper pipe rams will be closed, and the annular opened in order to not exceed maximum rated pressures.

### *Hard Shut-In*

1. Remote choke is closed.
2. Stop pumping and space out.
3. Check for flow.
4. To shut in pipe ram.
5. Open the HCR valve.
6. Check systems, bump float. Record Initial Shut in Drill pipe pressure and Initial shut in casing pressure.

## Coterra: Well Control Plan

*Soft Shut-In for Annular on Casing*

1. Remote choke is opened.
2. Stop pumping and space out.
3. Check for flow.
4. To shut in, close annular.
5. Slowly close the HCR
6. Record shut-in pressure (SIDPP & SICP)
7. In the event wellbore pressure encroaches to the maximum rated pressure of the annular, primary pressure control will be switched to the higher rated components (i.e., switch from annular to pipe rams) – upper pipe rams will be closed, and the annular opened in order to not exceed maximum rated pressures.

*Flow Check when on Bottom*

1. Alert crew & stop rotating
2. Pick up and space out
3. Shut down pumps
4. Observe well for flow
5. Shut-in if flowing

*Shutting in while Drilling*

1. After flow has been detected via flow check, kill pumps, shut in well and open HCR
2. Verify well is shut-in and flow has stopped
3. Notify supervisory personnel
4. Record data
5. Begin go forward planning

*Flow Check while Tripping*

1. Alert crew & pick up / space out
2. Stop pipe movement. Set slips with tool joint accessible at rotary table
3. Install open TIW safety valve and close valve
4. Observe well for flow
5. Shut-in if flowing

*Shutting in while Tripping*

1. Install open TIW safety valve and close valve
2. Shut-in the well
3. Verify well is shut-in and flow has stopped
4. Install IBOP
5. Notify supervisory personnel
6. Record data; SICP, shut-in time, kick depth, and pit gain

## Coterra: Well Control Plan

7. Begin go forward planning

*Shutting in while Out of Hole*

1. Sound alarm
2. Shut-in well: close blind rams.
3. Verify well is shut-in and monitor pressures.
4. Notify supervisory personnel
5. Record data; SICP, shut-in time, kick depth, and pit gain
6. Begin go forward planning

*Information to Record while Shut-In*

1. Shut in drill pipe pressure every 5 minutes
2. Shut in casing pressure every 5 minutes
3. Pit gain
4. Total volume in pit system
5. Mud weight in suction pit
6. Current depth
7. Total depth
8. Time the well is shut in

*H2S with Annular Diverter:*

1. Kill Pumps, close annular, which will open HCR, to divert flow away from rig.
2. Muster and take head count.
3. Call ASSI to check location for H2S. Call Coterra superintendent.
4. After ASSI has checked for H2S the path forward will be decided from Coterra superintendent.

*H2S with BOP's:*

1. Kill pumps
2. Shut in annular with HCR open and chokes closed.
3. Muster and take head count.
4. Call ASSI to check location for H2S. Call Coterra superintendent.
5. After ASSI has checked for H2S. discuss path forward with Coterra superintendent

*Procedure for Closing Blind Rams*

- Open HCR valve (visually check that the HCR valve is open – stem in the valve is open, stem out the valve is closed).
- Verify all circulating pumps are off (mud pumps, trip tank pump, etc.)
- Ensure that the hydraulic choke is in the closed position.

## Coterra: Well Control Plan

- Close the blind rams and place the “blind rams closed, bleed pressure and remove hole cover before opening” sign on the console.
- Monitor the shut in casing pressure gauge periodically while the blinds are closed to ensure that wellbore pressure isn’t building. If pressure build up is observed, monitor the shut in casing pressure more frequently & document. Notify rig management and Coterra representative of the pressure build up.
- Ensure that the inner bushings are locked into the master bushings if applicable.
- Install hole cover.

### *Procedure for Opening Blind Rams*

- Make sure choke manifold is aligned correctly.
- Open the hydraulic choke to bleed any trapped pressure that may be under the blind rams. (Even if the casing pressure gauge is reading zero).
- Confirm that no flow is discharging into the trip tank or possum bellies of the shale shaker (wherever the separator is discharging into).
- Remove hole cover.
- Confirm that the inner bushing are locked into the master bushings if applicable.
- Clear all personnel from the rig floor.
- Remove sign and open blind rams.
- Return the BOPE to its original operating alignment.

### *BOP Drills*

- Drilling crews should conduct BOP drills weekly from BOP nipple up to TD for reaction time to properly simulate securing the well. Record BOP drills on that day’s report.
- Standard precautions such as checking the accumulator for proper working pressure, function testing rams, and recording slow pump rates are performed on a daily basis or on trips..
- All supervisory personnel onsite need to be properly trained and currently hold certification from an approved blowout prevention school. Any deviation from this needs to be discussed prior to spud.
- Drillers should always notify the tool pusher and the drilling foreman before performing a blowout drill.

### *Choke Manifold Freeze Prevention*

- When possible, blow out the choke & kill lines as well as the choke manifold with rig air to remove water based fluids.
- When clear water is being placed into the choke & kill line as well as the choke manifold, make sure that the water has a mixture of 30% methanol added.

## Coterra: Well Control Plan

- When applicable, choke & kill lines as well as choke manifold needs to be pumped through with the rig pump by the driller to ensure that the lines aren't plugged with settling barite or solids.

### *Ram Configuration*

In order from top to bottom (Deviation to this configuration requires a discussion with your engineer and superintendent).

- A. 5M Annular bag
    - Per API 53 5.1.3.1 a 5M Annular BOP will be used
  - B. 10M Top pipe rams
    - Top pipe rams may be VBR's to match drill pipe size being used or fixed to casing ran.
  - C. 10M Blind rams
  - D. Mud Cross
    - Kill Line Side: check valve and two manual valves (10M). The outer most manual valve is to be closed and the inner most valve is open under normal operations.
    - Choke Side: a manual valve and a HCR (hydraulic remote controlled valve) (10M). The manual valve is open and the HCR valve is closed under normal operations.
  - E. 10M VBR
    - Bottom pipe rams should match the drill pipe ran or appropriate sized VBR's (variable bore rams).
- Minimum bore diameter of BOP stack equipment shall be at least equal to the bore diameter of the uppermost casing head.
  - Flare line to be ran a minimum of 100' away from wellhead toward the edge of pad.

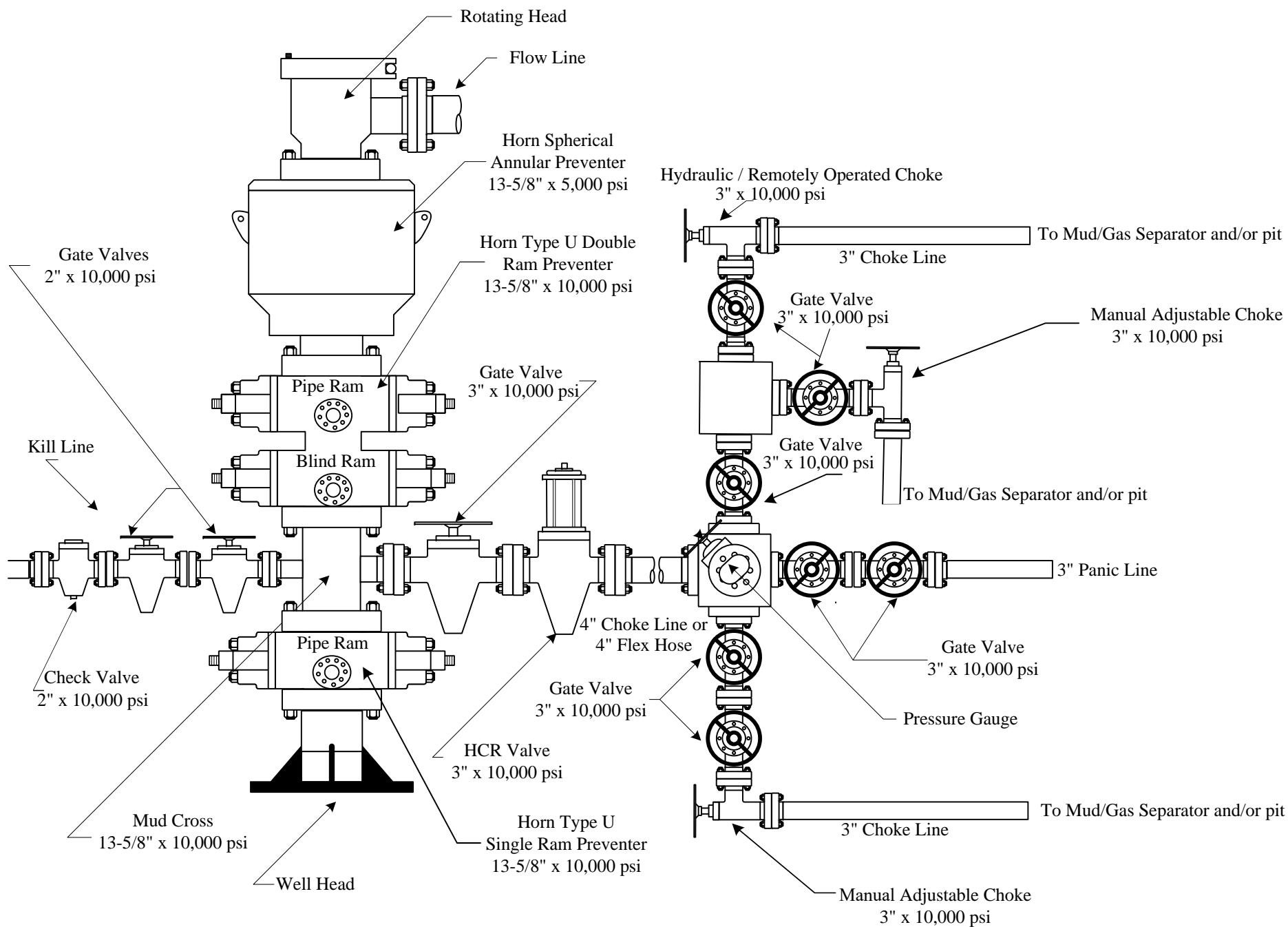

## **PECOS DISTRICT DRILLING CONDITIONS OF APPROVAL**

**All Previous COAs Still Apply. Variance request procedure is approved as written, please see below general conditions for variance.**

### **A. PRESSURE CONTROL**

**(Note: For a minimum 5M MASP or less (Utilizing a 10M BOPE system))**

#### **BOPE Break Testing Variance (Approved)**

- BOPE Break Testing is ONLY permitted for 5M psi MASP or less. **(Annular preventer must tested to 100% working pressure and BOPE shall be tested to full Rated Pressure)**
- While in transfer between wells, the BOPE shall be secured by the hydraulic carrier or cradle.
- Any well control event while drilling require notification to the BLM Petroleum Engineer **(575-706-2779)** prior to the commencement of any BOPE Break Testing operations.
- The BLM is to be contacted **(575-361-2822 Eddy County)** 4 hours prior to BOPE tests.
- As a minimum, a full BOPE test shall be performed at **21-day** intervals.
- In the event any repairs or replacement of the BOPE is required, the BOPE shall test as per **43 CFR part 3170 Subpart 3172**.
- If in the event break testing is not utilized, then a full BOPE test would be conducted.
- The BOPE testing shall be conducted while the rig is stationary.

#### **Intermediate Break Testing Section:**

- Variance only pertains to the intermediate hole-sections shallower than the deepest drilled intermediate on the well pad above 12,000 feet.
- A full BOPE test is required prior to drilling the first deep intermediate hole section. If any subsequent hole interval is deeper than the first, a full BOPE test will be required. (200' TVD tolerance between intermediate shoes is allowable).

#### **Offline BOPE Testing**

Operator has been **(Approved)** to test the BOPE offline.

The BOPE offline testing shall be stationary during pressure testing.

Online BOPE testing should commence within 72 hours of offline BOPE testing completion. Notify the BLM if interval exceeds 72 hours.

Notify the BLM 4hrs prior to offline BOPE testing at **Eddy County: 575-361-2822**.

## GENERAL REQUIREMENTS

The BLM is to be notified in advance for a representative to witness:

- a. Spudding well (minimum of 24 hours)
- b. Setting and/or Cementing of all casing strings (minimum of 4 hours)
- c. BOPE tests (minimum of 4 hours)

Eddy County

**EMAIL** or call the Carlsbad Field Office, 620 East Greene St., Carlsbad, NM 88220,

**BLM\_NM\_CFO\_DrillingNotifications@BLM.GOV**

(575) 361-2822

Lea County

Call the Hobbs Field Station, 414 West Taylor, Hobbs NM 88240,

(575) 689-5981

1. Unless the production casing has been run and cemented or the well has been properly plugged, the drilling rig shall not be removed from over the hole without prior approval.
  - a. In the event the operator has proposed to drill multiple wells utilizing a skid/walking rig. Operator shall secure the wellbore on the current well, after installing and testing the wellhead, by installing a blind flange of like pressure rating to the wellhead and a pressure gauge that can be monitored while drilling is performed on the other well(s).
  - b. When the operator proposes to set surface casing with Spudder Rig
    - Notify the BLM when moving in and removing the Spudder Rig.
    - Notify the BLM when moving in the 2<sup>nd</sup> Rig. Rig to be moved in within 90 days of notification that Spudder Rig has left the location.
    - BOP/BOPE test to be conducted per **43 CFR part 3170 Subpart 3172** as soon as 2nd Rig is rigged up on well.
2. Floor controls are required for 3M or Greater systems. These controls will be on the rig floor, unobstructed, readily accessible to the driller and will be operational at all times during drilling and/or completion activities. Rig floor is defined as the area immediately around the rotary table; the area immediately above the substructure on which the draw works are located, this does not include the dog house or stairway area.
3. The record of the drilling rate along with the GR/N well log run from TD to surface (horizontal well – vertical portion of hole) shall be submitted to the BLM office as well as all other logs run on the borehole 30 days from completion. If available, a

digital copy of the logs is to be submitted in addition to the paper copies. The Rustler top and top and bottom of Salt are to be recorded on the Completion Report.

A. CASING

1. Changes to the approved APD casing program need prior approval if the items substituted are of lesser grade or different casing size or are Non-API. The Operator can exchange the components of the proposal with that of superior strength (i.e. changing from J-55 to N-80, or from 36# to 40#). Changes to the approved cement program need prior approval if the altered cement plan has less volume or strength or if the changes are substantial (i.e. Multistage tool, ECP, etc.). The initial wellhead installed on the well will remain on the well with spools used as needed.
2. Wait on cement (WOC) for Potash Areas: After cementing but before commencing any tests, the casing string shall stand cemented under pressure until both of the following conditions have been met: 1) cement reaches a minimum compressive strength of 500 psi for all cement blends, 2) until cement has been in place at least 24 hours. WOC time will be recorded in the driller's log. The casing integrity test can be done (prior to the cement setting up) immediately after bumping the plug.
3. Wait on cement (WOC) for Water Basin: After cementing but before commencing any tests, the casing string shall stand cemented under pressure until both of the following conditions have been met: 1) cement reaches a minimum compressive strength of 500 psi at the shoe, 2) until cement has been in place at least 8 hours. WOC time will be recorded in the driller's log. See individual casing strings for details regarding lead cement slurry requirements. The casing integrity test can be done (prior to the cement setting up) immediately after bumping the plug.
4. Acceptable Method of Cement Verifications:
  - a. Observing cement circulated to surface.
  - b. Cement bond log (CBL).
  - c. Temperature log within 8-10 hours after completing the cement job.
  - d. Echometer (if a second-stage bradenhead squeeze is being used).
5. Provide compressive strengths including hours to reach required 500 pounds compressive strength prior to cementing each casing string. Have well specific cement details onsite prior to pumping the cement for each casing string.
6. No pea gravel permitted for remedial or fall back remedial without prior authorization from the BLM engineer.
7. On that portion of any well approved for a 5M BOPE system or greater, a pressure integrity test of each casing shoe shall be performed. Formation at the shoe shall be tested to a minimum of the mud weight equivalent anticipated to control the

formation pressure to the next casing depth or at total depth of the well. This test shall be performed before drilling more than 20 feet of new hole.

8. If hardband drill pipe is rotated inside casing, returns will be monitored for metal. If metal is found in samples, drill pipe will be pulled and rubber protectors which have a larger diameter than the tool joints of the drill pipe will be installed prior to continuing drilling operations.
9. Whenever a casing string is cemented in the R-111-P potash area, the NMOCD requirements shall be followed.

#### B. PRESSURE CONTROL

1. All blowout preventer (BOP) and related equipment (BOPE) shall comply with well control requirements as described in **43 CFR part 3170 Subpart 3172** and **API STD 53 Sec. 5.3**.
2. If a variance is approved for a flexible hose to be installed from the BOP to the choke manifold, the following requirements apply: The flex line must meet the requirements of API 16C. Check condition of flexible line from BOP to choke manifold, replace if exterior is damaged or if line fails test. Line to be as straight as possible with no hard bends and is to be anchored according to Manufacturer's requirements. The flexible hose can be exchanged with a hose of equal size and equal or greater pressure rating. Anchor requirements, specification sheet and hydrostatic pressure test certification matching the hose in service, to be onsite for review. These documents shall be posted in the company man's trailer and on the rig floor.
3. 5M or higher system requires an HCR valve, remote kill line and annular to match. The remote kill line is to be installed prior to testing the system and tested to stack pressure.
4. If the operator has proposed a multi-bowl wellhead assembly in the APD. The following requirements must be met:
  - a. Wellhead shall be installed by manufacturer's representatives, submit documentation with subsequent sundry.
  - b. If the welding is performed by a third party, the manufacturer's representative shall monitor the temperature to verify that it does not exceed the maximum temperature of the seal.
  - c. Manufacturer representative shall install the test plug for the initial BOP test.
  - d. Whenever any seal subject to test pressure is broken, all the tests in 43 CFR 3172.6(b)(9) must be followed.

- e. If the cement does not circulate and one inch operations would have been possible with a standard wellhead, the well head shall be cut off, cementing operations performed and another wellhead installed.
5. The appropriate BLM office shall be notified a minimum of 4 hours in advance for a representative to witness the tests.
- a. In a water basin, for all casing strings utilizing slips, these are to be set as soon as the crew and rig are ready and any fallback cement remediation has been done. The casing cut-off and BOP installation can be initiated four hours after installing the slips, which will be approximately six hours after bumping the plug. For those casing strings not using slips, the minimum wait time before cut-off is eight hours after bumping the plug. BOP/BOPE testing can begin after cut-off or once cement reaches 500 psi compressive strength (including lead cement), whichever is greater. However, if the float does not hold, cut-off cannot be initiated until cement reaches 500 psi compressive strength (including lead when specified).
  - b. In potash areas, for all casing strings utilizing slips, these are to be set as soon as the crew and rig are ready and any fallback cement remediation has been done. For all casing strings, casing cut-off and BOP installation can be initiated at twelve hours after bumping the cement plug. The BOPE test can be initiated after bumping the cement plug with the casing valve open. (only applies to single stage cement jobs, prior to the cement setting up.)
  - c. The tests shall be done by an independent service company utilizing a test plug not a cup or J-packer and can be initiated immediately with the casing valve open. The operator also has the option of utilizing an independent tester to test without a plug (i.e. against the casing) pursuant to **43 CFR part 3170 Subpart 3172** with the pressure not to exceed 70% of the burst rating for the casing. Any test against the casing must meet the WOC time for water basin (8 hours) or potash (24 hours) or 500 pounds compressive strength, whichever is greater, prior to initiating the test (see casing segment as lead cement may be critical item).
  - d. The test shall be run on a 5000 psi chart for a 2-3M BOP/BOP, on a 10000 psi chart for a 5M BOP/BOPE and on a 15000 psi chart for a 10M BOP/BOPE. If a linear chart is used, it shall be a one hour chart. A circular chart shall have a maximum 2 hour clock. If a twelve hour or twenty-four hour chart is used, tester shall make a notation that it is run with a two hour clock.
  - e. The results of the test shall be reported to the appropriate BLM office.
  - f. All tests are required to be recorded on a calibrated test chart. A copy of the BOP/BOPE test chart and a copy of independent service company test will be submitted to the appropriate BLM office.

- g. The BOP/BOPE test shall include a low pressure test from 250 to 300 psi. The test will be held for a minimum of 10 minutes if test is done with a test plug and 30 minutes without a test plug. This test shall be performed prior to the test at full stack pressure.
- h. BOP/BOPE must be tested by an independent service company within 500 feet of the top of the Wolfcamp formation if the time between the setting of the intermediate casing and reaching this depth exceeds 20 days. This test does not exclude the test prior to drilling out the casing shoe as per **43 CFR part 3170 Subpart 3172**.

C. DRILLING MUD

Mud system monitoring equipment, with derrick floor indicators and visual and audio alarms, shall be operating before drilling into the Wolfcamp formation, and shall be used until production casing is run and cemented.

D. WASTE MATERIAL AND FLUIDS

All waste (i.e. drilling fluids, trash, salts, chemicals, sewage, gray water, etc.) created as a result of drilling operations and completion operations shall be safely contained and disposed of properly at a waste disposal facility. No waste material or fluid shall be disposed of on the well location or surrounding area.

Porto-johns and trash containers will be on-location during fracturing operations or any other crew-intensive operations.

Sante Fe Main Office  
Phone: (505) 476-3441

General Information  
Phone: (505) 629-6116

Online Phone Directory  
<https://www.emnrd.nm.gov/ocd/contact-us>

**State of New Mexico**  
**Energy, Minerals and Natural Resources**  
**Oil Conservation Division**  
**1220 S. St Francis Dr.**  
**Santa Fe, NM 87505**

CONDITIONS

Action 571365

**CONDITIONS**

Operator: CIMAREX ENERGY CO. OF COLORADO 6001 Deauville Blvd Midland, TX 79706	OGRID: 162683
	Action Number: 571365
	Action Type: [C-103] NOI Change of Plans (C-103A)

**CONDITIONS**

Created By	Condition	Condition Date
ward.rikala	Any previous COA's not addressed within the updated COA's still apply.	4/8/2026