

Form 3160-3
(October 2024)

FORM APPROVED
OMB No. 1004-0137
Expires: October 31, 2027

UNITED STATES
DEPARTMENT OF THE INTERIOR
BUREAU OF LAND MANAGEMENT
APPLICATION FOR PERMIT TO DRILL OR REENTER

1a. Type of work: <input checked="" type="checkbox"/> DRILL <input type="checkbox"/> REENTER 1b. Type of Well: <input type="checkbox"/> Oil Well <input checked="" type="checkbox"/> Gas Well <input type="checkbox"/> Other 1c. Type of Completion: <input type="checkbox"/> Hydraulic Fracturing <input checked="" type="checkbox"/> Single Zone <input type="checkbox"/> Multiple Zone		5. Lease Serial No. NMSF078768 6. If Indian, Allottee or Tribe Name 7. If Unit or CA Agreement, Name and No. NMNM078407E/ROSA UNIT 8. Lease Name and Well No. ROSA UNIT 808H 9. API Well No. 30-039-31515
2. Name of Operator LOGOS OPERATING LLC		10. Field and Pool, or Exploratory BASIN MANCOS/BASIN MANCOS 11. Sec., T. R. M. or Blk. and Survey or Area SEC 24/T31N/R5W/NMP
3a. Address 2010 AFTON PLACE, FARMINGTON, NM 87401	3b. Phone No. (include area code) (505) 278-8720	
4. Location of Well (Report location clearly and in accordance with any State requirements. *) At surface NESW / 1826 FSL / 1754 FWL / LAT 36.882853 / LONG -107.31659 At proposed prod. zone SESE / 900 FSL / 32 FEL / LAT 36.880314 / LONG -107.269414		12. County or Parish RIO ARRIBA 13. State NM
14. Distance in miles and direction from nearest town or post office*		
15. Distance from proposed* location to nearest property or lease line, ft. (Also to nearest drig. unit line, if any) 32 feet	16. No of acres in lease 946.71	17. Spacing Unit dedicated to this well FED: NMB001820
18. Distance from proposed location* to nearest well, drilling, completed, applied for, on this lease, ft. 25 feet	19. Proposed Depth 7243 feet / 20750 feet	20. BLM/BIA Bond No. in file FED: NMB001820
21. Elevations (Show whether DF, KDB, RT, GL, etc.) 6593 feet	22. Approximate date work will start* 12/01/2025	23. Estimated duration 45 days
24. Attachments		

The following, completed in accordance with the requirements of Onshore Oil and Gas Order No. 1, and the Hydraulic Fracturing rule per 43 CFR 3162.3-3 (as applicable)

- | | |
|---|---|
| 1. Well plat certified by a registered surveyor.
2. A Drilling Plan.
3. A Surface Use Plan (if the location is on National Forest System Lands, the SUPO must be filed with the appropriate Forest Service Office). | 4. Bond to cover the operations unless covered by an existing bond on file (see Item 20 above).
5. Operator certification.
6. Such other site specific information and/or plans as may be requested by the BLM. |
|---|---|

25. Signature (Electronic Submission)	Name (Printed/Typed) ETTA TRUJILLO / Ph: (505) 324-4145	Date 11/21/2025
Title Regulatory Specialist		
Approved by (Signature) (Electronic Submission)	Name (Printed/Typed) DAVE J MANKIEWICZ / Ph: (505) 564-7761	Date 03/11/2026
Title AFM-Minerals Office Farmington Field Office		

Application approval does not warrant or certify that the applicant holds legal or equitable title to those rights in the subject lease which would entitle the applicant to conduct operations thereon.
Conditions of approval, if any, are attached.

Title 18 U.S.C. Section 1001 and Title 43 U.S.C. Section 1212, make it a crime for any person knowingly and willfully to make to any department or agency of the United States any false, fictitious or fraudulent statements or representations as to any matter within its jurisdiction.



(Continued on page 2)

*(Instructions on page 2)

INSTRUCTIONS

GENERAL: This form is designed for submitting proposals to perform certain well operations, as indicated on Federal and Indian lands and leases for action by appropriate Federal agencies, pursuant to applicable Federal laws and regulations. Any necessary special instructions concerning the use of this form and the number of copies to be submitted, particularly with regard to local, area, or regional procedures and practices, either are shown below or will be issued by, or may be obtained from local Federal offices.

ITEM I: If the proposal is to redrill to the same reservoir at a different subsurface location or to a new reservoir, use this form with appropriate notations. Consult applicable Federal regulations concerning subsequent work proposals or reports on the well.

ITEM 4: Locations on Federal or Indian land should be described in accordance with Federal requirements. Consult local Federal offices for specific instructions.

ITEM 14: Needed only when location of well cannot readily be found by road from the land or lease description. A plat, or plats, separate or on the reverse side, showing the roads to, and the surveyed location of, the well, and any other required information, should be furnished when required by Federal agency offices.

ITEMS 15 AND 18: If well is to be, or has been directionally drilled, give distances for subsurface location of hole in any present or objective productive zone.

ITEM 22: Consult applicable Federal regulations, or appropriate officials, concerning approval of the proposal before operations are started.

ITEM 24: If the proposal will involve hydraulic fracturing operations, you must comply with 43 CFR 3162.3-3, including providing information about the protection of usable water. Operators should provide the best available information about all formations containing water and their depths. This information could include data and interpretation of resistivity logs run on nearby wells. Information may also be obtained from state or tribal regulatory agencies and from local BLM offices.

NOTICES

The Privacy Act of 1974 and regulation in 43 CFR 2.48(d) provide that you be furnished the following information in connection with information required by this application.

AUTHORITY: 30 U.S.C. 181 et seq., 25 U.S.C. 396; 43 CFR 3160

PRINCIPAL PURPOSES: The information will be used to: (1) process and evaluate your application for a permit to drill a new oil, gas, or service well or to reenter a plugged and abandoned well; and (2) document, for administrative use, information for the management, disposal and use of National Resource Lands and resources including (a) analyzing your proposal to discover and extract the Federal or Indian resources encountered; (b) reviewing procedures and equipment and the projected impact on the land involved; and (c) evaluating the effects of the proposed operation on the surface and subsurface water and other environmental impacts.

ROUTINE USE: Information from the record and/or the record will be transferred to appropriate Federal, State, and local or foreign agencies, when relevant to civil, criminal or regulatory investigations or prosecution, in connection with congressional inquiries and for regulatory responsibilities.

EFFECT OF NOT PROVIDING INFORMATION: Filing of this application and disclosure of the information is mandatory only if you elect to initiate a drilling or reentry operation on an oil and gas lease.

The Paperwork Reduction Act of 1995 requires us to inform you that:

The BLM connects this information to a new evaluation of the technical, safety, and environmental factors involved with drilling for oil and/or gas on Federal and Indian oil and gas leases. This information will be used to analyze and approve applications. Response to this request is mandatory only if the operator elects to initiate drilling or reentry operations on an oil and gas lease. The BLM would like you to know that you do not have to respond to this or any other Federal agency-sponsored information collection unless it displays a currently valid OMB control number.

BURDEN HOURS STATEMENT: Public reporting burden for this form is estimated to average 8 hours per response, including the time for reviewing instructions, gathering and maintaining data, and completing and reviewing the form. Direct comments regarding the burden estimate or any other aspect of this form to U.S. Department of the Interior, Bureau of Land Management (1004-0137), Bureau Information Connection Clearance Officer (WO-630), 1849 C Street, N.W., Mail Stop 401 LS, Washington, D.C. 20240.

Additional Operator Remarks

Location of Well

0. SHL: NESW / 1826 FSL / 1754 FWL / TWSP: 31N / RANGE: 5W / SECTION: 24 / LAT: 36.882853 / LONG: -107.31659 (TVD: 0 feet, MD: 0 feet)

PPP: SWSW / 0 FSL / 0 FWL / TWSP: 31N / RANGE: 4W / SECTION: 20 / LAT: 36.880518 / LONG: -107.314204 (TVD: 0 feet, MD: 0 feet)

PPP: LOT 4 / 0 FSL / 0 FWL / TWSP: 31N / RANGE: 4W / SECTION: 19 / LAT: 36.880518 / LONG: -107.314204 (TVD: 0 feet, MD: 0 feet)

PPP: SESW / 975 FSL / 2451 FWL / TWSP: 31N / RANGE: 5W / SECTION: 24 / LAT: 36.880518 / LONG: -107.314204 (TVD: 7233 feet, MD: 7650 feet)

BHL: SESE / 900 FSL / 32 FEL / TWSP: 31N / RANGE: 4W / SECTION: 20 / LAT: 36.880314 / LONG: -107.269414 (TVD: 7243 feet, MD: 20750 feet)

BLM Point of Contact

Name: CHRISTOPHER P WENMAN

Title: Natural Resource Specialist

Phone: (505) 564-7727

Email: cwenman@blm.gov

CONFIDENTIAL



CARSON NATIONAL FOREST JICARILLA RANGER DISTRICT

CONDITIONS OF APPROVAL

- Application for Permit to Drill (APD) APD ID: 10400108419
- Sundry Notice

Date:	03/03/2026
Operator:	LOGOS Operating, LLC
Well Name:	Rosa Unit #800H
API Number:	

Legal Description:

Surface Location:

Section: **24** Township: **31N** Range: **5W**, NMPPM.
 Footages: **1903 FSL, 1690 FWL**

Bottom Hole Location (If different):

Section: **00** Township: **00N** Range: **0W**, NMPPM.
 Footages: **0000 FSL, 0000 FWL**

The following conditions of approval (COAs) will apply to this location and all associated activities and facilities on National Forest System (NFS) lands. COAs remain in effect until final abandonment and reclamation is accepted by the Forest Service Authorized Officer.

SITE SPECIFIC CONDITIONS OF APPROVAL

A. Pre-Construction

- The operator or their representative will contact and schedule an on-site pre-construction meeting with the Authorized Officer, (505) 632-2956. At the time of the pre-construction meeting all access/pipeline route stakes, location stakes, well bore stake, and any archeological protective barrier(s), if applicable, will be properly located and easily identifiable. It is recommended that, at a minimum, the operator representative and the construction contractor attend the pre-construction meeting.
- The operator will ensure that a complete copy of the APD, including the surface use plan of operations (SUPO) with COAs, is always readily available to all persons at the project area.

B. Cultural Resources

- No archeological monitoring or fencing is required; refer to the attached Record of Review (ROR) in the event of an inadvertent discovery.
- Archeological stipulations apply. Follow the protective measures provided in the attached ROR. Disclosure of site location information to unauthorized personnel is prohibited under 36 CFR 296.18.

C. Wildlife Resources

- Migratory Bird:** If vegetation removal, ground disturbing activities, or construction is scheduled to occur prior to July 31st a nesting bird survey is required. Results of the survey may result in additional mitigation measures.
- Mexican Spotted Owl (MSO) Protocol surveys are required.
- Northern Goshawk Protocol survey is required.
- Other required survey(s):

D. Gates

- A locked gate will be required in a location on the access road to this well as determined by the Authorized Officer. Refer to the Roads/Access section for gate design and construction specifications.

- The existing gate on Forest Road will be in functioning condition when drilling and completion are done. Refer to the Roads/Access section for existing gate requirements. The operator will be responsible for gate maintenance for the life of the well.

E. Required Seed Mixture

Seed Mixture: See attached BLM-FFO pinyon-juniper community guidelines for seed mixture and specifications. Mulching and the sterile cover crop option is required. These requirements apply to pad and pipeline seeding.

F. Other

1. The operator will ensure water runoff is adequately routed around the location during drilling and completion activities. Prior to interim reclamation a field visit, with the Authorized Officer, will be required to determine a long-term drainage strategy, road alignment, and facility layout.
2. Excess wood will be decked on the pad, in an area safe for public wood cutters. Any wood remaining at interim reclamation will be used for erosion control.
3. The Authorized Officer must approve in advance the use of any compressor. Mitigation measures may be required for sound management and resource protection.
4. Ground disturbance from the Forest Road 309 intersection to #11, along the staking line, is limited to the existing road.
5. Corner #2-#3 will be rounded to the corner stakes, with no construction zone, to prevent cuts from exceeding 15 feet.
6. The operator will re-locate the gate on the 309F road to the access from the 309 road to Pad 43, in a location approved by the Authorized Officer. The operator will place large rocks or stumps, from the project area, on both sides of the gate to prevent unauthorized motor vehicle use around the gate.
7. The operator will place large rocks, stumps, and logs, from the project area, from corner #6 to corner #7 to help stabilize the fill slope.
8. See attached location diagram for approved project area.

GENERAL CONDITIONS OF APPROVAL

A. Construction, Drilling, and Interim Reclamation

1. Location Development

- A. No ground disturbing activities or vehicle/equipment use is authorized outside of the approved project area. The Authorized Officer must be contacted prior to conducting any ground disturbing activities.
- B. The operator will follow all the design features, best management practices, and mitigation measures as contained in the National Environmental Policy Act project record and decision for this project.
- C. Road building, location construction, drilling, and completion activities are permitted from April 1st through October 31st of each year. Approval of activities between November 1st and March 31st may be granted on a case-by-case basis by the Authorized Officer.
- D. Unless otherwise specified all trees will be utilized for erosion control where possible. Trees are to be cut into 8-10 foot sections and stockpiled until reclamation. Upon reclamation they are to be distributed around the location or access road in such a way as to help reduce erosion or create wildlife habitat but not create an unnecessary fire hazard. Small diameter trees and slash may be mulched or chipped and stripped with the topsoil. Slash may be chipped, mulched, or stockpiled for placement on seeded areas. Excess wood will be purchased by the operator and removed under commercial wood permit or left stockpiled in an area approved by the Authorized Officer and accessible to the public by motor vehicle. Trees left for reclamation, in areas behind locked gates, will be protected from theft by means such as fencing or signage. For project areas that are accessible by motor vehicle to the public the Authorized Officer may require the operator to temporarily stockpile trees behind a locked gate, in an area approved by the Authorized Officer, to ensure an adequate amount remains for reclamation.
- E. No burning of trees or slash is authorized.
- F. Company signs are allowed on NFS lands during construction, drilling, completion, and work-over operations. Signs are not to be attached to any trees and all signs are to be immediately removed upon project completion.

2. Slope Ratios

- A. The final cut slope will not exceed a 4:1 ratio. The final fill slope will not exceed a 4:1 ratio. To obtain this ratio, pits and slopes will be back sloped into the pad upon completion of drilling and prior to setting production equipment. Construction slopes can be much steeper during drilling but will be contoured to the above final slopes upon pit reclamation. Any final slope that exceeds a 4:1 ratio must be approved by the Authorized Officer. Steeper slopes may require additional mitigation measures, such as seed matting, to ensure soil stabilization and reclamation. Slopes will be contour ripped, pocked, or water barred to prevent erosion on the location and erosion control will be designed in a manner that excessive erosion does not occur off-site.
- B. The pad will be designed, constructed, and maintained in such a manner that water does not pool in the working area of the location. Location drainage must be designed and maintained in such a manner that rilling, gulying, or excessive erosion does not take place. Mitigation measures such as road surfacing or re-contouring of the location may be required if adequate location drainage is not achieved.

3. Topsoil Recovery

- A. Topsoil will be stripped from the project area (minimum 6 inches deep, or all that is available if less than 6 inches), including access road, and be deposited in storage piles apart from other excavated material. It will be kept separate and protected, either in piles or windrowed. Upon reclamation the stored topsoil will be evenly spread over all areas outside the working area of the pad. Along access roads it is to be distributed over final cut and fill slopes. Only subsurface soil and material shall be utilized in the contouring of the cut and fill slopes. Under no circumstances shall topsoil be utilized as substrate material for contouring of cut and fill slopes.
- B. If the ground is saturated and topsoil recovery is not possible all construction is to cease until conditions dry to the point that topsoil can be stripped and recovered. Any snow is to be stripped and stored separately from the topsoil.
- C. When work-over activities or other surface disturbances are required during production, topsoil that was previously salvaged and redistributed must be stripped off and salvaged. The topsoil must be kept separate and protected from other spoil or equipment activities. After the work-over or other operation that required the surface disturbance is completed, the stripped topsoil must be evenly spread over the exposed subsoil and the disturbed area will be promptly reclaimed following the reclamation section requirements.

4. Reserve Pit

- A. The reserve pit will be approved, constructed, operated, maintained, and closed pursuant to all applicable federal, state, and local laws and regulations. The pit and closure plan must be approved, by the Authorized Officer, in advance.
- B. The operator will ensure the reserve pit is adequately fenced to prevent unauthorized access and take all reasonable measures to protect public safety, wildlife, and livestock. The operator will maintain the fence in good repair. Minimum fence standards include a four-foot woven wire fence with a top rail or barbed top wire and H-braced corners.
- C. Unless otherwise approved by the Authorized Officer, the reserve pit is to be closed prior to November 1st.

5. Equipment and Vehicles

- A. All vehicles and equipment will be kept free of leaks. Any leaks/spills will be appropriately contained, and the vehicle/equipment repaired or removed from the construction, production, or lease area in such a way as to prevent further spills. Any contaminated soil will be removed and disposed of properly. Fluids from routine vehicle/equipment maintenance will be removed and disposed of properly.
- B. All vehicles and equipment should be properly cleaned/inspected prior to entering NFS lands to prevent spills/leaks and/or weed contamination.
- C. Vehicle and equipment use is only authorized in the approved project area and on designated roads.
- D. Vehicles and all equipment associated with lease operations must be driven and operated in a safe and responsible manner.
- E. An approved muffler or spark arrester will be maintained on the exhausts of all vehicles, equipment, or other internal combustion engines.

6. Well Sites Constructed and not Drilled

If this well is constructed and not drilled the location and access road must be reclaimed, per the standards outlined in the Final Reclamation and Abandonment section at the time of APD expiration. If the well is not drilled before November 1st of the year that initial ground disturbance takes place the Authorized Officer may require interim mitigation measures such as seeding, the installation of water bars, or other site-specific measures to ensure temporary soil stability and prevent erosion. Unless otherwise approved any archeological protective fencing must be removed and then re-established prior to commencement of activities.

B. Production/Facilities

1. Production Facilities

Design and layout of facilities will be deferred until an onsite with the Authorized Officer is conducted to determine the best layout. The operator or their representative will contact the Authorized Officer to schedule a facility layout onsite. No facilities will be installed without prior approval by the Authorized Officer. Once a design and layout plan is approved by the Authorized Officer any modifications must be approved in advance by the Authorized Officer.

2. General facility requirements

- A. Production facilities (including berms) will be placed on cut a minimum of 10 feet from the toe of the cut. If pad location does not allow for facilities to be placed on cut, facilities may be placed, with Authorized Officer approval, on fill. All facilities including berms will be located a minimum of 10 feet from the top of the fill.
- B. Production facilities, including any facilities associated with pipeline operations, will be placed on location as not to interfere with reclaiming the cut and fill slopes to their proper ratio. If equipment is found to interfere with the proper reclamation of the slope, the operator will be required to move the equipment so proper re-contouring can occur.
- C. All open top permanent production or storage tanks, regardless of diameter, made of fiberglass, steel, or other material used for containment of oil, condensate, produced water, or other production waste will be screened, netted, or otherwise covered to protect migratory birds and other wildlife from access. Exhaust vents/stacks will have devices/screens installed to prevent bird/wildlife access.
- D. No weeds or vegetation are allowed on or within secondary containment berms/structures.
- E. A "residential style" muffler is required on production engines to reduce noise levels. In noise sensitive areas (NSA) a "hospital grade" muffler is required. Within a noise sensitive area noise levels will comply with BLM guidelines and standards for NSA's.
- F. Compressor engines 300 horsepower or less used during well production must be rated by the manufacturer as emitting NOx at 2 grams per horsepower hour or less to comply with the New Mexico Environmental Department, Air Quality Bureau's guidance. Compressor units not equipped with a drip pan for containment of fluids will be placed in a containment berm. The area within the containment berm will be lined with an impervious material at least 8 mils thick. The berm will be a minimum of 12 inches tall and graveled to prevent erosion. The compressor will be painted to match the well facilities. When compressor units are washed, or any equipment associated with the location, the fluids (i.e., scrubber cleaners) will be properly disposed of to avoid ground contamination or hazard to livestock or wildlife. Fencing and/or exclusion devices may

be required to protect birds, wildlife, or livestock.

- G. All well and facility locations will be properly identified and signed per applicable laws and regulations. Production tanks and all bulk storage tanks must be labeled to identify contents. All storage tanks/vessels must be labeled/placarded in accordance with all applicable laws and regulations.
- H. All above ground surface structures and equipment will be painted a non-glare color as follows: Green, Federal Standard 595a-34127 (Juniper Green). The exception being where applicable laws and/or regulations require other colors or markings. The operator may request different colors or markings if operator safety policies dictate. All facilities must be painted within three months of installation. Periodic repainting of facilities will be required to keep all facilities maintained in an acceptable condition.
- I. All above ground appurtenances and facilities must be approved in advance by the Authorized Officer. The operator must notify the Authorized Officer prior to removing or terminating any pipeline, equipment, storage vessel/tank, or facility. Site mitigation may be required upon facility/equipment removal.
- J. Any facility, tank, container, vessel, or equipment not in use for thirty days must be removed from National Forest System (NFS) lands. Authorization to keep unused facilities or equipment on NFS lands beyond thirty days must be obtained from the Authorized Officer. Site mitigation may be required upon facility/equipment removal.

3. Secondary Containment

- A. Unless otherwise specified or approved all storage facilities (including produced water tanks) must be contained in a secondary spill containment structure. All containment berms, containment walls, drip pans, or equivalent protection structures are to be constructed and maintained around all storage facilities, including tank batteries. The containment structure must have sufficient volume to contain, at a minimum, the content of the largest storage tank within the facility/battery and sufficient freeboard to contain precipitation, unless more stringent protective requirements are deemed necessary by the Authorized Officer. All chemical and equipment oil/fluid/fuel storage vessels, whether the vessels are permanent or temporary, must be fully contained within a secondary spill containment structure. Secondary containment capacity will be calculated at the lowest point on the structure.
- B. All well facilities, tanks, and storage facilities/vessels will prevent birds, wildlife (including wild horses) and livestock from having access to all produced fluids and any other onsite fluids or solids that could be harmful. This may include fencing all production pits/tanks (48-inch height, braced corners, top rail or barbed top wire, and 4 strand wire or woven wire fence.), compressors, tank batteries, and containment troughs. Screens, covered troughs, and drip pan covers may be used where suitable and constructed in such a way that wildlife/birds cannot access the contents at its highest level. Self-closing gates or walk-overs are required with any fencing and over

containment berms/structures. All gates need to be kept closed and fences should not be affected by flow lines. Fences should be located and maintained to keep all animals a safe distance. All structures, fences, or barriers must be approved, by the Authorized Officer, prior to installation.

- C. Gravel or another sufficiently impervious material will be placed on berms to prevent erosion. The berm will be maintained so that it does not erode, ensures adequate containment, and prevents livestock or wildlife from entering the containment structure.
- D. Load-out lines must terminate within the containment berm unless otherwise approved by the Authorized Officer.
- E. For crude oil, condensate, or produced water lines, either a trucker supplied mobile or permanent catch basin will be installed at the point of hook-up. Unless otherwise approved in advance, by the Authorized Officer, no pipes, cables, or gas lines are to be routed through the berm itself.

4. Roads/Access

- A. The operator will be a member, in good standing, of the Carson Forest Road Maintenance Committee (Jicarilla Road Committee), unless otherwise approved by the Authorized Officer. Except for roads designated and accepted for maintenance as part of the Jicarilla Road Committee, the operator is responsible for maintenance of all roads that are designated and authorized for use. The operator is responsible for all road maintenance, if the operator is the only authorized user, or in part if multiple users are authorized.
- B. All construction activities, vehicle, and equipment use is to cease if the road surface or ground is saturated to the point that rutting greater than 6 inches occurs. The operator is responsible for any road damage caused by wet weather operation. No mud plowing or the use of equipment to drag/assist other vehicles/equipment will be allowed during wet, snow, or muddy road conditions.
- C. **New Gate:** The gate will be constructed of 2-inch pipe in a design that will prohibit unauthorized motorized vehicles from driving under or around it. The gate will be painted green, Federal Standard 595a-34127, and incorporate road closed signs and reflectorized barricade signs that meet Authorized Officer standards. These signs must be installed at the time of gate construction to ensure public safety. A lock box containing enough holes for all authorized user locks plus one hole for a FS lock will be constructed. Wing fencing may be needed on either or both sides of the fence to ensure unauthorized motorized vehicles cannot travel around the gate. Wing fencing must stay within the approved project area. The gate must be constructed before the first big game hunt and then left locked or secured with a gate guard to prevent unauthorized motor vehicle travel. The operator will have routine maintenance responsibility for this gate for the life of the well. The operator will ensure that the gate and any associated wing fencing is functional, all authorized users have access, and all required road closed, and reflective/safety signage is present.

- D. **Existing Gate:** The operator will have routine maintenance responsibility for this gate for the life of the well. This operator will ensure that the gate and any associated wing fencing is functional, all authorized users have access, and all required road closed, and reflective/safety signage is present.
- E. All NFS roads damaged by construction, production, and/or lease activities will be restored to a functional and acceptable condition. This includes, but is not limited to restoring original ditch lines, replacing, or repairing any damaged culverts, re-establishing road surfacing where surfacing was lost or contaminated, and restoring effective road drainage.
- F. Unless otherwise required or specified, all roads on NFS lands will be designed, constructed, and maintained to Gold Book Standards (United States Department of the Interior and United States Department of Agriculture. 2006. Surface Operating Standards and Guidelines for Oil and Gas Exploration and Development. BLM/WO/ST-06/021+3071. Bureau of Land Management. Denver, Colorado. 84pp. and any revisions thereto) for FS local roads. The driving surface on all access roads will be limited to 14 feet in width, and total disturbance will be limited to 24 feet not including cuts and fills or turnouts. Any access road constructed will be crowned and ditched, in-sloped, or out-sloped where appropriate. This will require installation of culverts and/or armored water bars per Gold Book standards. Additional cross drainage may be required depending upon site specific circumstances. Culvert size will be a minimum of 18", larger culverts will be required where appropriate. Riprapping, velocity breaks or other drainage/erosion control measures may be required. Adequate and effective drainage will be constructed and maintained in good working order. Topsoil will be stockpiled and redistributed for reclamation on cut and fill slopes and the cut and fill slopes will be re-vegetated to the same standard as the well pad. All maintenance activities must be approved in advance by the Authorized Officer.
- G. If, upon abandonment of the well location, the retention of the access road is not considered necessary by the Authorized Officer, it will be re-contoured to as near natural as possible. The access road and well location will be closed to vehicular travel. Re-vegetation of the affected area will be required. Alternatively, the Authorized Officer may request the road be lightly ripped to eliminate compaction. The road will be water barred, pocked, or contoured ripped where necessary to ensure soil stability and prevent erosion. Construction of a barricade at the entrance to these areas may be required. Re-vegetation of the affected area will be required.
- H. If, upon abandonment of the well location, the retention of the access road is considered necessary by the Authorized Officer, then the gate, if any, will remain in place, and it is to be converted by the operator to a single lock locking system.
- I. No gravel or other related minerals from new or existing pits on NFS lands will be used in construction of roads, well sites, etc., without prior approval from the Authorized Officer.

- J. Water dips and culverts will be constructed and maintained in working condition on the access road to the well location. The Gold Book standard for maximum recommended culvert spacing will be utilized. Additional cross drainage may be required depending on site specific conditions.
- K. Produced water will either be piped or trucked for proper disposal. If trucked, operator will be responsible for any road damage or damage to cattleguards, fences, culverts, drainage structures, and road surface caused by water hauling. The time of day for water hauling may be limited.
- L. The operator will keep all road gates locked at all times. During activities that require heavy traffic volume a gate may left open with a gate guard posted to regulate unauthorized motor vehicle traffic. Motorized vehicle travel on authorized use roads, behind gates, is prohibited except for authorized use by the operator and/or their representatives performing lease activities.
- M. The Authorized Officer may restrict vehicle access during wet weather periods to protect roads and resources. The operator is responsible for all road damage caused by wet weather operations. The operator is encouraged to upgrade and maintain roads to an all-weather standard.
- N. Any road/traffic signs must be approved by the Authorized Officer prior to installation and installed and maintained in accordance with the Manual on Uniform Traffic Control Devices. All signs will be installed on break-away signposts.

5. Gates/Cattleguards/Fences

- A. Fencing of individual facilities, such as the pump jack (including well head), treater, and tank battery with wildlife and livestock proof fencing may be required. The fence around any fluid storage facilities must be constructed on the outside perimeter of the berms to protect them from deterioration due to animals walking over them.
- B. All cattle guards must have wings installed on both sides to prevent livestock from stepping around the ends. The cattle guard design and installation must meet all Authorized Officer standards and specifications and a cattleguard warning sign may be required. A 12-foot gate must be installed between the cattle guard and brace assemblies on whichever side of the cattle guard is most convenient. If the gate is made of wire, it must have at least four horizontal strands of barbed wire, with at least four 3-inch diameter vertical wood stays evenly spaced. When the gate is closed the wires must be taut. The operator is responsible for the maintenance of the cattle guard for the life of the project.
- C. Prior to crossing any fence located on federal land, or any fence between Federal land and private land, the operator will contact the Authorized Officer. All cut fences are to be secured to braces prior to cutting. The operator is responsible for repairing any fence

damage resulting from their activities. All fences are to be constructed and maintained to Authorized Officer standards.

- D. Any cut fence openings will be protected as necessary during construction to prevent the escape of livestock. A temporary closure will be installed on all cut fences the same day the fence is cut.

6. Interim Reclamation Requirements

- A. The operator will contact the Authorized Officer and schedule an onsite reclamation meeting prior to any reclamation activities.
- B. The operator will conduct a condition survey of the authorized area. The survey will include monitoring for erosion, vegetation reclamation, noxious weeds, unnecessary or excessive environmental impacts, hazardous conditions, facility(s) condition, unauthorized motorized vehicle use, and compliance with the SUPO and COAs. The operator will provide the Authorized Officer a written condition survey report within three years of initial project area disturbance. Mitigation measures may be required for any identified issues. The Authorized Officer may require additional surveys.
- C. All areas of the well pad and access road not needed for production facilities will be re-contoured to blend as nearly as possible with the natural topography. All areas outside the anchor points, not directly adjacent to facilities, or on the designated vehicle route will be reclaimed. These areas will be topsoiled, mulched (certified weed free straw mulch crimped in at 2 tons per acre or excelsior mats or equivalent will be used), and seeded with the required seed mix. Slopes will be contour ripped, pocked, or water barred to prevent erosion on the location and designed in a manner that excessive erosion does not occur off-site. Cut and fill slopes will be top soiled and mulched, as specified above, and revegetated.
- D. Seeding will be completed prior to November 1st unless otherwise approved by the Authorized Officer.
- E. The interim reclamation standard requires all areas not approved for bare ground trim-out, to meet the following requirements:
 - 1. Maintain native vegetative cover equal to 70%, or more, of the adjacent undisturbed area. Where areas have been disturbed because of maintenance or construction this requirement must be met within three growing seasons. This vegetation standard must be met with native vegetation species. If an identified area does not meet the minimum standard or an area has been disturbed the Authorized Officer will provide the operator a seed mixture and seeding guidelines for the site specific vegetation community. The area will be seeded and re-seeded annually, if necessary, until the standard is achieved and maintained.

2. The soil has been stabilized and no excessive erosion exists.
 3. There are no New Mexico Noxious Weed List Class A or B species or USDA Federal Noxious Weed List species present. If any of these noxious weed species are identified, a treatment plan will be required. If New Mexico Noxious Weed List Class C or Watch List species are identified the Authorized Officer will determine if a treatment plan is required.
 4. There are no signs of unauthorized motor vehicle use.
 5. No garbage, litter, or waste is present.
- F. Seeding should be repeated annually after three growing seasons until reclamation meets the above standard and is accepted by the Authorized Officer. Where vegetation is re-disturbed after establishment it will be reseeded annually until vegetation is re-established.
- G. To maintain purity and quality, certified seed is required.
- H. The operator will provide verification of seed mixture and weed free mulch certification within 30 days of completion.
- I. The operator is required to re-seed any previously seeded areas that have been disturbed from any production, work-over, or maintenance related activities.
- J. The operator is responsible for successful reclamation regardless of weather or other factors.
- K. The well pad may require fencing to protect or promote reclamation efforts. If reclamation fails due to grazing pressure, the Authorized Officer may require fencing of the location until reclamation is determined to be successful. This will also require the installation of a gate and/or cattleguard at the location access. All fences must be built and maintained to Authorized Officer standards.

7. Noxious Weed Control

- A. The operator will survey the authorized area for the presence of noxious weeds prior to initial ground disturbing activities. The operator will perform another survey within three years of initial project area development. The operator will submit the survey findings to the Authorized Officer within thirty days of the survey. If New Mexico Noxious Weed List Class A or B species or USDA Federal Noxious Weed List species are present a treatment plan will be required. If New Mexico Noxious Weed List Class C or Watch List species are identified the Authorized Officer will determine if a treatment plan is required.

- B. A Pesticide Use Proposal (PUP) must be submitted to and approved by the Authorized Officer prior to application of pesticide. The Authorized Officer can aid in the development of the PUP.
- C. All vehicles and equipment should be inspected for noxious weed contaminants and cleaned prior to entering NFS lands. This is especially important on vehicles from out of state or if coming from a weed-infested area.
- D. Fill dirt or gravel may be needed for excavation, road construction/repair, or for spill remediation. If fill dirt or gravel will be required, the source shall be noxious weed free and approved by the Authorized Officer.
- E. Only pesticides authorized for use on NFS lands will be used and applied by a licensed pesticide applicator. The use of pesticides will comply with all federal and state laws and will be used only in accordance with their registered use and limitations. The operator's licensed applicator will contact the Authorized Officer prior to using any pesticides.
- F. Noxious/invasive weed treatments must be reported to the Authorized Officer. A Pesticide Use Report (PUR) is required to report any mechanical, chemical, biological or cultural treatments used to eradicate, and/or control noxious or invasive species. Reporting will be required quarterly and annually or per request from the Authorized Officer.
- G. Bare ground vegetation trim-out: If bare ground vegetation treatment (trim-out) is desired around facility structures, the operator will submit a bare ground/trim-out design. The design will address the vegetation safety concerns of the operator, while minimizing impacts to reclamation efforts. The design must include what structures are to be treated and the buffer distances of trim-out. If pesticides are used for bare ground trim-out, the trim-out will not exceed three feet from the edge of any eligible permanent structure (e.g., doglegs, pig launchers, or tanks). Additional distance/areas may be requested but must be approved by the Authorized Officer. The additional information below must also be provided to the Authorized Officer:
 - 1. Pesticide use for trim out will require a PUP. A PUP is required prior to any treatment and must be approved by the Authorized Officer. Only pesticides authorized for use on NFS lands will be used and applied by a licensed pesticide applicator. The use of pesticides will comply with all federal and state laws and used only in accordance with their registered use and limitations. The operator's licensed applicator will contact the Authorized Officer prior to using these chemicals and provide PURs post treatment.
 - 2. A PUR or a Biological Use Report (BUR) is required to report any chemical, or biological treatments used to eradicate, or control vegetation on site. Reporting will be required quarterly and annually or per request from the Authorized Officer.

C. Natural/Cultural Resources

1. Wildlife Resources

- A. A survey for threatened, endangered or sensitive species will be conducted by the Authorized Officer or by an approved individual, prior to any construction activities. The Authorized Officer will indicate which species require surveys. Additional measures may be required to mitigate threatened, endangered, or sensitive species concerns.
- B. If, during operations the operator discovers any threatened, endangered, or sensitive species, all work in the vicinity of the discovery will be suspended and the discovery promptly reported to the Authorized Officer. The Authorized Officer will then specify what action is to be taken. Failure to notify the Authorized Officer about a discovery may result in civil or criminal penalties in accordance with the Endangered Species Act (as amended).
- C. The Authorized Officer will be notified within 24 hours of the discovery of any wildlife, bird, livestock, or wild horse that was trapped, injured, or died because of lease operations, activities, or facilities. Mitigation measures may be required to prevent further injury or fatality.
- D. If a bird nest containing eggs or young is encountered in the path of construction the operator will cease construction and consult with the Authorized Officer to determine appropriate actions.

2. Cultural and Paleontological Resources

- A. Archeologists employed by the operator must be permitted by the Forest Service to conduct an archeological survey on any NFS lands which may be disturbed.
- B. The operator and all subcontractors will abide by all the conditions contained in the Inventory Standards and Accounting Form (IS &A) and Archeological Record or Review (ROR) which is part of and attached to these COAs.
- C. If it is deemed necessary, the Authorized Officer may require the operator to perform recovery, excavation, or preservation of the site and its artifacts at the operator's expense. At the option of the Authorized Officer, this authorization may be terminated with no liability by the United States when such termination is deemed necessary to preserve or protect archeological, paleontological, or historic sites and artifacts.

D. Health and Safety

- A. Emergency situations do not require Authorized Officer notification prior to the operator acting. However, the Authorized Officer must be notified, within 24 hours of the incident, location, and actions that were taken. Mitigation measures may be required for any resource damage, road damage, etc. caused by these activities. Emergency situations include events, conditions, or situations that threaten human life/safety, and/or property, start fires, or cause or could potentially cause severe wildlife, resource, or environmental impacts. Example: Gas leaks, explosions, or chemical spills.
- B. The Authorized Officer must be notified as soon as possible of any condition that may result in a public health and/or safety concern, Forest Service road closure or blockage, or potential natural resource damage.
- C. The operator will maintain structures, facilities, improvements, and equipment in a safe and orderly manner and will take all appropriate and reasonable measures to protect the public, wildlife, and livestock from hazardous sites, equipment, materials, fire hazards, or unsafe conditions resulting from their operations.
- D. Any spill, release, or incident that requires reporting to any federal, state, or local government or regulatory agency will be reported to the Authorized Officer within the same time frame as required by that agency.
- E. The operator will immediately notify the Authorized Officer of all serious accidents which occur in connection with lease operations. Additional mitigations measures may be required to prevent further accidents.
- F. The operator will provide a chemically treated portable toilet unit when projects or activities require multiple workers for multiple days. Sewage will be properly disposed of in a manner and place specified by applicable laws and regulations. Burying of sewage from chemically treated portable toilets will not be allowed. When chemically treated portable toilets are not required the operator will ensure human waste is disposed of per the recommendations outlined in The “Leave No Trace Seven Principles” (© 1999 by the Leave No Trace Center for Outdoor Ethics: www.LNT.org). Human waste will not be disposed of in any identified natural or cultural area of resource concern.
- G. The operator will properly dispose of all trash, garbage, waste, or byproduct. A trash cage must be on location throughout all drilling and completion activities. Burying trash in the reserve pit will not be allowed. Burning of trash will not be allowed.
- H. Any waste, byproduct, chemical, or substance that spills or releases must be properly disposed of in accordance with applicable law, regulation, and/or condition of approval. Any contaminated soil must be excavated and removed for disposal or mitigated in accordance with applicable law, regulation, and/or condition of approval. No waste or byproduct will be discharged onto the ground or near a stream/erosional course or channel.

- I. If the well is cavitated any coal fines will be immediately washed off contaminated vegetation. Only fresh water may be used.
- J. Feeding or allowing wildlife or livestock access to food, garbage, refuse, waste, byproduct, and/or stored materials, etc. is prohibited.
- K. Work sites must be kept clear of litter and debris, and left hazard free at the end of every work shift. Any hazards must be clearly identified and isolated with reflective and protective barriers.
- L. Permanent protective barriers may be required around any facilities located near a roadway that could possibly become a public safety issue or hazard.
- M. The well location will be maintained in a clean, neat, and orderly manner. Trash, debris, unused machinery/equipment, excess equipment/parts, etc., will be removed immediately. No unused items will be stockpiled or stored on a well location or other NFS lands without prior approval of the Authorized Officer.
- N. The operator will abide by all applicable laws and regulations concerning hydrogen sulfide (H₂S). The operator will immediately notify the Authorized Officer if a location or facility poses an H₂S hazard or is required to be identified for H₂S hazards.
- O. The operator will abide by all Forest Service requirements during periods of fire restrictions. The Authorized Officer will make available information concerning current fire restriction levels and specific requirements. The operator is responsible for all damage and costs resulting from fires caused by their operations and activities. The operator will conduct all activities and maintain all facilities in a manner that reduces fire hazards and minimizes threats to operator facilities from potential wildfires.

E. Environmental Protection

- A. The operator will conduct all activities associated with this lease operation in a manner that will avoid or minimize the degradation of air, land, and water quality. In the construction, operation, maintenance, and termination of this lease operation, the operator will perform its activities in accordance with all applicable air and water quality standards, facility siting standards, and applicable laws and regulations.
- B. All applicable local, state, and federal laws and regulations concerning the transportation and disposal of produced water will be followed.

F. Surveys and Land Corners

- A. The operator will protect, in place, all public land survey monuments, private property corners, and Forest boundary markers. If any such land markers or monuments are destroyed the operator will see that they are reestablished or referenced in accordance with the procedures outlined in the "Manual of Instructions for the Survey of the Public

Land of the United States," the specification of the county surveyor, or the specification of the Authorized Officer.

- B. Further, the operator will ensure any official survey records affected by this activity will be amended as provided by law.
- C. Nothing in these stipulations will relieve the operator's liability for the willful destruction or modification of any Government survey marker as provided at 18 U.S.C. 1858.
- D. Avoid removal of any bearing trees. If any must be removed, they must be replaced according to Authorized Officer specifications.

G. Other Conditions of Approval

A. Explosives

Should the use of explosives be required during construction or lease activities, the operator will comply with all applicable local, state, and federal laws, regulations and requirements involving the storage, handling, preparation, and use of explosives. Prior to the use of any explosives, the operator will prepare an explosive use/blasting plan for Authorized Officer approval.

B. Vandalism

The operator will take reasonable measures to prevent and discourage vandalism or disorderly conduct, and when necessary, call in the appropriate law enforcement agency.

C. Subleasing Requirements

The operator will require all representatives, employees, sub-lessees, contractors, sub-contractors and their employees and representatives comply with the approved APD, including the SUPO and these COAs.

D. Improvements

1. Prior to crossing, using, or paralleling any improvement on NFS lands, the operator will contact the owner of the improvement to obtain mitigation measures to prevent damage to the improvements.
2. Any improvements, developments, facilities, activities, and/or infrastructure not specifically addressed in these COAs or the operator's approved SUPO are prohibited without Authorized Officer approval.

E. Changes in Operator, Company Name, or Address

The operator must notify the Authorized Officer in writing no later than 30 days after a

sale or transfer of facilities, a company name change, well name change, or a change in address.

F. Sanitation

The operation and maintenance of all sanitation, food service, and water-supply methods, systems, and facilities will comply with all applicable local, state, and federal laws and regulations.

H. Final Abandonment and Reclamation

A. Prior to abandonment, the operator will notify the Authorized Officer and provide an Abandonment Plan, for Authorized Officer approval, which specifies how the operator intends to reclaim the well pad and access road. The Abandonment Plan will address, but not be limited to:

1. Type and design of well bore marker.
2. Removal of all surface facilities.
3. Flushing/purging and capping/sealing pipelines if applicable.
4. Protecting/salvaging topsoil during location/access re-contouring.
5. Re-contouring of the pad and access road to natural slope.
6. Removal of culverts, gates, and cattleguards if applicable.
7. Soil stabilization.
8. Erosion control.
9. Reseeding/revegetation.
10. Noxious weed control.
11. Vehicle/access barriers.
12. Monitoring schedule to ensure adequate reclamation.
13. Any other site-specific issues.

B. The Abandonment Plan must be approved by the Authorized Officer prior to any abandonment work. The operator or their representative will contact and schedule an on-site pre-abandonment meeting with the Authorized Officer prior to conducting any abandonment activities.

C. Upon termination of operator activities or facilities the following final reclamation requirements must be met (minimum timeframe of three growing seasons and initial reclamation activities were accepted by the Authorized Officer):

1. Established native vegetative cover is equal to 70% of the adjacent undisturbed areas.
2. The soil has been stabilized, and no excessive erosion exists.
3. There are no New Mexico Noxious Weed List Class A or B species or USDA Federal Noxious Weed List species present. If any of these noxious weed

species are identified, a treatment plan will be required. If New Mexico Noxious Weed List Class C or Watch List species are identified the Authorized Officer will determine if a treatment plan is required.

4. There are no signs of unauthorized motor vehicle use.
5. No garbage, litter, or waste is present.

The Authorized Officer may require the operator to submit a report detailing these conditions prior to approval of final reclamation. Additional measures may be required by the Authorized Officer to correct any identified issues.

- D. The operator is responsible for successful final reclamation regardless of weather or other factors.

I. Use of Unmanned Aircraft Systems (UAS)

- A. Use of any UAS for lease operations or activities requires prior Authorized Officer notification and approval.
- B. All UAS operations conducted per Federal Aviation Administration (FAA) compliance within the provisions of Part 107 for commercial use must have:
 1. Aircraft registration.
 2. Remote pilot certificate with a Small Unmanned Aircraft System (sUAS) rating.
- C. All UAS operations conducted outside of FAA compliance within the provisions of Part 107 for commercial use must have:
 1. Aircraft registration.
 2. Remote Pilot certificate with a sUAS rating.
 3. Waiver(s) to the specific aspect of Part 107 to operate outside of OR a 333 exemption and Certificate of Waiver or Authorization (COA) (There is a 400' AGL and below blanket COA that could be used with the separate 333 exemption).
- D. Any UAS mishap or accident must be reported per FAA laws and regulations. Also, the Authorized Officer must be notified of any mishap or accident that is reportable to the FAA.
- E. The operator is responsible for recovery and retrieval of any hazardous material or equipment lost as a result of UAS operations. Also, the operator is responsible for any damage or liability arising from UAS operations.

J. Inspection, Enforcement, and Compliance

- A. All operations on NFS lands may be inspected periodically by the Authorized Officer or other applicable regulatory agencies. Inspections of leasehold operations are made to ensure compliance with applicable laws, regulations, lease terms, the APD and its SUPO with conditions of approval, Onshore Oil and Gas Orders, NTLs, and other written orders of the Authorized Officer. Operators are expected to initiate their own inspection programs, identify noncompliance, and take appropriate corrective actions, rather than relying on outside inspections to identify problems.

- B. The operator will abide by all applicable federal, state, and local laws and regulations while conducting lease activities and operations. It is the responsibility of the operator to obtain any required permit, license, certificate, authorization, etc. required for construction activities, or to conduct lease activities or operations.



United States Department of the Interior



BUREAU OF LAND MANAGEMENT
Farmington District Office
6251 College Blvd, Suite A
Farmington, New Mexico 87402

In Reply Refer To:
3162.3-1(NMF0110)

* LOGOS OPERATING LLC
#808H ROSA UNIT
APD ID: 10400108423

GENERAL REQUIREMENTS FOR OIL AND GAS OPERATIONS ON FEDERAL AND INDIAN LEASES

The following special requirements apply and are effective when **checked**:

- A. Note all surface/drilling conditions of approval attached.
- B. The required wait on cement (WOC) time will be a minimum of 500 psi compressive strength at 60 degrees. Blowout preventor (BOP) nipple-up operations may then be initiated
- C. Test all casing strings below the conductor casing to .22 psi/ft. of casing string length or 1500 psi, whichever is greater, but not to exceed 70% of the minimum internal yield (burst) for a minimum of 30 minutes. If pressure declines more than 10 percent in 30 minutes, corrective action shall be taken.
- D. Communitization Agreement covering the acreage dedicated to this well must be filed for approval with the Bureau of Land Management, New Mexico State Office, Reservoir Management Group, 301 Dinosaur Trail, Santa Fe, New Mexico 87508.
The effective date of the agreement must be **prior** to any sales.
- E. The use of co-flex hose is authorized contingent upon the following:
 1. From the BOP to the choke manifold: the co-flex hose must be hobbled on both ends and saddle to prevent whip.
 2. From the choke manifold to the discharge tank: the co-flex hoses must be as straight as practical, hobbled on both ends and anchored to prevent whip.
 3. The co-flex hose pressure rating must be at least commensurate with approved BOPE.

INTERIOR REGION 7 • UPPER COLORADO BASIN

COLORADO, NEW MEXICO, UTAH, WYOMING

I. GENERAL

- A. Full compliance with all applicable laws and regulations, with the approved Permit to drill, and with the approved Surface Use and Operations Plan is required. Lessees and/or operators are fully accountable for the actions of their contractors and subcontractors. Failure to comply with these requirements and the filing of required reports will result in strict enforcement pursuant to 43 CFR 3163.1 or 3163.2.
- B. Each well shall have a well sign in legible condition from spud date to final abandonment. The sign should show the operator's name, lease serial number, or unit name, well number, location of the well, and whether lease is Tribal or Allotted, (See 43 CFR 3162.6(b)).
- C. A complete copy of the approved Application for Permit to Drill, along with any conditions of approval, shall be available to authorized personnel at the drill site whenever active drilling operations are under way.
- D. For Wildcat wells only, a drilling operations progress report is to be submitted, to the BLM-Field Office, weekly from the spud date until the well is completed and the Well Completion Report is filed. The report should be on 8-1/2 x 11 inch paper, and each page should identify the well by; operator's name, well number, location and lease number.
- E. As soon as practical, notice is required of all blowouts, fires and accidents involving life-threatening injuries or loss of life. (See NTL-3A).
- F. BOP equipment (except the annular preventer) shall be tested utilizing a test plug to full working pressure for 10 minutes. No bleed-off of pressure is acceptable. (See 43 CFR 3172.6(b)(9)(ii)).
- G. The operator shall have sufficient weighting materials and lost circulation materials on location in the event of a pressure kick or in the event of lost circulation. (See 43 CFR 3172.8(a)).
- H. The flare line(s) discharge shall be located not less than 100 feet from the well head, having straight lines unless turns are targeted with running tees, and shall be positioned downwind of the prevailing wind direction and shall be anchored. The flare system shall have an effective method for ignition. Where noncombustible gas is likely or expected to be vented, the system shall be provided supplemental fuel for ignition and to maintain a continuous flare. (See 43 CFR 3172.8(b)(7)).
- I. Prior approval by the BLM-Authorized Office (Drilling and Production Section) is required for variance from the approved drilling program and before commencing plugging operations, plug back work, casing repair work, corrective cementing operations, or suspending drilling operations indefinitely. Emergency approval may be obtained orally, but such approval is contingent upon filing of a Notice of Intent sundry within three business days. **Any changes to the approved plan or any questions regarding drilling operations should be directed to BLM during regular business hours at 505-564-7600. Emergency program changes after hours should be directed to Virgil Lucero at 505-793-1836.**
- J. **The Inspection and Enforcement Section (I&E), phone number (505-564-7750) is to be notified at least 24 hours in advance of BOP test, spudding, cementing, or plugging operations so that a BLM representative may witness the operations.**

- K. From the time drilling operations are initiated and until drilling operations are completed, a member of the drilling crew or the tool pusher shall maintain rig surveillance at all times, unless the well is secured with blowout preventers or cement plugs.
- L. If for any reason, drilling operations are suspended for more than 90 days, a written notice must be provided to this office outlining your plans for this well.
- M. **Commingling:** No production (oil, gas, and water) from the subject well should start until Sundry Notices (if necessary) granting variances from applicable regulations as related to commingling and off-lease measurement are approved by this office. (See 43 CFR 3173.14)

II. REPORTING REQUIREMENTS

- A. For reporting purposes, all well Sundry notices, well completion and other well actions shall be referenced by the appropriate lease, communitization agreement and/or unit agreement numbers.
- B. The following reports shall be filed with the BLM-Authorized Officer online through AFMSS 2 within 30 days after the work is completed.
 - 1. Provide complete information concerning.
 - a. Setting of each string of casing. Show size and depth of hole, grade and weight of casing, depth set, depth of all cementing tools that are used, amount (in cubic feet) and types of cement used, whether cement circulated to surface and all cement tops in the casing annulus, casing test method and results, and the date work was done. Show spud date on first report submitted.
 - b. Intervals tested, perforated (include size, number and location of perforations), acidized, or fractured; and results obtained. Provide date work was done on well completion report and completion sundry notice.
 - c. Subsequent Report of Abandonment, show the way the well was plugged, including depths where casing was cut and pulled, intervals (by depths) where cement plugs were replaced, and dates of the operations.
 - 2. Well Completion Report will be submitted with 30 days after well has been completed.
 - a. Initial Bottom Hole Pressure (BHP) for the producing formations. Show the BHP on the completion report. The pressure may be: 1) measured with a bottom hole bomb, or; 2) calculated based on shut in surface pressures (minimum seven day buildup) and fluid level shot.
 - 3. Submit a cement evaluation log if cement is not circulated to surface.
- C. Production Startup Notification is required no later than the 5th business day after any well begins production on which royalty is due anywhere on a lease site or allocated to a lease site or resumes production in the case of a well which has been off production for more than 90 days. The operator shall notify the Authorized Officer by letter or Sundry Notice, Form 3160-5, or orally to be followed by a letter or Sundry Notice, of the date on which such production has begun or resumed. CFR 43 3162.4-1(c).

III. DRILLER'S LOG

The following shall be entered in the daily driller's log: 1) Blowout preventer pressures tests, including test pressures and results, 2) Blowout preventer tests for proper functioning, 3) Blowout prevention drills conducted, 4) Casing run, including size, grade, weight, and depth set, 5) How pipe was cemented, including amount of cement, type, whether cement circulated to surface, location of cementing tools, etc., 6) Waiting on cement time for each casing string, 7) Casing pressure tests after cementing, including test pressure and results, and 8) Estimated amounts of oil and gas recovered and/or produced during drill stem test.

IV. GAS FLARING

Gas produced from this well may not be vented or flared beyond an initial, authorized test period of *** Days**, 20 MMCF following its (completion)(recompletion), or flowback has been routed to the production separator, whichever first occurs, without the prior, written approval of the authorized officer in accordance with 43 CFR 3179.81. Should gas be vented or flared without approval beyond the test period authorized above, you may be directed to shut-in the well until the gas can be captured or approval to continue venting or flaring as uneconomic is granted. You shall be required to compensate the lessor for the portion of the gas vented or flared without approval which is determined to have been avoidably lost.

***30 days**, unless a longer test period is specifically approved by the authorized officer. The 30-day period will commence upon the beginning of flowback following completion or recompletion.

V. SAFETY

- A. All rig heating stoves are to be of the explosion-proof type.
- B. Rig safety lines are to be installed.
- C. Hard hats and other Personal Protective Equipment (PPE) must be utilized.

VI. CHANGE OF PLANS OR ABANDONMENT

- A. Any changes of plans required to mitigate unanticipated conditions encountered during drilling operations, will require approval as set forth in Section 1.I.
- B. If the well is dry, it is to be plugged in accordance with 43 CFR 3162.3-4, approval of the proposed plugging program is required as set forth in Section 1.I. The report should show the total depth reached, the reason for plugging, and the proposed intervals, by depths, where cement plugs are to be placed, type of plugging mud, etc. A Subsequent Report of Abandonment is required as set forth in Section II.B.1c.
- C. Unless a well has been properly cased and cemented, or properly plugged, the drilling rig must not be moved from the drill site without prior approval from the BLM-Authorized Officer.

VII. PHONE NUMBERS

- A. For BOPE tests, cementing, and plugging operations the phone number is 505-564-7750 and must be called 24 hours in advance in order that a BLM representative may witness the operations.

C-102 Submit Electronically Via OCD Permitting	State of New Mexico Energy, Minerals & Natural Resources Department OIL CONSERVATION DIVISION	Revised July 9, 2024 Submittal Type <input checked="" type="checkbox"/> Initial Submittal <input type="checkbox"/> Amended Report <input type="checkbox"/> As Drilled
--	--	---

WELL LOCATION INFORMATION

API Number 30-039-31515	Pool Code 97232	Pool Name BASIN MANCOS
Property Code 320608	Property Name ROSA UNIT	Well Number 808H
OGRID No. 289408	Operator Name LOGOS OPERATING, LLC	Ground Level Elevation 6593'
Surface Owner: <input type="checkbox"/> State <input type="checkbox"/> Fee <input type="checkbox"/> Tribal <input checked="" type="checkbox"/> Federal		Mineral Owner: <input type="checkbox"/> State <input type="checkbox"/> Fee <input type="checkbox"/> Tribal <input checked="" type="checkbox"/> Federal

Surface Location

UL	Section	Township	Range	Lot	Feet from N/S Line	Feet from E/W Line	Latitude	Longitude	County
K	24	31N	5W		1826' SOUTH	1754' WEST	36.882853 °N	-107.316590 °W	RIO ARRIBA

Bottom Hole Location

UL	Section	Township	Range	Lot	Feet from N/S Line	Feet from E/W Line	Latitude	Longitude	County
P	20	31N	4W		900' SOUTH	32' EAST	36.880314 °N	-107.269414 °W	RIO ARRIBA

Penetrated Spacing Unit

Dedicated Acres 946.71	S/2 - Section 19, T31N, R4W S/2 - Section 20, T31N, R4W S/2 - Section 24, T31N, R5W	Infill or Defining Well INFILL	Defining Well API	Overlapping Spacing Unit <input type="checkbox"/> Yes <input checked="" type="checkbox"/> No	Consolidation Code UNITIZATION
Order Numbers R-13457	Well setbacks are under Common Ownership: <input type="checkbox"/> Yes <input checked="" type="checkbox"/> No				

Kick Off Point (KOP)

UL	Section	Township	Range	Lot	Feet from N/S Line	Feet from E/W Line	Latitude	Longitude	County
N	24	31N	5W		1060' SOUTH	1815' WEST	36.880749 °N	-107.316377 °W	RIO ARRIBA

First Take Point (FTP)

UL	Section	Township	Range	Lot	Feet from N/S Line	Feet from E/W Line	Latitude	Longitude	County
N	24	31N	5W		975' SOUTH	2451' WEST	36.880518 °N	-107.314204 °W	RIO ARRIBA

Last Take Point (LTP)

UL	Section	Township	Range	Lot	Feet from N/S Line	Feet from E/W Line	Latitude	Longitude	County
P	20	31N	4W		900' SOUTH	32' EAST	36.880314 °N	-107.269414 °W	RIO ARRIBA

Unitized Area or Area of Uniform Interest ROSA UNIT	Spacing Unit Type <input checked="" type="checkbox"/> Horizontal <input type="checkbox"/> Vertical <input type="checkbox"/> Directional	Ground Floor Elevation 6623'
--	--	---------------------------------

OPERATOR CERTIFICATION

I hereby certify that the information contained herein is true and complete to the best of my knowledge and belief, and, if the well is a vertical or directional well, that this organization either owns a working interest or unleased mineral interest in the land including the proposed bottom hole location or has a right to drill this well at this location pursuant to a contract with an owner of a working interest or unleased mineral interest, or to a voluntary pooling agreement or a compulsory pooling order heretofore entered by the division.

If this well is a horizontal well, I further certify that this organization has received the consent of at least one lessee or owner of a working interest or unleased mineral interest in each tract (in the target pool or formation) in which any part of the well's completed interval will be located or obtained a compulsory pooling order from the division.

6/2/2025

Signature: Etta Trujillo Date: _____

Printed Name: **Etta Trujillo**

E-mail Address: etrujillo@logosresourcesllc.com

SURVEYOR CERTIFICATION

I hereby certify that the well location shown on this plat was plotted from field notes of actual surveys made by me or under my supervision, and that the same is true and correct to the best of my belief.



JASON C. EDWARDS

Signature and Seal of Professional Surveyor

Certificate Number: 15269 Date of Survey: SEPTEMBER 20, 2023

(RECORD) NO *01'W 2640.00'
 (RECORD) NO *18'44"W 2636.24'
 (RECORD) NO *22'18"W 2632.81'
 (MEASURED)

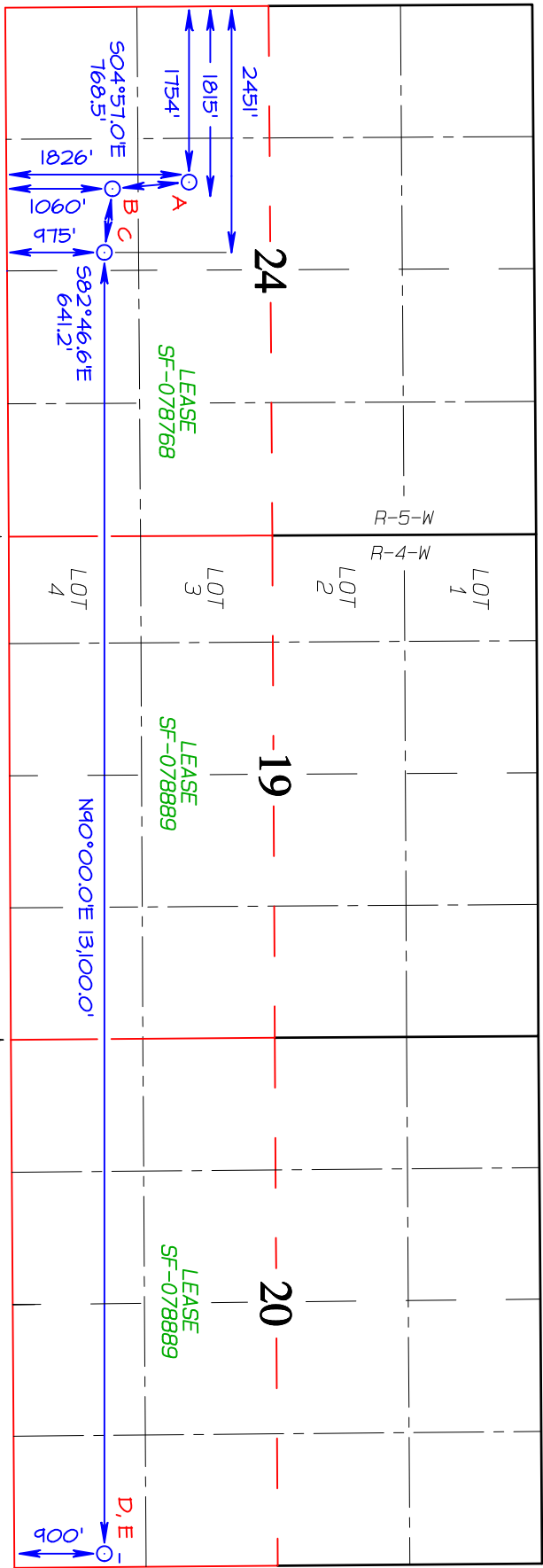

(RECORD) 589 *34'20"W 2637.76'
 (RECORD) 589 *56'W 2643.30'
 (RECORD) 589 *36'32"W 2653.88'
 (RECORD) 589 *56'W 2643.30'
 (RECORD) 589 *41'27"E 2382.48'
 (RECORD) 589 *58'E 2416.26'
 (RECORD) 589 *46'48"E 2631.12'
 (RECORD) 589 *58'E 2640.00'
 (RECORD) 589 *34'10"W 2627.10'
 (RECORD) 589 *58'W 2638.68'
 (RECORD) 589 *38'55"W 2642.02'
 (RECORD) 589 *58'W 2638.68'

(MEASURED) 589 *36'52"W 2628.97'
 (RECORD) 589 *57'W 2642.31'
 (MEASURED) 589 *37'47"W 2655.85'
 (RECORD) 589 *57'W 2642.31'
 (MEASURED) 589 *46'18"E 2387.61'
 (RECORD) 589 *56'E 2422.20'
 (MEASURED) 589 *44'47"E 2638.00'
 (RECORD) 589 *56'E 2640.00'
 (MEASURED) 589 *35'17"W 2645.67'
 (RECORD) 589 *59'W 2640.00'
 (MEASURED) 589 *37'47"W 2628.16'
 (RECORD) 589 *59'W 2640.00'

(MEASURED) NO *16'11"W 2635.01'
 (RECORD) NORTH 2640.00'
 (MEASURED) NO *27'58"W 2639.24'
 (RECORD) NO *03'W 2640.00'

(RECORD) NORTH 2640.00'
 (MEASURED) NO *15'57"W 2636.95'
 (RECORD) NO *03'W 2640.00'
 (MEASURED) NO *19'48"W 2634.56'

SURFACE LOCATION (A)
 1826' FSL 1754' FWL
 SECTION 24, T31N, R5W
 LAT 36.882847°N
 LONG -107.315989°W
 DATUM: NAD1983

KICK OFF POINT (B)
 1060' FSL 1815' FWL
 SECTION 24, T31N, R5W
 LAT 36.880743°N
 LONG -107.315776°W
 DATUM: NAD1927

FIRST TAKE POINT (C)
 975' FSL 2451' FWL
 SECTION 24, T31N, R5W
 LAT 36.880512°N
 LONG -107.313603°W
 DATUM: NAD1927

LAST TAKE POINT (D)
 900' FSL 32' FEL
 SECTION 20, T31N, R4W
 LAT 36.880307°N
 LONG -107.268815°W
 DATUM: NAD1927

BOTTOM HOLE LOCATION (E)
 900' FSL 32' FEL
 SECTION 20, T31N, R4W
 LAT 36.880307°N
 LONG -107.268815°W
 DATUM: NAD1927

SO4*ST.01E 768.5'
 SO4*ST.01E 13100.0'
 SF-078768 LEASE
 SF-078889 LEASE
 SF-078889 LEASE

LAT 36.882853°N
 LONG -107.316590°W
 DATUM: NAD1983

LAT 36.880749°N
 LONG -107.316377°W
 DATUM: NAD1983

LAT 36.880518°N
 LONG -107.314204°W
 DATUM: NAD1983

LAT 36.880314°N
 LONG -107.269414°W
 DATUM: NAD1983

LAT 36.880314°N
 LONG -107.269414°W
 DATUM: NAD1983

(MEASURED) NO *27'26"W 2632.77'
 (RECORD) NO *02'W 2640.00'
 (MEASURED) NO *26'29"W 2640.99'
 (RECORD) NO *02'W 2640.00'

State of New Mexico
 Energy, Minerals and Natural Resources Department

Submit Electronically
 Via E-permitting

Oil Conservation Division
 1220 South St. Francis Dr.
 Santa Fe, NM 87505

NATURAL GAS MANAGEMENT PLAN

This Natural Gas Management Plan must be submitted with each Application for Permit to Drill (APD) for a new or recompleted well.

Section 1 – Plan Description Effective May 25, 2021

I. Operator: LOGOS Operating, LLC **OGRID:** 289408 **Date:** 11/07/2025

II. Type: Original Amendment due to 19.15.27.9.D(6)(a) NMAC 19.15.27.9.D(6)(b) NMAC Other.

If Other, please describe: _____

III. Well(s): Provide the following information for each new or recompleted well or set of wells proposed to be drilled or proposed to be recompleted from a single well pad or connected to a central delivery point.

Well Name	API	ULSTR	Footages	Anticipated Oil BBL/D	Anticipated Gas MCF/D	Anticipated Produced Water BBL/D
Rosa Unit 800H	30-039-	K 24 T31N R5W	1903 FSL 1690 FWL	N/A	17,588	584
Rosa Unit 802H	30-039-	K 24 T31N R5W	1884 FSL 1706 FWL	N/A	17,606	584
Rosa Unit 804H	30-039-	K 24 T31N R5W	1865 FSL 1722 FWL	N/A	20,210	647
Rosa Unit 806H	30-039-	K 24 T31N R5W	1845 FSL 1738 FWL	N/A	20,210	647
Rosa Unit 808H	30-039-	K 24 T31N R5W	1826 FSL 1754 FWL	N/A	20,210	647

IV. Central Delivery Point Name: Harvest Gathering System [See 19.15.27.9(D)(1) NMAC]

V. Anticipated Schedule: Provide the following information for each new or recompleted well or set of wells proposed to be drilled or proposed to be recompleted from a single well pad or connected to a central delivery point.

Well Name	API	Spud Date	TD Reached Date	Completion Commencement Date	Initial Flow Back Date	First Production Date
Rosa Unit 800H	30-039-	Pending	Pending	Pending	Pending	Pending
Rosa Unit 802H	30-039-	Pending	Pending	Pending	Pending	Pending
Rosa Unit 804H	30-039-	Pending	Pending	Pending	Pending	Pending
Rosa Unit 806H	30-039-	Pending	Pending	Pending	Pending	Pending
Rosa Unit 808H	30-039-	Pending	Pending	Pending	Pending	Pending

VI. Separation Equipment: Attach a complete description of how Operator will size separation equipment to optimize gas capture.

VII. Operational Practices: Attach a complete description of the actions Operator will take to comply with the requirements of Subsection A through F of 19.15.27.8 NMAC.

VIII. Best Management Practices: Attach a complete description of Operator’s best management practices to minimize venting during active and planned maintenance.

Section 2 – Enhanced Plan
EFFECTIVE APRIL 1, 2022

Beginning April 1, 2022, an operator that is not in compliance with its statewide natural gas capture requirement for the applicable reporting area must complete this section.

Operator certifies that it is not required to complete this section because Operator is in compliance with its statewide natural gas capture requirement for the applicable reporting area.

IX. Anticipated Natural Gas Production:

Well	API	Anticipated Average Natural Gas Rate MCF/D	Anticipated Volume of Natural Gas for the First Year MCF

X. Natural Gas Gathering System (NGGS):

Operator	System	ULSTR of Tie-in	Anticipated Gathering Start Date	Available Maximum Daily Capacity of System Segment Tie-in

XI. Map. Attach an accurate and legible map depicting the location of the well(s), the anticipated pipeline route(s) connecting the production operations to the existing or planned interconnect of the natural gas gathering system(s), and the maximum daily capacity of the segment or portion of the natural gas gathering system(s) to which the well(s) will be connected.

XII. Line Capacity. The natural gas gathering system will will not have capacity to gather 100% of the anticipated natural gas production volume from the well prior to the date of first production.

XIII. Line Pressure. Operator does does not anticipate that its existing well(s) connected to the same segment, or portion, of the natural gas gathering system(s) described above will continue to meet anticipated increases in line pressure caused by the new well(s).

Attach Operator’s plan to manage production in response to the increased line pressure.

XIV. Confidentiality: Operator asserts confidentiality pursuant to Section 71-2-8 NMSA 1978 for the information provided in Section 2 as provided in Paragraph (2) of Subsection D of 19.15.27.9 NMAC, and attaches a full description of the specific information for which confidentiality is asserted and the basis for such assertion.

Section 3 - Certifications

Effective May 25, 2021

Operator certifies that, after reasonable inquiry and based on the available information at the time of submittal:

Operator will be able to connect the well(s) to a natural gas gathering system in the general area with sufficient capacity to transport one hundred percent of the anticipated volume of natural gas produced from the well(s) commencing on the date of first production, taking into account the current and anticipated volumes of produced natural gas from other wells connected to the pipeline gathering system; or

Operator will not be able to connect to a natural gas gathering system in the general area with sufficient capacity to transport one hundred percent of the anticipated volume of natural gas produced from the well(s) commencing on the date of first production, taking into account the current and anticipated volumes of produced natural gas from other wells connected to the pipeline gathering system.

If Operator checks this box, Operator will select one of the following:

Well Shut-In. Operator will shut-in and not produce the well until it submits the certification required by Paragraph (4) of Subsection D of 19.15.27.9 NMAC; or

Venting and Flaring Plan. Operator has attached a venting and flaring plan that evaluates and selects one or more of the potential alternative beneficial uses for the natural gas until a natural gas gathering system is available, including:

- (a) power generation on lease;
- (b) power generation for grid;
- (c) compression on lease;
- (d) liquids removal on lease;
- (e) reinjection for underground storage;
- (f) reinjection for temporary storage;
- (g) reinjection for enhanced oil recovery;
- (h) fuel cell production; and
- (i) other alternative beneficial uses approved by the division.

Section 4 - Notices

1. If, at any time after Operator submits this Natural Gas Management Plan and before the well is spud:

(a) Operator becomes aware that the natural gas gathering system it planned to connect the well(s) to has become unavailable or will not have capacity to transport one hundred percent of the production from the well(s), no later than 20 days after becoming aware of such information, Operator shall submit for OCD's approval a new or revised venting and flaring plan containing the information specified in Paragraph (5) of Subsection D of 19.15.27.9 NMAC; or

(b) Operator becomes aware that it has, cumulatively for the year, become out of compliance with its baseline natural gas capture rate or natural gas capture requirement, no later than 20 days after becoming aware of such information, Operator shall submit for OCD's approval a new or revised Natural Gas Management Plan for each well it plans to spud during the next 90 days containing the information specified in Paragraph (2) of Subsection D of 19.15.27.9 NMAC, and shall file an update for each Natural Gas Management Plan until Operator is back in compliance with its baseline natural gas capture rate or natural gas capture requirement.

2. OCD may deny or conditionally approve an APD if Operator does not make a certification, fails to submit an adequate venting and flaring plan which includes alternative beneficial uses for the anticipated volume of natural gas produced, or if OCD determines that Operator will not have adequate natural gas takeaway capacity at the time a well will be spud.

I certify that, after reasonable inquiry, the statements in and attached to this Natural Gas Management Plan are true and correct to the best of my knowledge and acknowledge that a false statement may be subject to civil and criminal penalties under the Oil and Gas Act.

Signature:	<i>Etta Trujillo</i>
Printed Name:	Etta Trujillo
Title:	Regulatory Specialist II
E-mail Address:	etrujillo@logosresourcesllc.com
Date:	11/07/2025
Phone:	(505) 324-4154

OIL CONSERVATION DIVISION
(Only applicable when submitted as a standalone form)

Approved By:
Title:
Approval Date:
Conditions of Approval:

VI. Separation Equipment

The operator will select separation equipment for the maximum anticipated throughput and pressure to optimize gas capture. Separation equipment is sized according to manufacturer's design specifications. Separation vessels are built following the A.S.M.E. section VII division 1 codes for pressure vessel design, fabrication, inspection, testing and certification. Anticipated well pressures and production rates are evaluated to select separation equipment according to the equipment's designed operating pressure and throughput.

After completion, the operator utilizes flowback equipment, including separators, to manage wellbore fluids and solids during the initial separation period. After the initial flowback period is complete the operator utilizes iterative facility separation equipment to ensure that optimal separation is achieved.

VII. Operational Practices 19.15.27.8 NMAC A through F

- A. The operator will maximize the recovery of natural gas and minimize the amount of gas vented or flared when technically and safely feasible as further described and detailed within the following subsections (B-F of 19.15.27.8). In all cases where natural gas venting and flaring requires regulatory reporting, reporting will be submitted accurately and within the required time frames.
- B. Venting and flaring during drilling operations:
 - a. New Drill HZ Oil Wells: The operator drills wells in the area by utilizing a balanced mud to safely drill the wellbore. This technique prevents gas from coming to surface during the drilling process. If there is an emergency or malfunction and natural gas does come to surface the natural gas will be captured or combusted, with an appropriately sized and located flare stack, if technically and safely feasible.
 - b. New Drill HZ Gas Wells: The operator drills wells in the area by balancing the mud weight to safely drill the wellbore with as minimal flaring as possible. When gas kicks enter the wellbore, sometimes it is necessary to circulate it out of the wellbore to an appropriately sized and located flare stack. The operator will estimate the volume flared and appropriately report.
- C. Venting and flaring during completion or recompletion operations:
 - a. New Drill HZ Oil Wells: The operator's facilities are designed to handle the maximum throughput and pressures from the newly drilled and completed wellbores. The amount of gas vented and flared will be minimized when technically and safely feasible. During initial flowback and initial separation flowback the operator will utilize contracted flowback equipment, including separators, to manage wellbore fluids and solids. The initial flowback period will be minimized and flow will be sent to separation equipment as soon as possible to reduce the amount of gas that is vented to atmosphere. During the separation flowback period natural gas will be routed to a properly sized and located flare until the natural gas is of pipeline quality (less than 60 days). The natural gas will also be utilized on site as needed for fuel gas or injection gas.
 - b. New Drill HZ Gas Wells: The operator's facilities are designed to handle the maximum throughput and pressures from the newly drilled and completed wellbores. The amount of gas vented and flared will be minimized when technically and safely feasible. During initial flowback and initial separation flowback the operator will utilize contracted flowback equipment, including separators, to manage wellbore fluids and solids. The initial flowback period will be minimized and flow will be sent to separation equipment as soon as possible to reduce the amount of gas that is vented to atmosphere. The natural gas will be utilized on site as needed for fuel gas and natural gas will be sold.
- D. Venting and flaring during production operations:

- a. New Drill HZ Oil Wells: The operator's facilities are designed to handle the maximum throughput and pressures from producing wellbores. The amount of gas vented and flared will be minimized when technically and safely feasible. This facility will operate under a notice of intent (NOI) from the New Mexico Environment Department (NMED).

Operations will effectively manage the following scenarios to minimize the quantity of natural gas that is vented or flared:

- (a) If there is an emergency or malfunction, vented or flared natural gas will be reported, if required, and the emergency or malfunction will be resolved as soon as technically and safely feasible.
- (b) If the wellbore requires liquids to be unloaded to atmosphere, the operator will not vent the well after the well has achieved a stabilized rate and pressure. The operator will remain on site during unloading. Plunger lift systems will be optimized to reduce the amount of natural gas venting. Downhole maintenance, such as workovers, swabbing, etc. will only be conducted as needed and best management practices will be utilized to reduce venting of natural gas.
- (c) The operator will minimize the amount of time that natural gas is vented to atmosphere from gauging and sampling a storage tank or low-pressure vessel, automatic tank gauges will be the primary means of gauging with minor exceptions.
- (d) The operator will reduce the amount of time needed for loading out liquids from a storage tanks or other low-pressure vessels whenever feasible. Operations will utilize a LACT system when available to minimize gas vented during oil tank loading.
- (e) Equipment will be repaired and maintained routinely to minimize the venting or flaring of natural gas. Repairs and maintenance will be conducted in a manner that minimizes the amount of natural gas vented to atmosphere through the isolation of the equipment that is being repaired or maintained.
- (f) Electric controllers and pumps will be installed to replace pneumatic controllers whenever feasible. Pneumatic controllers and pumps will be inspected frequently to ensure that no excess gas is vented to atmosphere.
- (g) Storage tanks and other low-pressure vessel normal operational venting will be minimized during the early life of the well with the installation of a vapor recovery unit to limit the flash and working and breathing emissions to atmosphere.
- (h) No dehydration or amine units are anticipated to be set on location.
- (i) Compressors, compressor engines, turbines, flanges, connectors, valves, and flanges will be routinely inspected to ensure that no excess venting occurs outside of normal operation.
- (j) Regulatory required testing, such as bradenhead and packer testing will be performed in a manner that minimizes the amount of natural gas vented to atmosphere.
- (k) When natural gas does not meet gathering pipeline specifications, for example high nitrogen content after a nearby frac, gas samples will be collected twice per week to determine when pipeline specification gas content has been achieved. During this time frame gas will be flared and not vented to atmosphere. Natural gas that meets pipeline specifications will be sold via pipeline and natural gas that can be utilized for fuel gas will be used during this time.
- (l) If pipeline, equipment, or facilities need purged of impurities gas losses will be minimized as much as technically and safely feasible.

- b. New Drill HZ Gas Wells: The operator's facilities are designed to handle the maximum throughput and pressures from producing wellbores. The amount of gas vented and flared will be minimized when technically and safely feasible.

Operations will effectively manage the following scenarios to minimize the quantity of natural gas that is vented or flared:

- (a) If there is an emergency or malfunction vented or flared natural gas will be reported, if required, and the emergency or malfunction will be resolved as soon as technically and safely feasible.
- (b) If the wellbore needs to be unloaded to atmosphere the operator will not vent the well after the well has achieved a stabilized rate and pressure. The operator will remain on site during unloading. Plunger lift systems will be optimized to reduce the amount of natural gas venting. Downhole maintenance, such as workovers, swabbing, etc. will only be conducted as needed and best management practices will be utilized to reduce venting of natural gas.
- (c) The operator will minimize the amount of time that natural gas is vented to atmosphere from gauging and sampling a storage tank or low-pressure vessel, automatic tank gauges will be the primary means of gauging. The formation is only anticipated to produce water and therefore tank emissions are anticipated to be negligible.
- (d) The operator will reduce the amount of time needed for loading out liquids from a storage tanks or other low-pressure vessels whenever feasible. Operations will always utilize the water transfer systems when available. Water loading emissions are anticipated to be negligible.
- (e) Equipment will be repaired and maintained routinely to minimize the venting or flaring of natural gas. Repairs and maintenance will be conducted in a manner that minimizes the amount of natural gas vented to atmosphere through the isolation of the equipment that is being repaired or maintained.
- (f) Electric controllers and pumps, or instrument air, will be installed to replace pneumatic controllers whenever feasible. Pneumatic controllers and pumps will be inspected frequently to ensure that no excess gas is vented to atmosphere.
- (g) No dehydration or amine units are anticipated to be set on location.
- (h) Compressors, compressor engines, turbines, flanges, connectors, valves, storage tanks, and other low-pressure vessels and flanges will be routinely inspected to ensure that no excess venting occurs outside of normal operations.
- (i) Regulatory required testing, such as bradenhead and packer testing will be performed in a manner that minimizes the amount of natural gas vented to atmosphere.
- (j) If natural gas does not meet gathering pipeline specifications gas samples will be collected twice per week to determine when pipeline specification gas content has been achieved. During this time frame gas will be flared and not vented to atmosphere. Natural gas that meets pipeline specifications will be sold via pipeline and natural gas that can be utilized for fuel gas will be used during this time.
- (k) If pipeline, equipment, or facilities need purged of impurities gas losses will be minimized as much as technically and safely feasible.

E. Performance standards:

- a. The production facilities are designed to handle the maximum throughput and pressures from producing wellbores and will be designed to minimize waste. The amount of gas vented and flared will be minimized when technically and safely feasible.

- b. All tanks that are routed to a control device that is installed after 5/25/2021 will have an automatic gauging system to minimize the amount of vented natural gas.
 - c. If a flare stack is installed or replaced after 5/25/2021 it will be equipped with an automatic ignitor or continuous pilot. The flare stack will be properly sized and designed to ensure proper combustion efficiency. The flare stack will be located 100 feet away from the nearest wellhead or storage tank.
 - d. AVO inspections will be conducted weekly for the year after completion and for all wells producing greater than 60,000 cubic feet of natural gas daily. The AVO inspection will include all components, including flare stacks, thief hatches, closed vent systems, pumps, compressors, pressure relief devices, valves, lines, flanges, connectors, and associated pipeline to identify any leaks and releases by comprehensive auditory, visual, and olfactory inspection. The AVO inspection records will be maintained for 5 years which will be available at the department's request. Identified leaks will be repaired as soon as feasible to minimize the amount of vented natural gas.
- F. Measurement or estimation of vented and flared natural gas.
- a. The volume of natural gas that is vented, flared or consumed for beneficial use will be measured when possible, or estimated, during drilling, completions, or production operations.
 - b. Equipment will be installed to measure the volume of natural gas flared for all APD's issued after 5/25/2021 on facilities that will have an average daily gas rate greater than 60,000 cubic feet of natural gas. Measurement equipment will conform to API MPMS Chapter 14.10 regulations. The measurement equipment will not have a manifold that allows the diversion of natural gas around the metering element except for the sole purpose of inspecting and servicing the measurement equipment. If metering is not practical, then the volume of gas will be estimated.



LOGOS Operating, LLC Operations Plan

Note: This procedure will be adjusted onsite based upon actual conditions

Date:	June 5, 2025	Pool:	Basin Mancos
Well Name:	Rosa Unit 808H	GL Elevation:	6,593'
Surface Location:	Sec 24, T31N, R5W 1826' FSL, 1754' FWL (36.882853° N, -107.316590° W – NAD83)	KB:	30'
Bottom Hole Location:	Sec 20, T31N, R4W 900' FSL, 32' FEL (36.880314° N, -107.269414° W – NAD83)	Measured Depth:	20,750' (KB)
Lease Serial CA Serial	# NMSF078768 # NMNM78407E	County:	Rio Arriba

I. GEOLOGY

A. Formation Tops (Based on KB Elevation): Estimated top of important geological markers:
SURFACE FORMATION – NACIMIENTO

NAME	MD	TVD	NAME	MD	TVD
OJO ALAMO	2,851'	2,834'	*POINT LOOKOUT	5,963'	5,920'
KIRTLAND	2,976'	2,957'	*MANCOS	6,512'	6,464'
*FRUITLAND	3,254'	3,233'	KICKOFF POINT	6,658'	6,609'
*PICTURED CLIFFS	3,709'	3,684'	LANDING POINT	7,650'	7,233'
LEWIS	3,808'	3,783'	TD	20,750'	7,243'
CHACRA	4,931'	4,896'			
*CLIFF HOUSE	5,746'	5,704'			
MENEFEE	5,780'	5,738'			

* indicates depth at which anticipated water, oil, gas or other mineral bearing formations are expected to be encountered.

B. **MUD LOGGING PROGRAM:** Mudlogger on location from KOP to TD.

C. **LOGGING PROGRAM:** LWD GR from surface casing to TD.

D. **NATURAL GAUGES:** Gauge any noticeable increases in gas flow. Record all gauges in Tour book and on morning reports.

II. DRILLING

A. **MUD PROGRAM:** LSND mud (WBM) will be used to drill the 17-1/2” surface hole and 12-1/4” intermediate hole. A LSND (WBM) or (OBM) will be used to drill the 8-1/2” curve and lateral portion of the wellbore. Treat for lost circulation as necessary. Obtain 100% returns prior to cementing. Notify Engineering of any mud losses.

Above ground steel pits will be used for fluid and cuttings while drilling. In the unlikely event that a tank develops a leak, upon immediate visual discovery, the fluid would be transferred to another tank and contaminated soil would be removed and disposed. Any leaks, spills or other undesirable events will be reported in accordance with BLM NTL 3A. Rig crews will monitor the tanks at all times.



- B. BOP TESTING:** The BOPE will be tested to **250 psi (Low) for 5 minutes** and **3000 psi (High) for 10 minutes**. Pressure test surface casing to **1500 psi for 30 minutes** and intermediate casing to **1500 psi for 30 minutes**. Utilize a BOPE Testing Unit with a recording chart and appropriate test plug for testing. The drum brakes will be inspected and tested each tour. BOP equipment will be tested every 30 days, after any repairs are made to the BOP equipment, and after the BOP equipment is subjected to pressure. Annular preventers will be functionally operated at least once per week. Pipe and blind rams shall be activated each trip or but not more than once a day. The New Mexico Oil & Gas Conservation Commission and the BLM will be notified 24 hours in advance of testing of BOPE. **All tests and inspections will be recorded and logged with time and results.** A full BOP test will be conducted when initially installed for the first well on the pad or if seals subject to test pressure are broken, following related repairs and at a minimum of 30 day intervals. A BOPE Shell Test only will be conducted for subsequent wells on the pad when seals subject to pressure have not been broken or repaired and fall within the 30 day interval of first full test.
- C. GeoHazards:** There are no Geohazards
- D. Maximum Anticipated Pressure:** $7,243' \text{ TVD} \times 0.43 = 3,115 \text{ psi}$
- E. H2S Concerns:** There is no record of any naturally occurring H2S in any formation in the Rosa Unit. No H2S is anticipated in this formation or this well.

III. MATERIALS

A. CASING EQUIPMENT:

CASING TYPE	OHSIZE (IN)	DEPTH (MD)	CSG SIZE	WEIGHT	GRADE	CONN
SURFACE (Pre-Set)	17.5"	320' (GL)	13-3/8"	54.5 LBS	J-55	BTC
INTERMEDIATE	12.25"	6,627'	9.625"	43.5 LBS	N-80 or equiv	LTC/BTC
PRODUCTION	8.5"	20,750'	5.5"	20 LBS	P-110 or equiv	LTC/BTC

NOTE: All casing depths are approximate, based on KB elevation and will be based on drilling conditions +/- 50'. Weights, grades and connections will be based on availability and may vary but will be equivalent or greater.

B. FLOAT EQUIPMENT:

- SURFACE CASING:** 13-3/8" cement nose guide shoe. Place float shoe 1 joint above shoe. Run (1) standard centralizer on each of the bottom (3) joints of Surface Casing.
- INTERMEDIATE CASING:** 9-5/8" cement float shoe. Place float collar one joint above the shoe. Install (1) centralizer on each of the bottom (3) joints and one standard centralizer every (3) joints to 2,500 ft. Run (1) centralizer at 2,500 ft., 2,300ft., 2,000ft., 1,500 ft., and 1,000 ft. Optional use of DV Tools (2) will be strategically placed above loss circulation zones anticipated in the Mesaverde and Fruitland Coal. Optional use of cancelation plugs for DV tools may be used if losses while cementing are not encountered. Optional use of an ICP may be used in conjunction with DV Tools.
- PRODUCTION CASING:** Run 5-1/2" casing with cement nose guide Float Shoe, 5-1/2" full or pup joints as necessary, Landing Collar, 5-1/2" full or pup joints as necessary, at least (1) one Toe Sleeve (Sliding Sleeve) positioned inside the applicable production area. Centralizer program will be determined by wellbore conditions. Production casing to be pressure tested during completion operations with frac stack installed.



C. CEMENTING:

(Note: Cement type and volumes may be adjusted onsite due to actual conditions and availability)

1. SURFACE:

Surface - 13-3/8", 54.5# csg	Top	Footage	Cement (ft3/ft) Annular Capacity	Excess (30%)	Total (ft3)	Total (bbl)	Slurry Yield (ft3/sk)	Sacks Cement	Density (PPG)
Type G	-	320	0.6946	1.3	339	60	1.15	295	15.8
or Type III		320	0.6946	1.3	339	60	1.39	244	14.6

Set Depth, ft RKB 320

2. INTERMEDIATE : Intermediate casing shall be kept fluid filled while running in to the hole to meet BLM minimum collapse requirements. The intermediate casing will be cemented in 2 or 3 stages using DV/STAGE tools in order to reduce cement losses and maximize cement coverage. Operator proposes optional DV tools and optional ICP's above anticipated loss circulation zones in the Mesaverde and in the Fruitland coal. If losses are not observed during the second stage a cancelation plug will be pumped and the remaining cement will be pumped during stage 2. If cement does not circulate to the DV tool(s) or to surface, a CBL will be run to determine TOC.

Intermediate - 9-5/8", 43.5# csg	Top	Footage	Cement (ft3/ft) Annular Capacity	Excess (30%)	Total (ft3)	Total (bbl)	Slurry Yield (ft3/sk)	Sacks Cement	Density (PPG)
Stage 1 Tail	6,127	500	0.3132	1.3	221	39	1.15	192	15.8
Stage 1 Lead	5,006	1,121	0.3132	1.3	456	81	2.66	172	11.8
					678	121		364	
Stage 2 Tail	4,406	600	0.3132	1.3	244	44	1.76	139	13.5
Stage 2 Lead	3,759	647	0.3132	1.3	263	47	2.66	99	11.8
					508	90		238	
Stage 3 Tail	3,109	650	0.3132	1.3	265	47	1.76	150	13.5
Stage 3 Lead	320	2,789	0.3132	1.3	1,136	202	2.66	427	11.8
Stage 3 Lead	-	320	0.3627	1	116	21	2.66	44	11.8
					1,516	270		621	
					2,702	481		1,223	

Set Depth, ft RKB 6627

Calculations based on 30% excess for open hole and cement to surface. Actual excess pumped will be determined by well conditions.

3. PRODUCTION: Production casing will be cemented in 1 stage with 100' of cement overlap above intermediate shoe. A CBL, or alternatively, a Temperature Survey will be used to determine TOC.

Production - 5-1/2", 20# csg	Top	ft	Cement (ft3/ft) Annular Capacity	Excess (15%)	Total (ft3)	Total (bbl)	Slurry Yield (ft3/sk)	Sacks Cement	Density (PPG)
Cased hole Tail	6,527	100	0.2531	1	25	5	2.03	12	13.2
Open Hole Tail	6,627	14,123	0.2291	1.15	3,731	665	2.03	1,838	13.2
					3,757	669		1,851	

Set Depth, ft RKB 20750



Cement calculations are used for volume estimation. Well conditions will dictate final cement job design. Actual volumes will be calculated and determined by conditions onsite. All cement slurries will meet or exceed minimum BLM and New Mexico Oil Conservation Division requirements. Slurries used will be the slurries listed above or equivalent slurries depending on service provider selected. Cement yields may change depending on slurries selected. All waiting on cement times shall be a minimum of 8 hours or adequate to achieve a minimum of 500 psi compressive strength at the casing shoe prior to drilling out.

IV. COMPLETION

A. CBL

CBLs and/or Temperature Surveys will be performed as needed or required to determine cement top if cement is not circulated.

B. PRESSURE TEST

C. Pressure test 5-1/2" casing to 0.22 psi/ft * 7,243' TVD = 1594 psi for 30 minutes. Increase pressure to Open RSI sleeves.

D. STIMULATION

Stimulate with sand and water. Isolate stages with flow through or dissolvable frac plugs. Drill out frac plugs and flowback lateral.

E. PRODUCTION TUBING

2-7/8", 6.5#, J-55 or L-80, EUE tubing will be run once volumes and pressures dictate. Due to the extremely high initial flow rates and pressures seen in offset wells, tubing will be installed once it is safe to do so, typically 12-36 months after completion.

*NOTE: Although this horizontal well may be drilled past the applicable setbacks, an unorthodox location application is not required because the completed interval in this well, as defined by 19.15.16.7 8(1) NMAC, will be entirely within the applicable setbacks. This approach complies with all applicable rules, including 19.15.16.14 A(3) NMAC, 19.15.16.14 8(2) NMAC, 19.15.16.15 8(2)NMAC, and 19.15.16.15. 8(4) NMAC.



3M 11" B.O.P.E Diagram

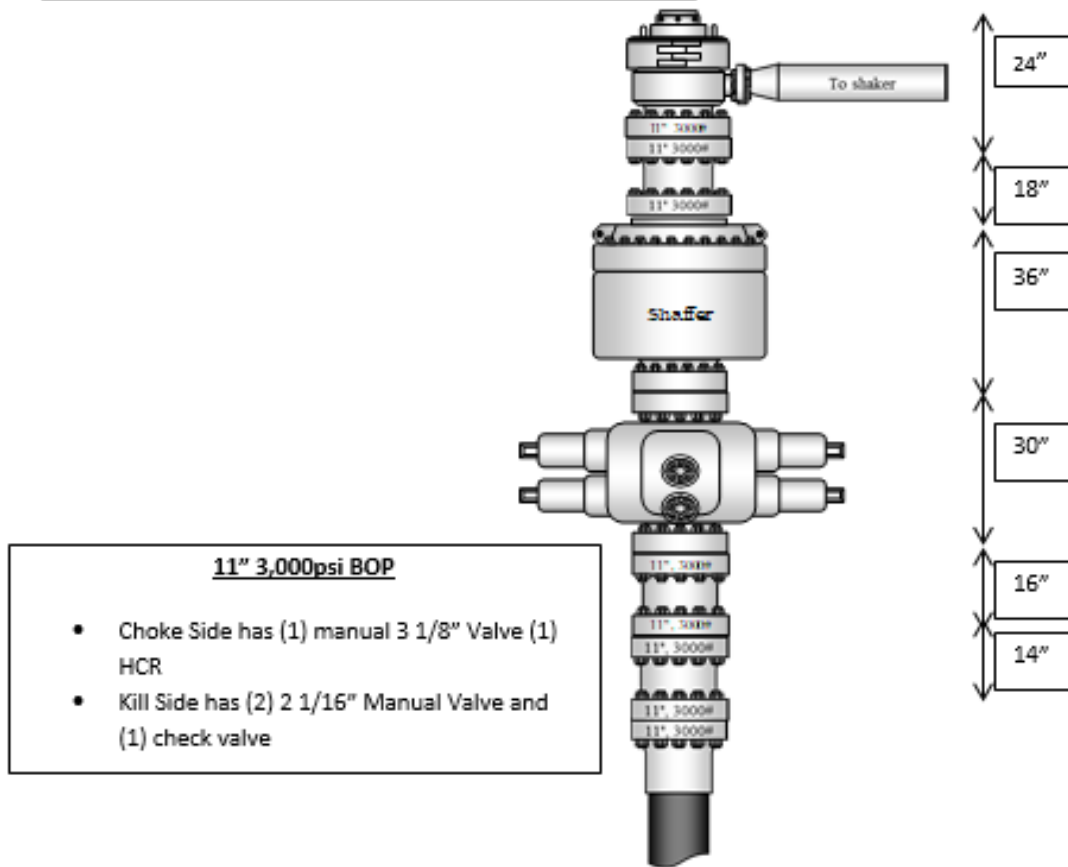
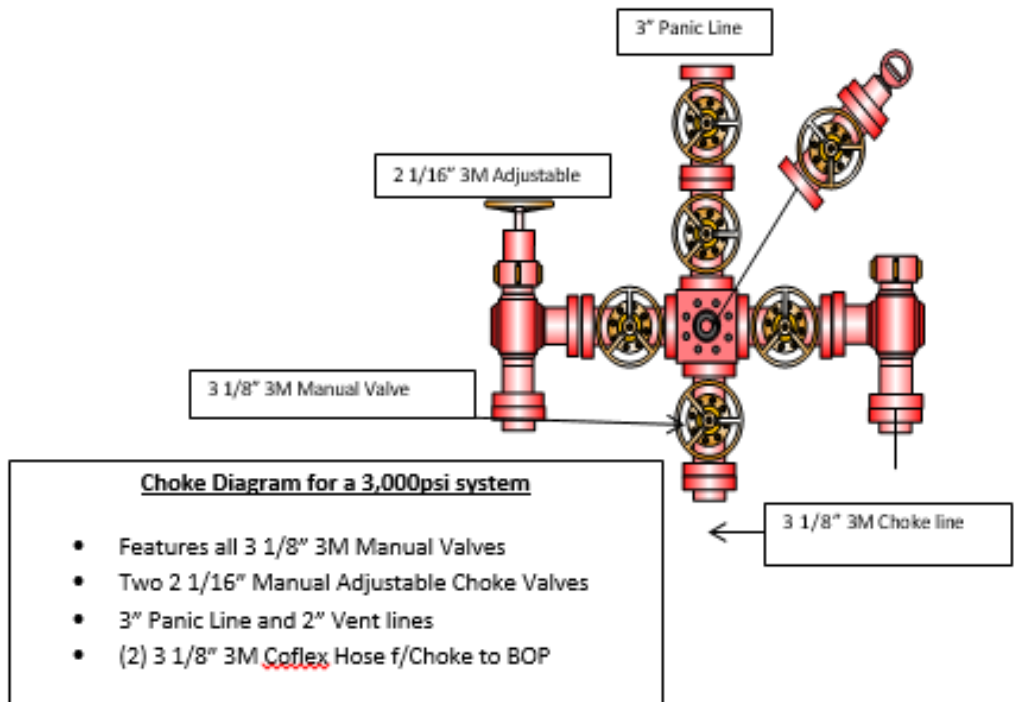

Logos Operating LLC

Rio Arriba, NM (NAD83)

Rosa Unit 38

Rosa Unit 808H

OH

Plan: Prelim 1

Standard Planning Report

03 April, 2025

SDT Planning Report

Database:	EDM 5000 Multi User Db	Local Co-ordinate Reference:	Well Rosa Unit 808H
Company:	Logos Operating LLC	TVD Reference:	6593+30 @ 6623.00usft (H&P 530)
Project:	Rio Arriba, NM (NAD83)	MD Reference:	6593+30 @ 6623.00usft (H&P 530)
Site:	Rosa Unit 38	North Reference:	True
Well:	Rosa Unit 808H	Survey Calculation Method:	Minimum Curvature
Wellbore:	OH		
Design:	Prelim 1		

Project	Rio Arriba, NM (NAD83)		
Map System:	US State Plane 1983	System Datum:	Mean Sea Level
Geo Datum:	North American Datum 1983		
Map Zone:	New Mexico Western Zone		

Site	Rosa Unit 38				
Site Position:		Northing:	2,141,169.58 usft	Latitude:	36.883065
From:	Lat/Long	Easting:	2,874,152.79 usft	Longitude:	-107.316807
Position Uncertainty:	0.00 usft	Slot Radius:	13-3/16 "		

Well	Rosa Unit 808H					
Well Position	+N/-S	0.00 usft	Northing:	2,141,092.74 usft	Latitude:	36.882853
	+E/-W	0.00 usft	Easting:	2,874,216.67 usft	Longitude:	-107.316590
Position Uncertainty		0.00 usft	Wellhead Elevation:	usft	Ground Level:	6,593.00 usft
Grid Convergence:	0.31 °					

Wellbore	OH				
Magnetics	Model Name	Sample Date	Declination (°)	Dip Angle (°)	Field Strength (nT)
	IGRF2015	12/31/2019	8.83	63.50	49,898.24171720

Design	Prelim 1			
Audit Notes:				
Version:	Phase:	PLAN	Tie On Depth:	0.00
Vertical Section:	Depth From (TVD) (usft)	+N/-S (usft)	+E/-W (usft)	Direction (°)
	0.00	0.00	0.00	90.31

Plan Survey Tool Program	Date	4/3/2025			
Depth From (usft)	Depth To (usft)	Survey (Wellbore)	Tool Name	Remarks	
1	0.00	20,750.38 Prelim 1 (OH)	MWD+HRGM+MS	MWD + HRGM + Multi-Station	

Plan Sections										
Measured Depth (usft)	Inclination (°)	Azimuth (°)	Vertical Depth (usft)	+N/-S (usft)	+E/-W (usft)	Dogleg Rate (°/100usft)	Build Rate (°/100usft)	Turn Rate (°/100usft)	TFO (°)	Target
0.00	0.00	0.00	0.00	0.00	0.00	0.00	0.00	0.00	0.00	
500.00	0.00	0.00	500.00	0.00	0.00	0.00	0.00	0.00	0.00	
869.53	7.39	175.35	868.50	-23.72	1.93	2.00	2.00	0.00	175.35	
6,657.93	7.39	175.35	6,608.82	-765.85	62.27	0.00	0.00	0.00	0.00	
7,650.38	89.96	90.31	7,233.18	-849.92	697.93	9.00	8.32	-8.57	-85.09	RU 808H POE
20,750.38	89.96	90.31	7,243.00	-920.98	13,797.73	0.00	0.00	0.00	0.00	RU 808H PBHL

SDT Planning Report

Database:	EDM 5000 Multi User Db	Local Co-ordinate Reference:	Well Rosa Unit 808H
Company:	Logos Operating LLC	TVD Reference:	6593+30 @ 6623.00usft (H&P 530)
Project:	Rio Arriba, NM (NAD83)	MD Reference:	6593+30 @ 6623.00usft (H&P 530)
Site:	Rosa Unit 38	North Reference:	True
Well:	Rosa Unit 808H	Survey Calculation Method:	Minimum Curvature
Wellbore:	OH		
Design:	Prelim 1		

Planned Survey									
Measured Depth (usft)	Inclination (°)	Azimuth (°)	Vertical Depth (usft)	+N-S (usft)	+E-W (usft)	Vertical Section (usft)	Dogleg Rate (°/100usft)	Build Rate (°/100usft)	Turn Rate (°/100usft)
0.00	0.00	0.00	0.00	0.00	0.00	0.00	0.00	0.00	0.00
100.00	0.00	0.00	100.00	0.00	0.00	0.00	0.00	0.00	0.00
200.00	0.00	0.00	200.00	0.00	0.00	0.00	0.00	0.00	0.00
300.00	0.00	0.00	300.00	0.00	0.00	0.00	0.00	0.00	0.00
400.00	0.00	0.00	400.00	0.00	0.00	0.00	0.00	0.00	0.00
500.00	0.00	0.00	500.00	0.00	0.00	0.00	0.00	0.00	0.00
Start Build 2.00									
600.00	2.00	175.35	599.98	-1.74	0.14	0.15	2.00	2.00	0.00
700.00	4.00	175.35	699.84	-6.96	0.57	0.60	2.00	2.00	0.00
800.00	6.00	175.35	799.45	-15.64	1.27	1.36	2.00	2.00	0.00
869.53	7.39	175.35	868.50	-23.72	1.93	2.06	2.00	2.00	0.00
Start 5788.40 hold at 869.53 MD									
900.00	7.39	175.35	898.72	-27.63	2.25	2.40	0.00	0.00	0.00
1,000.00	7.39	175.35	997.89	-40.45	3.29	3.51	0.00	0.00	0.00
1,100.00	7.39	175.35	1,097.06	-53.27	4.33	4.62	0.00	0.00	0.00
1,200.00	7.39	175.35	1,196.23	-66.09	5.37	5.73	0.00	0.00	0.00
1,300.00	7.39	175.35	1,295.40	-78.91	6.42	6.84	0.00	0.00	0.00
1,400.00	7.39	175.35	1,394.57	-91.73	7.46	7.95	0.00	0.00	0.00
1,500.00	7.39	175.35	1,493.74	-104.55	8.50	9.07	0.00	0.00	0.00
1,600.00	7.39	175.35	1,592.91	-117.37	9.54	10.18	0.00	0.00	0.00
1,700.00	7.39	175.35	1,692.08	-130.20	10.59	11.29	0.00	0.00	0.00
1,800.00	7.39	175.35	1,791.25	-143.02	11.63	12.40	0.00	0.00	0.00
1,900.00	7.39	175.35	1,890.42	-155.84	12.67	13.51	0.00	0.00	0.00
2,000.00	7.39	175.35	1,989.58	-168.66	13.71	14.62	0.00	0.00	0.00
2,100.00	7.39	175.35	2,088.75	-181.48	14.75	15.74	0.00	0.00	0.00
2,200.00	7.39	175.35	2,187.92	-194.30	15.80	16.85	0.00	0.00	0.00
2,300.00	7.39	175.35	2,287.09	-207.12	16.84	17.96	0.00	0.00	0.00
2,400.00	7.39	175.35	2,386.26	-219.94	17.88	19.07	0.00	0.00	0.00
2,500.00	7.39	175.35	2,485.43	-232.76	18.92	20.18	0.00	0.00	0.00
2,600.00	7.39	175.35	2,584.60	-245.58	19.97	21.30	0.00	0.00	0.00
2,700.00	7.39	175.35	2,683.77	-258.40	21.01	22.41	0.00	0.00	0.00
2,800.00	7.39	175.35	2,782.94	-271.22	22.05	23.52	0.00	0.00	0.00
2,851.49	7.39	175.35	2,834.00	-277.83	22.59	24.09	0.00	0.00	0.00
Ojo Alamo									
2,900.00	7.39	175.35	2,882.11	-284.05	23.09	24.63	0.00	0.00	0.00
2,975.52	7.39	175.35	2,957.00	-293.73	23.88	25.47	0.00	0.00	0.00
Kirtland									
3,000.00	7.39	175.35	2,981.28	-296.87	24.14	25.74	0.00	0.00	0.00
3,100.00	7.39	175.35	3,080.45	-309.69	25.18	26.85	0.00	0.00	0.00
3,200.00	7.39	175.35	3,179.62	-322.51	26.22	27.97	0.00	0.00	0.00
3,253.83	7.39	175.35	3,233.00	-329.41	26.78	28.56	0.00	0.00	0.00
Fruitland									
3,300.00	7.39	175.35	3,278.78	-335.33	27.26	29.08	0.00	0.00	0.00
3,352.65	7.39	175.35	3,331.00	-342.08	27.81	29.66	0.00	0.00	0.00
Top of Coals									
3,400.00	7.39	175.35	3,377.95	-348.15	28.31	30.19	0.00	0.00	0.00
3,482.73	7.39	175.35	3,460.00	-358.76	29.17	31.11	0.00	0.00	0.00
Base of Coals									
3,500.00	7.39	175.35	3,477.12	-360.97	29.35	31.30	0.00	0.00	0.00
3,600.00	7.39	175.35	3,576.29	-373.79	30.39	32.41	0.00	0.00	0.00
3,700.00	7.39	175.35	3,675.46	-386.61	31.43	33.52	0.00	0.00	0.00
3,708.61	7.39	175.35	3,684.00	-387.72	31.52	33.62	0.00	0.00	0.00
Pictured Cliffs									

SDT
Planning Report

Database:	EDM 5000 Multi User Db	Local Co-ordinate Reference:	Well Rosa Unit 808H
Company:	Logos Operating LLC	TVD Reference:	6593+30 @ 6623.00usft (H&P 530)
Project:	Rio Arriba, NM (NAD83)	MD Reference:	6593+30 @ 6623.00usft (H&P 530)
Site:	Rosa Unit 38	North Reference:	True
Well:	Rosa Unit 808H	Survey Calculation Method:	Minimum Curvature
Wellbore:	OH		
Design:	Prelim 1		

Planned Survey										
Measured Depth (usft)	Inclination (°)	Azimuth (°)	Vertical Depth (usft)	+N/-S (usft)	+E/-W (usft)	Vertical Section (usft)	Dogleg Rate (°/100usft)	Build Rate (°/100usft)	Turn Rate (°/100usft)	
3,800.00	7.39	175.35	3,774.63	-399.43	32.48	34.64	0.00	0.00	0.00	
3,808.44	7.39	175.35	3,783.00	-400.52	32.56	34.73	0.00	0.00	0.00	
Lewis										
3,900.00	7.39	175.35	3,873.80	-412.25	33.52	35.75	0.00	0.00	0.00	
4,000.00	7.39	175.35	3,972.97	-425.08	34.56	36.86	0.00	0.00	0.00	
4,100.00	7.39	175.35	4,072.14	-437.90	35.60	37.97	0.00	0.00	0.00	
4,200.00	7.39	175.35	4,171.31	-450.72	36.65	39.08	0.00	0.00	0.00	
4,300.00	7.39	175.35	4,270.48	-463.54	37.69	40.20	0.00	0.00	0.00	
4,400.00	7.39	175.35	4,369.65	-476.36	38.73	41.31	0.00	0.00	0.00	
4,500.00	7.39	175.35	4,468.82	-489.18	39.77	42.42	0.00	0.00	0.00	
4,600.00	7.39	175.35	4,567.99	-502.00	40.81	43.53	0.00	0.00	0.00	
4,700.00	7.39	175.35	4,667.15	-514.82	41.86	44.64	0.00	0.00	0.00	
4,800.00	7.39	175.35	4,766.32	-527.64	42.90	45.75	0.00	0.00	0.00	
4,900.00	7.39	175.35	4,865.49	-540.46	43.94	46.87	0.00	0.00	0.00	
4,930.76	7.39	175.35	4,896.00	-544.41	44.26	47.21	0.00	0.00	0.00	
Chacra										
5,000.00	7.39	175.35	4,964.66	-553.28	44.98	47.98	0.00	0.00	0.00	
5,100.00	7.39	175.35	5,063.83	-566.11	46.03	49.09	0.00	0.00	0.00	
5,200.00	7.39	175.35	5,163.00	-578.93	47.07	50.20	0.00	0.00	0.00	
5,300.00	7.39	175.35	5,262.17	-591.75	48.11	51.31	0.00	0.00	0.00	
5,400.00	7.39	175.35	5,361.34	-604.57	49.15	52.42	0.00	0.00	0.00	
5,458.14	7.39	175.35	5,419.00	-612.02	49.76	53.07	0.00	0.00	0.00	
Upper Cliff House										
5,500.00	7.39	175.35	5,460.51	-617.39	50.20	53.54	0.00	0.00	0.00	
5,600.00	7.39	175.35	5,559.68	-630.21	51.24	54.65	0.00	0.00	0.00	
5,700.00	7.39	175.35	5,658.85	-643.03	52.28	55.76	0.00	0.00	0.00	
5,745.53	7.39	175.35	5,704.00	-648.87	52.76	56.27	0.00	0.00	0.00	
Cliff House										
5,779.82	7.39	175.35	5,738.00	-653.26	53.11	56.65	0.00	0.00	0.00	
Menefee										
5,800.00	7.39	175.35	5,758.02	-655.85	53.32	56.87	0.00	0.00	0.00	
5,900.00	7.39	175.35	5,857.19	-668.67	54.37	57.98	0.00	0.00	0.00	
5,963.34	7.39	175.35	5,920.00	-676.79	55.03	58.69	0.00	0.00	0.00	
Point Lookout										
6,000.00	7.39	175.35	5,956.35	-681.49	55.41	59.09	0.00	0.00	0.00	
6,100.00	7.39	175.35	6,055.52	-694.31	56.45	60.21	0.00	0.00	0.00	
6,200.00	7.39	175.35	6,154.69	-707.13	57.49	61.32	0.00	0.00	0.00	
6,300.00	7.39	175.35	6,253.86	-719.96	58.54	62.43	0.00	0.00	0.00	
6,400.00	7.39	175.35	6,353.03	-732.78	59.58	63.54	0.00	0.00	0.00	
6,500.00	7.39	175.35	6,452.20	-745.60	60.62	64.65	0.00	0.00	0.00	
6,511.90	7.39	175.35	6,464.00	-747.12	60.74	64.79	0.00	0.00	0.00	
Mancos										
6,600.00	7.39	175.35	6,551.37	-758.42	61.66	65.77	0.00	0.00	0.00	
6,657.93	7.39	175.35	6,608.82	-765.85	62.27	66.41	0.00	0.00	0.00	
Start DLS 9.00 TFO -85.09										
6,700.00	8.58	149.19	6,650.49	-771.24	64.09	68.27	9.00	2.83	-62.18	
6,750.00	11.55	129.53	6,699.73	-777.63	69.87	74.07	9.00	5.93	-39.33	
6,800.00	15.28	118.54	6,748.37	-783.97	79.52	83.76	9.00	7.46	-21.98	
6,850.00	19.33	111.92	6,796.10	-790.21	92.99	97.27	9.00	8.11	-13.24	
6,900.00	23.54	107.56	6,842.63	-796.32	110.20	114.50	9.00	8.42	-8.72	
6,950.00	27.84	104.47	6,887.68	-802.25	131.03	135.37	9.00	8.59	-6.18	
7,000.00	32.19	102.15	6,930.97	-807.97	155.37	159.74	9.00	8.70	-4.63	
7,050.00	36.57	100.34	6,972.23	-813.45	183.05	187.45	9.00	8.76	-3.63	

SDT
Planning Report

Database:	EDM 5000 Multi User Db	Local Co-ordinate Reference:	Well Rosa Unit 808H
Company:	Logos Operating LLC	TVD Reference:	6593+30 @ 6623.00usft (H&P 530)
Project:	Rio Arriba, NM (NAD83)	MD Reference:	6593+30 @ 6623.00usft (H&P 530)
Site:	Rosa Unit 38	North Reference:	True
Well:	Rosa Unit 808H	Survey Calculation Method:	Minimum Curvature
Wellbore:	OH		
Design:	Prelim 1		

Planned Survey									
Measured Depth (usft)	Inclination (°)	Azimuth (°)	Vertical Depth (usft)	+N/-S (usft)	+E/-W (usft)	Vertical Section (usft)	Dogleg Rate (°/100usft)	Build Rate (°/100usft)	Turn Rate (°/100usft)
7,100.00	40.97	98.86	7,011.20	-818.65	213.92	218.35	9.00	8.81	-2.95
7,150.00	45.39	97.63	7,047.65	-823.54	247.78	252.23	9.00	8.84	-2.47
7,190.24	48.96	96.76	7,075.00	-827.23	277.06	281.53	9.00	8.86	-2.15
Black Top									
7,200.00	49.83	96.57	7,081.35	-828.09	284.41	288.89	9.00	8.87	-2.00
7,250.00	54.27	95.64	7,112.09	-832.27	323.61	328.10	9.00	8.88	-1.86
7,300.00	58.71	94.81	7,139.69	-836.06	365.11	369.63	9.00	8.89	-1.66
7,350.00	63.16	94.05	7,163.97	-839.43	408.68	413.21	9.00	8.90	-1.51
7,400.00	67.62	93.36	7,184.79	-842.36	454.03	458.58	9.00	8.91	-1.40
7,450.00	72.08	92.70	7,202.01	-844.84	500.89	505.45	9.00	8.92	-1.31
7,500.00	76.54	92.08	7,215.53	-846.84	548.97	553.55	9.00	8.92	-1.25
7,550.00	81.00	91.48	7,225.27	-848.36	597.98	602.56	9.00	8.92	-1.20
7,600.00	85.46	90.89	7,231.16	-849.39	647.61	652.19	9.00	8.92	-1.17
7,650.38	89.96	90.31	7,233.18	-849.92	697.93	702.52	9.00	8.93	-1.16
Start 13100.00 hold at 7650.38 MD									
7,700.00	89.96	90.31	7,233.21	-850.18	747.55	752.14	0.00	0.00	0.00
7,800.00	89.96	90.31	7,233.29	-850.73	847.55	852.14	0.00	0.00	0.00
7,900.00	89.96	90.31	7,233.36	-851.27	947.55	952.14	0.00	0.00	0.00
8,000.00	89.96	90.31	7,233.44	-851.81	1,047.54	1,052.14	0.00	0.00	0.00
8,100.00	89.96	90.31	7,233.51	-852.35	1,147.54	1,152.14	0.00	0.00	0.00
8,200.00	89.96	90.31	7,233.59	-852.90	1,247.54	1,252.14	0.00	0.00	0.00
8,300.00	89.96	90.31	7,233.66	-853.44	1,347.54	1,352.14	0.00	0.00	0.00
8,400.00	89.96	90.31	7,233.74	-853.98	1,447.54	1,452.14	0.00	0.00	0.00
8,500.00	89.96	90.31	7,233.81	-854.52	1,547.54	1,552.14	0.00	0.00	0.00
8,600.00	89.96	90.31	7,233.89	-855.07	1,647.54	1,652.14	0.00	0.00	0.00
8,700.00	89.96	90.31	7,233.96	-855.61	1,747.53	1,752.14	0.00	0.00	0.00
8,800.00	89.96	90.31	7,234.04	-856.15	1,847.53	1,852.14	0.00	0.00	0.00
8,900.00	89.96	90.31	7,234.11	-856.69	1,947.53	1,952.14	0.00	0.00	0.00
9,000.00	89.96	90.31	7,234.19	-857.24	2,047.53	2,052.14	0.00	0.00	0.00
9,100.00	89.96	90.31	7,234.26	-857.78	2,147.53	2,152.14	0.00	0.00	0.00
9,200.00	89.96	90.31	7,234.34	-858.32	2,247.53	2,252.14	0.00	0.00	0.00
9,300.00	89.96	90.31	7,234.41	-858.86	2,347.52	2,352.14	0.00	0.00	0.00
9,400.00	89.96	90.31	7,234.49	-859.41	2,447.52	2,452.14	0.00	0.00	0.00
9,500.00	89.96	90.31	7,234.56	-859.95	2,547.52	2,552.14	0.00	0.00	0.00
9,600.00	89.96	90.31	7,234.64	-860.49	2,647.52	2,652.14	0.00	0.00	0.00
9,700.00	89.96	90.31	7,234.71	-861.03	2,747.52	2,752.14	0.00	0.00	0.00
9,800.00	89.96	90.31	7,234.79	-861.58	2,847.52	2,852.14	0.00	0.00	0.00
9,900.00	89.96	90.31	7,234.86	-862.12	2,947.52	2,952.14	0.00	0.00	0.00
10,000.00	89.96	90.31	7,234.94	-862.66	3,047.51	3,052.14	0.00	0.00	0.00
10,100.00	89.96	90.31	7,235.01	-863.20	3,147.51	3,152.14	0.00	0.00	0.00
10,200.00	89.96	90.31	7,235.09	-863.75	3,247.51	3,252.14	0.00	0.00	0.00
10,300.00	89.96	90.31	7,235.16	-864.29	3,347.51	3,352.14	0.00	0.00	0.00
10,400.00	89.96	90.31	7,235.24	-864.83	3,447.51	3,452.14	0.00	0.00	0.00
10,500.00	89.96	90.31	7,235.31	-865.37	3,547.51	3,552.14	0.00	0.00	0.00
10,600.00	89.96	90.31	7,235.39	-865.92	3,647.51	3,652.14	0.00	0.00	0.00
10,700.00	89.96	90.31	7,235.46	-866.46	3,747.50	3,752.14	0.00	0.00	0.00
10,800.00	89.96	90.31	7,235.54	-867.00	3,847.50	3,852.14	0.00	0.00	0.00
10,900.00	89.96	90.31	7,235.61	-867.54	3,947.50	3,952.14	0.00	0.00	0.00
11,000.00	89.96	90.31	7,235.69	-868.09	4,047.50	4,052.14	0.00	0.00	0.00
11,100.00	89.96	90.31	7,235.76	-868.63	4,147.50	4,152.14	0.00	0.00	0.00
11,200.00	89.96	90.31	7,235.84	-869.17	4,247.50	4,252.14	0.00	0.00	0.00
11,300.00	89.96	90.31	7,235.91	-869.71	4,347.49	4,352.14	0.00	0.00	0.00
11,400.00	89.96	90.31	7,235.99	-870.26	4,447.49	4,452.14	0.00	0.00	0.00
11,500.00	89.96	90.31	7,236.06	-870.80	4,547.49	4,552.14	0.00	0.00	0.00

SDT
Planning Report

Database:	EDM 5000 Multi User Db	Local Co-ordinate Reference:	Well Rosa Unit 808H
Company:	Logos Operating LLC	TVD Reference:	6593+30 @ 6623.00usft (H&P 530)
Project:	Rio Arriba, NM (NAD83)	MD Reference:	6593+30 @ 6623.00usft (H&P 530)
Site:	Rosa Unit 38	North Reference:	True
Well:	Rosa Unit 808H	Survey Calculation Method:	Minimum Curvature
Wellbore:	OH		
Design:	Prelim 1		

Planned Survey									
Measured Depth (usft)	Inclination (°)	Azimuth (°)	Vertical Depth (usft)	+N/-S (usft)	+E/-W (usft)	Vertical Section (usft)	Dogleg Rate (°/100usft)	Build Rate (°/100usft)	Turn Rate (°/100usft)
11,600.00	89.96	90.31	7,236.14	-871.34	4,647.49	4,652.14	0.00	0.00	0.00
11,700.00	89.96	90.31	7,236.21	-871.88	4,747.49	4,752.14	0.00	0.00	0.00
11,800.00	89.96	90.31	7,236.29	-872.43	4,847.49	4,852.14	0.00	0.00	0.00
11,900.00	89.96	90.31	7,236.36	-872.97	4,947.49	4,952.14	0.00	0.00	0.00
12,000.00	89.96	90.31	7,236.44	-873.51	5,047.48	5,052.14	0.00	0.00	0.00
12,100.00	89.96	90.31	7,236.51	-874.05	5,147.48	5,152.14	0.00	0.00	0.00
12,200.00	89.96	90.31	7,236.59	-874.60	5,247.48	5,252.14	0.00	0.00	0.00
12,300.00	89.96	90.31	7,236.66	-875.14	5,347.48	5,352.14	0.00	0.00	0.00
12,400.00	89.96	90.31	7,236.74	-875.68	5,447.48	5,452.14	0.00	0.00	0.00
12,500.00	89.96	90.31	7,236.81	-876.22	5,547.48	5,552.14	0.00	0.00	0.00
12,600.00	89.96	90.31	7,236.89	-876.76	5,647.48	5,652.14	0.00	0.00	0.00
12,700.00	89.96	90.31	7,236.96	-877.31	5,747.47	5,752.14	0.00	0.00	0.00
12,800.00	89.96	90.31	7,237.04	-877.85	5,847.47	5,852.14	0.00	0.00	0.00
12,900.00	89.96	90.31	7,237.11	-878.39	5,947.47	5,952.14	0.00	0.00	0.00
13,000.00	89.96	90.31	7,237.19	-878.93	6,047.47	6,052.14	0.00	0.00	0.00
13,100.00	89.96	90.31	7,237.26	-879.48	6,147.47	6,152.14	0.00	0.00	0.00
13,200.00	89.96	90.31	7,237.34	-880.02	6,247.47	6,252.14	0.00	0.00	0.00
13,300.00	89.96	90.31	7,237.41	-880.56	6,347.46	6,352.14	0.00	0.00	0.00
13,400.00	89.96	90.31	7,237.49	-881.10	6,447.46	6,452.14	0.00	0.00	0.00
13,500.00	89.96	90.31	7,237.56	-881.65	6,547.46	6,552.14	0.00	0.00	0.00
13,600.00	89.96	90.31	7,237.64	-882.19	6,647.46	6,652.14	0.00	0.00	0.00
13,700.00	89.96	90.31	7,237.71	-882.73	6,747.46	6,752.14	0.00	0.00	0.00
13,800.00	89.96	90.31	7,237.79	-883.27	6,847.46	6,852.14	0.00	0.00	0.00
13,900.00	89.96	90.31	7,237.86	-883.82	6,947.46	6,952.14	0.00	0.00	0.00
14,000.00	89.96	90.31	7,237.94	-884.36	7,047.45	7,052.14	0.00	0.00	0.00
14,100.00	89.96	90.31	7,238.01	-884.90	7,147.45	7,152.14	0.00	0.00	0.00
14,200.00	89.96	90.31	7,238.09	-885.44	7,247.45	7,252.14	0.00	0.00	0.00
14,300.00	89.96	90.31	7,238.16	-885.99	7,347.45	7,352.14	0.00	0.00	0.00
14,400.00	89.96	90.31	7,238.24	-886.53	7,447.45	7,452.14	0.00	0.00	0.00
14,500.00	89.96	90.31	7,238.31	-887.07	7,547.45	7,552.14	0.00	0.00	0.00
14,600.00	89.96	90.31	7,238.39	-887.61	7,647.45	7,652.14	0.00	0.00	0.00
14,700.00	89.96	90.31	7,238.46	-888.16	7,747.44	7,752.14	0.00	0.00	0.00
14,800.00	89.96	90.31	7,238.54	-888.70	7,847.44	7,852.14	0.00	0.00	0.00
14,900.00	89.96	90.31	7,238.61	-889.24	7,947.44	7,952.14	0.00	0.00	0.00
15,000.00	89.96	90.31	7,238.69	-889.78	8,047.44	8,052.14	0.00	0.00	0.00
15,100.00	89.96	90.31	7,238.76	-890.33	8,147.44	8,152.14	0.00	0.00	0.00
15,200.00	89.96	90.31	7,238.84	-890.87	8,247.44	8,252.14	0.00	0.00	0.00
15,300.00	89.96	90.31	7,238.91	-891.41	8,347.43	8,352.14	0.00	0.00	0.00
15,400.00	89.96	90.31	7,238.99	-891.95	8,447.43	8,452.14	0.00	0.00	0.00
15,500.00	89.96	90.31	7,239.06	-892.50	8,547.43	8,552.14	0.00	0.00	0.00
15,600.00	89.96	90.31	7,239.14	-893.04	8,647.43	8,652.14	0.00	0.00	0.00
15,700.00	89.96	90.31	7,239.21	-893.58	8,747.43	8,752.14	0.00	0.00	0.00
15,800.00	89.96	90.31	7,239.29	-894.12	8,847.43	8,852.14	0.00	0.00	0.00
15,900.00	89.96	90.31	7,239.36	-894.67	8,947.43	8,952.14	0.00	0.00	0.00
16,000.00	89.96	90.31	7,239.44	-895.21	9,047.42	9,052.14	0.00	0.00	0.00
16,100.00	89.96	90.31	7,239.51	-895.75	9,147.42	9,152.14	0.00	0.00	0.00
16,200.00	89.96	90.31	7,239.59	-896.29	9,247.42	9,252.14	0.00	0.00	0.00
16,300.00	89.96	90.31	7,239.66	-896.84	9,347.42	9,352.14	0.00	0.00	0.00
16,400.00	89.96	90.31	7,239.74	-897.38	9,447.42	9,452.14	0.00	0.00	0.00
16,500.00	89.96	90.31	7,239.81	-897.92	9,547.42	9,552.14	0.00	0.00	0.00
16,600.00	89.96	90.31	7,239.89	-898.46	9,647.42	9,652.14	0.00	0.00	0.00
16,700.00	89.96	90.31	7,239.96	-899.01	9,747.41	9,752.14	0.00	0.00	0.00
16,800.00	89.96	90.31	7,240.04	-899.55	9,847.41	9,852.14	0.00	0.00	0.00
16,900.00	89.96	90.31	7,240.11	-900.09	9,947.41	9,952.14	0.00	0.00	0.00

SDT
Planning Report

Database:	EDM 5000 Multi User Db	Local Co-ordinate Reference:	Well Rosa Unit 808H
Company:	Logos Operating LLC	TVD Reference:	6593+30 @ 6623.00usft (H&P 530)
Project:	Rio Arriba, NM (NAD83)	MD Reference:	6593+30 @ 6623.00usft (H&P 530)
Site:	Rosa Unit 38	North Reference:	True
Well:	Rosa Unit 808H	Survey Calculation Method:	Minimum Curvature
Wellbore:	OH		
Design:	Prelim 1		

Planned Survey									
Measured Depth (usft)	Inclination (°)	Azimuth (°)	Vertical Depth (usft)	+N/-S (usft)	+E/-W (usft)	Vertical Section (usft)	Dogleg Rate (°/100usft)	Build Rate (°/100usft)	Turn Rate (°/100usft)
17,000.00	89.96	90.31	7,240.19	-900.63	10,047.41	10,052.14	0.00	0.00	0.00
17,100.00	89.96	90.31	7,240.26	-901.18	10,147.41	10,152.14	0.00	0.00	0.00
17,200.00	89.96	90.31	7,240.34	-901.72	10,247.41	10,252.14	0.00	0.00	0.00
17,300.00	89.96	90.31	7,240.41	-902.26	10,347.40	10,352.14	0.00	0.00	0.00
17,400.00	89.96	90.31	7,240.49	-902.80	10,447.40	10,452.14	0.00	0.00	0.00
17,500.00	89.96	90.31	7,240.56	-903.34	10,547.40	10,552.14	0.00	0.00	0.00
17,600.00	89.96	90.31	7,240.64	-903.89	10,647.40	10,652.13	0.00	0.00	0.00
17,700.00	89.96	90.31	7,240.71	-904.43	10,747.40	10,752.13	0.00	0.00	0.00
17,800.00	89.96	90.31	7,240.79	-904.97	10,847.40	10,852.13	0.00	0.00	0.00
17,900.00	89.96	90.31	7,240.86	-905.51	10,947.40	10,952.13	0.00	0.00	0.00
18,000.00	89.96	90.31	7,240.94	-906.06	11,047.39	11,052.13	0.00	0.00	0.00
18,100.00	89.96	90.31	7,241.01	-906.60	11,147.39	11,152.13	0.00	0.00	0.00
18,200.00	89.96	90.31	7,241.09	-907.14	11,247.39	11,252.13	0.00	0.00	0.00
18,300.00	89.96	90.31	7,241.16	-907.68	11,347.39	11,352.13	0.00	0.00	0.00
18,400.00	89.96	90.31	7,241.24	-908.23	11,447.39	11,452.13	0.00	0.00	0.00
18,500.00	89.96	90.31	7,241.31	-908.77	11,547.39	11,552.13	0.00	0.00	0.00
18,600.00	89.96	90.31	7,241.39	-909.31	11,647.39	11,652.13	0.00	0.00	0.00
18,700.00	89.96	90.31	7,241.46	-909.85	11,747.38	11,752.13	0.00	0.00	0.00
18,800.00	89.96	90.31	7,241.54	-910.40	11,847.38	11,852.13	0.00	0.00	0.00
18,900.00	89.96	90.31	7,241.61	-910.94	11,947.38	11,952.13	0.00	0.00	0.00
19,000.00	89.96	90.31	7,241.69	-911.48	12,047.38	12,052.13	0.00	0.00	0.00
19,100.00	89.96	90.31	7,241.76	-912.02	12,147.38	12,152.13	0.00	0.00	0.00
19,200.00	89.96	90.31	7,241.84	-912.57	12,247.38	12,252.13	0.00	0.00	0.00
19,300.00	89.96	90.31	7,241.91	-913.11	12,347.37	12,352.13	0.00	0.00	0.00
19,400.00	89.96	90.31	7,241.99	-913.65	12,447.37	12,452.13	0.00	0.00	0.00
19,500.00	89.96	90.31	7,242.06	-914.19	12,547.37	12,552.13	0.00	0.00	0.00
19,600.00	89.96	90.31	7,242.14	-914.74	12,647.37	12,652.13	0.00	0.00	0.00
19,700.00	89.96	90.31	7,242.21	-915.28	12,747.37	12,752.13	0.00	0.00	0.00
19,800.00	89.96	90.31	7,242.29	-915.82	12,847.37	12,852.13	0.00	0.00	0.00
19,900.00	89.96	90.31	7,242.36	-916.36	12,947.37	12,952.13	0.00	0.00	0.00
20,000.00	89.96	90.31	7,242.44	-916.91	13,047.36	13,052.13	0.00	0.00	0.00
20,100.00	89.96	90.31	7,242.51	-917.45	13,147.36	13,152.13	0.00	0.00	0.00
20,200.00	89.96	90.31	7,242.59	-917.99	13,247.36	13,252.13	0.00	0.00	0.00
20,300.00	89.96	90.31	7,242.66	-918.53	13,347.36	13,352.13	0.00	0.00	0.00
20,400.00	89.96	90.31	7,242.74	-919.08	13,447.36	13,452.13	0.00	0.00	0.00
20,500.00	89.96	90.31	7,242.81	-919.62	13,547.36	13,552.13	0.00	0.00	0.00
20,600.00	89.96	90.31	7,242.89	-920.16	13,647.36	13,652.13	0.00	0.00	0.00
20,700.00	89.96	90.31	7,242.96	-920.70	13,747.35	13,752.13	0.00	0.00	0.00
20,750.38	89.96	90.31	7,243.00	-920.98	13,797.73	13,802.51	0.00	0.00	0.00
TD at 20750.38									

SDT Planning Report

Database:	EDM 5000 Multi User Db	Local Co-ordinate Reference:	Well Rosa Unit 808H
Company:	Logos Operating LLC	TVD Reference:	6593+30 @ 6623.00usft (H&P 530)
Project:	Rio Arriba, NM (NAD83)	MD Reference:	6593+30 @ 6623.00usft (H&P 530)
Site:	Rosa Unit 38	North Reference:	True
Well:	Rosa Unit 808H	Survey Calculation Method:	Minimum Curvature
Wellbore:	OH		
Design:	Prelim 1		

Design Targets									
Target Name	Dip Angle	Dip Dir.	TVD	+N/-S	+E/-W	Northing	Easting	Latitude	Longitude
- hit/miss target	(°)	(°)	(usft)	(usft)	(usft)	(usft)	(usft)		
- Shape									
RU 808H SHL - plan hits target center - Point	0.00	0.00	0.00	0.00	0.00	2,141,092.74	2,874,216.67	36.882853	-107.316590
RU 808H KOP - plan hits target center - Point	0.00	0.00	6,608.82	-765.85	62.27	2,140,327.25	2,874,283.08	36.880750	-107.316377
RU 808H POE - plan hits target center - Point	0.00	0.00	7,233.18	-849.92	697.93	2,140,246.62	2,874,919.19	36.880519	-107.314204
RU 808H PBHL - plan hits target center - Point	0.00	0.00	7,243.00	-920.98	13,797.73	2,140,246.47	2,888,019.19	36.880314	-107.269414

Formations						
Measured Depth	Vertical Depth	Name	Lithology	Dip	Dip Direction	
(usft)	(usft)			(°)	(°)	
2,851.49	2,834.00	Ojo Alamo				
2,975.52	2,957.00	Kirtland				
3,253.83	3,233.00	Fruitland				
3,352.65	3,331.00	Top of Coals				
3,482.73	3,460.00	Base of Coals				
3,708.61	3,684.00	Pictured Cliffs				
3,808.44	3,783.00	Lewis				
4,930.76	4,896.00	Chacra				
5,458.14	5,419.00	Upper Cliff House				
5,745.53	5,704.00	Cliff House				
5,779.82	5,738.00	Menefee				
5,963.34	5,920.00	Point Lookout				
6,511.90	6,464.00	Mancos				
7,190.24	7,075.00	Black Top				

Plan Annotations					
Measured Depth	Vertical Depth	Local Coordinates		Comment	
(usft)	(usft)	+N/-S	+E/-W		
		(usft)	(usft)		
500.00	500.00	0.00	0.00	Start Build 2.00	
869.53	868.50	-23.72	1.93	Start 5788.40 hold at 869.53 MD	
6,657.93	6,608.82	-765.85	62.27	Start DLS 9.00 TFO -85.09	
7,650.38	7,233.18	-849.92	697.93	Start 13100.00 hold at 7650.38 MD	
20,750.38	7,243.00	-920.98	13,797.73	TD at 20750.38	

Sante Fe Main Office
Phone: (505) 476-3441

General Information
Phone: (505) 629-6116

Online Phone Directory
<https://www.emnrd.nm.gov/ocd/contact-us>

State of New Mexico
Energy, Minerals and Natural Resources
Oil Conservation Division
1220 S. St Francis Dr.
Santa Fe, NM 87505

ACKNOWLEDGMENTS

Action 562328

ACKNOWLEDGMENTS

Operator: LOGOS OPERATING, LLC 2010 Afton Place Farmington, NM 87401	OGRID: 289408
	Action Number: 562328
	Action Type: [C-101] BLM - Federal/Indian Land Lease (Form 3160-3)

ACKNOWLEDGMENTS

<input checked="" type="checkbox"/>	I hereby certify that no additives containing PFAS chemicals will be added to the completion or recompletion of this well.
-------------------------------------	--

Sante Fe Main Office
Phone: (505) 476-3441

General Information
Phone: (505) 629-6116

Online Phone Directory
<https://www.emnrd.nm.gov/ocd/contact-us>

State of New Mexico
Energy, Minerals and Natural Resources
Oil Conservation Division
1220 S. St Francis Dr.
Santa Fe, NM 87505

CONDITIONS

Action 562328

CONDITIONS

Operator: LOGOS OPERATING, LLC 2010 Afton Place Farmington, NM 87401	OGRID: 289408
	Action Number: 562328
	Action Type: [C-101] BLM - Federal/Indian Land Lease (Form 3160-3)

CONDITIONS

Created By	Condition	Condition Date
etta trujillo	Cement is required to circulate on both surface and intermediate1 strings of casing.	3/12/2026
etta trujillo	If cement does not circulate on any string, a Cement Bond Log (CBL) is required for that string of casing.	3/12/2026
ward.rikala	Notify the OCD 24 hours prior to casing & cement.	4/9/2026
ward.rikala	File As Drilled C-102 and a directional Survey with C-104 completion packet.	4/9/2026
ward.rikala	Once the well is spud, to prevent ground water contamination through whole or partial conduits from the surface, the operator shall drill without interruption through the fresh water zone or zones and shall immediately set in cement the water protection string.	4/9/2026
ward.rikala	Oil base muds are not to be used until fresh water zones are cased and cemented providing isolation from the oil or diesel. This includes synthetic oils. Oil based mud, drilling fluids and solids must be contained in a steel closed loop system.	4/9/2026
ward.rikala	If the method of isolation was not by circulation, a CBL must be performed; if strata isolation is not achieved, then remediation will be required before further operations.	4/9/2026
ward.rikala	If a DV tool is utilized during the casing cementing operations, the following COA applies: 1- Once the DV tool is opened and circulation is established, it needs to be noted if cement is circulated off of the top of the DV tool and how much. 2- If cement is not circulated off of the top of the DV tool, then a CBL will be required. Depending upon the results of the CBL, remedial action may be required prior to drilling operations continuing.	4/9/2026