

Form 3160-3
(October 2024)

FORM APPROVED
OMB No. 1004-0220
Expires: October 31, 2027

UNITED STATES
DEPARTMENT OF THE INTERIOR
BUREAU OF LAND MANAGEMENT
APPLICATION FOR PERMIT TO DRILL OR REENTER

1a. Type of work: <input type="checkbox"/> DRILL <input type="checkbox"/> REENTER 1b. Type of Well: <input type="checkbox"/> Oil Well <input type="checkbox"/> Gas Well <input type="checkbox"/> Other 1c. Type of Completion: <input type="checkbox"/> Hydraulic Fracturing <input type="checkbox"/> Single Zone <input type="checkbox"/> Multiple Zone		5. Lease Serial No. 6. If Indian, Allottee or Tribe Name 7. If Unit or CA Agreement, Name and No. 8. Lease Name and Well No.
2. Name of Operator		9. API Well No. <b style="color: red; font-size: 1.2em;">30-015-58051
3a. Address	3b. Phone No. (include area code)	10. Field and Pool, or Exploratory
4. Location of Well (Report location clearly and in accordance with any State requirements. *) At surface At proposed prod. zone		11. Sec., T. R. M. or Blk. and Survey or Area
14. Distance in miles and direction from nearest town or post office*		12. County or Parish 13. State
15. Distance from proposed* location to nearest property or lease line, ft. (Also to nearest drig. unit line, if any)	16. No of acres in lease	17. Spacing Unit dedicated to this well
18. Distance from proposed location* to nearest well, drilling, completed, applied for, on this lease, ft.	19. Proposed Depth	20. BLM/BIA Bond No. in file
21. Elevations (Show whether DF, KDB, RT, GL, etc.)	22. Approximate date work will start*	23. Estimated duration
24. Attachments		

The following, completed in accordance with the requirements of Onshore Oil and Gas Order No. 1, and the Hydraulic Fracturing rule per 43 CFR 3162.3-3 (as applicable)

- | | |
|---|---|
| 1. Well plat certified by a registered surveyor.
2. A Drilling Plan.
3. A Surface Use Plan (if the location is on National Forest System Lands, the SUPO must be filed with the appropriate Forest Service Office). | 4. Bond to cover the operations unless covered by an existing bond on file (see Item 20 above).
5. Operator certification.
6. Such other site specific information and/or plans as may be requested by the BLM. |
|---|---|

25. Signature	Name (Printed/Typed)	Date
Title		
Approved by (Signature)		
Name (Printed/Typed)		Date
Title		Office

Application approval does not warrant or certify that the applicant holds legal or equitable title to those rights in the subject lease which would entitle the applicant to conduct operations thereon.
 Conditions of approval, if any, are attached.

Title 18 U.S.C. Section 1001 and Title 43 U.S.C. Section 1212, make it a crime for any person knowingly and willfully to make to any department or agency of the United States any false, fictitious or fraudulent statements or representations as to any matter within its jurisdiction.



(Continued on page 2)

*(Instructions on page 2)

INSTRUCTIONS

GENERAL: This form is designed for submitting proposals to perform certain well operations, as indicated on Federal and Indian lands and leases for action by appropriate Federal agencies, pursuant to applicable Federal laws and regulations. Any necessary special instructions concerning the use of this form and the number of copies to be submitted, particularly with regard to local, area, or regional procedures and practices, either are shown below or will be issued by, or may be obtained from local Federal offices.

ITEM I: If the proposal is to redrill to the same reservoir at a different subsurface location or to a new reservoir, use this form with appropriate notations. Consult applicable Federal regulations concerning subsequent work proposals or reports on the well.

ITEM 4: Locations on Federal or Indian land should be described in accordance with Federal requirements. Consult local Federal offices for specific instructions.

ITEM 14: Needed only when location of well cannot readily be found by road from the land or lease description. A plat, or plats, separate or on the reverse side, showing the roads to, and the surveyed location of, the well, and any other required information, should be furnished when required by Federal agency offices.

ITEMS 15 AND 18: If well is to be, or has been directionally drilled, give distances for subsurface location of hole in any present or objective productive zone.

ITEM 22: Consult applicable Federal regulations, or appropriate officials, concerning approval of the proposal before operations are started.

ITEM 24: If the proposal will involve hydraulic fracturing operations, you must comply with 43 CFR 3162.3-3, including providing information about the protection of usable water. Operators should provide the best available information about all formations containing water and their depths. This information could include data and interpretation of resistivity logs run on nearby wells. Information may also be obtained from state or tribal regulatory agencies and from local BLM offices.

NOTICES

The Privacy Act of 1974 and regulation in 43 CFR 2.48(d) provide that you be furnished the following information in connection with information required by this application.

AUTHORITY: 30 U.S.C. 181 et seq., 25 U.S.C. 396; 43 CFR 3160

PRINCIPAL PURPOSES: The information will be used to: (1) process and evaluate your application for a permit to drill a new oil, gas, or service well or to reenter a plugged and abandoned well; and (2) document, for administrative use, information for the management, disposal and use of National Resource Lands and resources including (a) analyzing your proposal to discover and extract the Federal or Indian resources encountered; (b) reviewing procedures and equipment and the projected impact on the land involved; and (c) evaluating the effects of the proposed operation on the surface and subsurface water and other environmental impacts.

ROUTINE USE: Information from the record and/or the record will be transferred to appropriate Federal, State, and local or foreign agencies, when relevant to civil, criminal or regulatory investigations or prosecution, in connection with congressional inquiries and for regulatory responsibilities.

EFFECT OF NOT PROVIDING INFORMATION: Filing of this application and disclosure of the information is mandatory only if you elect to initiate a drilling or reentry operation on an oil and gas lease.

The Paperwork Reduction Act of 1995 requires us to inform you that:

The BLM connects this information to a new evaluation of the technical, safety, and environmental factors involved with drilling for oil and/or gas on Federal and Indian oil and gas leases. This information will be used to analyze and approve applications. Response to this request is mandatory only if the operator elects to initiate drilling or reentry operations on an oil and gas lease. The BLM would like you to know that you do not have to respond to this or any other Federal agency-sponsored information collection unless it displays a currently valid OMB control number.

BURDEN HOURS STATEMENT: Public reporting burden for this form is estimated to average 8 hours per response, including the time for reviewing instructions, gathering and maintaining data, and completing and reviewing the form. Direct comments regarding the burden estimate or any other aspect of this form to U.S. Department of the Interior, Bureau of Land Management (1004-0137), Bureau Information Connection Clearance Officer (WO-630), 1849 C Street, N.W., Mail Stop 401 LS, Washington, D.C. 20240.

Additional Operator Remarks

Location of Well

0. SHL: NENW / 125 FNL / 1862 FWL / TWSP: 23S / RANGE: 31E / SECTION: 34 / LAT: 32.2678411 / LONG: -103.7681834 (TVD: 0 feet, MD: 0 feet)

PPP: NENW / 100 FNL / 1341 FWL / TWSP: 23S / RANGE: 31E / SECTION: 34 / LAT: 32.2679095 / LONG: -103.7698679 (TVD: 12600 feet, MD: 12970 feet)

BHL: SESW / 20 FSL / 1341 FWL / TWSP: 24S / RANGE: 31E / SECTION: 3 / LAT: 32.2391924 / LONG: -103.7698945 (TVD: 12600 feet, MD: 22894 feet)

BLM Point of Contact

Name: TENILLE C MOLINA

Title: Land Law Examiner

Phone: (575) 234-2224

Email: TCMOLINA@BLM.GOV

<p>C-102</p> <p>Submit Electronically Via OCD Permitting</p>	<p>State of New Mexico Energy, Minerals, & Natural Resources Department OIL CONSERVATION DIVISION</p>	<p>Revised July 9, 2024 PAGE 1 OF 2</p>
		<p>Submittal Type: <input checked="" type="checkbox"/> Initial Submittal <input type="checkbox"/> Amended Report <input type="checkbox"/> As Drilled</p>

WELL LOCATION INFORMATION

API Number 30-015- 58051	Pool Code 98220	Pool Name PURPLE SAGE; WOLFCAMP (GAS)
Property Code 322245	Property Name PLATINUM MDP1 34_3 FED COM	Well Number 52H
OGRID No. 16696	Operator Name OXY USA INC.	Ground Level Elevation 3420'
Surface Owner: <input type="checkbox"/> State <input type="checkbox"/> Fee <input type="checkbox"/> Tribal <input checked="" type="checkbox"/> Federal		Mineral Owner: <input type="checkbox"/> State <input type="checkbox"/> Fee <input type="checkbox"/> Tribal <input checked="" type="checkbox"/> Federal

Surface Location

UL	Section	Township	Range	Lot	Ft. from N/S	Ft. from E/W	Latitude (NAD83)	Longitude (NAD83)	County
C	34	23S	31E		125' FNL	1862' FWL	32.26784118	-103.76818347	EDDY

Bottom Hole Location

UL	Section	Township	Range	Lot	Ft. from N/S	Ft. from E/W	Latitude (NAD83)	Longitude (NAD83)	County
N	03	24S	31E		20' FSL	1341' FWL	32.23919241	-103.76989456	EDDY

Dedicated Acres 320.33	Infill or Defining Well Infill	Defining Well API 30-015-46046	Overlapping Spacing Unit (Y/N) N	Consolidation Code N/A
Order Numbers: N/A			Well setbacks are under Common Ownership: <input type="checkbox"/> Yes <input type="checkbox"/> No	

Kick Off Point (KOP)

UL	Section	Township	Range	Lot	Ft. from N/S	Ft. from E/W	Latitude (NAD83)	Longitude (NAD83)	County
C	34	23S	31E		50' FNL	1341' FWL	32.26804700	-103.76986797	EDDY

First Take Point (FTP)

UL	Section	Township	Range	Lot	Ft. from N/S	Ft. from E/W	Latitude (NAD83)	Longitude (NAD83)	County
C	34	23S	31E		100' FNL	1341' FWL	32.26790956	-103.76986792	EDDY

Last Take Point (LTP)

UL	Section	Township	Range	Lot	Ft. from N/S	Ft. from E/W	Latitude (NAD83)	Longitude (NAD83)	County
N	03	24S	31E		100' FSL	1341' FWL	32.23941232	-103.76989409	EDDY

Unitized Area or Area of Uniform Interest N/A	Spacing Unit Type: <input checked="" type="checkbox"/> Horizontal <input type="checkbox"/> Vertical	Ground Floor Elevation 3420'
---	---	--

<p>OPERATOR CERTIFICATIONS</p> <p><i>I hereby certify that the information contained herein is true and complete to the best of my knowledge and belief, and, if the well is a vertical or directional well, that this organization either owns a working interest or unleased mineral interest in the land including the proposed bottom hole location or has a right to drill this well at this location pursuant to a contract with an owner of a working interest or unleased mineral interest, or to a voluntary pooling agreement or a compulsory pooling order heretofore entered by the division.</i></p> <p><i>If this well is a horizontal well, I further certify that this organization has received the consent of at least one lessee or owner of a working interest or unleased mineral interest in each tract (in the target pool or formation) in which any part of the well's completed interval will be located or obtained a compulsory pooling order from the division.</i></p> <p><u>Roni Mathew</u> <u>06/24/2025</u> Signature Date</p> <p>RONI MATHEW Printed Name</p> <p><u>roni_mathew@oxy.com</u> Email Address</p>	<p>SURVEYOR CERTIFICATIONS</p> <p><i>I hereby certify that the well location shown on this plat was plotted from field notes of actual surveys made by me or under my supervision, and that the same is true and correct to the best of my belief.</i></p> <div style="text-align: center;">  </div> <p>Signature and Seal of Professional Surveyor</p> <table border="1" style="width:100%; border-collapse: collapse;"> <tr> <td>Certificate Number 21653</td> <td>Date of Survey FEBRUARY 26, 2025</td> </tr> </table>	Certificate Number 21653	Date of Survey FEBRUARY 26, 2025
Certificate Number 21653	Date of Survey FEBRUARY 26, 2025		

SHL (NAD83) X:716017.25' / Y:461633.61' LAT:32.26784118 / LON:-103.76818347
SHL (NAD27) X:674833.67' / Y:461574.31' LAT:32.26771807 / LON:-103.76769842

KOP (NAD83) X:715496.20' / Y:461705.74' LAT:32.26804700 / LON:-103.76986797
KOP (NAD27) X:674312.62' / Y:461646.45' LAT:32.26792389 / LON:-103.76938286

FTP (NAD83) X:715496.47' / Y:461655.74' LAT:32.26790956 / LON:-103.76986792
FTP (NAD27) X:674312.90' / Y:461596.45' LAT:32.26778645 / LON:-103.76938282

PPP-1 (NAD83) X:715519.63' / Y:456473.63' LAT:32.25366486 / LON:-103.76988102
PPP-1 (NAD27) X:674335.89' / Y:456414.48' LAT:32.25354168 / LON:-103.76939649

LTP (NAD83) X:715542.79' / Y:451288.68' LAT:32.23941232 / LON:-103.76989409
LTP (NAD27) X:674358.88' / Y:451229.65' LAT:32.23928902 / LON:-103.76941023

BHL (NAD83) X:715543.07' / Y:451208.68' LAT:32.23919241 / LON:-103.76989456
BHL (NAD27) X:674359.15' / Y:451149.65' LAT:32.23906911 / LON:-103.76941070

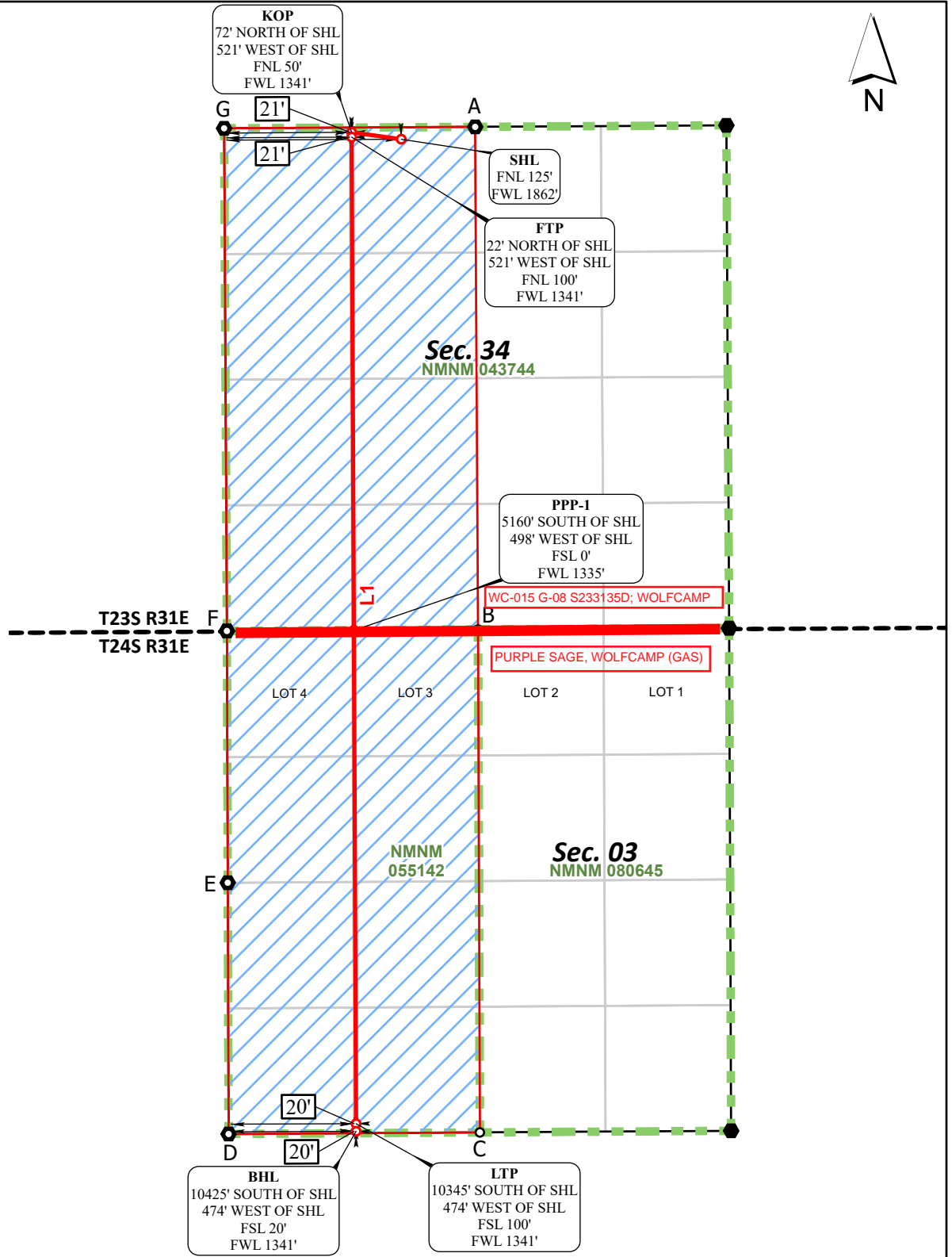

CORNER COORDINATES NAD 83, SPCS NM EAST	
A - X: 716794.61' / Y:461763.23'	
B - X: 716824.24' / Y:456480.96'	
C - X: 716843.83' / Y:451197.02'	
D - X: 714202.16' / Y:451180.09'	
E - X: 714193.02' / Y:453820.64'	
F - X: 714184.36' / Y:456466.14'	
G - X: 714154.94' / Y:461748.01'	

CORNER COORDINATES NAD 27, SPCS NM EAST	
A - X: 675611.03' / Y:461703.93'	
B - X: 675640.50' / Y:456421.80'	
C - X: 675659.90' / Y:451137.98'	
D - X: 673018.24' / Y:451121.06'	
E - X: 673009.20' / Y:453761.54'	
F - X: 673000.63' / Y:456406.98'	
G - X: 672971.37' / Y:461688.71'	

*FTP TO LTP LINE BEARINGS	
LINE	BEARING
L1	S 00°15'22" E ~ 10367.16'

*FTP TO LTP LEASE DISTANCES	
TRACT	DISTANCE
NMNM 043744	5182.16'
NMNM 055142	5185.00'
TOTAL	10367.16'

○ Drill Line Events
 ● Section Corners
 — Drill Line
 ↔ Dimension Lines
 - - - Federal Leases
 ▭ HSU
 ○ HSU Corners
 JOB No. OXY_0033_PT_14723
 All bearings and coordinates refer to New Mexico State Plane Coordinate System, East Zone, U.S. Survey Feet.
 REV 1 NDS 2/25/2025

Distances/areas relative to NAD 83 grid measurements. Combined Scale Factor: 0.99978064 and a Convergence Angle: 0.30307491°



<p>C-102</p> <p>Submit Electronically Via OCD Permitting</p>	<p>State of New Mexico Energy, Minerals, & Natural Resources Department OIL CONSERVATION DIVISION</p>	<p>Revised July 9, 2024 PAGE 1 OF 2</p>		
		<table border="1" style="width:100%; border-collapse: collapse;"> <tr> <td style="width:10%; border: none;">Submittal Type:</td> <td style="border: none;"> <input checked="" type="checkbox"/> Initial Submittal <input type="checkbox"/> Amended Report <input type="checkbox"/> As Drilled </td> </tr> </table>	Submittal Type:	<input checked="" type="checkbox"/> Initial Submittal <input type="checkbox"/> Amended Report <input type="checkbox"/> As Drilled
Submittal Type:	<input checked="" type="checkbox"/> Initial Submittal <input type="checkbox"/> Amended Report <input type="checkbox"/> As Drilled			

WELL LOCATION INFORMATION

API Number 30-015- 58051	Pool Code 98236	Pool Name WC-015 G-08 S233135D, WOLFCAMP
Property Code 322245	Property Name PLATINUM MDP1 34_3 FED COM	Well Number 52H
OGRID No. 16696	Operator Name OXY USA INC.	Ground Level Elevation 3420'
Surface Owner: <input type="checkbox"/> State <input type="checkbox"/> Fee <input type="checkbox"/> Tribal <input checked="" type="checkbox"/> Federal		Mineral Owner: <input type="checkbox"/> State <input type="checkbox"/> Fee <input type="checkbox"/> Tribal <input checked="" type="checkbox"/> Federal

Surface Location

UL	Section	Township	Range	Lot	Ft. from N/S	Ft. from E/W	Latitude (NAD83)	Longitude (NAD83)	County
C	34	23S	31E		125' FNL	1862' FWL	32.26784118	-103.76818347	EDDY

Bottom Hole Location

UL	Section	Township	Range	Lot	Ft. from N/S	Ft. from E/W	Latitude (NAD83)	Longitude (NAD83)	County
N	03	24S	31E		20' FSL	1341' FWL	32.23919241	-103.76989456	EDDY

Dedicated Acres 320	Infill or Defining Well Infill	Defining Well API 30-015-46046	Overlapping Spacing Unit (Y/N) N	Consolidation Code N/A
Order Numbers: N/A			Well setbacks are under Common Ownership: <input type="checkbox"/> Yes <input type="checkbox"/> No	

Kick Off Point (KOP)

UL	Section	Township	Range	Lot	Ft. from N/S	Ft. from E/W	Latitude (NAD83)	Longitude (NAD83)	County
C	34	23S	31E		50' FNL	1341' FWL	32.26804700	-103.76986797	EDDY

First Take Point (FTP)

UL	Section	Township	Range	Lot	Ft. from N/S	Ft. from E/W	Latitude (NAD83)	Longitude (NAD83)	County
C	34	23S	31E		100' FNL	1341' FWL	32.26790956	-103.76986792	EDDY

Last Take Point (LTP)

UL	Section	Township	Range	Lot	Ft. from N/S	Ft. from E/W	Latitude (NAD83)	Longitude (NAD83)	County
N	03	24S	31E		100' FSL	1341' FWL	32.23941232	-103.76989409	EDDY

Unitized Area or Area of Uniform Interest N/A	Spacing Unit Type: <input checked="" type="checkbox"/> Horizontal <input type="checkbox"/> Vertical	Ground Floor Elevation 3420'
---	---	--

<p>OPERATOR CERTIFICATIONS</p> <p><i>I hereby certify that the information contained herein is true and complete to the best of my knowledge and belief, and, if the well is a vertical or directional well, that this organization either owns a working interest or unleased mineral interest in the land including the proposed bottom hole location or has a right to drill this well at this location pursuant to a contract with an owner of a working interest or unleased mineral interest, or to a voluntary pooling agreement or a compulsory pooling order heretofore entered by the division.</i></p> <p><i>If this well is a horizontal well, I further certify that this organization has received the consent of at least one lessee or owner of a working interest or unleased mineral interest in each tract (in the target pool or formation) in which any part of the well's completed interval will be located or obtained a compulsory pooling order from the division.</i></p> <p><u>Roni Mathew</u> <u>06/24/2025</u> Signature Date</p> <p>RONI MATHEW Printed Name</p> <p><u>roni_mathew@oxy.com</u> Email Address</p>	<p>SURVEYOR CERTIFICATIONS</p> <p><i>I hereby certify that the well location shown on this plat was plotted from field notes of actual surveys made by me or under my supervision, and that the same is true and correct to the best of my belief.</i></p> <div style="text-align: center;">  </div> <p>Signature and Seal of Professional Surveyor</p> <table border="1" style="width:100%; border-collapse: collapse;"> <tr> <td style="width:50%;">Certificate Number 21653</td> <td style="width:50%;">Date of Survey FEBRUARY 26, 2025</td> </tr> </table>	Certificate Number 21653	Date of Survey FEBRUARY 26, 2025
Certificate Number 21653	Date of Survey FEBRUARY 26, 2025		

SHL (NAD83) X:716017.25' / Y:461633.61' LAT:32.26784118 / LON:-103.76818347
SHL (NAD27) X:674833.67' / Y:461574.31' LAT:32.26771807 / LON:-103.76769842

KOP (NAD83) X:715496.20' / Y:461705.74' LAT:32.26804700 / LON:-103.76986797
KOP (NAD27) X:674312.62' / Y:461646.45' LAT:32.26792389 / LON:-103.76938286

FTP (NAD83) X:715496.47' / Y:461655.74' LAT:32.26790956 / LON:-103.76986792
FTP (NAD27) X:674312.90' / Y:461596.45' LAT:32.26778645 / LON:-103.76938282

PPP-1 (NAD83) X:715519.63' / Y:456473.63' LAT:32.25366486 / LON:-103.76988102
PPP-1 (NAD27) X:674335.89' / Y:456414.48' LAT:32.25354168 / LON:-103.76939649

LTP (NAD83) X:715542.79' / Y:451288.68' LAT:32.23941232 / LON:-103.76989409
LTP (NAD27) X:674358.88' / Y:451229.65' LAT:32.23928902 / LON:-103.76941023

BHL (NAD83) X:715543.07' / Y:451208.68' LAT:32.23919241 / LON:-103.76989456
BHL (NAD27) X:674359.15' / Y:451149.65' LAT:32.23906911 / LON:-103.76941070

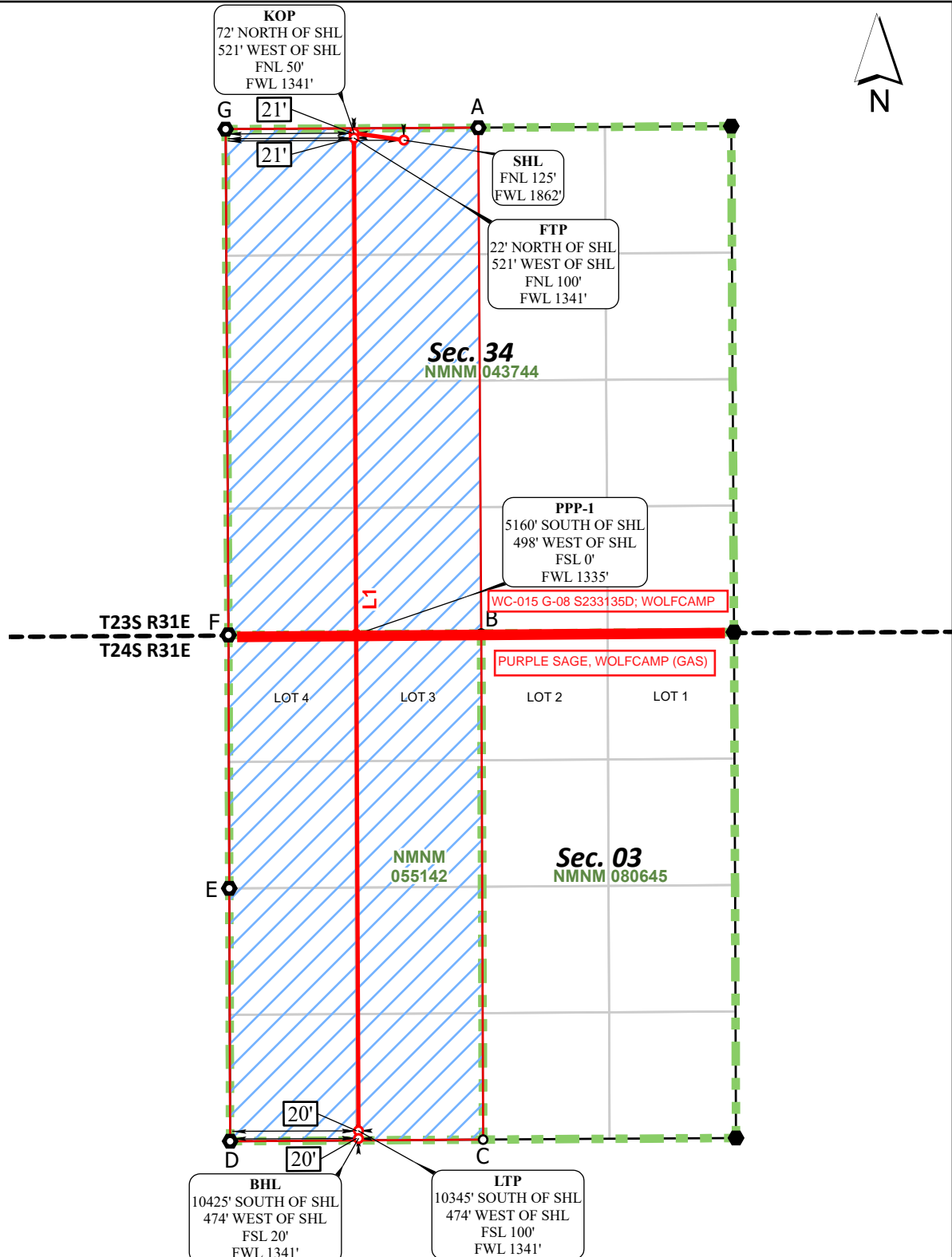

T23S R31E
T24S R31E

LOT 4	LOT 3	LOT 2	LOT 1
--------------	--------------	--------------	--------------

NMNM 043744	NMNM 055142	Sec. 03 NMNM 080645
--------------------	--------------------	----------------------------

WOLF CAMP	PURPLE SAGE, WOLF CAMP (GAS)
------------------	-------------------------------------

WOLF CAMP	PURPLE SAGE, WOLF CAMP (GAS)
------------------	-------------------------------------

WOLF CAMP	PURPLE SAGE, WOLF CAMP (GAS)
------------------	-------------------------------------

WOLF CAMP	PURPLE SAGE, WOLF CAMP (GAS)
------------------	-------------------------------------

WOLF CAMP	PURPLE SAGE, WOLF CAMP (GAS)
------------------	-------------------------------------

WOLF CAMP	PURPLE SAGE, WOLF CAMP (GAS)
------------------	-------------------------------------

WOLF CAMP	PURPLE SAGE, WOLF CAMP (GAS)
------------------	-------------------------------------

WOLF CAMP	PURPLE SAGE, WOLF CAMP (GAS)
------------------	-------------------------------------

WOLF CAMP	PURPLE SAGE, WOLF CAMP (GAS)
------------------	-------------------------------------

WOLF CAMP	PURPLE SAGE, WOLF CAMP (GAS)
------------------	-------------------------------------

WOLF CAMP	PURPLE SAGE, WOLF CAMP (GAS)
------------------	-------------------------------------

CORNER COORDINATES NAD 83, SPCS NM EAST		CORNER COORDINATES NAD 27, SPCS NM EAST	
A - X: 716794.61' / Y:461763.23'	A - X: 675611.03' / Y:461703.93'	A - X: 675611.03' / Y:461703.93'	A - X: 675611.03' / Y:461703.93'
B - X: 716824.24' / Y:456480.96'	B - X: 675640.50' / Y:456421.80'	B - X: 675640.50' / Y:456421.80'	B - X: 675640.50' / Y:456421.80'
C - X: 716843.83' / Y:451197.02'	C - X: 675659.90' / Y:451137.98'	C - X: 675659.90' / Y:451137.98'	C - X: 675659.90' / Y:451137.98'
D - X: 714202.16' / Y:451180.09'	D - X: 673018.24' / Y:451121.06'	D - X: 673018.24' / Y:451121.06'	D - X: 673018.24' / Y:451121.06'
E - X: 714193.02' / Y:453820.64'	E - X: 673009.20' / Y:453761.54'	E - X: 673009.20' / Y:453761.54'	E - X: 673009.20' / Y:453761.54'
F - X: 714184.36' / Y:456466.14'	F - X: 673000.63' / Y:456406.98'	F - X: 673000.63' / Y:456406.98'	F - X: 673000.63' / Y:456406.98'
G - X: 714154.94' / Y:461748.01'	G - X: 672971.37' / Y:461688.71'	G - X: 672971.37' / Y:461688.71'	G - X: 672971.37' / Y:461688.71'

*FTP TO LTP LINE BEARINGS	
LINE	BEARING
L1	S 00°15'22" E ~ 10367.16'

*FTP TO LTP LEASE DISTANCES	
TRACT	DISTANCE
NMNM 043744	5182.16'
NMNM 055142	5185.00'
TOTAL	10367.16'

○ Drill Line Events ● Section Corners — Drill Line ← Dimension Lines □ Federal Leases □ HSU ○ HSU Corners JOB No. OXY_0033_PT_14723
 All bearings and coordinates refer to New Mexico State Plane Coordinate System, East Zone, U.S. Survey Feet. REV 1 NDS 2/25/2025

Distances/areas relative to NAD 83 grid measurements. Combined Scale Factor: 0.99978064 and a Convergence Angle: 0.30307491°



PECOS DISTRICT DRILLING CONDITIONS OF APPROVAL

OPERATOR'S NAME: OXY USA INC.
WELL NAME & NO.: PLATINUM MDP1 34-3 FEDERAL COM 52H
LOCATION: SEC34 T23S R31E-NMP
COUNTY: <input style="width: 200px;" type="text" value="Eddy County, New Mexico"/>

Create COAs

H₂S	Cave / Karst	Waste Prevention Rule
<input style="width: 100%;" type="text" value="Present"/>	<input style="width: 100%;" type="text" value="Low"/>	<input style="width: 100%;" type="text" value="Waste Minimization Plan"/>
Potash	R-111-Q Design	
<input style="width: 100%;" type="text" value="R-111-Q"/>	<input style="width: 100%;" type="text" value="4-String: Open 1st Int x 2nd Annulus (ICP 2 below Relief Zone)"/>	
Wellhead	Casing	
<input style="width: 100%;" type="text" value="Multibowl"/>	<input style="width: 100%;" type="text" value="4-String Well"/>	
<input checked="" type="checkbox"/> Flex Hose <input checked="" type="checkbox"/> Break Testing	<input type="checkbox"/> Liner <input type="checkbox"/> Fluid Filled <input type="checkbox"/> Casing Clearance	
	Cementing	
	<input type="checkbox"/> DV Tool <input type="checkbox"/> Bradenhead <input type="checkbox"/> Echometer <input checked="" type="checkbox"/> Offline Cement <input checked="" type="checkbox"/> Open Annulus <input type="checkbox"/> Pilot Hole	
Special Requirements		
<input type="checkbox"/> Capitan Reef <input type="checkbox"/> Water Disposal <input checked="" type="checkbox"/> COM <input type="checkbox"/> Unit		

A. HYDROGEN SULFIDE

A Hydrogen Sulfide (H₂S) Drilling Plan shall be activated AT SPUD. As a result, the Hydrogen Sulfide area must meet all requirements from 43 CFR 3176, which includes equipment and personnel/public protection items. If Hydrogen Sulfide is encountered, please provide measured values and formations to the BLM.

APD is within the R-111-Q defined boundary. Operator must follow all procedures and requirements listed within the updated order.

B. CASING

1. The 13-3/8 inch surface casing shall be set at approximately 741 feet (a minimum of 70' into the Rustler Anhydrite, above the salt, and below usable fresh water) and cemented to the surface. **Set depth adjusted per BLM geologist.**

The operator proposes to set surface casing at 613':BLM proposes 741' penetration into

the (adjacent to Lea county) Rustler formation managing BLM identified groundwater zones. If salt is encountered, set casing at least 25 feet above the salt.

- a. If cement does not circulate to the surface, the appropriate BLM office shall be notified and a temperature survey utilizing an electronic-type temperature survey with surface log readout will be used or a cement bond log shall be run to verify the top of the cement. Temperature survey will be run a minimum of six hours after pumping cement and ideally between 8-10 hours after completing the cement job.
 - b. Wait on cement (WOC) time for a primary cement job will be a minimum of **8 hours** or **500 pounds compressive strength**, whichever is greater (including lead cement.)
 - c. Wait on cement (WOC) time for a remedial job will be a minimum of 4 hours after bringing cement to surface or 500 pounds compressive strength, whichever is greater.
 - d. If cement falls back, remedial cementing will be done prior to drilling out that string.
2. The minimum required fill of cement behind the **10-3/4** inch 1st intermediate casing is **cement to surface**. If cement does not circulate, see B.1.a, c-d above.
- **Wait on cement (WOC) time for a primary cement job is to include the lead cement slurry** due to the presence of cave/karst, Capitan Reef, or potash features.
3. The minimum required fill of cement behind the **7-5/8** inch 2nd intermediate casing is **500 feet** into the previous casing but not higher than USGS Marker Bed No. 126 (base of the McNutt Potash ore zone.)
- Operator must verify top of cement per R-111-Q requirements. Submit results to the BLM. If cement does not circulate, contact the appropriate BLM office.
 - **Wait on cement (WOC) time for a primary cement job is to include the lead cement slurry** due to the presence of cave/karst, Capitan Reef, or potash features.
 - **A monitored open annulus will be incorporated during completion by leaving the above annulus un-cemented and monitored.** Operator must follow **all** monitoring requirements listed within R-111-Q. Tieback shall be met within **180 days**.
 - Operator has proposed an open annulus completion in R-111-Q. Operator shall provide a method of verification pre-completion top of cement. **Submit results to the BLM.**
 - Pressure monitoring device and Pressure Safety Valves must be installed at surface on both the intermediate annulus and the production annulus for the life of the well.
 - **In the event of a casing failure during completion,** the operator **must** contact the BLM at engineers (575-706-2779) and inspection staff (575-361-2822 Eddy County).

FOR INTERMEDIATE 2, KEEP CASING FULL DURING RUN FOR COLLAPSE SF. KEEP HOLE FULL FOR TENSILE SF (BOUYANT OK.) REVIEW EXTERNAL PRESSURE FOR PT

4. The minimum required fill of cement behind the 5-1/2 inch production casing is **500 feet** into the previous casing but not higher than USGS Marker Bed No. 126 (base of the McNutt Potash ore zone.)
 - Operator must verify top of cement per R-111-Q requirements. Submit results to the BLM. If cement does not circulate, contact the appropriate BLM office.
 - **Wait on cement (WOC) time for a primary cement job is to include the lead cement slurry** due to the presence of cave/karst, Capitan Reef, or potash features.

C. PRESSURE CONTROL

1. Operator has proposed a multi-bowl wellhead assembly. Minimum working pressure of the blowout preventer (BOP) and related equipment (BOPE) required for drilling below the surface casing shoe shall be **10,000 (10M) psi. Variance is approved to use a 5000 (5M) annular which shall be tested to 3500 (3.5M) psi.**
 - a. Wellhead shall be installed by manufacturer's representatives, submit documentation with subsequent sundry.
 - b. If the welding is performed by a third party, the manufacturer's representative shall monitor the temperature to verify that it does not exceed the maximum temperature of the seal.
 - c. Manufacturer representative shall install the test plug for the initial BOP test.
 - d. If the cement does not circulate and one-inch operations would have been possible with a standard wellhead, the well head shall be cut off, cementing operations performed and another wellhead installed.
 - e. Whenever any seal subject to test pressure is broken, all the tests in 43 CFR 3172 must be followed.
2. Variance approved to use flex line from BOP to choke manifold. Manufacturer's specification to be readily available. No external damage to flex line. Flex line to be installed as straight as possible (no hard bends).
3. Break testing has been approved for this well ONLY on those intervals utilizing a 5M BOPE or less. **(Annular preventer must be tested to a minimum of 70% of BOPE working pressure and shall be higher than the MASP.)** If in the event break testing is not utilized, then a full BOPE test would be conducted.
 - BOPE Break Testing is ONLY permitted for hole sections with 5M MASP or less.
 - The break test should involve a shell test that includes testing the upper pipe rams as proposed.
 - Variance only pertains to the hole-sections in and shallower than the Wolfcamp formation. Break testing is NOT allowed when planning to penetrate the Penn group.

- While in transfer between wells, the BOPE shall be secured by the hydraulic carrier or cradle in accordance with API STD 53.
- Any well control event while drilling require notification to the BLM Petroleum Engineer.
- A full BOPE test is required prior to drilling the first intermediate section.
- If a hole section tends to show more background gas than normal, please notify BLM Engineer prior to proceeding with break testing on the next well.
- The BLM PET is to be contacted 4 hours prior to BOPE tests.
 - Eddy County Petroleum Engineering Inspection Staff: (575) 361-2822
 - Lea County Petroleum Engineering Inspection Staff: (575) 689-5981
- As a minimum, a full BOPE test shall be performed at 21-day intervals.
- In the event any repairs or replacement of the BOPE is required, the BOPE shall test as per 43 CFR 3172.

D. SPECIAL REQUIREMENT(S)

Communitization Agreement:

- The operator will submit a Communitization Agreement to the Santa Fe Office, 301 Dinosaur Trail Santa Fe, New Mexico 87508, at least 90 days before the anticipated date of first production from a well subject to a spacing order issued by the New Mexico Oil Conservation Division. The Communitization Agreement will include the signatures of all working interest owners in all Federal and Indian leases subject to the Communitization Agreement (i.e., operating rights owners and lessees of record), or certification that the operator has obtained the written signatures of all such owners and will make those signatures available to the BLM immediately upon request.
- The operator will submit an as-drilled survey well plat of the well completion, but are not limited to, those specified in 43 CFR 3171 and 3172.
- If the operator does not comply with this condition of approval, the BLM may take enforcement actions that include, but are not limited to, those specified in 43 CFR 3163.1.
- In addition, the well sign shall include the surface and bottom hole lease numbers. When the Communitization Agreement number is known, it shall also be on the sign.

Offline Cementing

Offline cementing has been approved for **all hole sections, excluding production**. Contact the BLM prior to the commencement of any offline cementing procedure.

GENERAL REQUIREMENTS

The BLM is to be notified in advance for a representative to witness:

- a. Spudding well (minimum of 24 hours)
- b. Setting and/or Cementing of all casing strings (minimum of 4 hours)
- c. BOPE tests (minimum of 4 hours)

Contact Lea County Petroleum Engineering Inspection Staff:

Call the Hobbs Field Station, 414 West Taylor, Hobbs NM 88240, (575) 689-5981

Contact Eddy County Petroleum Engineering Inspection Staff:

Email or call the Carlsbad Field Office, 620 East Greene St., Carlsbad, NM 88220;
[BLM NM CFO DrillingNotifications@BLM.GOV](mailto:BLM_NM_CFO_DrillingNotifications@BLM.GOV); (575) 361-2822

1. Unless the production casing has been run and cemented or the well has been properly plugged, the drilling rig shall not be removed from over the hole without prior approval.
 - a. In the event the operator has proposed to drill multiple wells utilizing a skid/walking rig. Operator shall secure the wellbore on the current well, after installing and testing the wellhead, by installing a blind flange of like pressure rating to the wellhead and a pressure gauge that can be monitored while drilling is performed on the other well(s).
 - b. When the operator proposes to set surface casing with Spudder Rig
 - i. Notify the BLM when moving in and removing the Spudder Rig.
 - ii. Notify the BLM when moving in the 2nd Rig. Rig to be moved in within 90 days of notification that Spudder Rig has left the location.
 - iii. BOP/BOPE test to be conducted per **43 CFR 3172** as soon as 2nd Rig is rigged up on well.
2. Floor controls are required for 3M or Greater systems. These controls will be on the rig floor, unobstructed, readily accessible to the driller and will be operational at all times during drilling and/or completion activities. Rig floor is defined as the area immediately around the rotary table; the area immediately above the substructure on which the draw works are located, this does not include the dog house or stairway area.
3. For intervals in which cement to surface is required, cement to surface should be verified with a visual check and density or pH check to differentiate cement from spacer and drilling mud. The results should be documented in the driller's log and daily reports.

A. CASING

1. Changes to the approved APD casing program need prior approval if the items substituted are of lesser grade or different casing size or are Non-API. The Operator can exchange the components of the proposal with that of superior strength (i.e.

- changing from J-55 to N-80, or from 36# to 40#). Changes to the approved cement program need prior approval if the altered cement plan has less volume or strength or if the changes are substantial (i.e. Multistage tool, ECP, etc.). The initial wellhead installed on the well will remain on the well with spools used as needed.
2. Wait on cement (WOC) for Potash Areas: After cementing but before commencing any tests, the casing string shall stand cemented under pressure until both of the following conditions have been met: 1) cement reaches a minimum compressive strength of 500 psi for all cement blends of both lead and tail cement, 2) until cement has been in place at least 8 hours. WOC time will be recorded in the driller's log. The casing integrity test can be done (prior to the cement setting up) immediately after bumping the plug.
 3. Wait on cement (WOC) for Water Basin: After cementing but before commencing any tests, the casing string shall stand cemented under pressure until both of the following conditions have been met: 1) cement reaches a minimum compressive strength of 500 psi at the shoe, 2) until cement has been in place at least 8 hours. WOC time will be recorded in the driller's log. See individual casing strings for details regarding lead cement slurry requirements. The casing integrity test can be done (prior to the cement setting up) immediately after bumping the plug.
 4. Provide compressive strengths including hours to reach required 500 pounds compressive strength prior to cementing each casing string. Have well specific cement details onsite prior to pumping the cement for each casing string.
 5. No pea gravel permitted for remedial or fall back remedial without prior authorization from the BLM engineer.
 6. On that portion of any well approved for a 5M BOPE system or greater, a pressure integrity test of each casing shoe shall be performed. Formation at the shoe shall be tested to a minimum of the mud weight equivalent anticipated to control the formation pressure to the next casing depth or at total depth of the well. This test shall be performed before drilling more than 20 feet of new hole.
 7. If hardband drill pipe is rotated inside casing, returns will be monitored for metal. If metal is found in samples, drill pipe will be pulled and rubber protectors which have a larger diameter than the tool joints of the drill pipe will be installed prior to continuing drilling operations.
 8. Whenever a casing string is cemented in the R-111-Q potash area, the NMOCD requirements shall be followed.

B. PRESSURE CONTROL

1. All blowout preventer (BOP) and related equipment (BOPE) shall comply with well control requirements as described in **43 CFR 3172**.
2. If a variance is approved for a flexible hose to be installed from the BOP to the choke manifold, the following requirements apply: The flex line must meet the requirements of API 16C. Check condition of flexible line from BOP to choke manifold, replace if

- exterior is damaged or if line fails test. Line to be as straight as possible with no hard bends and is to be anchored according to Manufacturer's requirements. The flexible hose can be exchanged with a hose of equal size and equal or greater pressure rating. Anchor requirements, specification sheet and hydrostatic pressure test certification matching the hose in service, to be onsite for review. These documents shall be posted in the company man's trailer and on the rig floor.
3. 5M or higher system requires an HCR valve, remote kill line and annular to match. The remote kill line is to be installed prior to testing the system and tested to stack pressure.
 4. If the operator has proposed a multi-bowl wellhead assembly in the APD. The following requirements must be met:
 - i. Wellhead shall be installed by manufacturer's representatives, submit documentation with subsequent sundry.
 - ii. If the welding is performed by a third party, the manufacturer's representative shall monitor the temperature to verify that it does not exceed the maximum temperature of the seal.
 - iii. Manufacturer representative shall install the test plug for the initial BOP test.
 - iv. Whenever any seal subject to test pressure is broken, all the tests in 43 CFR 3172.6(b)(9) must be followed.
 - v. If the cement does not circulate and one inch operations would have been possible with a standard wellhead, the well head shall be cut off, cementing operations performed and another wellhead installed.
 5. The appropriate BLM office shall be notified a minimum of 4 hours in advance for a representative to witness the tests.
 - i. In a water basin, for all casing strings utilizing slips, these are to be set as soon as the crew and rig are ready and any fallback cement remediation has been done. The casing cut-off and BOP installation can be initiated four hours after installing the slips, which will be approximately six hours after bumping the plug. For those casing strings not using slips, the minimum wait time before cut-off is eight hours after bumping the plug. BOP/BOPE testing can begin after cut-off or once cement reaches 500 psi compressive strength (including lead cement), whichever is greater. However, if the float does not hold, cut-off cannot be initiated until cement reaches 500 psi compressive strength (including lead when specified).
 - ii. In potash areas, for all casing strings utilizing slips, these are to be set as soon as the crew and rig are ready and any fallback cement remediation has been done. For all casing strings, casing cut-off and BOP installation can be initiated at twelve hours after bumping the cement plug. The BOPE test can be initiated after bumping the cement plug with the casing valve open. (only applies to single stage cement jobs, prior to the cement setting up.)

- iii. The tests shall be done by an independent service company utilizing a test plug not a cup or J-packer and can be initiated immediately with the casing valve open. The operator also has the option of utilizing an independent tester to test without a plug (i.e. against the casing) pursuant to **43 CFR 3172** with the pressure not to exceed 70% of the burst rating for the casing. Any test against the casing must meet the WOC time for 8 hours or 500 pounds compressive strength, whichever is greater, prior to initiating the test (see casing segment as lead cement may be critical item).
- iv. The test shall be run on a 5000 psi chart for a 2-3M BOP/BOP, on a 10000 psi chart for a 5M BOP/BOPE and on a 15000 psi chart for a 10M BOP/BOPE. If a linear chart is used, it shall be a one hour chart. A circular chart shall have a maximum 2 hour clock. If a twelve hour or twenty-four hour chart is used, tester shall make a notation that it is run with a two hour clock.
- v. The results of the test shall be reported to the appropriate BLM office.
- vi. All tests are required to be recorded on a calibrated test chart. A copy of the BOP/BOPE test chart and a copy of independent service company test will be submitted to the appropriate BLM office.
- vii. The BOP/BOPE test shall include a low pressure test from 250 to 300 psi. The test will be held for a minimum of 10 minutes if test is done with a test plug and 30 minutes without a test plug. This test shall be performed prior to the test at full stack pressure.
- viii. BOP/BOPE must be tested by an independent service company within 500 feet of the top of the Wolfcamp formation if the time between the setting of the intermediate casing and reaching this depth exceeds 20 days. This test does not exclude the test prior to drilling out the casing shoe as per **43 CFR 3172**.

C. DRILLING MUD

Mud system monitoring equipment, with derrick floor indicators and visual and audio alarms, shall be operating before drilling into the Wolfcamp formation, and shall be used until production casing is run and cemented.

D. WASTE MATERIAL AND FLUIDS

All waste (i.e. drilling fluids, trash, salts, chemicals, sewage, gray water, etc.) created as a result of drilling operations and completion operations shall be safely contained and disposed of properly at a waste disposal facility. No waste material or fluid shall be disposed of on the well location or surrounding area. Porto-johns and trash containers will be on-location during fracturing operations or any other crew-intensive operations.

KPI 1/13/2026



Permian Drilling Hydrogen Sulfide Drilling Operations Plan New Mexico

Scope

This contingency plan establishes guidelines for the public, all company employees, and contract employees who's work activities may involve exposure to hydrogen sulfide (H₂S) gas.

While drilling this well, it is possible to encounter H₂S bearing formations. At all times, the first barrier to control H₂S emissions will be the drilling fluid, which will have a density high enough to control influx.

Objective

1. Provide an immediate and predetermined response plan to any condition when H₂S is detected. All H₂S detections in excess of 10 parts per million (ppm) concentration are considered an Emergency.
2. Prevent any and all accidents, and prevent the uncontrolled release of hydrogen sulfide into the atmosphere.
3. Provide proper evacuation procedures to cope with emergencies.
4. Provide immediate and adequate medical attention should an injury occur.

Discussion

Implementation:	This plan with all details is to be fully implemented before drilling to <u>commence</u> .
Emergency response Procedure:	This section outlines the conditions and denotes steps to be taken in the event of an emergency.
Emergency equipment Procedure:	This section outlines the safety and emergency equipment that will be required for the drilling of this well.
Training provisions:	This section outlines the training provisions that must be adhered to prior to drilling.
Drilling emergency call lists:	Included are the telephone numbers of all persons to be contacted should an emergency exist.
Briefing:	This section deals with the briefing of all people involved in the drilling operation.
Public safety:	Public safety personnel will be made aware of any potential evacuation and any additional support needed.
Check lists:	Status check lists and procedural check lists have been included to insure adherence to the plan.
General information:	A general information section has been included to supply support information.

Hydrogen Sulfide Training

All personnel, whether regularly assigned, contracted, or employed on an unscheduled basis, will receive training from a qualified instructor in the following areas prior to commencing drilling operations on the well:

1. The hazards and characteristics of H2S.
2. Proper use and maintenance of personal protective equipment and life support systems.
3. H2S detection.
4. Proper use of H2S detectors, alarms, warning systems, briefing areas, evacuation procedures and prevailing winds.
5. Proper techniques for first aid and rescue procedures.
6. Physical effects of hydrogen sulfide on the human body.
7. Toxicity of hydrogen sulfide and sulfur dioxide.
8. Use of SCBA and supplied air equipment.
9. First aid and artificial respiration.
10. Emergency rescue.

In addition, supervisory personnel will be trained in the following areas:

1. The effects of H2S on metal components. If high tensile strength tubular is to be used, personnel will be trained in their special maintenance requirements.
2. Corrective action and shut-in procedures when drilling a well, blowout prevention and well control procedures.
3. The contents and requirements of the H2S Drilling Operations Plan.

H2S training refresher must have been taken within one year prior to drilling the well. Specifics on the well to be drilled will be discussed during the pre-spud meeting. H2S and well control (choke) drills will be performed while drilling the well, at least on a weekly basis. This plan shall be available in the well site. All personnel will be required to carry the documentation proving that the H2S training has been taken.

Service company and visiting personnel

- A. Each service company that will be on this well will be notified if the zone contains H2S.
- B. Each service company must provide for the training and equipment of their employees before they arrive at the well site.
- C. Each service company will be expected to attend a well site

Emergency Equipment Requirements

1. Well control equipment

The well shall have hydraulic BOP equipment for the anticipated pressures. Equipment is to be tested on installation and follow Oxy Well Control standard, as well as 43 CFR part 3170 Subpart 3172.

Special control equipment:

- A. Hydraulic BOP equipment with remote control on ground.
Remotely operated choke.
- B. Rotating head
- C. Gas buster equipment shall be installed before drilling out of surface pipe.

2. Protective equipment for personnel

- A. Four (4) 30-minute positive pressure air packs (2 at each briefing area) on location.
- B. Adequate fire extinguishers shall be located at strategic locations.
- C. Radio / cell telephone communication will be available at the rig.
 - Rig floor and trailers.
 - Vehicle.

3. Hydrogen sulfide sensors and alarms

- A. H₂S sensor with alarms will be located on the rig floor, at the bell nipple, and at the flow line. These monitors will be set to alarm at 10 ppm with strobe light, and audible alarm.
- B. Hand operated detectors with tubes.
- C. H₂S monitor tester (to be provided by contract Safety Company.)
- D. There shall be one combustible gas detector on location at all times.

4. Visual Warning Systems

- A. One sign located at each location entrance with the following language:

**Caution – potential poison gas
Hydrogen sulfide
No admittance without authorization**

Wind sock – wind streamers:

- A. One 36” (in length) wind sock located at protection center, at height visible from rig floor.
- B. One 36” (in length) wind sock located at height visible from pit areas.

Condition flags

- A. One each condition flag to be displayed to denote conditions.

green – normal conditions
yellow – potential danger
red – danger, H2S present

- B. Condition flag shall be posted at each location sign entrance.

5. Mud Program

The mud program is designed to minimize the risk of having H2S and other formation fluids at surface. Proper mud weight and safe drilling practices will be applied. H2S scavengers will be used to minimize the hazards while drilling. Below is a summary of the drilling program.

Mud inspection devices:

Garrett gas train or hatch tester for inspection of sulfide concentration in mud system.

6. Metallurgy

- A. Drill string, casing, tubing, wellhead, blowout preventers, drilling spools or adapters, kill lines, choke manifold, lines and valves shall be suitable for the H2S service.
- B. All the elastomers, packing, seals and ring gaskets shall be suitable for H2S service.

7. Well Testing

No drill stem test will be performed on this well.

8. Evacuation plan

Evacuation routes should be established prior to well spud for each well and discussed with all rig personnel.

9. Designated area

- A. Parking and visitor area: all vehicles are to be parked at a predetermined safe distance from the wellhead.
- B. There will be a designated smoking area.
- C. Two briefing areas on either side of the location at the maximum allowable distance from the well bore so they offset prevailing winds perpendicularly, or at a 45-degree angle if wind direction tends to shift in the area.

Emergency procedures

- A. In the event of any evidence of H₂S level above 10 ppm, take the following steps:
 - 1. The Driller will pick up off bottom, shut down the pumps, slow down the pipe rotation.
 - 2. Secure and don escape breathing equipment, report to the upwind designated safe briefing / muster area.
 - 3. All personnel on location will be accounted for and emergency search should begin for any missing, the Buddy System will be implemented.
 - 4. Order non-essential personnel to leave the well site, order all essential personnel out of the danger zone and upwind to the nearest designated safe briefing / muster area.
 - 5. Entrance to the location will be secured to a higher level than our usual "Meet and Greet" requirement, and the proper condition flag will be displayed at the entrance to the location.
 - 6. Take steps to determine if the H₂S level can be corrected or suppressed and, if so, proceed as required.
- B. If uncontrollable conditions occur:
 - 1. Take steps to protect and/or remove any public in the down-wind area from the rig – partial evacuation and isolation. Notify necessary public safety personnel and appropriate regulatory entities (i.e. BLM) of the situation.

2. Remove all personnel to the nearest upwind designated safe briefing / muster area or off location.
3. Notify public safety personnel of safe briefing / muster area.
4. An assigned crew member will blockade the entrance to the location. No unauthorized personnel will be allowed entry to the location.
5. Proceed with best plan (at the time) to regain control of the well. Maintain tight security and safety procedures.

C. Responsibility:

1. Designated personnel.
 - a. Shall be responsible for the total implementation of this plan.
 - b. Shall be in complete command during any emergency.
 - c. Shall designate a back-up.

- All personnel:
1. On alarm, don escape unit and report to the nearest upwind designated safe briefing / muster area upw
 2. Check status of personnel (buddy system).
 3. Secure breathing equipment.
 4. Await orders from supervisor.

- Drill site manager:
1. Don escape unit if necessary and report to nearest upwind designated safe briefing / muster area.
 2. Coordinate preparations of individuals to return to point of release with tool pusher and driller (using the buddy system).
 3. Determine H2S concentrations.
 4. Assess situation and take control measures.

- Tool pusher:
1. Don escape unit Report to up nearest upwind designated safe briefing / muster area.
 2. Coordinate preparation of individuals to return to point of release with tool pusher drill site manager (using the buddy system).
 3. Determine H2S concentration.
 4. Assess situation and take control measures.

- Driller:
1. Don escape unit, shut down pumps, continue

- rotating DP.
- 2. Check monitor for point of release.
- 3. Report to nearest upwind designated safe briefing / muster area.
- 4. Check status of personnel (in an attempt to rescue, use the buddy system).
- 5. Assigns least essential person to notify Drill Site Manager and tool pusher by quickest means in case of their absence.
- 6. Assumes the responsibilities of the Drill Site Manager and tool pusher until they arrive should they be absent.

Derrick man
 Floor man #1
 Floor man #2

- 1. Will remain in briefing / muster area until instructed by supervisor.

Mud engineer:

- 1. Report to nearest upwind designated safe briefing / muster area.
- 2. When instructed, begin check of mud for ph and H2S level. (Garett gas train.)

Safety personnel:

- 1. Mask up and check status of all personnel and secure operations as instructed by drill site manager.

Taking a kick

When taking a kick during an H2S emergency, all personnel will follow standard Well control procedures after reporting to briefing area and masking up.

Open-hole logging

All unnecessary personnel off floor. Drill Site Manager and safety personnel should monitor condition, advise status and determine need for use of air equipment.

Running casing or plugging

Following the same “tripping” procedure as above. Drill Site Manager and safety personnel should determine if all personnel have access to protective equipment.

Ignition procedures

The decision to ignite the well is the responsibility of the operator (Oxy Drilling Management). The decision should be made only as a last resort and in a situation where it is clear that:

1. Human life and property are endangered.
2. There is no hope controlling the blowout under the prevailing conditions at the well.

Instructions for igniting the well

1. Two people are required for the actual igniting operation. They must wear self-contained breathing units and have a safety rope attached. One man (tool pusher or safety engineer) will check the atmosphere for explosive gases with the gas monitor. The other man is responsible for igniting the well.
2. Primary method to ignite: 25 mm flare gun with range of approximately 500 feet.
3. Ignite upwind and do not approach any closer than is warranted.
4. Select the ignition site best for protection, and which offers an easy escape route.
5. Before firing, check for presence of combustible gas.
6. After lighting, continue emergency action and procedure as before.
7. All unassigned personnel will remain in briefing area until instructed by supervisor or directed by the Drill Site Manager.

Remember: After well is ignited, burning hydrogen sulfide will convert to sulfur dioxide, which is also highly toxic. **Do not assume the area is safe after the well is ignited.**

Status check list

Note: All items on this list must be completed before drilling to production casing point.

1. H2S sign at location entrance.
2. Two (2) wind socks located as required.
3. Four (4) 30-minute positive pressure air packs (2 at each Briefing area) on location for all rig personnel and mud loggers.
4. Air packs inspected and ready for use.
5. Cascade system and hose line hook-up as needed.
6. Cascade system for refilling air bottles as needed.
7. Condition flag on location and ready for use.
8. H2S detection system hooked up and tested.
9. H2S alarm system hooked up and tested.
10. Hand operated H2S detector with tubes on location.
11. 1 – 100' length of nylon rope on location.
12. All rig crew and supervisors trained as required.
13. All outside service contractors advised of potential H2S hazard on well.
14. No smoking sign posted and a designated smoking area identified.
15. Calibration of all H2S equipment shall be noted on the IADC report.

Checked by: _____ Date:

Procedural check list during H2S events

Perform each tour:

1. Check fire extinguishers to see that they have the proper charge.
2. Check breathing equipment to ensure that it in proper working order.
3. Make sure all the H2S detection system is operative.

Perform each week:

1. Check each piece of breathing equipment to make sure that demand or forced air regulator is working. This requires that the bottle be opened and the mask assembly be put on tight enough so that when you inhale, you receive air or feel air flow.
2. BOP skills (well control drills).
3. Check supply pressure on BOP accumulator stand by source.
4. Check breathing equipment mask assembly to see that straps are loosened and turned back, ready to put on.
5. Check pressure on breathing equipment air bottles to make sure they are charged to full volume. (Air quality checked for proper air grade “D” before bringing to location)
6. Confirm pressure on all supply air bottles.
7. Perform breathing equipment drills with on-site personnel.
8. Check the following supplies for availability.
 - A. Emergency telephone list.
 - B. Hand operated H2S detectors and tubes.

General evacuation plan

1. When the company approved supervisor (Drill Site Manager, consultant, rig pusher, or driller) determines the H2S gas cannot be limited to the well location and the public will be involved, he will activate the evacuation plan.
2. Drill Site Manager or designee will notify local government agency that a hazardous condition exists and evacuation needs to be implemented.
3. Company or contractor safety personnel that have been trained in the use of H2S detection equipment and self-contained breathing equipment will monitor H2S concentrations, wind directions, and area of exposure. They will delineate the outer perimeter of the hazardous gas area. Extension to the evacuation area will be determined from information gathered.
4. Law enforcement personnel (state police, police dept., fire dept., and sheriff's dept.) Will be called to aid in setting up and maintaining road blocks. Also, they will aid in evacuation of the public if necessary.
5. After the discharge of gas has been controlled, company safety personnel will determine when the area is safe for re-entry.

Important: Law enforcement personnel will not be asked to come into a contaminated area. Their assistance will be limited to uncontaminated areas. Constant radio contact will be maintained with them.

Emergency actions

Well blowout – if emergency

1. Evacuate all personnel to “Safe Briefing / Muster Areas” or off location if needed.
2. If sour gas – evacuate rig personnel.
3. If sour gas – evacuate public within 3000 ft radius of exposure.
4. Don SCBA and shut well in if possible using the buddy system.
5. Notify Drilling Superintendent and call 911 for emergency help (fire dept and ambulance) if needed.
6. Implement the Blowout Contingency Plan, and Drilling Emergency Action Plan.
6. Give first aid as needed.

Person down location/facility

1. If immediately possible, contact 911. Give location and wait for confirmation.
2. Don SCBA and perform rescue operation using buddy system.

Toxic effects of hydrogen sulfide

Hydrogen sulfide is extremely toxic. The acceptable ceiling concentration for eight-hour exposure is 10 ppm, which is .001% by volume. Hydrogen sulfide is heavier than air (specific gravity – 1.192) and colorless. It forms an explosive mixture with air between 4.3 and 46.0 percent by volume. Hydrogen sulfide is almost as toxic as hydrogen cyanide and is between five and six times more toxic than carbon monoxide. Toxicity data for hydrogen sulfide and various other gases are compared in table i. Physical effects at various hydrogen sulfide exposure levels are shown in table ii.

Table i
Toxicity of various gases

Common name	Chemical formula	Specific gravity (sc=1)	Threshold limit (1)	Hazardous limit (2)	Lethal concentration (3)
Hydrogen Cyanide	Hcn	0.94	10 ppm	150 ppm/hr	300 ppm
Hydrogen Sulfide	H2S	1.18	10 ppm	250 ppm/hr	600 ppm
Sulfur Dioxide	So2	2.21	5 ppm	-	1000 ppm
Chlorine	Cl2	2.45	1 ppm	4 ppm/hr	1000 ppm
Carbon Monoxide	Co	0.97	50 ppm	400 ppm/hr	1000 ppm
Carbon Dioxide	Co2	1.52	5000 ppm	5%	10%
Methane	Ch4	0.55	90,000 ppm	Combustible above 5% in air	

- 1) threshold limit – concentration at which it is believed that all workers may be repeatedly exposed day after day without adverse effects.
- 2) hazardous limit – concentration that will cause death with short-term exposure.
- 3) lethal concentration – concentration that will cause death with short-term exposure.

Toxic effects of hydrogen sulfide

Table ii
Physical effects of hydrogen sulfide

Percent (%)	Ppm	Concentration	Physical effects
		Grains 100 std. Ft3*	
0.001	<10	00.65	Obvious and unpleasant odor.

0.002	10	01.30	Safe for 8 hours of exposure.
0.010	100	06.48	Kill smell in 3 – 15 minutes. May sting eyes and throat.
0.020	200	12.96	Kills smell shortly; stings eyes and throat.
0.050	500	32.96	Dizziness; breathing ceases in a few minutes; needs prompt artificial respiration.
0.070	700	45.36	Unconscious quickly; death will result if not rescued promptly.
0.100	1000	64.30	Unconscious at once; followed by death within minutes.

*at 15.00 psia and 60’f.

Use of self-contained breathing equipment (SCBA)

1. Written procedures shall be prepared covering safe use of SCBA's in dangerous atmosphere, which might be encountered in normal operations or in emergencies. Personnel shall be familiar with these procedures and the available SCBA.
2. SCBA's shall be inspected frequently at random to insure that they are properly used, cleaned, and maintained.
3. Anyone who may use the SCBA's shall be trained in how to insure proper face-piece to face seal. They shall wear SCBA's in normal air and then wear them in a test atmosphere. (note: such items as facial hair {beard or sideburns} and eyeglasses will not allow proper seal.) Anyone that may be reasonably expected to wear SCBA's should have these items removed before entering a toxic atmosphere. A special mask must be obtained for anyone who must wear eyeglasses or contact lenses.
4. Maintenance and care of SCBA's:
 - a. A program for maintenance and care of SCBA's shall include the following:
 1. Inspection for defects, including leak checks.
 2. Cleaning and disinfecting.
 3. Repair.
 4. Storage.
 - b. Inspection, self-contained breathing apparatus for emergency use shall be inspected monthly.
 1. Fully charged cylinders.
 2. Regulator and warning device operation.
 3. Condition of face piece and connections.
 4. Rubber parts shall be maintained to keep them pliable and prevent deterioration.
 - c. Routinely used SCBA's shall be collected, cleaned and disinfected as frequently as necessary to insure proper protection is provided.
5. Persons assigned tasks that requires use of self-contained breathing equipment shall be certified physically fit (medically cleared) for breathing equipment usage at least annually.
6. SCBA's should be worn when:
 - A. Any employee works near the top or on top of any tank unless test reveals less than 10 ppm of H₂S.

- B. When breaking out any line where H2S can reasonably be expected.
- C. When sampling air in areas to determine if toxic concentrations of H2S exists.
- D. When working in areas where over 10 ppm H2S has been detected.
- E. At any time there is a doubt as to the H2S level in the area to be entered.

Rescue
First aid for H2S poisoning

Do not panic!

Remain calm – think!

1. Don SCBA breathing equipment.
2. Remove victim(s) utilizing buddy system to fresh air as quickly as possible. (go up-wind from source or at right angle to the wind. Not down wind.)
3. Briefly apply chest pressure – arm lift method of artificial respiration to clean the victim’s lungs and to avoid inhaling any toxic gas directly from the victim’s lungs.
4. Provide for prompt transportation to the hospital, and continue giving artificial respiration if needed.
5. Hospital(s) or medical facilities need to be informed, before-hand, of the possibility of H2S gas poisoning – no matter how remote the possibility is.
6. Notify emergency room personnel that the victim(s) has been exposed to H2S gas.

Besides basic first aid, everyone on location should have a good working knowledge of artificial respiration.

Revised CM 6/27/2012



Permian Drilling Hydrogen Sulfide Drilling Operations Plan

Open drill site. No homes or buildings are near the proposed location.

1. Escape

Personnel shall escape upwind of wellbore in the event of an emergency gas release. Escape can take place through the lease road on the Southeast side of the location. Personnel need to move to a safe distance and block the entrance to location. If the primary route is not an option due to the wind direction, then a secondary egress route should be taken.

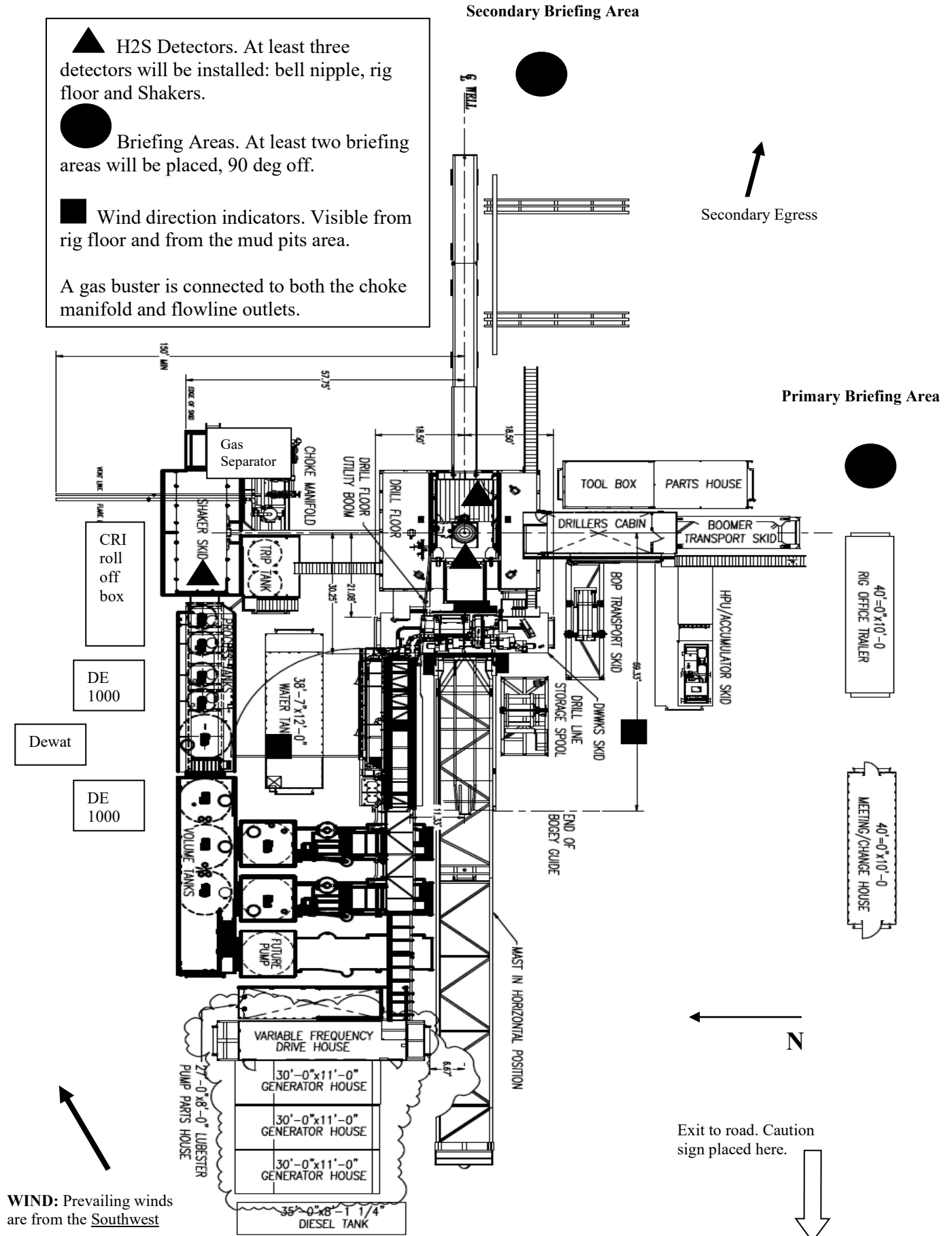

OXY

PRD NM DIRECTIONAL PLANS (NAD 1983)

PLATINUM MDP1 34-3 FED COM

Platinum MDP1 34_3 Fed Com 52H

Wellbore #1

Plan: Permitting Plan

Standard Planning Report

21 June, 2024

OXY Planning Report

Database:	HOPSPP	Local Co-ordinate Reference:	Well Platinum MDP1 34_3 Fed Com 52H
Company:	ENGINEERING DESIGNS	TVD Reference:	RKB=25' @ 3445.00ft
Project:	PRD NM DIRECTIONAL PLANS (NAD 1983)	MD Reference:	RKB=25' @ 3445.00ft
Site:	PLATINUM MDP1 34-3 FED COM	North Reference:	Grid
Well:	Platinum MDP1 34_3 Fed Com 52H	Survey Calculation Method:	Minimum Curvature
Wellbore:	Wellbore #1		
Design:	Permitting Plan		

Project	PRD NM DIRECTIONAL PLANS (NAD 1983)		
Map System:	US State Plane 1983	System Datum:	Mean Sea Level
Geo Datum:	North American Datum 1983		
Map Zone:	New Mexico Eastern Zone		Using geodetic scale factor

Site	PLATINUM MDP1 34-3 FED COM		
Site Position:		Northing:	461,352.44 usft
From:	Map	Easting:	714,923.95 usft
Position Uncertainty:	44.72 ft	Slot Radius:	13.200 in
		Latitude:	32.267084
		Longitude:	-103.771726

Well	Platinum MDP1 34_3 Fed Com 52H		
Well Position	+N/-S	0.00 ft	Northing: 461,633.61 usf
	+E/-W	0.00 ft	Easting: 716,017.25 usf
Position Uncertainty		2.00 ft	Wellhead Elevation: ft
Grid Convergence:		0.30 °	Ground Level: 3,420.00 ft
			Latitude: 32.267841
			Longitude: -103.768184

Wellbore	Wellbore #1				
Magnetics	Model Name	Sample Date	Declination (°)	Dip Angle (°)	Field Strength (nT)
	HDGM_FILE	6/21/2024	6.30	59.80	47,402.90000000

Design	Permitting Plan			
Audit Notes:				
Version:	Phase:	PROTOTYPE	Tie On Depth:	0.00
Vertical Section:	Depth From (TVD) (ft)	+N/-S (ft)	+E/-W (ft)	Direction (°)
	0.00	0.00	0.00	182.60

Plan Survey Tool Program	Date	6/21/2024		
Depth From (ft)	Depth To (ft)	Survey (Wellbore)	Tool Name	Remarks
1	0.00	22,894.47	Permitting Plan (Wellbore #1)	B005Mc_MWD+HRGM+SA MWD+HRGM+Sag+MSA

Plan Sections										
Measured Depth (ft)	Inclination (°)	Azimuth (°)	Vertical Depth (ft)	+N/-S (ft)	+E/-W (ft)	Dogleg Rate (°/100ft)	Build Rate (°/100ft)	Turn Rate (°/100ft)	TFO (°)	Target
0.00	0.00	0.00	0.00	0.00	0.00	0.00	0.00	0.00	0.00	
9,100.00	0.00	0.00	9,100.00	0.00	0.00	0.00	0.00	0.00	0.00	
10,099.66	10.00	279.66	10,094.60	14.60	-85.75	1.00	1.00	0.00	279.66	
12,053.34	10.00	279.66	12,018.61	71.51	-420.08	0.00	0.00	0.00	0.00	
12,970.47	90.00	179.74	12,600.00	-501.63	-518.47	10.00	8.72	-10.89	-99.77	
22,894.47	90.00	179.74	12,600.00	-10,425.53	-474.21	0.00	0.00	0.00	0.00	PBHL (Platinum)

OXY Planning Report

Database:	HOPSPP	Local Co-ordinate Reference:	Well Platinum MDP1 34_3 Fed Com 52H
Company:	ENGINEERING DESIGNS	TVD Reference:	RKB=25' @ 3445.00ft
Project:	PRD NM DIRECTIONAL PLANS (NAD 1983)	MD Reference:	RKB=25' @ 3445.00ft
Site:	PLATINUM MDP1 34-3 FED COM	North Reference:	Grid
Well:	Platinum MDP1 34_3 Fed Com 52H	Survey Calculation Method:	Minimum Curvature
Wellbore:	Wellbore #1		
Design:	Permitting Plan		

Planned Survey									
Measured Depth (ft)	Inclination (°)	Azimuth (°)	Vertical Depth (ft)	+N/-S (ft)	+E/-W (ft)	Vertical Section (ft)	Dogleg Rate (°/100ft)	Build Rate (°/100ft)	Turn Rate (°/100ft)
0.00	0.00	0.00	0.00	0.00	0.00	0.00	0.00	0.00	0.00
100.00	0.00	0.00	100.00	0.00	0.00	0.00	0.00	0.00	0.00
200.00	0.00	0.00	200.00	0.00	0.00	0.00	0.00	0.00	0.00
300.00	0.00	0.00	300.00	0.00	0.00	0.00	0.00	0.00	0.00
400.00	0.00	0.00	400.00	0.00	0.00	0.00	0.00	0.00	0.00
500.00	0.00	0.00	500.00	0.00	0.00	0.00	0.00	0.00	0.00
600.00	0.00	0.00	600.00	0.00	0.00	0.00	0.00	0.00	0.00
700.00	0.00	0.00	700.00	0.00	0.00	0.00	0.00	0.00	0.00
800.00	0.00	0.00	800.00	0.00	0.00	0.00	0.00	0.00	0.00
900.00	0.00	0.00	900.00	0.00	0.00	0.00	0.00	0.00	0.00
1,000.00	0.00	0.00	1,000.00	0.00	0.00	0.00	0.00	0.00	0.00
1,100.00	0.00	0.00	1,100.00	0.00	0.00	0.00	0.00	0.00	0.00
1,200.00	0.00	0.00	1,200.00	0.00	0.00	0.00	0.00	0.00	0.00
1,300.00	0.00	0.00	1,300.00	0.00	0.00	0.00	0.00	0.00	0.00
1,400.00	0.00	0.00	1,400.00	0.00	0.00	0.00	0.00	0.00	0.00
1,500.00	0.00	0.00	1,500.00	0.00	0.00	0.00	0.00	0.00	0.00
1,600.00	0.00	0.00	1,600.00	0.00	0.00	0.00	0.00	0.00	0.00
1,700.00	0.00	0.00	1,700.00	0.00	0.00	0.00	0.00	0.00	0.00
1,800.00	0.00	0.00	1,800.00	0.00	0.00	0.00	0.00	0.00	0.00
1,900.00	0.00	0.00	1,900.00	0.00	0.00	0.00	0.00	0.00	0.00
2,000.00	0.00	0.00	2,000.00	0.00	0.00	0.00	0.00	0.00	0.00
2,100.00	0.00	0.00	2,100.00	0.00	0.00	0.00	0.00	0.00	0.00
2,200.00	0.00	0.00	2,200.00	0.00	0.00	0.00	0.00	0.00	0.00
2,300.00	0.00	0.00	2,300.00	0.00	0.00	0.00	0.00	0.00	0.00
2,400.00	0.00	0.00	2,400.00	0.00	0.00	0.00	0.00	0.00	0.00
2,500.00	0.00	0.00	2,500.00	0.00	0.00	0.00	0.00	0.00	0.00
2,600.00	0.00	0.00	2,600.00	0.00	0.00	0.00	0.00	0.00	0.00
2,700.00	0.00	0.00	2,700.00	0.00	0.00	0.00	0.00	0.00	0.00
2,800.00	0.00	0.00	2,800.00	0.00	0.00	0.00	0.00	0.00	0.00
2,900.00	0.00	0.00	2,900.00	0.00	0.00	0.00	0.00	0.00	0.00
3,000.00	0.00	0.00	3,000.00	0.00	0.00	0.00	0.00	0.00	0.00
3,100.00	0.00	0.00	3,100.00	0.00	0.00	0.00	0.00	0.00	0.00
3,200.00	0.00	0.00	3,200.00	0.00	0.00	0.00	0.00	0.00	0.00
3,300.00	0.00	0.00	3,300.00	0.00	0.00	0.00	0.00	0.00	0.00
3,400.00	0.00	0.00	3,400.00	0.00	0.00	0.00	0.00	0.00	0.00
3,500.00	0.00	0.00	3,500.00	0.00	0.00	0.00	0.00	0.00	0.00
3,600.00	0.00	0.00	3,600.00	0.00	0.00	0.00	0.00	0.00	0.00
3,700.00	0.00	0.00	3,700.00	0.00	0.00	0.00	0.00	0.00	0.00
3,800.00	0.00	0.00	3,800.00	0.00	0.00	0.00	0.00	0.00	0.00
3,900.00	0.00	0.00	3,900.00	0.00	0.00	0.00	0.00	0.00	0.00
4,000.00	0.00	0.00	4,000.00	0.00	0.00	0.00	0.00	0.00	0.00
4,100.00	0.00	0.00	4,100.00	0.00	0.00	0.00	0.00	0.00	0.00
4,200.00	0.00	0.00	4,200.00	0.00	0.00	0.00	0.00	0.00	0.00
4,300.00	0.00	0.00	4,300.00	0.00	0.00	0.00	0.00	0.00	0.00
4,400.00	0.00	0.00	4,400.00	0.00	0.00	0.00	0.00	0.00	0.00
4,500.00	0.00	0.00	4,500.00	0.00	0.00	0.00	0.00	0.00	0.00
4,600.00	0.00	0.00	4,600.00	0.00	0.00	0.00	0.00	0.00	0.00
4,700.00	0.00	0.00	4,700.00	0.00	0.00	0.00	0.00	0.00	0.00
4,800.00	0.00	0.00	4,800.00	0.00	0.00	0.00	0.00	0.00	0.00
4,900.00	0.00	0.00	4,900.00	0.00	0.00	0.00	0.00	0.00	0.00
5,000.00	0.00	0.00	5,000.00	0.00	0.00	0.00	0.00	0.00	0.00
5,100.00	0.00	0.00	5,100.00	0.00	0.00	0.00	0.00	0.00	0.00
5,200.00	0.00	0.00	5,200.00	0.00	0.00	0.00	0.00	0.00	0.00
5,300.00	0.00	0.00	5,300.00	0.00	0.00	0.00	0.00	0.00	0.00
5,400.00	0.00	0.00	5,400.00	0.00	0.00	0.00	0.00	0.00	0.00

OXY Planning Report

Database:	HOPSPP	Local Co-ordinate Reference:	Well Platinum MDP1 34_3 Fed Com 52H
Company:	ENGINEERING DESIGNS	TVD Reference:	RKB=25' @ 3445.00ft
Project:	PRD NM DIRECTIONAL PLANS (NAD 1983)	MD Reference:	RKB=25' @ 3445.00ft
Site:	PLATINUM MDP1 34-3 FED COM	North Reference:	Grid
Well:	Platinum MDP1 34_3 Fed Com 52H	Survey Calculation Method:	Minimum Curvature
Wellbore:	Wellbore #1		
Design:	Permitting Plan		

Planned Survey									
Measured Depth (ft)	Inclination (°)	Azimuth (°)	Vertical Depth (ft)	+N/-S (ft)	+E/-W (ft)	Vertical Section (ft)	Dogleg Rate (°/100ft)	Build Rate (°/100ft)	Turn Rate (°/100ft)
5,500.00	0.00	0.00	5,500.00	0.00	0.00	0.00	0.00	0.00	0.00
5,600.00	0.00	0.00	5,600.00	0.00	0.00	0.00	0.00	0.00	0.00
5,700.00	0.00	0.00	5,700.00	0.00	0.00	0.00	0.00	0.00	0.00
5,800.00	0.00	0.00	5,800.00	0.00	0.00	0.00	0.00	0.00	0.00
5,900.00	0.00	0.00	5,900.00	0.00	0.00	0.00	0.00	0.00	0.00
6,000.00	0.00	0.00	6,000.00	0.00	0.00	0.00	0.00	0.00	0.00
6,100.00	0.00	0.00	6,100.00	0.00	0.00	0.00	0.00	0.00	0.00
6,200.00	0.00	0.00	6,200.00	0.00	0.00	0.00	0.00	0.00	0.00
6,300.00	0.00	0.00	6,300.00	0.00	0.00	0.00	0.00	0.00	0.00
6,400.00	0.00	0.00	6,400.00	0.00	0.00	0.00	0.00	0.00	0.00
6,500.00	0.00	0.00	6,500.00	0.00	0.00	0.00	0.00	0.00	0.00
6,600.00	0.00	0.00	6,600.00	0.00	0.00	0.00	0.00	0.00	0.00
6,700.00	0.00	0.00	6,700.00	0.00	0.00	0.00	0.00	0.00	0.00
6,800.00	0.00	0.00	6,800.00	0.00	0.00	0.00	0.00	0.00	0.00
6,900.00	0.00	0.00	6,900.00	0.00	0.00	0.00	0.00	0.00	0.00
7,000.00	0.00	0.00	7,000.00	0.00	0.00	0.00	0.00	0.00	0.00
7,100.00	0.00	0.00	7,100.00	0.00	0.00	0.00	0.00	0.00	0.00
7,200.00	0.00	0.00	7,200.00	0.00	0.00	0.00	0.00	0.00	0.00
7,300.00	0.00	0.00	7,300.00	0.00	0.00	0.00	0.00	0.00	0.00
7,400.00	0.00	0.00	7,400.00	0.00	0.00	0.00	0.00	0.00	0.00
7,500.00	0.00	0.00	7,500.00	0.00	0.00	0.00	0.00	0.00	0.00
7,600.00	0.00	0.00	7,600.00	0.00	0.00	0.00	0.00	0.00	0.00
7,700.00	0.00	0.00	7,700.00	0.00	0.00	0.00	0.00	0.00	0.00
7,800.00	0.00	0.00	7,800.00	0.00	0.00	0.00	0.00	0.00	0.00
7,900.00	0.00	0.00	7,900.00	0.00	0.00	0.00	0.00	0.00	0.00
8,000.00	0.00	0.00	8,000.00	0.00	0.00	0.00	0.00	0.00	0.00
8,100.00	0.00	0.00	8,100.00	0.00	0.00	0.00	0.00	0.00	0.00
8,200.00	0.00	0.00	8,200.00	0.00	0.00	0.00	0.00	0.00	0.00
8,300.00	0.00	0.00	8,300.00	0.00	0.00	0.00	0.00	0.00	0.00
8,400.00	0.00	0.00	8,400.00	0.00	0.00	0.00	0.00	0.00	0.00
8,500.00	0.00	0.00	8,500.00	0.00	0.00	0.00	0.00	0.00	0.00
8,600.00	0.00	0.00	8,600.00	0.00	0.00	0.00	0.00	0.00	0.00
8,700.00	0.00	0.00	8,700.00	0.00	0.00	0.00	0.00	0.00	0.00
8,800.00	0.00	0.00	8,800.00	0.00	0.00	0.00	0.00	0.00	0.00
8,900.00	0.00	0.00	8,900.00	0.00	0.00	0.00	0.00	0.00	0.00
9,000.00	0.00	0.00	9,000.00	0.00	0.00	0.00	0.00	0.00	0.00
9,100.00	0.00	0.00	9,100.00	0.00	0.00	0.00	0.00	0.00	0.00
9,200.00	1.00	279.66	9,200.00	0.15	-0.86	-0.11	1.00	1.00	0.00
9,300.00	2.00	279.66	9,299.96	0.59	-3.44	-0.43	1.00	1.00	0.00
9,400.00	3.00	279.66	9,399.86	1.32	-7.74	-0.96	1.00	1.00	0.00
9,500.00	4.00	279.66	9,499.68	2.34	-13.76	-1.71	1.00	1.00	0.00
9,600.00	5.00	279.66	9,599.37	3.66	-21.49	-2.68	1.00	1.00	0.00
9,700.00	6.00	279.66	9,698.90	5.27	-30.94	-3.86	1.00	1.00	0.00
9,800.00	7.00	279.66	9,798.26	7.17	-42.10	-5.25	1.00	1.00	0.00
9,900.00	8.00	279.66	9,897.40	9.36	-54.97	-6.85	1.00	1.00	0.00
10,000.00	9.00	279.66	9,996.30	11.84	-69.54	-8.67	1.00	1.00	0.00
10,099.66	10.00	279.66	10,094.60	14.60	-85.75	-10.69	1.00	1.00	0.00
10,100.00	10.00	279.66	10,094.93	14.61	-85.81	-10.69	0.00	0.00	0.00
10,200.00	10.00	279.66	10,193.41	17.52	-102.92	-12.83	0.00	0.00	0.00
10,300.00	10.00	279.66	10,291.89	20.43	-120.04	-14.96	0.00	0.00	0.00
10,400.00	10.00	279.66	10,390.38	23.35	-137.15	-17.09	0.00	0.00	0.00
10,500.00	10.00	279.66	10,488.86	26.26	-154.26	-19.22	0.00	0.00	0.00
10,600.00	10.00	279.66	10,587.34	29.17	-171.37	-21.36	0.00	0.00	0.00
10,700.00	10.00	279.66	10,685.82	32.09	-188.49	-23.49	0.00	0.00	0.00
10,800.00	10.00	279.66	10,784.30	35.00	-205.60	-25.62	0.00	0.00	0.00

OXY

Planning Report

Database:	HOPSPP	Local Co-ordinate Reference:	Well Platinum MDP1 34_3 Fed Com 52H
Company:	ENGINEERING DESIGNS	TVD Reference:	RKB=25' @ 3445.00ft
Project:	PRD NM DIRECTIONAL PLANS (NAD 1983)	MD Reference:	RKB=25' @ 3445.00ft
Site:	PLATINUM MDP1 34-3 FED COM	North Reference:	Grid
Well:	Platinum MDP1 34_3 Fed Com 52H	Survey Calculation Method:	Minimum Curvature
Wellbore:	Wellbore #1		
Design:	Permitting Plan		

Planned Survey										
Measured Depth (ft)	Inclination (°)	Azimuth (°)	Vertical Depth (ft)	+N/-S (ft)	+E/-W (ft)	Vertical Section (ft)	Dogleg Rate (°/100ft)	Build Rate (°/100ft)	Turn Rate (°/100ft)	
10,900.00	10.00	279.66	10,882.79	37.91	-222.71	-27.76	0.00	0.00	0.00	
11,000.00	10.00	279.66	10,981.27	40.83	-239.83	-29.89	0.00	0.00	0.00	
11,100.00	10.00	279.66	11,079.75	43.74	-256.94	-32.02	0.00	0.00	0.00	
11,200.00	10.00	279.66	11,178.23	46.65	-274.05	-34.15	0.00	0.00	0.00	
11,300.00	10.00	279.66	11,276.71	49.57	-291.16	-36.29	0.00	0.00	0.00	
11,400.00	10.00	279.66	11,375.19	52.48	-308.28	-38.42	0.00	0.00	0.00	
11,500.00	10.00	279.66	11,473.68	55.39	-325.39	-40.55	0.00	0.00	0.00	
11,600.00	10.00	279.66	11,572.16	58.31	-342.50	-42.68	0.00	0.00	0.00	
11,700.00	10.00	279.66	11,670.64	61.22	-359.62	-44.82	0.00	0.00	0.00	
11,800.00	10.00	279.66	11,769.12	64.13	-376.73	-46.95	0.00	0.00	0.00	
11,900.00	10.00	279.66	11,867.60	67.05	-393.84	-49.08	0.00	0.00	0.00	
12,000.00	10.00	279.66	11,966.09	69.96	-410.95	-51.21	0.00	0.00	0.00	
12,053.34	10.00	279.66	12,018.61	71.51	-420.08	-52.35	0.00	0.00	0.00	
12,100.00	10.28	252.96	12,064.57	70.97	-428.06	-51.45	10.00	0.61	-57.21	
12,200.00	16.22	216.39	12,162.03	57.08	-444.92	-36.80	10.00	5.94	-36.58	
12,300.00	24.87	201.74	12,255.64	26.22	-461.04	-5.25	10.00	8.65	-14.65	
12,400.00	34.23	194.53	12,342.56	-20.66	-475.92	42.26	10.00	9.36	-7.21	
12,500.00	43.85	190.16	12,420.15	-82.14	-489.12	104.28	10.00	9.62	-4.37	
12,600.00	53.59	187.10	12,486.05	-156.36	-500.23	178.93	10.00	9.74	-3.05	
12,700.00	63.38	184.74	12,538.26	-241.05	-508.92	263.93	10.00	9.80	-2.37	
12,800.00	73.21	182.75	12,575.20	-333.65	-514.92	356.70	10.00	9.83	-1.99	
12,900.00	83.06	180.96	12,595.74	-431.34	-518.05	454.43	10.00	9.85	-1.79	
12,970.47	90.00	179.74	12,600.00	-501.63	-518.47	524.67	10.00	9.85	-1.72	
13,000.00	90.00	179.74	12,600.00	-531.16	-518.34	554.17	0.00	0.00	0.00	
13,100.00	90.00	179.74	12,600.00	-631.16	-517.90	654.04	0.00	0.00	0.00	
13,200.00	90.00	179.74	12,600.00	-731.16	-517.45	753.92	0.00	0.00	0.00	
13,300.00	90.00	179.74	12,600.00	-831.16	-517.00	853.79	0.00	0.00	0.00	
13,400.00	90.00	179.74	12,600.00	-931.16	-516.56	953.67	0.00	0.00	0.00	
13,500.00	90.00	179.74	12,600.00	-1,031.16	-516.11	1,053.55	0.00	0.00	0.00	
13,600.00	90.00	179.74	12,600.00	-1,131.16	-515.67	1,153.42	0.00	0.00	0.00	
13,700.00	90.00	179.74	12,600.00	-1,231.16	-515.22	1,253.30	0.00	0.00	0.00	
13,800.00	90.00	179.74	12,600.00	-1,331.16	-514.77	1,353.17	0.00	0.00	0.00	
13,900.00	90.00	179.74	12,600.00	-1,431.16	-514.33	1,453.05	0.00	0.00	0.00	
14,000.00	90.00	179.74	12,600.00	-1,531.15	-513.88	1,552.92	0.00	0.00	0.00	
14,100.00	90.00	179.74	12,600.00	-1,631.15	-513.44	1,652.80	0.00	0.00	0.00	
14,200.00	90.00	179.74	12,600.00	-1,731.15	-512.99	1,752.67	0.00	0.00	0.00	
14,300.00	90.00	179.74	12,600.00	-1,831.15	-512.54	1,852.55	0.00	0.00	0.00	
14,400.00	90.00	179.74	12,600.00	-1,931.15	-512.10	1,952.42	0.00	0.00	0.00	
14,500.00	90.00	179.74	12,600.00	-2,031.15	-511.65	2,052.30	0.00	0.00	0.00	
14,600.00	90.00	179.74	12,600.00	-2,131.15	-511.21	2,152.18	0.00	0.00	0.00	
14,700.00	90.00	179.74	12,600.00	-2,231.15	-510.76	2,252.05	0.00	0.00	0.00	
14,800.00	90.00	179.74	12,600.00	-2,331.15	-510.31	2,351.93	0.00	0.00	0.00	
14,900.00	90.00	179.74	12,600.00	-2,431.15	-509.87	2,451.80	0.00	0.00	0.00	
15,000.00	90.00	179.74	12,600.00	-2,531.14	-509.42	2,551.68	0.00	0.00	0.00	
15,100.00	90.00	179.74	12,600.00	-2,631.14	-508.98	2,651.55	0.00	0.00	0.00	
15,200.00	90.00	179.74	12,600.00	-2,731.14	-508.53	2,751.43	0.00	0.00	0.00	
15,300.00	90.00	179.74	12,600.00	-2,831.14	-508.08	2,851.30	0.00	0.00	0.00	
15,400.00	90.00	179.74	12,600.00	-2,931.14	-507.64	2,951.18	0.00	0.00	0.00	
15,500.00	90.00	179.74	12,600.00	-3,031.14	-507.19	3,051.05	0.00	0.00	0.00	
15,600.00	90.00	179.74	12,600.00	-3,131.14	-506.74	3,150.93	0.00	0.00	0.00	
15,700.00	90.00	179.74	12,600.00	-3,231.14	-506.30	3,250.81	0.00	0.00	0.00	
15,800.00	90.00	179.74	12,600.00	-3,331.14	-505.85	3,350.68	0.00	0.00	0.00	
15,900.00	90.00	179.74	12,600.00	-3,431.14	-505.41	3,450.56	0.00	0.00	0.00	
16,000.00	90.00	179.74	12,600.00	-3,531.13	-504.96	3,550.43	0.00	0.00	0.00	
16,100.00	90.00	179.74	12,600.00	-3,631.13	-504.51	3,650.31	0.00	0.00	0.00	

OXY Planning Report

Database:	HOPSPP	Local Co-ordinate Reference:	Well Platinum MDP1 34_3 Fed Com 52H
Company:	ENGINEERING DESIGNS	TVD Reference:	RKB=25' @ 3445.00ft
Project:	PRD NM DIRECTIONAL PLANS (NAD 1983)	MD Reference:	RKB=25' @ 3445.00ft
Site:	PLATINUM MDP1 34-3 FED COM	North Reference:	Grid
Well:	Platinum MDP1 34_3 Fed Com 52H	Survey Calculation Method:	Minimum Curvature
Wellbore:	Wellbore #1		
Design:	Permitting Plan		

Planned Survey									
Measured Depth (ft)	Inclination (°)	Azimuth (°)	Vertical Depth (ft)	+N/-S (ft)	+E/-W (ft)	Vertical Section (ft)	Dogleg Rate (°/100ft)	Build Rate (°/100ft)	Turn Rate (°/100ft)
16,200.00	90.00	179.74	12,600.00	-3,731.13	-504.07	3,750.18	0.00	0.00	0.00
16,300.00	90.00	179.74	12,600.00	-3,831.13	-503.62	3,850.06	0.00	0.00	0.00
16,400.00	90.00	179.74	12,600.00	-3,931.13	-503.18	3,949.93	0.00	0.00	0.00
16,500.00	90.00	179.74	12,600.00	-4,031.13	-502.73	4,049.81	0.00	0.00	0.00
16,600.00	90.00	179.74	12,600.00	-4,131.13	-502.28	4,149.68	0.00	0.00	0.00
16,700.00	90.00	179.74	12,600.00	-4,231.13	-501.84	4,249.56	0.00	0.00	0.00
16,800.00	90.00	179.74	12,600.00	-4,331.13	-501.39	4,349.44	0.00	0.00	0.00
16,900.00	90.00	179.74	12,600.00	-4,431.13	-500.95	4,449.31	0.00	0.00	0.00
17,000.00	90.00	179.74	12,600.00	-4,531.12	-500.50	4,549.19	0.00	0.00	0.00
17,100.00	90.00	179.74	12,600.00	-4,631.12	-500.05	4,649.06	0.00	0.00	0.00
17,200.00	90.00	179.74	12,600.00	-4,731.12	-499.61	4,748.94	0.00	0.00	0.00
17,300.00	90.00	179.74	12,600.00	-4,831.12	-499.16	4,848.81	0.00	0.00	0.00
17,400.00	90.00	179.74	12,600.00	-4,931.12	-498.72	4,948.69	0.00	0.00	0.00
17,500.00	90.00	179.74	12,600.00	-5,031.12	-498.27	5,048.56	0.00	0.00	0.00
17,600.00	90.00	179.74	12,600.00	-5,131.12	-497.82	5,148.44	0.00	0.00	0.00
17,700.00	90.00	179.74	12,600.00	-5,231.12	-497.38	5,248.31	0.00	0.00	0.00
17,800.00	90.00	179.74	12,600.00	-5,331.12	-496.93	5,348.19	0.00	0.00	0.00
17,900.00	90.00	179.74	12,600.00	-5,431.12	-496.49	5,448.07	0.00	0.00	0.00
18,000.00	90.00	179.74	12,600.00	-5,531.11	-496.04	5,547.94	0.00	0.00	0.00
18,100.00	90.00	179.74	12,600.00	-5,631.11	-495.59	5,647.82	0.00	0.00	0.00
18,200.00	90.00	179.74	12,600.00	-5,731.11	-495.15	5,747.69	0.00	0.00	0.00
18,300.00	90.00	179.74	12,600.00	-5,831.11	-494.70	5,847.57	0.00	0.00	0.00
18,400.00	90.00	179.74	12,600.00	-5,931.11	-494.26	5,947.44	0.00	0.00	0.00
18,500.00	90.00	179.74	12,600.00	-6,031.11	-493.81	6,047.32	0.00	0.00	0.00
18,600.00	90.00	179.74	12,600.00	-6,131.11	-493.36	6,147.19	0.00	0.00	0.00
18,700.00	90.00	179.74	12,600.00	-6,231.11	-492.92	6,247.07	0.00	0.00	0.00
18,800.00	90.00	179.74	12,600.00	-6,331.11	-492.47	6,346.94	0.00	0.00	0.00
18,900.00	90.00	179.74	12,600.00	-6,431.11	-492.02	6,446.82	0.00	0.00	0.00
19,000.00	90.00	179.74	12,600.00	-6,531.10	-491.58	6,546.70	0.00	0.00	0.00
19,100.00	90.00	179.74	12,600.00	-6,631.10	-491.13	6,646.57	0.00	0.00	0.00
19,200.00	90.00	179.74	12,600.00	-6,731.10	-490.69	6,746.45	0.00	0.00	0.00
19,300.00	90.00	179.74	12,600.00	-6,831.10	-490.24	6,846.32	0.00	0.00	0.00
19,400.00	90.00	179.74	12,600.00	-6,931.10	-489.79	6,946.20	0.00	0.00	0.00
19,500.00	90.00	179.74	12,600.00	-7,031.10	-489.35	7,046.07	0.00	0.00	0.00
19,600.00	90.00	179.74	12,600.00	-7,131.10	-488.90	7,145.95	0.00	0.00	0.00
19,700.00	90.00	179.74	12,600.00	-7,231.10	-488.46	7,245.82	0.00	0.00	0.00
19,800.00	90.00	179.74	12,600.00	-7,331.10	-488.01	7,345.70	0.00	0.00	0.00
19,900.00	90.00	179.74	12,600.00	-7,431.10	-487.56	7,445.57	0.00	0.00	0.00
20,000.00	90.00	179.74	12,600.00	-7,531.09	-487.12	7,545.45	0.00	0.00	0.00
20,100.00	90.00	179.74	12,600.00	-7,631.09	-486.67	7,645.33	0.00	0.00	0.00
20,200.00	90.00	179.74	12,600.00	-7,731.09	-486.23	7,745.20	0.00	0.00	0.00
20,300.00	90.00	179.74	12,600.00	-7,831.09	-485.78	7,845.08	0.00	0.00	0.00
20,400.00	90.00	179.74	12,600.00	-7,931.09	-485.33	7,944.95	0.00	0.00	0.00
20,500.00	90.00	179.74	12,600.00	-8,031.09	-484.89	8,044.83	0.00	0.00	0.00
20,600.00	90.00	179.74	12,600.00	-8,131.09	-484.44	8,144.70	0.00	0.00	0.00
20,700.00	90.00	179.74	12,600.00	-8,231.09	-484.00	8,244.58	0.00	0.00	0.00
20,800.00	90.00	179.74	12,600.00	-8,331.09	-483.55	8,344.45	0.00	0.00	0.00
20,900.00	90.00	179.74	12,600.00	-8,431.09	-483.10	8,444.33	0.00	0.00	0.00
21,000.00	90.00	179.74	12,600.00	-8,531.08	-482.66	8,544.20	0.00	0.00	0.00
21,100.00	90.00	179.74	12,600.00	-8,631.08	-482.21	8,644.08	0.00	0.00	0.00
21,200.00	90.00	179.74	12,600.00	-8,731.08	-481.77	8,743.96	0.00	0.00	0.00
21,300.00	90.00	179.74	12,600.00	-8,831.08	-481.32	8,843.83	0.00	0.00	0.00
21,400.00	90.00	179.74	12,600.00	-8,931.08	-480.87	8,943.71	0.00	0.00	0.00
21,500.00	90.00	179.74	12,600.00	-9,031.08	-480.43	9,043.58	0.00	0.00	0.00
21,600.00	90.00	179.74	12,600.00	-9,131.08	-479.98	9,143.46	0.00	0.00	0.00

OXY Planning Report

Database:	HOPSPP	Local Co-ordinate Reference:	Well Platinum MDP1 34_3 Fed Com 52H
Company:	ENGINEERING DESIGNS	TVD Reference:	RKB=25' @ 3445.00ft
Project:	PRD NM DIRECTIONAL PLANS (NAD 1983)	MD Reference:	RKB=25' @ 3445.00ft
Site:	PLATINUM MDP1 34-3 FED COM	North Reference:	Grid
Well:	Platinum MDP1 34_3 Fed Com 52H	Survey Calculation Method:	Minimum Curvature
Wellbore:	Wellbore #1		
Design:	Permitting Plan		

Planned Survey										
Measured Depth (ft)	Inclination (°)	Azimuth (°)	Vertical Depth (ft)	+N/-S (ft)	+E/-W (ft)	Vertical Section (ft)	Dogleg Rate (°/100ft)	Build Rate (°/100ft)	Turn Rate (°/100ft)	
21,700.00	90.00	179.74	12,600.00	-9,231.08	-479.54	9,243.33	0.00	0.00	0.00	
21,800.00	90.00	179.74	12,600.00	-9,331.08	-479.09	9,343.21	0.00	0.00	0.00	
21,900.00	90.00	179.74	12,600.00	-9,431.08	-478.64	9,443.08	0.00	0.00	0.00	
22,000.00	90.00	179.74	12,600.00	-9,531.07	-478.20	9,542.96	0.00	0.00	0.00	
22,100.00	90.00	179.74	12,600.00	-9,631.07	-477.75	9,642.83	0.00	0.00	0.00	
22,200.00	90.00	179.74	12,600.00	-9,731.07	-477.31	9,742.71	0.00	0.00	0.00	
22,300.00	90.00	179.74	12,600.00	-9,831.07	-476.86	9,842.59	0.00	0.00	0.00	
22,400.00	90.00	179.74	12,600.00	-9,931.07	-476.41	9,942.46	0.00	0.00	0.00	
22,500.00	90.00	179.74	12,600.00	-10,031.07	-475.97	10,042.34	0.00	0.00	0.00	
22,600.00	90.00	179.74	12,600.00	-10,131.07	-475.52	10,142.21	0.00	0.00	0.00	
22,700.00	90.00	179.74	12,600.00	-10,231.07	-475.07	10,242.09	0.00	0.00	0.00	
22,800.00	90.00	179.74	12,600.00	-10,331.07	-474.63	10,341.96	0.00	0.00	0.00	
22,894.47	90.00	179.74	12,600.00	-10,425.53	-474.21	10,436.31	0.00	0.00	0.00	

Design Targets										
Target Name	Dip Angle (°)	Dip Dir. (°)	TVD (ft)	+N/-S (ft)	+E/-W (ft)	Northing (usft)	Easting (usft)	Latitude	Longitude	
KOP (Platinum MDP1 - hit/miss target - Shape - plan misses target center by 526.05ft at 0.00ft MD (0.00 TVD, 0.00 N, 0.00 E) - Point	0.00	0.00	0.00	72.13	-521.08	461,705.74	715,496.20	32.268047	-103.769868	
PBHL (Platinum MDP1 - plan hits target center - Point	0.00	0.00	12,600.00	-10,425.53	-474.21	451,208.68	715,543.07	32.239192	-103.769895	
FTP (Platinum MDP1 - plan misses target center by 203.33ft at 12544.78ft MD (12451.23 TVD, -113.93 N, -494.37 E) - Point	0.00	0.00	12,600.00	22.13	-520.81	461,655.74	715,496.47	32.267910	-103.769868	

Formations						
Measured Depth (ft)	Vertical Depth (ft)	Name	Lithology	Dip (°)	Dip Direction (°)	
553.00	553.00	RUSTLER				
883.00	883.00	SALADO				
2,832.00	2,832.00	CASTILE				
4,306.00	4,306.00	DELAWARE				
4,334.00	4,334.00	BELL CANYON				
5,219.00	5,219.00	CHERRY CANYON				
6,481.00	6,481.00	BRUSHY CANYON				
8,146.00	8,146.00	BONE SPRING				
9,207.01	9,207.00	BONE SPRING 1ST				
9,804.78	9,803.00	BONE SPRING 2ND				
11,040.35	11,021.00	BONE SPRING 3RD				
11,503.38	11,477.00	WOLFCAMP				
11,651.63	11,623.00	WOLFCAMP A				

OXY
Planning Report

Database:	HOPSPP	Local Co-ordinate Reference:	Well Platinum MDP1 34_3 Fed Com 52H
Company:	ENGINEERING DESIGNS	TVD Reference:	RKB=25' @ 3445.00ft
Project:	PRD NM DIRECTIONAL PLANS (NAD 1983)	MD Reference:	RKB=25' @ 3445.00ft
Site:	PLATINUM MDP1 34-3 FED COM	North Reference:	Grid
Well:	Platinum MDP1 34_3 Fed Com 52H	Survey Calculation Method:	Minimum Curvature
Wellbore:	Wellbore #1		
Design:	Permitting Plan		

Plan Annotations				
Measured Depth (ft)	Vertical Depth (ft)	Local Coordinates		Comment
		+N/-S (ft)	+E/-W (ft)	
9,100.00	9,100.00	0.00	0.00	Build 1°/100'
10,099.66	10,094.60	14.60	-85.75	Hold 10° Tangent
12,053.34	12,018.61	71.51	-420.08	KOP, Build & Turn 10°/100'
12,970.47	12,600.00	-501.63	-518.47	Landing Point
22,894.47	12,600.00	-10,425.53	-474.21	TD at 22894.47' MD

Revision Date – May 21, 2024

4-String Design – Open Int 1 x Int 2 Annulus

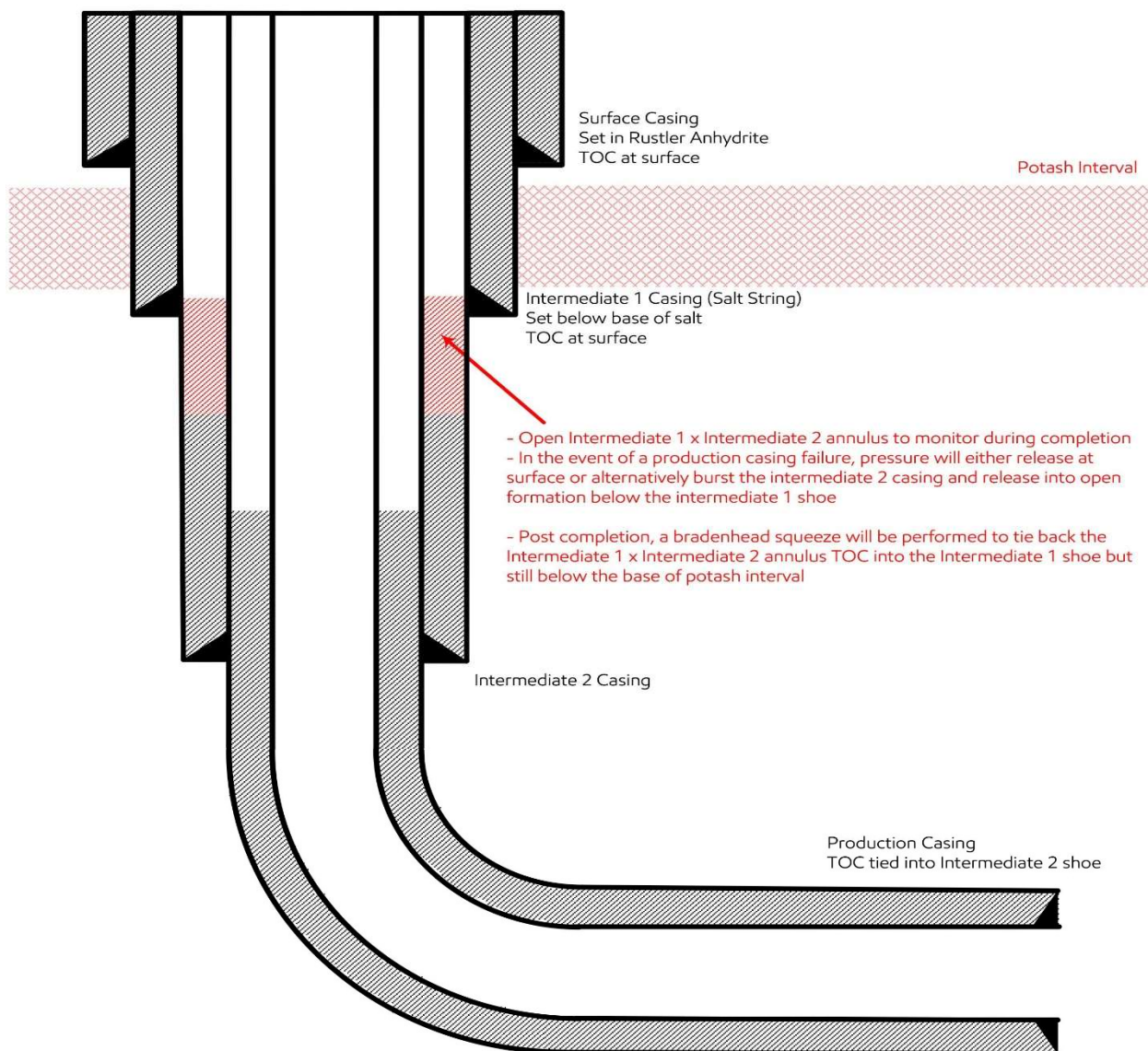
**Update May 2024:**

OXY is aware of the R111-Q update and will comply with these requirements including (but not limited to):

- 1) Alignment with KPLA requirements per schematic above, leaving open annulus for pressure monitoring during frac and utilizing new casing that meets API standards
- 2) Contingency plans in place to divert formation fluids away from salt interval in event of production casing failure
- 3) Bradenhead squeeze to be completed within 180days to tie back TOC to salt string at least 500ft but with top below Marker Bed 126
- 4) Production cement to be tied back no less than 500ft inside previous casing shoe
- 5) While drilling salt interval, separation distance to any active/inactive producing offset well will be ensured such that $SF > 1.0$; Anti-Collision Reports will be provided with APD Packages for review where $SF < 1.5$ against any applicable offset well, or where center-to-center separation against a blind or inclination only surveyed offset well is less than 500ft

Revision Date – May 21, 2024

3-String Design – Open Production Casing Annulus

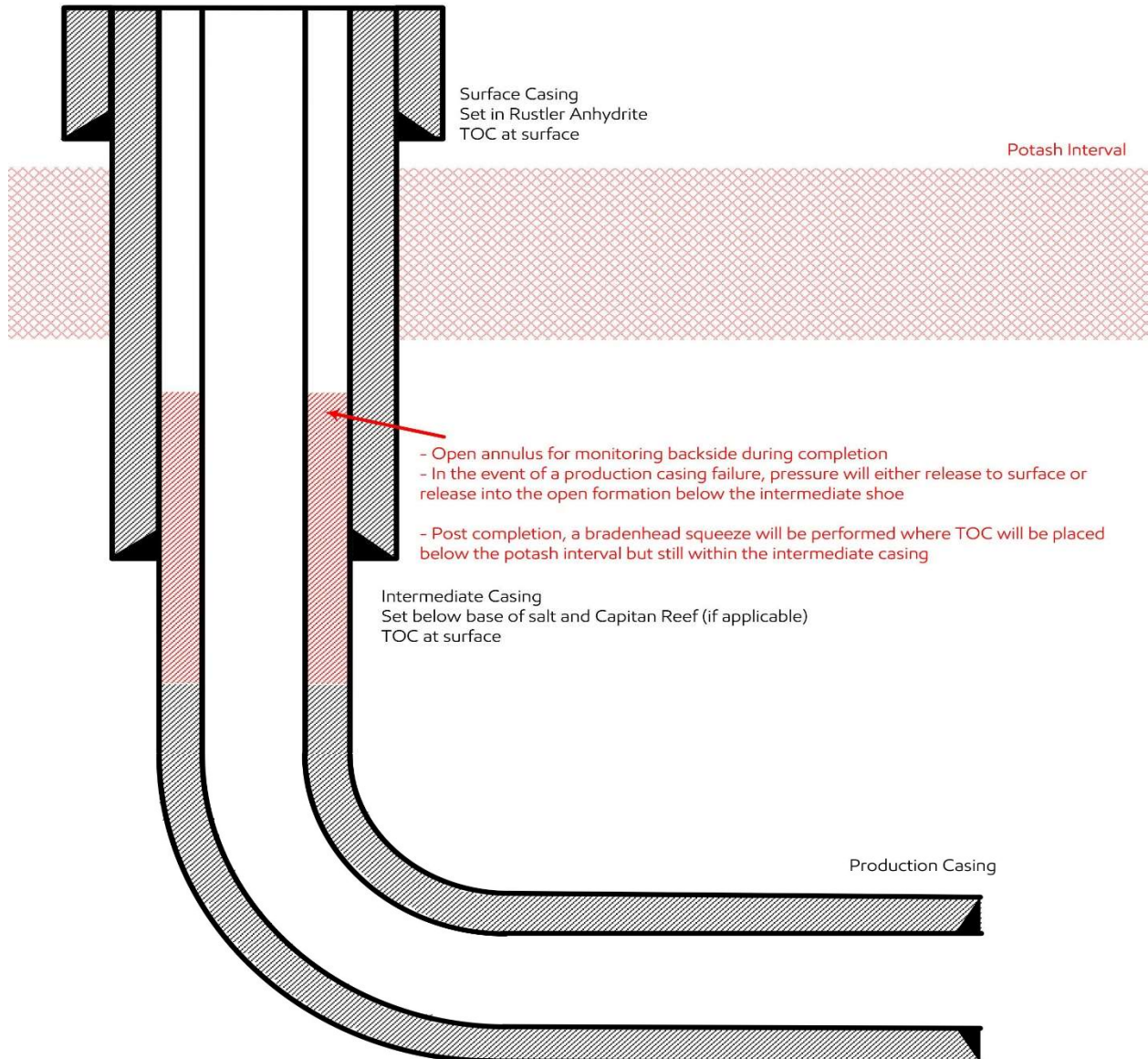

Update May 2024:

OXY is aware of the R111-Q update and will comply with these requirements including (but not limited to):

- 1) Alignment with KPLA requirements per schematic above, leaving open annulus for pressure monitoring during frac and utilizing new casing that meets API standards
- 2) Contingency plans in place to divert formation fluids away from salt interval in event of production casing failure
- 3) Bradenhead squeeze for Production cement to be completed within 180days to tie back TOC to previous casing string at least 500ft but with top below Marker Bed 126
- 4) While drilling salt interval, separation distance to any active/inactive producing offset well will be ensured such that $SF > 1.0$; Anti-Collision Reports will be provided with APD Packages for review where $SF < 1.5$ against any applicable offset well, or where center-to-center separation against a blind or inclination only surveyed offset well is less than 500ft

OXY USA Inc
APD ATTACHMENT: SPUDDER RIG DATA

OPERATOR NAME / NUMBER: OXY USA Inc

1. SUMMARY OF REQUEST:

Oxy USA respectfully requests approval for the following operations for the surface hole in the drill plan:

1. Utilize a spudder rig to pre-set surface casing for time and cost savings.

2. Description of Operations

1. Spudder rig will move in to drill the surface hole and pre-set surface casing on the well.
 - a. After drilling the surface hole section, the spudder rig will run casing and cement following all of the applicable rules and regulations (43 CFR part 3170 Subpart 3172, all COAs and NMOCD regulations).
 - b. The spudder rig will utilize fresh water-based mud to drill the surface hole to TD. Solids control will be handled entirely on a closed loop basis. No earth pits will be used.
2. The wellhead will be installed and tested as soon as the surface casing is cut off and the WOC time has been reached.
3. A blind flange at the same pressure rating as the wellhead will be installed to seal the wellbore. Pressure will be monitored with needle valves installed on two wingvalves.
 - a. A means for intervention will be maintained while the drilling rig is not over the well.
4. Spudder rig operations are expected to take 2-3 days per well on the pad.
5. The BLM will be contacted and notified 24 hours prior to commencing spudder rig operations.
6. Drilling operations will begin with a larger rig and a BOP stack equal to or greater than the pressure rating that was permitted will be nipped up and tested on the wellhead before drilling operations resume on each well.
 - a. The larger rig will move back onto the location within 90 days from the point at which the wells are secured and the spudder rig is moved off location.
 - b. The BLM will be contacted / notified 24 hours before the larger rig moves back on the pre-set locations.
7. Oxy will have supervision on the rig to ensure compliance with all BLM and NMOCD regulations and to oversee operations.
8. Once the rig is removed, Oxy will secure the wellhead area by placing a guard rail around the cellar area.

Spudder Rig Layout

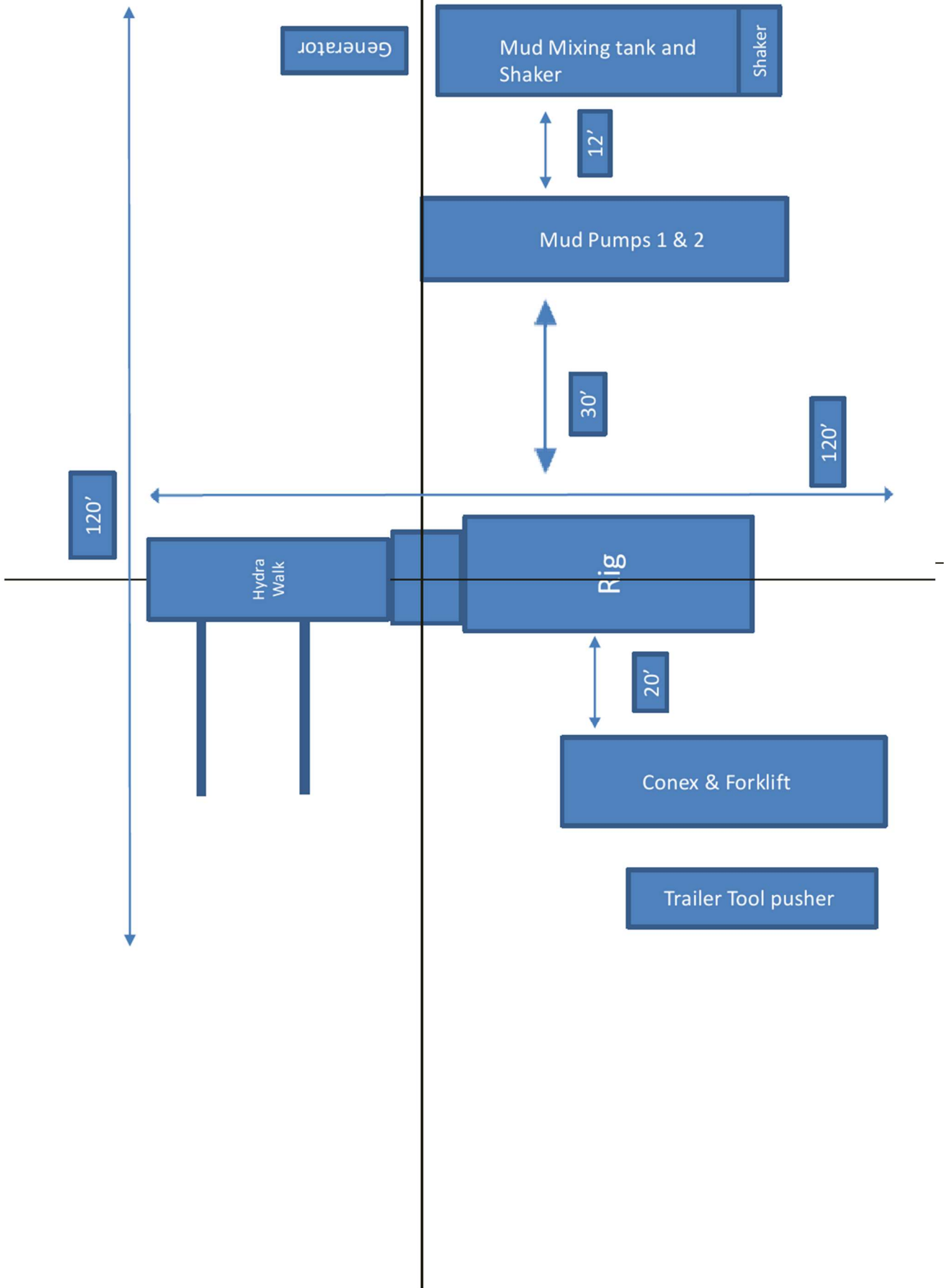

State of New Mexico
Energy, Minerals and Natural Resources Department

Submit Electronically
Via E-permitting

Oil Conservation Division
1220 South St. Francis Dr.
Santa Fe, NM 87505

NATURAL GAS MANAGEMENT PLAN

This Natural Gas Management Plan must be submitted with each Application for Permit to Drill (APD) for a new or recompleted well.

Section 1 – Plan Description

Effective May 25, 2021

I. Operator: OXY USA INC. **OGRID:** 16696 **Date:** 0 6/ 2 4/ 2 5

II. Type: Original Amendment due to 19.15.27.9.D(6)(a) NMAC 19.15.27.9.D(6)(b) NMAC Other.

If Other, please describe: _____

III. Well(s): Provide the following information for each new or recompleted well or set of wells proposed to be drilled or proposed to be recompleted from a single well pad or connected to a central delivery point.

Well Name	API	ULSTR	Footages	Anticipated Oil BBL/D	Anticipated Gas MCF/D	Anticipated Produced Water BBL/D
SEE ATTACHED						

IV. Central Delivery Point Name: PLATINUM CTB [See 19.15.27.9(D)(1) NMAC]

V. Anticipated Schedule: Provide the following information for each new or recompleted well or set of wells proposed to be drilled or proposed to be recompleted from a single well pad or connected to a central delivery point.

Well Name	API	Spud Date	TD Reached Date	Completion Commencement Date	Initial Flow Back Date	First Production Date
SEE ATTACHED						

VI. Separation Equipment: Attach a complete description of how Operator will size separation equipment to optimize gas capture.

VII. Operational Practices: Attach a complete description of the actions Operator will take to comply with the requirements of Subsection A through F of 19.15.27.8 NMAC.

VIII. Best Management Practices: Attach a complete description of Operator’s best management practices to minimize venting during active and planned maintenance.

Section 2 – Enhanced Plan
EFFECTIVE APRIL 1, 2022

Beginning April 1, 2022, an operator that is not in compliance with its statewide natural gas capture requirement for the applicable reporting area must complete this section.

Operator certifies that it is not required to complete this section because Operator is in compliance with its statewide natural gas capture requirement for the applicable reporting area.

IX. Anticipated Natural Gas Production:

Well	API	Anticipated Average Natural Gas Rate MCF/D	Anticipated Volume of Natural Gas for the First Year MCF

X. Natural Gas Gathering System (NGGS):

Operator	System	ULSTR of Tie-in	Anticipated Gathering Start Date	Available Maximum Daily Capacity of System Segment Tie-in

XI. Map. Attach an accurate and legible map depicting the location of the well(s), the anticipated pipeline route(s) connecting the production operations to the existing or planned interconnect of the natural gas gathering system(s), and the maximum daily capacity of the segment or portion of the natural gas gathering system(s) to which the well(s) will be connected.

XII. Line Capacity. The natural gas gathering system will will not have capacity to gather 100% of the anticipated natural gas production volume from the well prior to the date of first production.

XIII. Line Pressure. Operator does does not anticipate that its existing well(s) connected to the same segment, or portion, of the natural gas gathering system(s) described above will continue to meet anticipated increases in line pressure caused by the new well(s).

Attach Operator’s plan to manage production in response to the increased line pressure.

XIV. Confidentiality: Operator asserts confidentiality pursuant to Section 71-2-8 NMSA 1978 for the information provided in Section 2 as provided in Paragraph (2) of Subsection D of 19.15.27.9 NMAC, and attaches a full description of the specific information for which confidentiality is asserted and the basis for such assertion.

Section 3 - Certifications

Effective May 25, 2021

Operator certifies that, after reasonable inquiry and based on the available information at the time of submittal:

Operator will be able to connect the well(s) to a natural gas gathering system in the general area with sufficient capacity to transport one hundred percent of the anticipated volume of natural gas produced from the well(s) commencing on the date of first production, taking into account the current and anticipated volumes of produced natural gas from other wells connected to the pipeline gathering system; or

Operator will not be able to connect to a natural gas gathering system in the general area with sufficient capacity to transport one hundred percent of the anticipated volume of natural gas produced from the well(s) commencing on the date of first production, taking into account the current and anticipated volumes of produced natural gas from other wells connected to the pipeline gathering system.

If Operator checks this box, Operator will select one of the following:

Well Shut-In. Operator will shut-in and not produce the well until it submits the certification required by Paragraph (4) of Subsection D of 19.15.27.9 NMAC; or

Venting and Flaring Plan. Operator has attached a venting and flaring plan that evaluates and selects one or more of the potential alternative beneficial uses for the natural gas until a natural gas gathering system is available, including:

- (a) power generation on lease;
- (b) power generation for grid;
- (c) compression on lease;
- (d) liquids removal on lease;
- (e) reinjection for underground storage;
- (f) reinjection for temporary storage;
- (g) reinjection for enhanced oil recovery;
- (h) fuel cell production; and
- (i) other alternative beneficial uses approved by the division.

Section 4 - Notices

1. If, at any time after Operator submits this Natural Gas Management Plan and before the well is spud:

(a) Operator becomes aware that the natural gas gathering system it planned to connect the well(s) to has become unavailable or will not have capacity to transport one hundred percent of the production from the well(s), no later than 20 days after becoming aware of such information, Operator shall submit for OCD's approval a new or revised venting and flaring plan containing the information specified in Paragraph (5) of Subsection D of 19.15.27.9 NMAC; or

(b) Operator becomes aware that it has, cumulatively for the year, become out of compliance with its baseline natural gas capture rate or natural gas capture requirement, no later than 20 days after becoming aware of such information, Operator shall submit for OCD's approval a new or revised Natural Gas Management Plan for each well it plans to spud during the next 90 days containing the information specified in Paragraph (2) of Subsection D of 19.15.27.9 NMAC, and shall file an update for each Natural Gas Management Plan until Operator is back in compliance with its baseline natural gas capture rate or natural gas capture requirement.

2. OCD may deny or conditionally approve an APD if Operator does not make a certification, fails to submit an adequate venting and flaring plan which includes alternative beneficial uses for the anticipated volume of natural gas produced, or if OCD determines that Operator will not have adequate natural gas takeaway capacity at the time a well will be spud.

Page 8

I certify that, after reasonable inquiry, the statements in and attached to this Natural Gas Management Plan are true and correct to the best of my knowledge and acknowledge that a false statement may be subject to civil and criminal penalties under the Oil and Gas Act.

Signature: <i>Roni Mathew</i>
Printed Name: Roni Mathew
Title: Regulatory Advisor
E-mail Address: roni_mathew@oxy.com
Date: 06/24/2025
Phone: 713-215-7827
OIL CONSERVATION DIVISION (Only applicable when submitted as a standalone form)
Approved By:
Title:
Approval Date:
Conditions of Approval:

III. Well(s)

Well Name	API	WELL LOCATION (ULSTR)	Footages	ANTICIPATED OIL BBL/D	ANTICIPATED GAS MCF/D	ANTICIPATED PROD WATER BBL/D
PLATINUM MDP1 34_3 FED COM 11H	Pending	C-34-23S-31E	124' FNL 1712' FWL	1600	2275	3375
PLATINUM MDP1 34_3 FED COM 12H	Pending	C-34-23S-31E	125' FNL 1772' FWL	2330	9500	5750
PLATINUM MDP1 34_3 FED COM 21H	Pending	C-34-23S-31E	124' FNL 1682' FWL	2330	9500	5750
PLATINUM MDP1 34_3 FED COM 22H	Pending	C-34-23S-31E	125' FNL 1742' FWL	2330	9500	5750
PLATINUM MDP1 34_3 FED COM 41H	Pending	C-34-23S-31E	125' FNL 1832' FWL	2240	11300	10000
PLATINUM MDP1 34_3 FED COM 42H	Pending	C-34-23S-31E	250' FNL 1831' FWL	2240	11300	10000
PLATINUM MDP1 34_3 FED COM 43H	Pending	C-34-23S-31E	1177' FNL 2477' FWL	2240	11300	10000
PLATINUM MDP1 34_3 FED COM 44H	Pending	A-34-23S-31E	111' FNL 863' FEL	2240	11300	10000
PLATINUM MDP1 34_3 FED COM 45H	Pending	C-34-23S-31E	1177' FNL 2537' FWL	2240	11300	10000
PLATINUM MDP1 34_3 FED COM 51H	Pending	C-34-23S-31E	250' FNL 1801' FWL	2240	11300	10000
PLATINUM MDP1 34_3 FED COM 52H	Pending	C-34-23S-31E	125' FNL 1862' FWL	2240	11300	10000
PLATINUM MDP1 34_3 FED COM 53H	Pending	C-34-23S-31E	250' FNL 1861' FWL	2240	11300	10000
PLATINUM MDP1 34_3 FED COM 54H	Pending	C-34-23S-31E	1177' FNL 2507' FWL	2240	11300	10000
PLATINUM MDP1 34_3 FED COM 55H	Pending	A-34-23S-31E	111' FNL 828' FEL	2240	11300	10000
PLATINUM MDP1 34_3 FED COM 71H	Pending	C-34-23S-31E	249' FNL 1681' FWL	2160	3600	3350
PLATINUM MDP1 34_3 FED COM 72H	Pending	C-34-23S-31E	249' FNL 1711' FWL	2160	3600	3350
PLATINUM MDP1 34_3 FED COM 73H	Pending	C-34-23S-31E	249' FNL 1741' FWL	2160	3600	3350
PLATINUM MDP1 34_3 FED COM 74H	Pending	H-34-23S-31E	1330' FNL 927' FEL	2160	3600	3350
PLATINUM MDP1 34_3 FED COM 75H	Pending	H-34-23S-31E	1330' FNL 897' FEL	2160	3600	3350
PLATINUM MDP1 34_3 FED COM 76H	Pending	H-34-23S-31E	1330' FNL 867' FEL	2160	3600	3350

V. Anticipated Schedule

Well Name	API	Spud Date	TD Reached Date	Completion Commencement Date	Initial Flow Back Date	First Production Date
PLATINUM MDP1 34_3 FED COM 11H	Pending	TBD	TBD	TBD	TBD	TBD
PLATINUM MDP1 34_3 FED COM 12H	Pending	TBD	TBD	TBD	TBD	TBD
PLATINUM MDP1 34_3 FED COM 21H	Pending	TBD	TBD	TBD	TBD	TBD
PLATINUM MDP1 34_3 FED COM 22H	Pending	TBD	TBD	TBD	TBD	TBD
PLATINUM MDP1 34_3 FED COM 41H	Pending	TBD	TBD	TBD	TBD	TBD
PLATINUM MDP1 34_3 FED COM 42H	Pending	TBD	TBD	TBD	TBD	TBD
PLATINUM MDP1 34_3 FED COM 43H	Pending	TBD	TBD	TBD	TBD	TBD
PLATINUM MDP1 34_3 FED COM 44H	Pending	TBD	TBD	TBD	TBD	TBD
PLATINUM MDP1 34_3 FED COM 45H	Pending	TBD	TBD	TBD	TBD	TBD
PLATINUM MDP1 34_3 FED COM 51H	Pending	TBD	TBD	TBD	TBD	TBD
PLATINUM MDP1 34_3 FED COM 52H	Pending	TBD	TBD	TBD	TBD	TBD
PLATINUM MDP1 34_3 FED COM 53H	Pending	TBD	TBD	TBD	TBD	TBD
PLATINUM MDP1 34_3 FED COM 54H	Pending	TBD	TBD	TBD	TBD	TBD
PLATINUM MDP1 34_3 FED COM 55H	Pending	TBD	TBD	TBD	TBD	TBD
PLATINUM MDP1 34_3 FED COM 71H	Pending	TBD	TBD	TBD	TBD	TBD
PLATINUM MDP1 34_3 FED COM 72H	Pending	TBD	TBD	TBD	TBD	TBD
PLATINUM MDP1 34_3 FED COM 73H	Pending	TBD	TBD	TBD	TBD	TBD
PLATINUM MDP1 34_3 FED COM 74H	Pending	TBD	TBD	TBD	TBD	TBD
PLATINUM MDP1 34_3 FED COM 75H	Pending	TBD	TBD	TBD	TBD	TBD
PLATINUM MDP1 34_3 FED COM 76H	Pending	TBD	TBD	TBD	TBD	TBD

Central Delivery Point Name : PLATINUM CTB

Part VI. Separation Equipment

Operator will size the flowback separator to handle 11,000 Bbls of fluid and over 10MMscfd. Each separator is rated to 1440psig, and pressure control valves and

automated communication will cause the wells to shut in in the event of an upset at the facility, therefore no gas will be flared on pad during an upset. Current Oxy practices avoid use of flare or venting on pad, therefore if there is an upset or emergency condition at the facility, the wells will immediately shut down, and reassume production once the condition has cleared.

VII. Operational Practices

Gathering System and Pipeline Notification

Well(s) will be connected to a production facility after flowback operations are complete, where a gas transporter system is in place. The gas produced from production facility is dedicated to Enterprise Field Services, LLC ("Enterprise") and is connected to Enterprise low/high pressure gathering system located in Eddy County, New Mexico. OXY USA INC. ("OXY") provides (periodically) to Enterprise a drilling, completion and estimated first production date for wells that are scheduled to be drilled in the foreseeable future. In addition, OXY and Enterprise have periodic conference calls to discuss changes to drilling and completion schedules. Gas from these wells will be processed at Enterprise's Processing Plant located in Sec. 36, Twn. 24S, Rng. 30E, Eddy County, New Mexico. The actual flow of the gas will be based on compression operating parameters and gathering system pressures.

Flowback Strategy

After the fracture treatment/completion operations, well(s) will be produced to temporary production tanks and gas will be flared or vented. During flowback, the fluids and sand content will be monitored. When the produced fluids contain minimal sand, the wells will be turned to production facilities. Gas sales should start as soon as the wells start flowing through the production facilities, unless there are operational issues on Enterprise system at that time. Based on current information, it is OXY's belief the system can take this gas upon completion of the well(s).

Safety requirements during cleanout operations from the use of underbalanced air cleanout systems may necessitate that sand and non-pipeline quality gas be vented and/or flared rather than sold on a temporary basis.

VIII. Best Management Practices

Alternatives to Reduce Flaring

Below are alternatives considered from a conceptual standpoint to reduce the amount of gas flared.

Power Generation – On lease

Only a portion of gas is consumed operating the generator, remainder of gas will be flared

Compressed Natural Gas – On lease

Gas flared would be minimal, but might be uneconomical to operate when gas volume declines

NGL Removal – On lease

Plants are expensive, residue gas is still flared, and uneconomical to operate when gas volume declines

	SOUTH BONESPRING	
	Oil (bbl/d)	Gas (mcf/d)
Jan-2024	1,250	5,135
Feb-2024	1,184	6,041
Mar-2024	933	5,849
Apr-2024	670	5,349
May-2024	517	4,893
Jun-2024	421	4,401
Jul-2024	355	3,994
Aug-2024	306	3,652
Sep-2024	270	3,368
Oct-2024	240	3,125
Nov-2024	217	2,915
Dec-2024	197	2,731
Jan-2025	181	2,566
Feb-2025	167	2,426
Mar-2025	155	2,301
Apr-2025	145	2,184
May-2025	136	2,078
Jun-2025	127	1,982
Jul-2025	120	1,894
Aug-2025	114	1,812
Sep-2025	108	1,739
Oct-2025	102	1,670
Nov-2025	98	1,607
Dec-2025	93	1,549
Jan-2026	89	1,493
Feb-2026	85	1,444
Mar-2026	82	1,398
Apr-2026	79	1,353
May-2026	76	1,311
Jun-2026	73	1,271
Jul-2026	71	1,234
Aug-2026	68	1,198
Sep-2026	66	1,165
Oct-2026	64	1,133
Nov-2026	62	1,104
Dec-2026	60	1,075

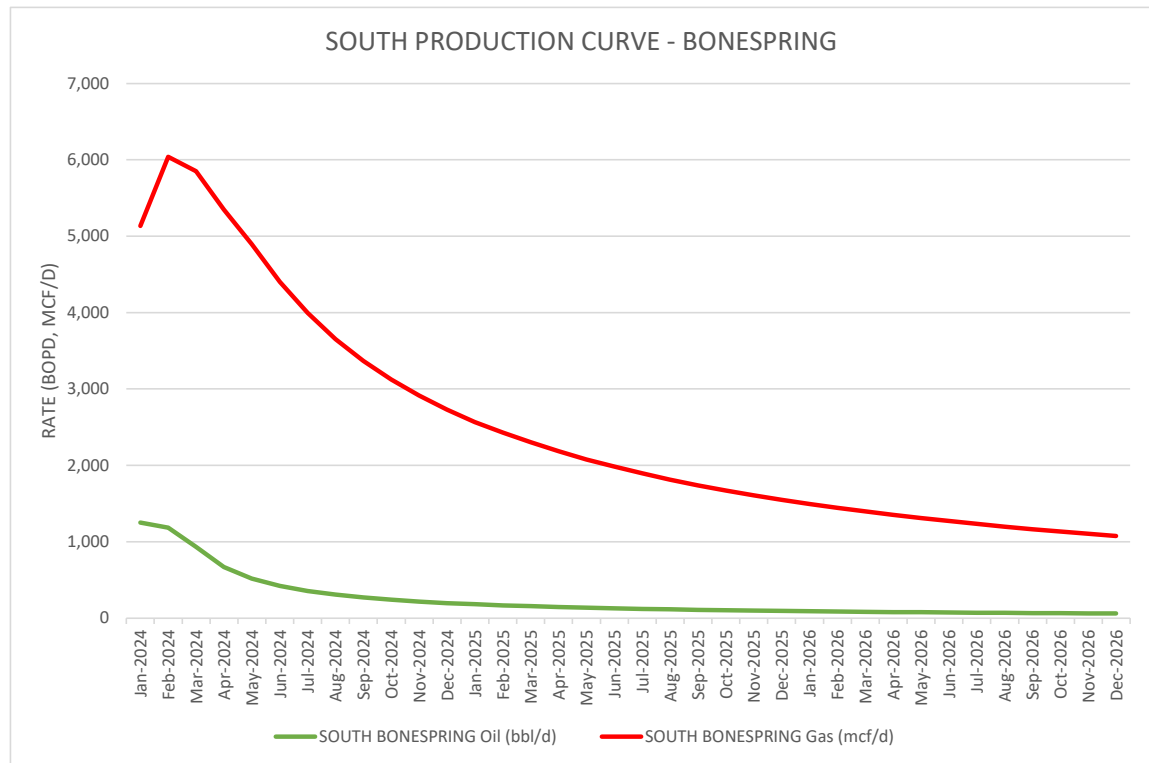

	SOUTH WOLFCAMP	
	Oil (bbl/d)	Gas (mcf/d)
Jan-2024	1,178	8,636
Feb-2024	995	8,951
Mar-2024	706	7,614
Apr-2024	544	6,588
May-2024	445	5,841
Jun-2024	377	5,261
Jul-2024	328	4,794
Aug-2024	291	4,402
Sep-2024	261	4,076
Oct-2024	238	3,797
Nov-2024	218	3,555
Dec-2024	201	3,343
Jan-2025	187	3,152
Feb-2025	175	2,990
Mar-2025	165	2,844
Apr-2025	156	2,708
May-2025	148	2,584
Jun-2025	140	2,471
Jul-2025	133	2,368
Aug-2025	127	2,272
Sep-2025	122	2,184
Oct-2025	117	2,104
Nov-2025	112	2,029
Dec-2025	108	1,959
Jan-2026	104	1,893
Feb-2026	101	1,834
Mar-2026	97	1,778
Apr-2026	94	1,725
May-2026	91	1,674
Jun-2026	89	1,626
Jul-2026	86	1,581
Aug-2026	84	1,538
Sep-2026	81	1,498
Oct-2026	79	1,460
Nov-2026	77	1,423
Dec-2026	75	1,389

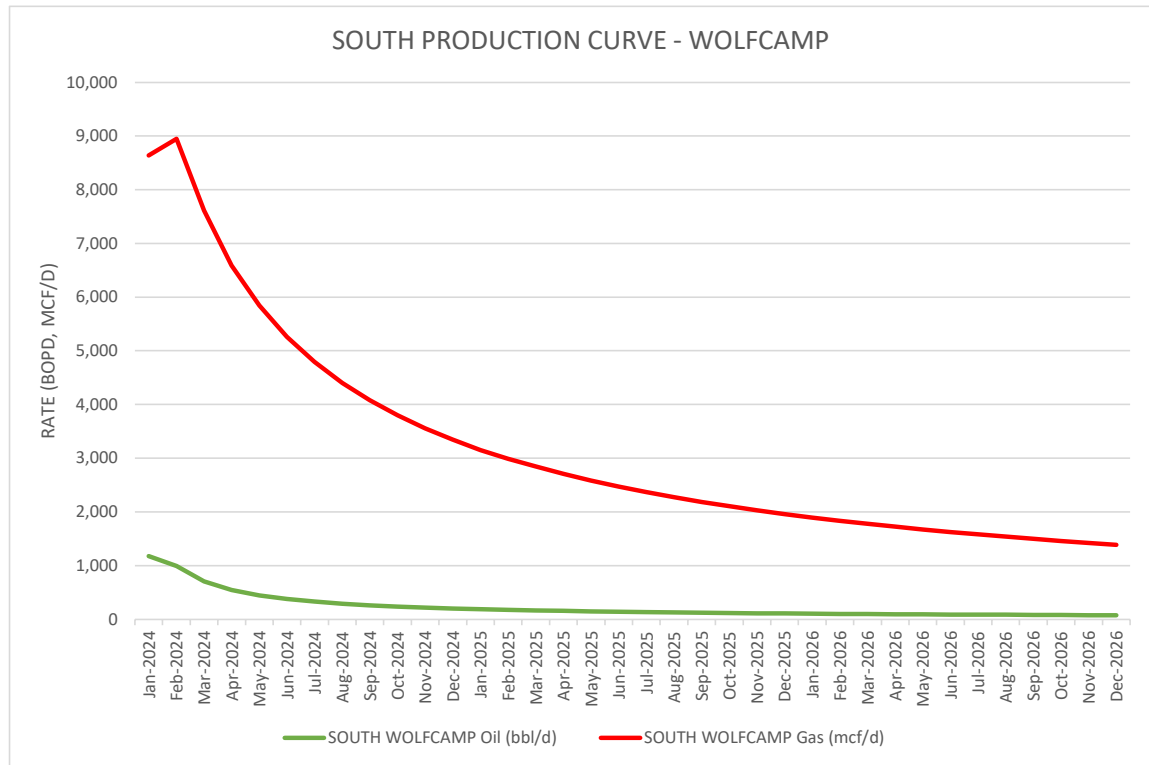

Oxy USA Inc. - PLATINUM MDP1 34_3 FED COM 52H Drill Plan

1. Geologic Formations

TVD of Target (ft):	12600	Pilot Hole Depth (ft):	
Total Measured Depth (ft):	22894	Deepest Expected Fresh Water (ft):	553

Delaware Basin

Formation	MD-RKB (ft)	TVD-RKB (ft)	Expected Fluids
Rustler	553	553	
Salado	883	883	Salt
Castile	2832	2832	Salt
Delaware	4306	4306	Oil/Gas/Brine
Bell Canyon	4334	4334	Oil/Gas/Brine
Cherry Canyon	5219	5219	Oil/Gas/Brine
Brushy Canyon	6481	6481	Losses
Bone Spring	8146	8146	Oil/Gas
Bone Spring 1st	9207	9207	Oil/Gas
Bone Spring 2nd	9805	9803	Oil/Gas
Bone Spring 3rd	11040	11021	Oil/Gas
Wolfcamp	11503	11477	Oil/Gas
Penn			Oil/Gas
Strawn			Oil/Gas

*H2S, water flows, loss of circulation, abnormal pressures, etc.

2. Casing Program

Section	Hole Size (in)	MD		TVD		Csg. OD (in)	Csg Wt. (ppf)	Grade	Conn.
		From (ft)	To (ft)	From (ft)	To (ft)				
Surface	17.5	0	613	0	613	13.375	54.5	J-55	BTC
Salt	12.25	0	4306	0	4306	10.75	45.5	L-80 HC	BTC-SC
Intermediate	9.875	0	12034	0	12000	7.625	26.4	L-80 HC	BTC
Production	6.75	0	22894	0	12600	5.5	20	P-110	Sprint-SF

All casing strings will be tested in accordance with 43 CFR part 3170 Subpart 3172

<i>All Casing SF Values will meet or exceed those below</i>			
SF Collapse	SF Burst	Body SF Tension	Joint SF Tension
1.00	1.100	1.4	1.4

	Y or N
Is casing new? If used, attach certification as required in 43 CFR 3160	Y
Does casing meet API specifications? If no, attach casing specification sheet.	Y
Is premium or uncommon casing planned? If yes attach casing specification sheet.	Y
Does the above casing design meet or exceed BLM's minimum standards? If not provide justification (loading assumptions, casing design criteria).	Y
Will the intermediate pipe be kept at a minimum 1/3 fluid filled to avoid approaching the collapse pressure rating of the casing?	Y
Is well located within Capitan Reef?	
If yes, does production casing cement tie back a minimum of 50' above the Reef?	N
Is well within the designated 4 string boundary.	
Is well located in SOPA but not in R-111-P?	
If yes, are the first 2 strings cemented to surface and 3 rd string cement tied back 500' into previous casing?	N
Is well located in R-111-P and SOPA?	
If yes, are the first three strings cemented to surface?	Y
Is 2 nd string set 100' to 600' below the base of salt?	Y
Is well located in high Cave/Karst?	
If yes, are there two strings cemented to surface?	N
(For 2 string wells) If yes, is there a contingency casing if lost circulation occurs?	
Is well located in critical Cave/Karst?	
If yes, are there three strings cemented to surface?	N

3. Cementing Program

Section	Stage	Slurry:	Sacks	Yield (ft ³ /ft)	Density (lb/gal)	Excess:	TOC	Placement	Description
Surface	1	Surface - Tail	640	1.33	14.8	100%	-	Circulate	Class C+Accel.
Int.1	1	Intermediate - Tail	85	1.33	14.8	20%	3,806	Circulate	Class C+Accel.
Int.1	1	Intermediate - Lead	605	1.73	12.9	50%	-	Circulate	Class Pozz+Ret.
Int. 2	1	Intermediate 1S - Tail	712	1.68	13.2	5%	6,731	Circulate	Class C+Ret., Disper.
Int. 2	2	Intermediate 2S - Tail BH	446	1.71	13.3	25%	3,806	Bradenhead Post-Frac	Class C+Accel.
Prod.	1	Production - Tail	643	1.84	13.3	25%	11,534	Circulate	Class C+Ret.

Offline Cementing Request

Oxy requests a variance to cement the 9.625" and/or 7.625" intermediate casing strings offline in accordance to the approved variance, EC Tran 461365. Please see Offline Cementing Variance attachment for further details.

Bradenhead CBL Request

Oxy requests permission to adjust the CBL requirement after bradenhead cement jobs, on 7-5/8" intermediate casings, as per the agreement reached in the OXY/BLM meeting on September 5, 2019. Please see Bradenhead CBL Variance attachment for further details.

4. Pressure Control Equipment

BOP installed and tested before drilling which hole?	Size?	Min. Required WP	Type	✓	Tested to:	TVD Depth (ft) per Section:
12.25" Hole	13-5/8"	5M	Annular	✓	70% of working pressure	4306
		5M	Blind Ram	✓	250 psi / 5000 psi	
			Pipe Ram			
			Double Ram	✓		
			Other*			
9.875" Hole	13-5/8"	5M	Annular	✓	70% of working pressure	12000
		5M	Blind Ram	✓	250 psi / 5000 psi	
			Pipe Ram			
			Double Ram	✓		
			Other*			
6.75" Hole	13-5/8"	5M	Annular	✓	100% of working pressure	12600
		10M	Blind Ram	✓	250 psi / 10000 psi	
			Pipe Ram			
			Double Ram	✓		
			Other*			

*Specify if additional ram is utilized

BOP/BOPE will be tested by an independent service company to 250 psi low and the high pressure indicated above per 43 CFR part 3170 Subpart 3172 requirements. The System may be upgraded to a higher pressure but still tested to the working pressure listed in the table above. If the system is upgraded all the components installed will be functional and tested.

Pipe rams will be operationally checked each 24 hour period. Blind rams will be operationally checked on each trip out of the hole. These checks will be noted on the daily tour sheets. Other accessories to the BOP equipment will include a Kelly cock and floor safety valve (inside BOP) and choke lines and choke manifold.

5M Annular BOP Request

Per BLM's Memorandum No. NM-2017-008: *Decision and Rationale for a Variance Allowing the Use of a 5M Annular Preventer with a 10M BOP Stack*, Oxy requests to employ a 5M annular with a 10M BOPE stack in the pilot and lateral sections of the well and will ensure that two barriers to flow are maintained at all times. Please see Annular BOP Variance attachment for further details.

	<p>Formation integrity test will be performed per 43 CFR part 3170 Subpart 3172.</p> <p>On Exploratory wells or on that portion of any well approved for a 5M BOPE system or greater, a pressure integrity test of each casing shoe shall be performed. Will be tested in accordance with 43 CFR part 3170 Subpart 3172.</p>
	<p>A variance is requested for the use of a flexible choke line from the BOP to Choke Manifold. See attached for specs and hydrostatic test chart.</p>
Y	<p>Are anchors required by manufacturer?</p>
	<p>A multibowl or a unionized multibowl wellhead system will be employed. The wellhead and connection to the BOPE will meet all API 6A requirements. The BOP will be tested per 43 CFR part 3170 Subpart 3172 after installation on the surface casing which will cover testing requirements for a maximum of 30 days. If any seal subject to test pressure is broken the system must be tested. We will test the flange connection of the wellhead with a test port that is directly in the flange. We are proposing that we will run the wellhead through the rotary prior to cementing surface casing as discussed with the BLM on October 8, 2015.</p> <p>See attached schematics.</p>

BOP Break Testing Request

Oxy requests permission to adjust the BOP break testing requirements as per the agreement reached in the OXY/BLM meeting on September 5, 2019. Please see BOP Break Testing Variance attachment for further details.

Oxy will use Cameron ADAPT wellhead system that uses an OEC top flange connection. This connection has been fully vetted and verified by API to Spec 6A and carries an API monogram.

5. Mud Program

Section	Depth		Depth - TVD		Type	Weight (ppg)	Viscosity	Water Loss
	From (ft)	To (ft)	From (ft)	To (ft)				
Surface	0	613	0	613	Water-Based Mud	8.6 - 8.8	40-60	N/C
Intermediate 1	613	4306	613	4306	Saturated Brine-Based or Oil-Based Mud	8.0 - 10.0	35-45	N/C
Intermediate 2	4306	12034	4306	12000	Water-Based or Oil-Based Mud	8.0 - 10.0	38-50	N/C
Production	12034	22894	12000	12600	Water-Based or Oil-Based Mud	9.5 - 13.5	38-50	N/C

Sufficient mud materials to maintain mud properties and meet minimum lost circulation and weight increase requirements will be kept on location at all times. The following is a general list of products: Barite, Bentonite, Gypsum, Lime, Soda Ash, Caustic Soda, Nut Plug, Cedar Fiber, Cotton Seed Hulls, Drilling Paper, Salt Water Clay, CACL2. Oxy will use a closed mud system.

What will be used to monitor the loss or gain of fluid?	PVT/MD Totco/Visual Monitoring
---	--------------------------------

6. Logging and Testing Procedures

Logging, Coring and Testing.	
Yes	Will run GR from TD to surface (horizontal well – vertical portion of hole). Stated logs run will be in the Completion Report and submitted to the BLM.
No	Logs are planned based on well control or offset log information.
No	Drill stem test? If yes, explain
No	Coring? If yes, explain
Additional logs planned	Interval
No	Resistivity
No	Density
Yes	CBL Production string
Yes	Mud log Bone Spring – TD
No	PEX

7. Drilling Conditions

Condition	Specify what type and where?
BH Pressure at deepest TVD	8846 psi
Abnormal Temperature	No
BH Temperature at deepest TVD	181°F

Pump high viscosity sweeps as needed for hole cleaning. The mud system will be monitored visually/manually as well as with an electronic PVT. The necessary mud products for additional weight and fluid loss control will be on location at all times. Appropriately weighted mud will be used to isolate potential gas, oil, and water zones until such time as casing can be cemented into place for zonal

Hydrogen Sulfide (H2S) monitors will be installed prior to drilling out the surface shoe. If H2S is detected in concentrations greater than 100 ppm, the operator will comply with the provisions of 43 CFR part 3170 Subpart 3172. If Hydrogen Sulfide is encountered, measured values and formations will be provided to the BLM.	
N	H2S is present
Y	H2S Plan attached

8. Other facets of operation

	Yes/No
Will the well be drilled with a walking/skidding operation? If yes, describe. We plan to drill the 2 well pad in batch by section: all surface sections, intermediate sections and production sections. The wellhead will be secured with a night cap whenever the rig is not over the well.	Yes
Will more than one drilling rig be used for drilling operations? If yes, describe. Oxy requests the option to contract a Surface Rig to drill, set surface casing, and cement for this well. If the timing between rigs is such that Oxy would not be able to preset surface, the Primary Rig will MIRU and drill the well in its entirety per the APD. Please see the attached document for information on the spudder rig.	Yes

Total Estimated Cuttings Volume: 1934 bbls

Offline Cementing Variance Request

Oxy requests a variance to cement the 9.625” and/or 7.625” intermediate casing strings offline in accordance to the approved variance, EC Tran 461365.

1. Cement Program

No changes to the cement program will take place for offline cementing.

2. Offline Cementing Procedure

The operational sequence will be as follows:

1. Run casing as per normal operations. While running casing, conduct negative pressure test and confirm integrity of the float equipment (float collar and shoe)
2. Land casing with mandrel
3. Fill pipe with kill weight fluid, do not circulate through floats and confirm well is static
4. Set annular packoff shown below and pressure test to confirm integrity of the seal.
Pressure ratings of wellhead components and valves is 5,000 psi

Annular packoff with both external and internal seals

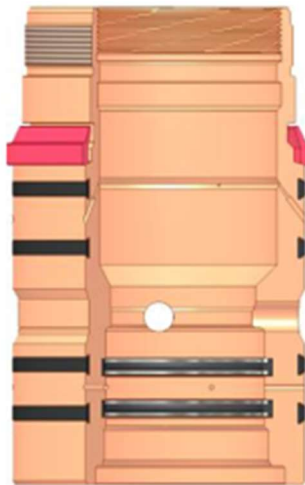

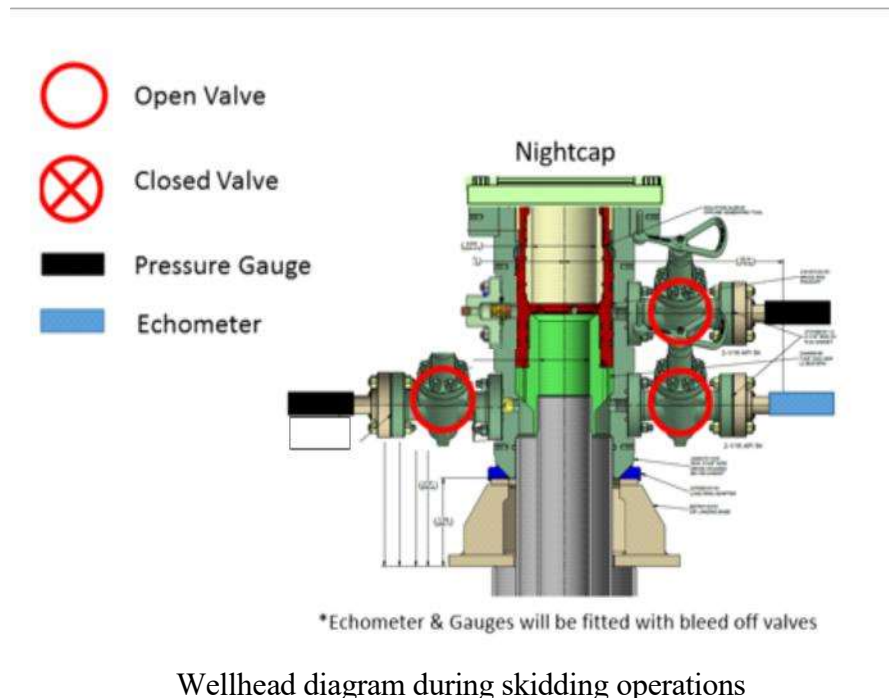

5. After confirmation of both annular barriers and internal barriers, nipple down BOP and install cap flange.
 - a. If any barrier fails to test, the BOP stack will not be nipped down until after the cement job is completed with cement 500ft above the highest formation capable of flow with kill weight mud above or after it has achieved 50 psi compressive strength if cannot be verified.
6. Skid rig to next well on pad.
7. Confirm well is static before removing cap flange, flange will not be removed and offline cementing operations will not commence until well is under control. If well is not static, casing outlet valves will provide access to both the casing ID and annulus. Rig or third party pump truck will kill well prior to cementing or nipping up for further remediation.
 - a. Well Control Plan
 - i. The Drillers Method will be the primary well control method to regain control of the wellbore prior to cementing, if wellbore conditions do not permit the drillers method other methods of well control may be used
 - ii. Rig pumps or a 3rd party pump will be tied into the upper casing valve to pump down the casing ID
 - iii. A high pressure return line will be rigged up to lower casing valve and run to choke manifold to control annular pressure
 - iv. Once influx is circulated out of the hole, kill weight mud will be circulated
 - v. Well will be confirmed static
 - vi. Once confirmed static, cap flange will be removed to allow for offline cementing operations to commence
8. Install offline cement tool
9. Rig up cement equipment

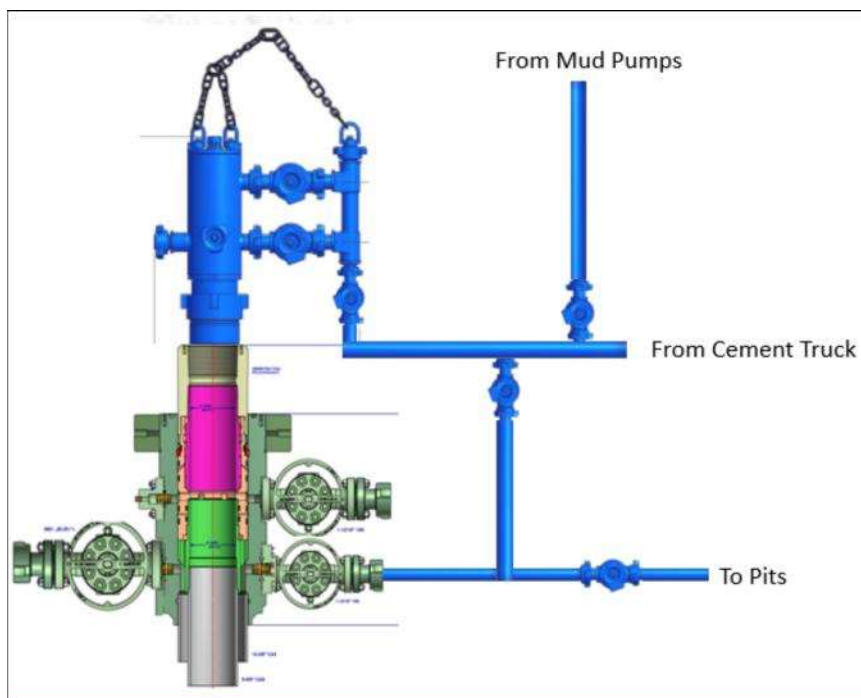

Wellhead diagram during offline cementing operations

10. Circulate bottoms up with cement truck
 - a. If gas is present on bottoms up, well will be shut in and returns rerouted through gas buster to handle entrained gas
 - b. Max anticipated time before circulating with cement truck is 6 hrs
11. Perform cement job taking returns from the annulus wellhead valve
12. Confirm well is static and floats are holding after cement job
13. Remove cement equipment, offline cement tools and install night cap with pressure gauge for monitoring.

BOP Break Testing Request

Oxy requests permission to adjust the BOP break testing requirements as per the agreement reached with OXY/BLM on April 4th, 2025.

BOPE Break Testing is ONLY permitted for 5M BOPE or less (utilizing a 10M BOPE system.)
Annular preventer must be tested to a minimum of 70% of BOPE working pressure and shall be higher than the MASP.

BOP break test for the **intermediate or production** section under the following conditions:

- After a full BOP test is conducted.
- When skidding to drill an intermediate or production section which does not penetrate the deeper than the Wolf Camp formation (<5M).
- In the event any repairs or replacement of the BOPE is required, the BOPE shall test as per 3 CFR part 3170 Subpart 3172
- While in transfer between wells, the BOPE shall be secured by the hydraulic carrier or cradle.
- In the event break testing is not utilized, then a full BOPE test would be conducted.
- If the kill line is broken prior to skid, two tests will be performed.
 - 1) Wellhead flange, co-flex hose, kill line connections and upper pipe rams
 - 2) Wellhead flange, HCR valve, check valve, upper pipe rams
- If the kill line is not broken prior to skid, only one test will be performed.
 - 1) Wellhead flange, co-flex hose, check valve, upper pipe rams

Subject: Request for a Variance Allowing Break Testing of a Blowout Preventer Stack

OXY USA Inc. (OXY) requests a variance to allow break testing of the Blowout Preventer (BOP) stack when skidding a drilling rig between wells on multi-well pads. This practice entails retesting only the connections of the **BOP** stack that have been disconnected during this operation and not a complete **BOP** test.

Background

43 CFR part 3170 Subpart 3172 states that a **BOP** test must be performed whenever any seal subject to test pressure is broken. The current interpretation of the Bureau of Land Management (BLM) is this requires a complete **BOP** test and not just a test of the affected component. 43 CFR part 3170 Subpart 3172, Section I.D.2. states, "Some situations may exist either on a well-by-well basis or field-wide basis whereby it is commonly accepted practice to vary a particular minimum standard(s) established in this Order. This situation can be resolved by requesting a variance...". OXY feels the practice of break testing the **BOP** stack is such a situation. Therefore, as per 43 CFR part 3170 Subpart 3172, Section IV., OXY submits this request for the variance.

Supporting Rationale

43 CFR part 3170 Subpart 3172 became effective on December 19, 1988, and has remained the standard for regulating BLM onshore drilling operations for almost 30 years. During this time there have been significant changes in drilling technology. **BLM** continues to use the variance request process to allow for the use of modern technology and acceptable engineering practices that have arisen since 43 CFR part 3170 Subpart 3172 was originally released. The drilling rig fleet OXY utilizes in New Mexico was built with many modern upgrades. One of which allows the rigs to skid between wells on multi-well pads. A part of this rig package is

a hydraulic winch system which safely installs and removes the BOP from the wellhead and carries it during skidding operations. This technology has made break testing a safe and reliable procedure.

American Petroleum Institute (API) standards, specifications and recommended practices are considered industry standards and are consistently utilized and referenced by the industry. 43 CFR part 3170 Subpart 3172 recognized API Recommended Practices (RP) 53 in its original development. API Standard 53, *Blowout Prevention Equipment Systems for Drilling Wells* (Fourth Edition, November 2012, Addendum 1, July 2016) recognizes break testing as an acceptable practice. Specifically, API Standard 53, Section 6.5.3.4.1.b states "Pressure tests on the well control equipment shall be conducted after the disconnection or repair of any pressure containment seal in the **BOP** stack, choke line, kill line, choke manifold, or wellhead assembly but limited to the affected component."

The Bureau of Safety and Environmental Enforcement (BSEE), Department of Interior, has also utilized the API standards, specifications and best practices in the development of its offshore oil and gas regulations and incorporates them by reference within its regulations. BSEE issued new offshore regulations under 30 CFR Part 250, *Oil and Gas and Sulphur Operations in the Outer Continental Shelf - Blowout Preventer Systems and Well Control*, which became effective on July 28, 2016. Section 250.737(d.1) states "Follow the testing requirements of API Standard 53". In addition, Section 250.737(d.8) has adopted language from **API** Standard 53 as it states "Pressure test affected **BOP** components following the disconnection or repair of any well-pressure containment seal in the wellhead or **BOP** stack assembly".

Break testing has been approved by the BLM in the past. See the Appendix for a Sundry Notice that was approved in 2015 by the Farmington Field Office. This approval granted permission for the operator to break test when skidding its Aztec 1000 rig on multi-well pads.

Oxy feels break testing and our current procedures meet the intent of 43 CFR part 3170 Subpart 3172 and often exceed it. We have not seen any evidence that break testing results in more components failing tests than seen on full BOP tests. As skidding operations take place within the 30-day full BOPE test window, the BOP shell and components such as the pipe rams and check valve get tested to the full rated working pressure more often. Therefore, there are more opportunities to ensure components are in good working order. Also, Oxy's standard requires complete BOP tests more often than that of 43 CFR part 3170 Subpart 3172. In addition to function testing the annular at least weekly and the pipe and blind rams on each trip, Oxy also performs a choke drill prior to drilling out every casing shoe. As a crew's training is a vital part of well control, this procedure to simulate step one of the Driller's Method exceeds the requirements of 43 CFR part 3170 Subpart 3172.

Procedures

- 1) OXY would perform BOP break testing on multi-well pads where multiple intermediate or production sections can be drilled and cased within the 21-day BOP test window
- 2) After performing a complete BOP test on the first well and drilling and casing the hole section, three breaks would be made on the BOP.
 - Between the check valve and the kill line
 - Between the HCR valve and the co-flex hose or the co-flex hose and the manifold
 - Between the BOP flange and the wellhead
- 3) The BOP is then lifted and removed from the wellhead by the hydraulic winch system
- 4) After skidding to the next well, the BOP is moved to the wellhead by the hydraulic winch system and installed
- 5) The choke line and kill line are reconnected
- 6) A test plug is installed in the wellhead with a joint of drill pipe and the internal parts of the check valve are removed
- 7) A shell test is performed against the upper pipe rams testing all three breaks
- 8) The internal parts of the check valve are reinstalled and the HCR valve is closed. A second test is performed on them
- 9) These tests consist of a 250 psi low test and a high test to the value submitted in the APD or SN (e.g., 5000 psi)
- 10) Perform a function test of components not pressure tested to include the lower pipe rams, the blind rams and the annular
- 11) If this were a three well pad, the same three breaks on the BOP would be made and steps 4 through 11 would be repeated
- 12) A second break test would only be done if the third hole section could be completed within the 21-day BOP test window
- 13) If a second break test is performed, additional components that were not tested on the initial break test will be tested on this break test

Notes:

- a. If any parts of the BOP are changed out or any additional breaks are made during the skidding operation, these affected components would also be tested as in step 10.
- b. As the choke manifold remains stationary during the skidding operation and the only break to the manifold is tested in step 8 above, no further testing of the manifold is done until the next full BOP test.

Summary

OXY requests a variance to allow break testing of the BOP stack when skidding drilling rigs between wells on multi-well pads. API standards, specifications and recommended practices are considered industry standards and are consistently utilized and referenced by the industry and the BLM. API Standard 53 recognizes break testing as an acceptable practice and BSEE adopted language from this standard into its newly created 30 CFR Part 250 which also supports break testing. Due to this, OXY feels this request meets the intent of 43 CFR part 3170

5M Annular BOP Variance Request

Per BLM's Memorandum No. NM-2017-008: *Decision and Rationale for a Variance Allowing the Use of a 5M Annular Preventer with a 10M BOP Stack*, Oxy requests to employ a 5M annular with a 10M BOPE stack in the pilot and lateral sections of the well and will ensure that two barriers to flow are maintained at all times. Please see Well Control Plan below.

Oxy Well Control Plan

A. Component and Preventer Compatibility Table

The table below, which covers the drilling and casing of the >5M MASP portion of the well, outlines the tubulars and the compatible preventers in use. This table, combined with the mud program, documents that two barriers to flow can be maintained at all times, independent of the rating of the annular preventer.

Pilot hole and Lateral sections, 10M requirement

Component	OD	Preventer	RWP
Drillpipe	4-1/2"-5"	Lower 3-1/2 - 5-1/2" VBR Upper 3-1/2 - 5-1/2" VBR	10M
HWDP	4-1/2"-5"	Lower 3-1/2 - 5-1/2" VBR Upper 3-1/2 - 5-1/2" VBR	10M
Drill collars and MWD tools	4-3/4" – 5-1/2"	Lower 3-1/2 - 5-1/2" VBR Upper 3-1/2 - 5-1/2" VBR	10M
Mud Motor	4-3/4"	Lower 3-1/2 - 5-1/2" VBR Upper 3-1/2 - 5-1/2" VBR	10M
Production casing	5-1/2"	Lower 3-1/2 - 5-1/2" VBR Upper 3-1/2 - 5-1/2" VBR	10M
ALL	0" - 13-5/8"	Annular	5M
Open-hole	6-3/4"	Blind Rams	10M

VBR = Variable Bore Ram. Compatible range listed in chart.

HWDP = Heavy Weight Drill Pipe

MWD = Measurement While Drilling

B. Well Control Procedures

Well control procedures are specific to the rig equipment and the operation at the time the kick occurs. Below are the minimal high-level tasks prescribed to assure a proper shut-in while drilling, tripping, running casing, pipe out of the hole (open hole), and moving the Bottom Hole Assembly (BHA) through the Blowout Preventers (BOP). The pressure at which control is swapped from the annular to another compatible ram will occur when the anticipated pressure is approaching or envisioned to exceed 70% of the 5M annular Rated Working Pressure (RWP) or 3500 PSI.

General Procedure While Drilling

1. Sound alarm (alert crew)
2. Space out drill string
3. Shut down pumps (stop pumps and rotary)
4. Shut-in Well (uppermost applicable BOP, typically annular preventer first. The Hydraulic Control Remote (HCR) valve and choke will already be in the closed position).
5. Confirm shut-in
6. Notify tool pusher/company representative
7. Read and record the following:
 - a. SIDPP and SICP
 - b. Pit gain
 - c. Time
8. Regroup and identify forward plan
9. If pressure has built or expected to reach 70% of the annular RWP during kill operations, crew will reconfirm spacing and swap to the upper pipe ram

General Procedure While Tripping

1. Sound alarm (alert crew)
2. Stab full opening safety valve and close
3. Space out drill string
4. Shut-in (uppermost applicable BOP, typically annular preventer first. The HCR and choke will already be in the closed position)
5. Confirm shut-in
6. Notify tool pusher/company representative
7. Read and record the following
 - a. SIDPP and SICP
 - b. Pit gain
 - c. Time
 - d. Regroup and identify forward plan
 - e. If pressure has built or is anticipated during the kill to reach the RWP of the annular preventer, confirm spacing and swap to the upper pipe ram

General Procedure While Running Casing

1. Sound alarm (alert crew)
2. Stab crossover and full opening safety valve and close
3. Space out string
4. Shut-in (uppermost applicable BOP, typically annular preventer first. The HCR and choke will already be in the closed position).
5. Confirm shut-in
6. Notify tool pusher/company representative
7. Read and record the following:
 - a. SIDPP and SICP
 - b. Pit gain
 - c. Time
 - d. Regroup and identify forward plan.
 - e. If pressure has built or is anticipated during the kill to reach the RWP of the annular preventer, confirm spacing and swap to compatible pipe ram.

General Procedure With No Pipe In Hole (Open Hole)

1. Sound alarm (alert crew)
2. Shut-in with blind rams or BSR. (The HCR and choke will already be in the closed position)
3. Confirm shut-in
4. Notify tool pusher/company representative
5. Read and record the following:
 - a. SICP
 - b. Pit gain
 - c. Time
6. Regroup and identify forward plan

General Procedures While Pulling BHA thru Stack

1. PRIOR to pulling last joint of drill pipe thru the stack.
 - a. Perform flow check, if flowing:
 - b. Sound alarm (alert crew)
 - c. Stab full opening safety valve and close
 - d. Space out drill string with tool joint just beneath the upper pipe ram
 - e. Shut-in using upper pipe ram. (The HCR and choke will already be in the closed position)
 - f. Confirm shut-in
 - g. Notify tool pusher/company representative
 - h. Read and record the following:
 - i. SIDPP and SICP
 - ii. Pit gain
 - iii. Time
 - iv. Regroup and identify forward plan
2. With BHA in the stack and compatible ram preventer and pipe combo immediately available.
 - a. Sound alarm (alert crew)
 - b. Stab crossover and full opening safety valve and close
 - c. Space out drill string with upset just beneath the compatible pipe ram
 - d. Shut-in using compatible pipe ram. (The HCR and choke will already be in the closed position.)
 - e. Confirm shut-in
 - f. Notify tool pusher/company representative
 - g. Read and record the following:
 - i. SIDPP and SICP
 - ii. Pit gain
 - iii. Time
 - iv. Regroup and identify forward plan
3. With BHA in the stack and NO compatible ram preventer and pipe combo immediately available.

- a. Sound alarm (alert crew)
- b. If possible to pick up high enough, pull string clear of the stack and follow “Open Hole” scenario
- c. If impossible to pick up high enough to pull the string clear of the stack
- d. Stab crossover, make up one joint/stand of drill pipe, and full opening safety valve and close
- e. Space out drill string with tool joint just beneath the upper pipe ram
- f. Shut-in using upper pipe ram. (The HCR and choke will already be in the closed position)
- g. Confirm shut-in
- h. Notify tool pusher/company representative
- i. Read and record the following:
 - i. SIDPP and SICP
 - ii. Pit gain
 - iii. Time
- j. Regroup and identify forward plan

Bradenhead Cement CBL Variance Request

Oxy requests permission to adjust the CBL requirement after bradenhead cement jobs, on 7-5/8” intermediate casings, as per the agreement reached in the OXY/BLM meeting on September 5, 2019.

Three string wells:

- CBL will be required on one well per pad
- If the pumped volume of cement is less than permitted in the APD, BLM will be notified and a CBL may be run
- Echometer will be used after bradenhead cement job to determine TOC before pumping top-out cement

Four string wells:

- CBL is not required
- If the pumped volume of cement is less than permitted in the APD, BLM will be notified and a CBL may be run
- Echometer will be used after bradenhead cement job to determine TOC before pumping top-out cement

Gas Separator Routing Flex III Rigs

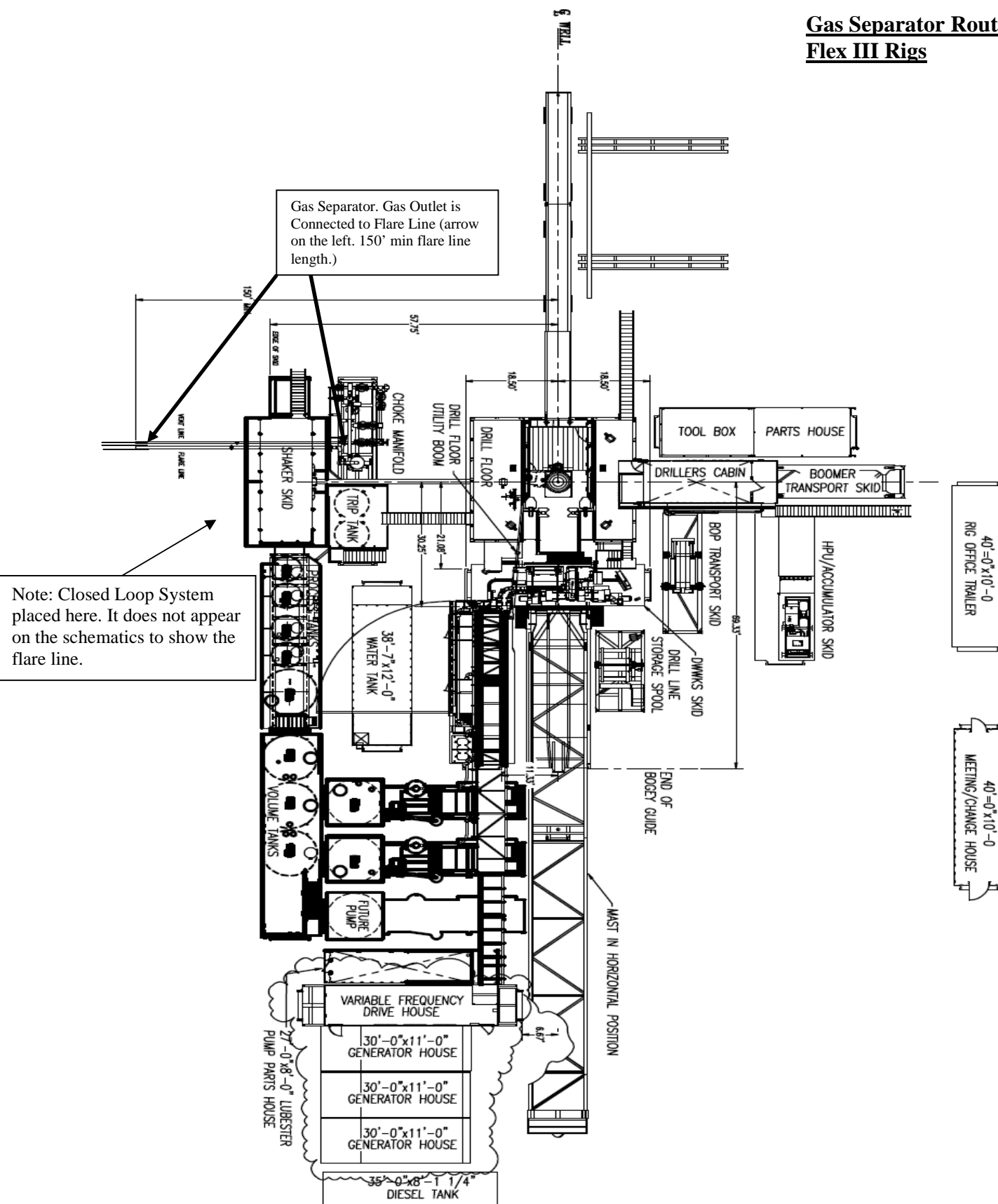

Choke Manifold – Gas Separator (Top View)

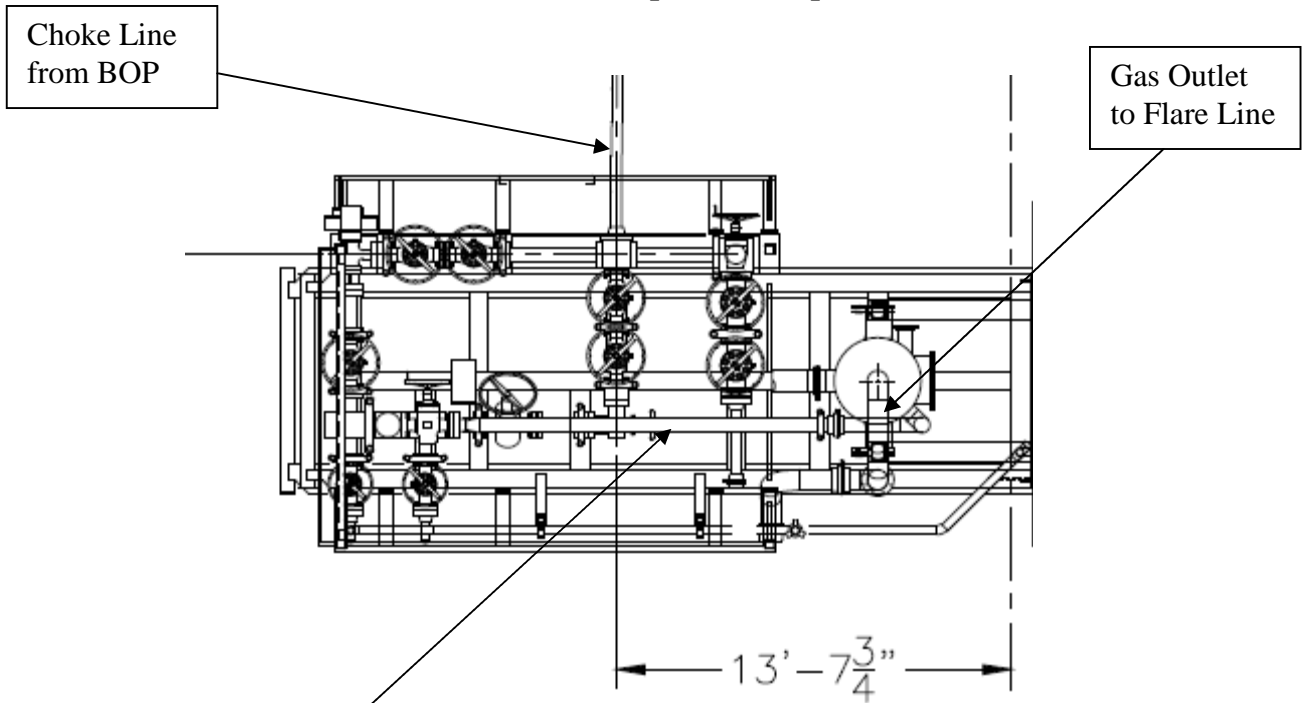

Choke Manifold – Gas Separator (Side View)

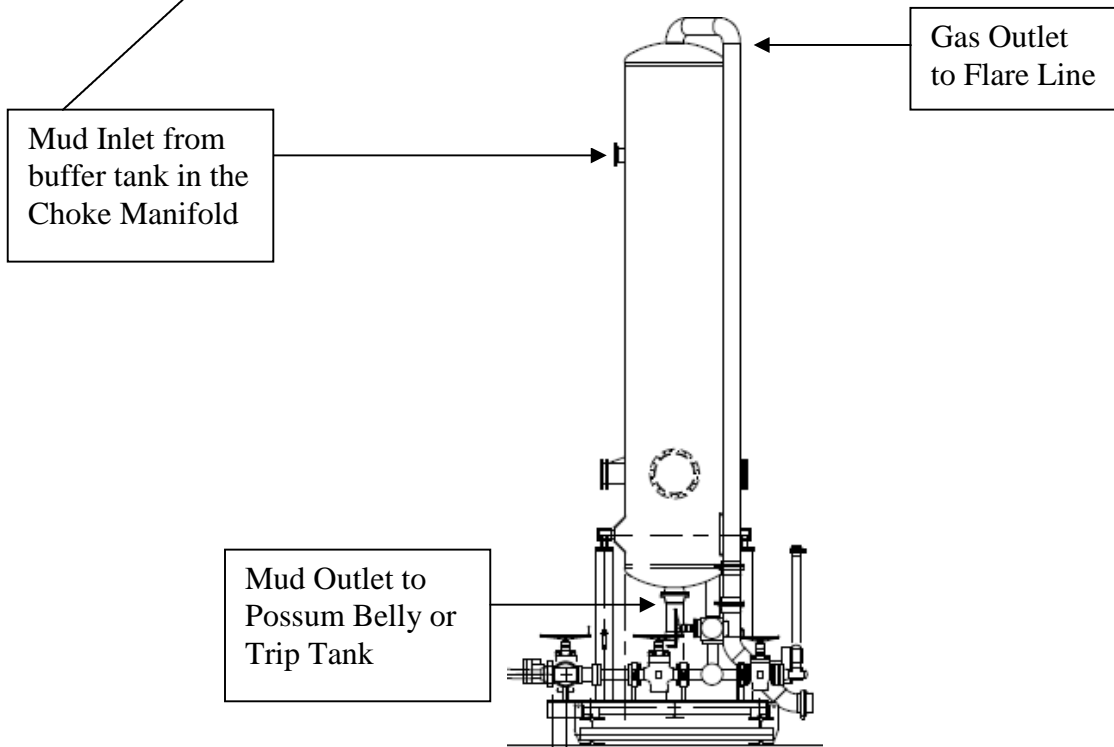

Sante Fe Main Office
Phone: (505) 476-3441

General Information
Phone: (505) 629-6116

Online Phone Directory
<https://www.emnrd.nm.gov/oecd/contact-us>

State of New Mexico
Energy, Minerals and Natural Resources
Oil Conservation Division
1220 S. St Francis Dr.
Santa Fe, NM 87505

ACKNOWLEDGMENTS

Action 546583

ACKNOWLEDGMENTS

Operator: OXY USA INC P.O. Box 4294 Houston, TX 772104294	OGRID: 16696
	Action Number: 546583
	Action Type: [C-101] BLM - Federal/Indian Land Lease (Form 3160-3)

ACKNOWLEDGMENTS

<input checked="" type="checkbox"/>	I hereby certify that no additives containing PFAS chemicals will be added to the completion or recompletion of this well.
-------------------------------------	--

Sante Fe Main Office
Phone: (505) 476-3441

General Information
Phone: (505) 629-6116

Online Phone Directory
<https://www.emnrd.nm.gov/ocd/contact-us>

**State of New Mexico
Energy, Minerals and Natural Resources
Oil Conservation Division
1220 S. St Francis Dr.
Santa Fe, NM 87505**

CONDITIONS

Action 546583

CONDITIONS

Operator: OXY USA INC P.O. Box 4294 Houston, TX 772104294	OGRID: 16696
	Action Number: 546583
	Action Type: [C-101] BLM - Federal/Indian Land Lease (Form 3160-3)

CONDITIONS

Created By	Condition	Condition Date
ronimathew	Cement is required to circulate on both surface and intermediate1 strings of casing.	1/27/2026
jeffrey.harrison	If the method of isolation was not by circulation, a CBL must be performed; if strata isolation is not achieved, then remediation will be required before further operations.	4/10/2026
jeffrey.harrison	This well is within the R-111-Q defined boundary. Operator must follow all procedures and requirements listed within the order.	4/10/2026
jeffrey.harrison	Administrative order required for non-standard location prior to production.	4/10/2026
jeffrey.harrison	All logs run on the well must be submitted to NMOCD.	4/10/2026
jeffrey.harrison	File As Drilled C-102 and a directional Survey with C-104 completion packet.	4/10/2026
jeffrey.harrison	Notify the OCD 24 hours prior to casing & cement.	4/10/2026
jeffrey.harrison	Once the well is spud, to prevent ground water contamination through whole or partial conduits from the surface, the operator shall drill without interruption through the fresh water zone or zones and shall immediately set in cement the water protection string.	4/10/2026
jeffrey.harrison	Oil base muds are not to be used until fresh water zones are cased and cemented providing isolation from the oil or diesel. This includes synthetic oils. Oil based mud, drilling fluids and solids must be contained in a steel closed loop system.	4/10/2026