

U.S. Department of the Interior  
BUREAU OF LAND MANAGEMENT

<b>Well Name:</b> MUY WAYNO 18 FEDERAL	<b>Well Location:</b> T25S / R30E / SEC 18 / LOT 3 / 32.129175 / -103.925511	<b>County or Parish/State:</b> EDDY / NM
<b>Well Number:</b> 703H	<b>Type of Well:</b> OIL WELL	<b>Allottee or Tribe Name:</b>
<b>Lease Number:</b> NMLC065705B, NMNM120898	<b>Unit or CA Name:</b> MUY WAYNO 80 102H 103H 104H 12	<b>Unit or CA Number:</b> NMNM140266
<b>US Well Number:</b> 3001544845	<b>Operator:</b> XTO ENERGY INCORPORATED	

**Notice of Intent**

**Sundry ID:** 2897584

**Type of Submission:** Notice of Intent

**Type of Action:** APD Change

**Date Sundry Submitted:** 02/24/2026

**Time Sundry Submitted:** 05:46

**Date proposed operation will begin:** 02/27/2026

**Procedure Description:** \*\*\*Well record Clean-up\*\*\* XTO ENERGY INCORPORATED respectfully requests approval to change the name of this well from "MUY WAYNO 18 FEDERAL 703H" to "MUY WAYNO 18-7 FEDERAL COM 163H" The API number for this well is 30-015-44845. Sundry Description submitted on 07/15/2021 - \*\* SHL Change, Casing/Cement, Drilling Variance Changes XTO Permian Operating, LLC requests permission to make the following changes to the original APD: No Additional Surface Disturbance SHL Change fr/2310'FSL & 1205'FWL to 2310'FSL & 1990'FWL. No change to take points or bottom hole locations. Casing/Cement design per the attached drilling program. XTO also requests the following variances: Approval to utilize a spudder rig to pre-set surface casing per the attached description of operations. Batch drill this well if necessary. In doing so, XTO will set each casing string and ensure that the well is cemented properly and the well is static. With floats holding, no pressure on the csg annulus, and the installation of a10K TA cap as per recommendations, XTO will contact the BLM to skid the rig to drill the remaining wells on the pad. Once surface and intermediate strings are all completed, XTO will begin drilling the production hole on each of the wells. ONLY test broken pressure seals on the BOP equipment per the attached procedure. A variance is requested to cement offline for the surface and intermediate casing strings. Attachments: Drilling Program Multi-bowl Diagram 5MBOP/5MCM Spudder Rig Description of Operations BOP Break Test Procedure Offline Cementing Procedure

**NOI Attachments**

**Procedure Description**

Muy\_Wayno\_18\_Federal\_703H\_Attachments\_20260310153450.pdf

MUY\_WAYNO\_18\_7\_FEDERAL\_COM\_163H\_96473\_C\_102\_FINAL\_02\_19\_2026\_20260224163403.pdf

Well Name: MUY WAYNO 18  
FEDERAL

Well Location: T25S / R30E / SEC 18 /  
LOT 3 / 32.129175 / -103.925511

County or Parish/State: EDDY 7  
NM

Well Number: 703H

Type of Well: OIL WELL

Allottee or Tribe Name:

Lease Number: NMLC065705B,  
NMNM120898

Unit or CA Name: MUY WAYNO 80  
102H 103H 104H 12

Unit or CA Number:  
NMNM140266

US Well Number: 3001544845

Operator: XTO ENERGY  
INCORPORATED

### Operator

I certify that the foregoing is true and correct. Title 18 U.S.C. Section 1001 and Title 43 U.S.C. Section 1212, make it a crime for any person knowingly and willfully to make to any department or agency of the United States any false, fictitious or fraudulent statements or representations as to any matter within its jurisdiction. Electronic submission of Sundry Notices through this system satisfies regulations requiring a

Operator Electronic Signature: VISHAL RAJAN

Signed on: MAR 10, 2026 03:44 PM

Name: XTO ENERGY INCORPORATED

Title: Regulatory Clerk

Street Address: 6401 HOLIDAY HILL ROAD BLDG 5

City: MIDLAND

State: TX

Phone: (432) 620-6704

Email address: VISHAL.RAJAN@EXXONMOBIL.COM

### Field

Representative Name:

Street Address:

City:

State:

Zip:

Phone:

Email address:

### BLM Point of Contact

BLM POC Name: TANJA BACA

BLM POC Phone: 5752345940

Disposition: Approved

Signature: Cody R. Layton

BLM POC Title: Supervisory Land Law Examiner

BLM POC Email Address: TABACA@BLM.GOV

Disposition Date: 04/03/2026

Form 3160-5  
(October 2024)

UNITED STATES  
DEPARTMENT OF THE INTERIOR  
BUREAU OF LAND MANAGEMENT

FORM APPROVED  
OMB No. 1004-0220  
Expires: October 31, 2027

**SUNDRY NOTICES AND REPORTS ON WELLS**  
**Do not use this form for proposals to drill or to re-enter an abandoned well. Use Form 3160-3 (APD) for such proposals.**

5. Lease Serial No.	NMLC065705B
6. If Indian, Allottee or Tribe Name	

<b>SUBMIT IN TRIPLICATE - Other instructions on page 2</b>		7. If Unit of CA/Agreement, Name and/or No. MUY WAYNO 80 102H 103H 104H 12/NMNM140266
1. Type of Well <input checked="" type="checkbox"/> Oil Well <input type="checkbox"/> Gas Well <input type="checkbox"/> Other		8. Well Name and No. MUY WAYNO 18 FEDERAL/703H
2. Name of Operator XTO ENERGY INCORPORATED		9. API Well No. 3001544845
3a. Address 15948 US HWY 77, ARDMORE, OK 73401	3b. Phone No. (include area code) (325) 338-8339	10. Field and Pool or Exploratory Area TRISTE DRAW/WOLFCAMP
4. Location of Well (Footage, Sec., T.,R.,M., or Survey Description) SEC 18/T25S/R30E/NMP		11. Country or Parish, State EDDY/NM

12. CHECK THE APPROPRIATE BOX(ES) TO INDICATE NATURE OF NOTICE, REPORT OR OTHER DATA

TYPE OF SUBMISSION	TYPE OF ACTION			
<input checked="" type="checkbox"/> Notice of Intent	<input type="checkbox"/> Acidize	<input type="checkbox"/> Deepen	<input type="checkbox"/> Production (Start/Resume)	<input type="checkbox"/> Water Shut-Off
<input type="checkbox"/> Subsequent Report	<input type="checkbox"/> Alter Casing	<input type="checkbox"/> Hydraulic Fracturing	<input type="checkbox"/> Reclamation	<input type="checkbox"/> Well Integrity
<input type="checkbox"/> Final Abandonment Notice	<input type="checkbox"/> Casing Repair	<input type="checkbox"/> New Construction	<input type="checkbox"/> Recomplete	<input type="checkbox"/> Other
	<input checked="" type="checkbox"/> Change Plans	<input type="checkbox"/> Plug and Abandon	<input type="checkbox"/> Temporarily Abandon	
	<input type="checkbox"/> Convert to Injection	<input type="checkbox"/> Plug Back	<input type="checkbox"/> Water Disposal	

13. Describe Proposed or Completed Operation: Clearly state all pertinent details, including estimated starting date of any proposed work and approximate duration thereof. If the proposal is to deepen directionally or recomplate horizontally, give subsurface locations and measured and true vertical depths of all pertinent markers and zones. Attach the Bond under which the work will be performed or provide the Bond No. on file with BLM/BIA. Required subsequent reports must be filed within 30 days following completion of the involved operations. If the operation results in a multiple completion or recompletion in a new interval, a Form 3160-4 must be filed once testing has been completed. Final Abandonment Notices must be filed only after all requirements, including reclamation, have been completed and the operator has determined that the site is ready for final inspection.)

\*\*\*Well record Clean-up\*\*\*

XTO ENERGY INCORPORATED respectfully requests approval to change the name of this well from "MUY WAYNO 18 FEDERAL 703H" to "MUY WAYNO 18-7 FEDERAL COM 163H"  
The API number for this well is 30-015-44845.

Sundry Description submitted on 07/15/2021 -

\*\* SHL Change, Casing/Cement, Drilling Variance Changes XTO Permian Operating, LLC requests permission to make the following changes to the original APD: No Additional Surface Disturbance SHL Change fr/2310'FSL & 1205'FWL to 2310'FSL & 1990'FWL. No change to take points or bottom hole locations. Casing/Cement design per the attached drilling program. XTO also requests the following variances: Approval to utilize a spudder rig to pre-set surface casing per the attached description of operations. Batch drill this well if necessary. In doing so, XTO will set each casing string and ensure that the well is cemented properly and the well is static. With floats holding, no pressure on the csg annulus, and the installation of a10K TA cap as per recommendations, XTO will contact the BLM to skid the rig to drill the remaining wells on  
Continued on page 3 additional information

14. I hereby certify that the foregoing is true and correct. Name (Printed/Typed) VISHAL RAJAN / Ph: (432) 620-6704	Title Regulatory Clerk
Signature (Electronic Submission)	Date 03/10/2026

**THE SPACE FOR FEDERAL OR STATE OFFICE USE**

Approved by CODY LAYTON / Ph: (575) 234-5959 / Approved	Title Assistant Field Manager Lands & I	Date 04/03/2026
Conditions of approval, if any, are attached. Approval of this notice does not warrant or certify that the applicant holds legal or equitable title to those rights in the subject lease which would entitle the applicant to conduct operations thereon.	Office CARLSBAD	

Title 18 U.S.C Section 1001 and Title 43 U.S.C Section 1212, make it a crime for any person knowingly and willfully to make to any department or agency of the United States any false, fictitious or fraudulent statements or representations as to any matter within its jurisdiction.

(Instructions on page 2)

## GENERAL INSTRUCTIONS

This form is designed for submitting proposals to perform certain well operations and reports of such operations when completed as indicated on Federal and Indian lands pursuant to applicable Federal law and regulations. Any necessary special instructions concerning the use of this form and the number of copies to be submitted, particularly with regard to local area or regional procedures and practices, are either shown below, will be issued by or may be obtained from the local Federal office.

## SPECIFIC INSTRUCTIONS

*Item 4* - Locations on Federal or Indian land should be described in accordance with Federal requirements. Consult the local Federal office for specific instructions.

*Item 13*: Proposals to abandon a well and subsequent reports of abandonment should include such special information as is required by the local Federal office. In addition, such proposals and reports should include reasons for the abandonment; data on any former or present productive zones or other zones with present significant fluid contents not sealed off by cement or otherwise; depths (top and bottom) and method of placement of cement plugs; mud or other material placed below, between and above plugs; amount, size, method of parting of any casing, liner or tubing pulled and the depth to the top of any tubing left in the hole; method of closing top of well and date well site conditioned for final inspection looking for approval of the abandonment. If the proposal will involve **hydraulic fracturing operations**, you must comply with 43 CFR 3162.3-3, including providing information about the protection of usable water. Operators should provide the best available information about all formations containing water and their depths. This information could include data and interpretation of resistivity logs run on nearby wells. Information may also be obtained from state or tribal regulatory agencies and from local BLM offices.

## NOTICES

The privacy Act of 1974 and the regulation in 43 CFR 2.48(d) provide that you be furnished the following information in connection with information required by this application.

AUTHORITY: 30 U.S.C. 181 et seq., 351 et seq., 25 U.S.C. 396; 43 CFR 3160.

PRINCIPAL PURPOSE: The information is used to: (1) Evaluate, when appropriate, approve applications, and report completion of subsequent well operations, on a Federal or Indian lease; and (2) document for administrative use, information for the management, disposal and use of National Resource lands and resources, such as: (a) evaluating the equipment and procedures to be used during a proposed subsequent well operation and reviewing the completed well operations for compliance with the approved plan; (b) requesting and granting approval to perform those actions covered by 43 CFR 3162.3-2, 3162.3-3, and 3162.3-4; (c) reporting the beginning or resumption of production, as required by 43 CFR 3162.4-1(c) and (d) analyzing future applications to drill or modify operations in light of data obtained and methods used.

ROUTINE USES: Information from the record and/or the record will be transferred to appropriate Federal, State, local or foreign agencies, when relevant to civil, criminal or regulatory investigations or prosecutions in connection with congressional inquiries or to consumer reporting agencies to facilitate collection of debts owed the Government.

EFFECT OF NOT PROVIDING THE INFORMATION: Filing of this notice and report and disclosure of the information is mandatory for those subsequent well operations specified in 43 CFR 3162.3-2, 3162.3-3, 3162.3-4.

The Paperwork Reduction Act of 1995 requires us to inform you that:

The BLM collects this information to evaluate proposed and/or completed subsequent well operations on Federal or Indian oil and gas leases.

Response to this request is mandatory.

The BLM would like you to know that you do not have to respond to this or any other Federal agency-sponsored information collection unless it displays a currently valid OMB control number.

**BURDEN HOURS STATEMENT:** Public reporting burden for this form is estimated to average 8 hours per response, including the time for reviewing instructions, gathering and maintaining data, and completing and reviewing the form. Direct comments regarding the burden estimate or any other aspect of this form to U.S. Department of the Interior, Bureau of Land Management (1004-0137), Bureau Information Collection Clearance Officer (WO-630), 1849 C St., N.W., Mail Stop 401 LS, Washington, D.C. 20240

## Additional Information

### Additional Remarks

the pad. Once surface and intermediate strings are all completed, XTO will begin drilling the production hole on each of the wells. ONLY test broken pressure seals on the BOP equipment per the attached procedure. A variance is requested to cement offline for the surface and intermediate casing strings. Attachments: Drilling Program Multi-bowl Diagram 5MBOP/5MCM Spudder Rig Description of Operations BOP Break Test Procedure Offline Cementing Procedure

### Location of Well

0. SHL: LOT 3 / 2310 FSL / 1205 FWL / TWSP: 25S / RANGE: 30E / SECTION: 18 / LAT: 32.129175 / LONG: -103.925511 ( TVD: 0 feet, MD: 0 feet )

PPP: SENW / 2310 FNL / 1650 FWL / TWSP: 25S / RANGE: 30E / SECTION: 7 / LAT: 32.131096 / LONG: -103.924078 ( TVD: 9229 feet, MD: 9600 feet )

BHL: NENW / 200 FNL / 1650 FWL / TWSP: 25S / RANGE: 30E / SECTION: 7 / LAT: 32.151495 / LONG: -103.924106 ( TVD: 9229 feet, MD: 17096 feet )



DRILLING PLAN: BLM COMPLIANCE  
(Supplement to BLM 3160-3)

XTO Energy Inc.  
Muy Wayno 18 Federal 703H  
Projected TD: 19345' MD / 11560' TVD  
SHL: 2310' FSL & 1990' FWL , Section 18, T25S, R30E  
BHL: 200' FNL & 2310' FWL , Section 7, T25S, R30E  
Eddy County, NM

1. Geologic Name of Surface Formation

A. Quaternary

2. Estimated Tops of Geological Markers & Depths of Anticipated Fresh Water, Oil or Gas

Formation	Well Depth (TVD)	Water/Oil/Gas
Rustler	758'	Water
Top of Salt	1073'	Water
Base of Salt	3333'	Water
Delaware	3533'	Water
Brushy Canyon	6013'	Water/Oil/Gas
Bone Spring	7253'	Water
1st Bone Spring Ss	8238'	Water/Oil/Gas
2nd Bone Spring Ss	9078'	Water/Oil/Gas
3rd Bone Spring Ss	10158'	Water/Oil/Gas
Wolfcamp	10533'	Water/Oil/Gas
Wolfcamp X	10563'	Water/Oil/Gas
Wolfcamp Y	10628'	Water/Oil/Gas
Wolfcamp A	10673'	Water/Oil/Gas
Wolfcamp B	11063'	Water/Oil/Gas
Wolfcamp D	11463'	Water/Oil/Gas
Wolfcamp E	11623'	Water/Oil/Gas
Target/Land Curve	11560'	Water/Oil/Gas

\*\*\* Hydrocarbons @ Brushy Canyon  
\*\*\* Groundwater depth 40' (per NM State Engineers Office).

No other formations are expected to yield oil, gas or fresh water in measurable volumes. The surface fresh water sands will be protected by setting 9.625 inch casing @ 973' (100' above the salt) and circulating cement back to surface. The intermediate will isolate from the top of salt down to the next casing seat by setting 7.625 inch casing at 10796' and cemented to surface. A 6.75 inch curve and 6.75 inch lateral hole will be drilled to 19345 MD/TD and 5.5 x 5 inch production casing will be set at TD and cemented back up to 2nd intermediate (estimated TOC 10496 feet).

3. Casing Design

Hole Size	Depth	OD Csg	Weight	Grade	Collar	New/Used	SF Burst	SF Collapse	SF Tension
12.25	0' – 973'	9.625	40	J-55	BTC	New	1.29	5.84	16.19
8.75	0' – 4000'	7.625	29.7	RY P-110	Flush Joint	New	2.16	2.65	1.74
8.75	4000' – 10796'	7.625	29.7	HC L-80	Flush Joint	New	1.57	1.86	2.01
6.75	0' – 10696'	5.5	23	RY P-110	Semi-Premium	New	1.21	2.27	2.29
6.75	10696' - 11300'	5.5	23	RY P-110	Semi-Flush	New	1.21	2.15	8.43
6.75	11300' - 19345'	5	18	RY P-110	Semi-Premium	New	1.16	1.95	10.00

- XTO requests the option to utilize a spudder rig (Atlas Copco RD20 or Equivalent) to set and cement surface and intermediate 1 casing per this Sundry
- XTO requests to not utilize centralizers in the curve and lateral
- 7.625 Collapse analyzed using 50% evacuation based on regional experience.
- 5.5 Tension calculated using vertical hanging weight plus the lateral weight multiplied by a friction factor of 0.35
- Test on Casing will be limited to 70% burst of the casing or 1500 psi, whichever is less

- XTO requests the option to use 5" BTC Float equipment for the the production casing

**Wellhead:**

*Permanent Wellhead – Multibowl System*

A. Starting Head: 13-5/8" 10M top flange x 9-5/8" SOW bottom

B. Tubing Head: 13-5/8" 10M bottom flange x 7-1/16" 15M top flange

- Wellhead will be installed by manufacturer's representatives.
- Manufacturer will monitor welding process to ensure appropriate temperature of seal.
- Operator will test the 7-5/8" casing per BLM Onshore Order 2
- Wellhead Manufacturer representative will not be present for BOP test plug installation

#### 4. Cement Program

##### **Surface Casing: 9.625, 40 New BTC, J-55 casing to be set at +/- 973'**

Lead: 220 sxs EconoCem-HLTRRC (mixed at 12.9 ppg, 1.87 ft<sup>3</sup>/sx, 10.13 gal/sx water)  
 Tail: 130 sxs Class C + 2% CaCl (mixed at 14.8 ppg, 1.35 ft<sup>3</sup>/sx, 6.39 gal/sx water)  
 Top of Cement: Surface  
 Compressives: 12-hr = 900 psi 24 hr = 1500 psi

##### **2nd Intermediate Casing: 7.625, 29.7 New casing to be set at +/- 10796'**

###### 1st Stage

Optional Lead: 320 sxs Class C (mixed at 10.5 ppg, 2.77 ft<sup>3</sup>/sx, 15.59 gal/sx water)  
 TOC: Surface  
 Tail: 440 sxs Class C (mixed at 14.8 ppg, 1.35 ft<sup>3</sup>/sx, 6.39 gal/sx water)  
 TOC: Brushy Canyon @ 6013  
 Compressives: 12-hr = 900 psi 24 hr = 1150 psi

###### 2nd Stage

Lead: 0 sxs Class C (mixed at 12.9 ppg, 2.16 ft<sup>3</sup>/sx, 9.61 gal/sx water)  
 Tail: 680 sxs Class C (mixed at 14.8 ppg, 1.33 ft<sup>3</sup>/sx, 6.39 gal/sx water)  
 Top of Cement: 0  
 Compressives: 12-hr = 900 psi 24 hr = 1150 psi

XTO requests to pump a two stage cement job on the 7-5/8" intermediate casing string with the first stage being pumped conventionally with the calculated top of cement at the Brush Canyon (6013') and the second stage performed as a bradenhead squeeze with planned cement from the Brushy Canyon to surface. If cement is not visually confirmed to circulate to surface, the final cement top after the second stage job will be verified by Echo-meter. If necessary, a top out consisting of 1,500 sack of Class C cement + 3% Salt + 1% PreMag-M + 6% Bentonite Gel (2.30 yld, 12.91 ppg) will be executed as a contingency. If cement is still unable to circulate to surface, another Echo-meter run will be performed for cement top verification.

XTO will include the Echo-meter verified fluid top and the volume of displacement fluid above the cement slurry in the annulus in all post-drill sundries on wells utilizing this cement program.

XTO will report to the BLM the volume of fluid (limited to 5 bbls) used to flush intermediate casing valves following backside cementing procedures.

XTO requests to pump an Optional Lead if well conditions dictate in an attempt to bring cement inside the first intermediate casing. If cement reaches the desired height, the BLM will be notified and the second stage bradenhead squeeze and subsequent TOC verification will be negated.

XTO requests the option to conduct the bradenhead squeeze and TOC verification offline as per standard approval from BLM when unplanned remediation is needed and batch drilling is approved. In the event the bradenhead is conducted, we will ensure the first stage cement job is cemented properly and the well is static with floats holding and no pressure on the csg annulus as with all other casing strings where batch drilling operations occur before moving off the rig. The TA cap will also be installed per Cactus procedure and pressure inside the casing will be monitored via the valve on the TA cap as per standard batch drilling ops.

##### **Production Casing: 5, 18 New Semi-Premium, RY P-110 casing to be set at +/- 19345'**

Lead: 20 sxs NeoCem (mixed at 11.5 ppg, 2.69 ft<sup>3</sup>/sx, 15.00 gal/sx water) Top of Cement: 10496 feet  
 Tail: 790 sxs VersaCem (mixed at 13.2 ppg, 1.51 ft<sup>3</sup>/sx, 8.38 gal/sx water) Top of Cement: 10996 feet  
 Compressives: 12-hr = 800 psi 24 hr = 1500 psi

XTO requests the option to offline cement and remediate (if needed) surface and intermediate casing strings where batch drilling is approved and if unplanned remediation is needed. XTO will ensure well is static with no pressure on the csg annulus, as with all other casing strings where batch drilling operations occur before moving off the rig. The TA cap will also be installed when applicable per Cactus procedure and pressure inside the casing will be monitored via the valve on the TA cap as per standard batch drilling ops. Offline cement operations will then be conducted after the rig is moved off the current well to the next well in the batch sequence.

## 5. Pressure Control Equipment

Once the permanent WH is installed on the 9.625 casing, the blow out preventer equipment (BOP) will consist of a 13-5/8" minimum 5M Hydril and a 13-5/8" minimum 5M Double Ram BOP. MASP should not exceed 4370 psi. In any instance where 10M BOP is required by BLM, XTO requests a variance to utilize 5M annular with 10M ram preventers (a common BOP configuration, which allows use of 10M rams in unlikely event that pressures exceed 5M).

All BOP testing will be done by an independent service company. Annular pressure tests will be limited to 50% of the working pressure. When nipping up on the 9.625, 5M bradenhead and flange, the BOP test will be limited to 5000 psi. When nipping up on the 7.625, the BOP will be tested to a minimum of 5000 psi. All BOP tests will include a low pressure test as per BLM regulations. The 5M BOP diagrams are attached. Blind rams will be functioned tested each trip, pipe rams will be functioned tested each day.

A variance is requested to allow use of a flex hose as the choke line from the BOP to the Choke Manifold. If this hose is used, a copy of the manufacturer's certification and pressure test chart will be kept on the rig. Attached is an example of a certification and pressure test chart. The manufacturer does not require anchors.

XTO requests a variance to be able to batch drill this well if necessary. In doing so, XTO will set casing and ensure that the well is cemented properly (unless approval is given for offline cementing) and the well is static. With floats holding, no pressure on the csg annulus, and the installation of a 10K TA cap as per Cactus recommendations, XTO will contact the BLM to skid the rig to drill the remaining wells on the pad. Once surface and both intermediate strings are all completed, XTO will begin drilling the production

hole on each of the wells.

A variance is requested to **ONLY** test broken pressure seals on the BOP equipment when moving from wellhead to wellhead which is in compliance with API Standard 53. API standard 53 states, that for pad drilling operation, moving from one wellhead to another within 21 days, pressure testing is required for pressure-containing and pressure-controlling connections when the integrity of a pressure seal is broken. Based on discussions with the BLM on February 27th 2020, we will request permission to **ONLY** retest broken pressure seals if the following conditions are met: 1. After a full BOP test is conducted on the first well on the pad 2. When skidding to drill an intermediate section that does not penetrate into the Wolfcamp.

## 6. Proposed Mud Circulation System

INTERVAL	Hole Size	Mud Type	MW (ppg)	Viscosity (sec/qt)	Fluid Loss (cc)
0' - 973'	12.25	FW/Native	8.7-9.2	35-40	NC
973' - 10796'	8.75	FW / Cut Brine / Direct Emulsion	9.7-10.2	30-32	NC
10796' - 19345'	6.75	OBM	11.5-12	50-60	NC - 20

The necessary mud products for weight addition and fluid loss control will be on location at all times.

Spud with fresh water/native mud. Drill out from under 9-5/8" surface casing with brine solution. A 9.7 ppg - 10.2 ppg cut brine mud will be used while drilling through the salt formation. Use fibrous materials as needed to control seepage and lost circulation. Pump viscous sweeps as needed for hole cleaning. Pump speed will be recorded on a daily drilling report after mudding up. A Pason or Totco will be used to detect changes in loss or gain of mud volume. A mud test will be performed every 24 hours to determine: density, viscosity, strength, filtration and pH as necessary. Use available solids controls equipment to help keep mud weight down after mud up. Rig up solids control equipment to operate as a closed loop system.

## 7. Auxiliary Well Control and Monitoring Equipment

- A. A Kelly cock will be in the drill string at all times.
- B. A full opening drill pipe stabbing valve having appropriate connections will be on the rig floor at all times.
- C. H2S monitors will be on location when drilling below the 9.625 casing.

## 8. Logging, Coring and Testing Program

Mud Logger: Mud Logging Unit (2 man) below intermediate casing.

Open hole logging will not be done on this well.

## 9. Abnormal Pressures and Temperatures / Potential Hazards

None Anticipated. BHT of 180 to 200 F is anticipated. No H2S is expected but monitors will be in place to detect any H2S occurrences. Should these circumstances be encountered the operator and drilling contractor are prepared to take all necessary steps to ensure safety of all personnel and environment. Lost circulation could occur but is not expected to be a serious problem in this area and hole seepage will be compensated for by additions of small amounts of LCM in the drilling fluid. The maximum anticipated bottom hole pressure for this well is 6913 psi.

## 10. Anticipated Starting Date and Duration of Operations

Anticipated spud date will be after BLM approval. Move in operations and drilling is expected to take 40 days.

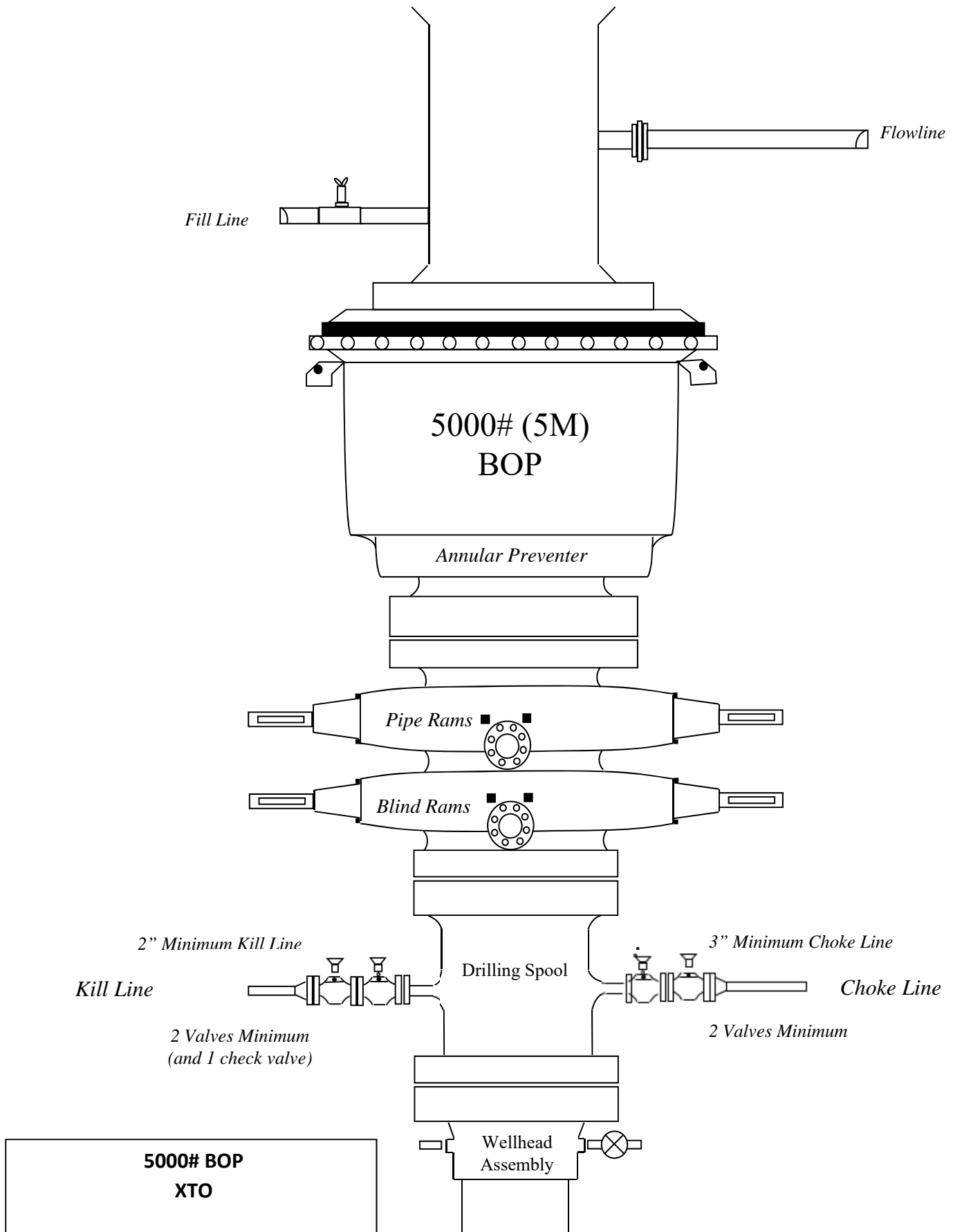

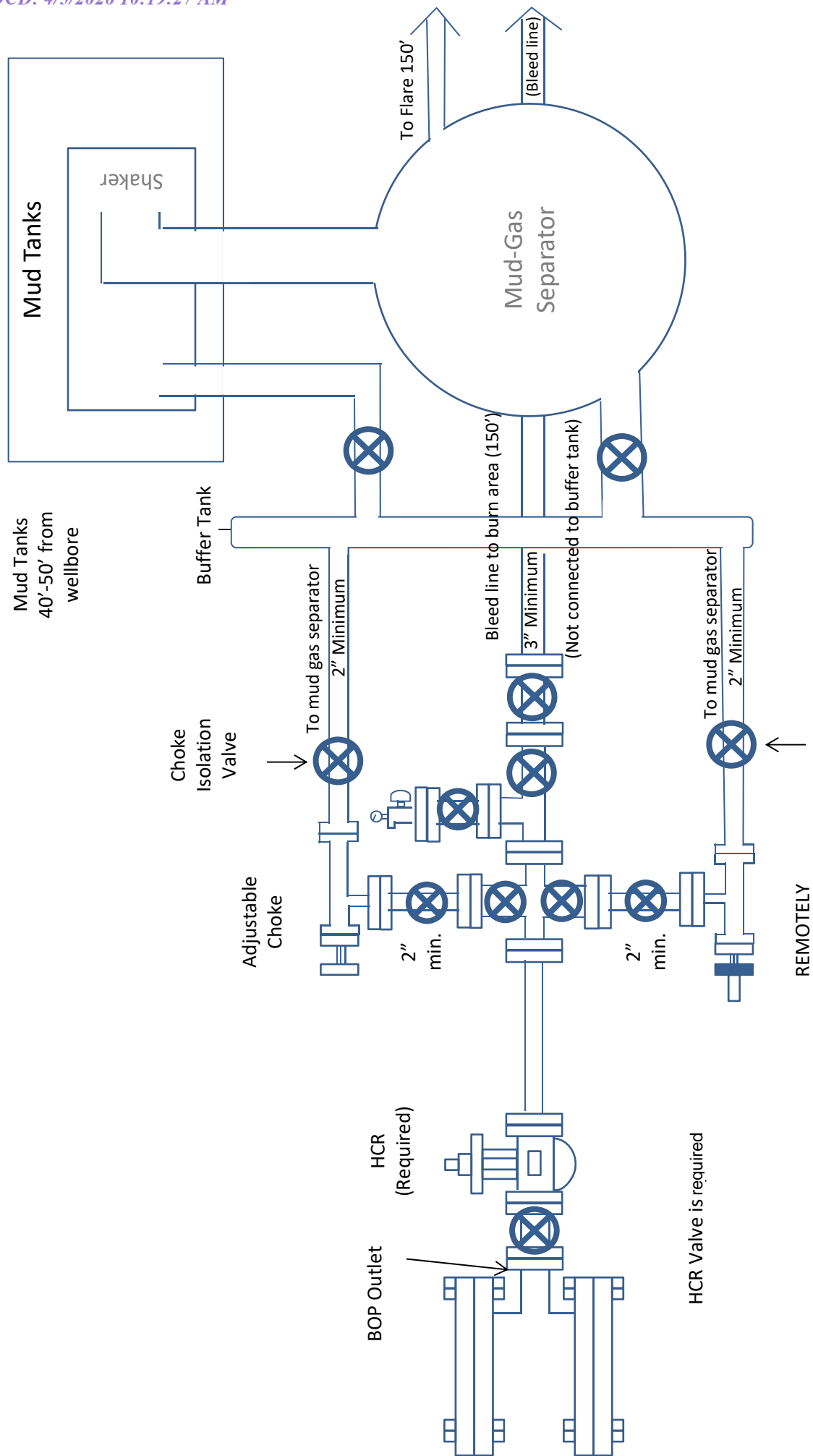

5M Choke Manifold Diagram XTO

### Drilling Operations Choke Manifold 5M Service

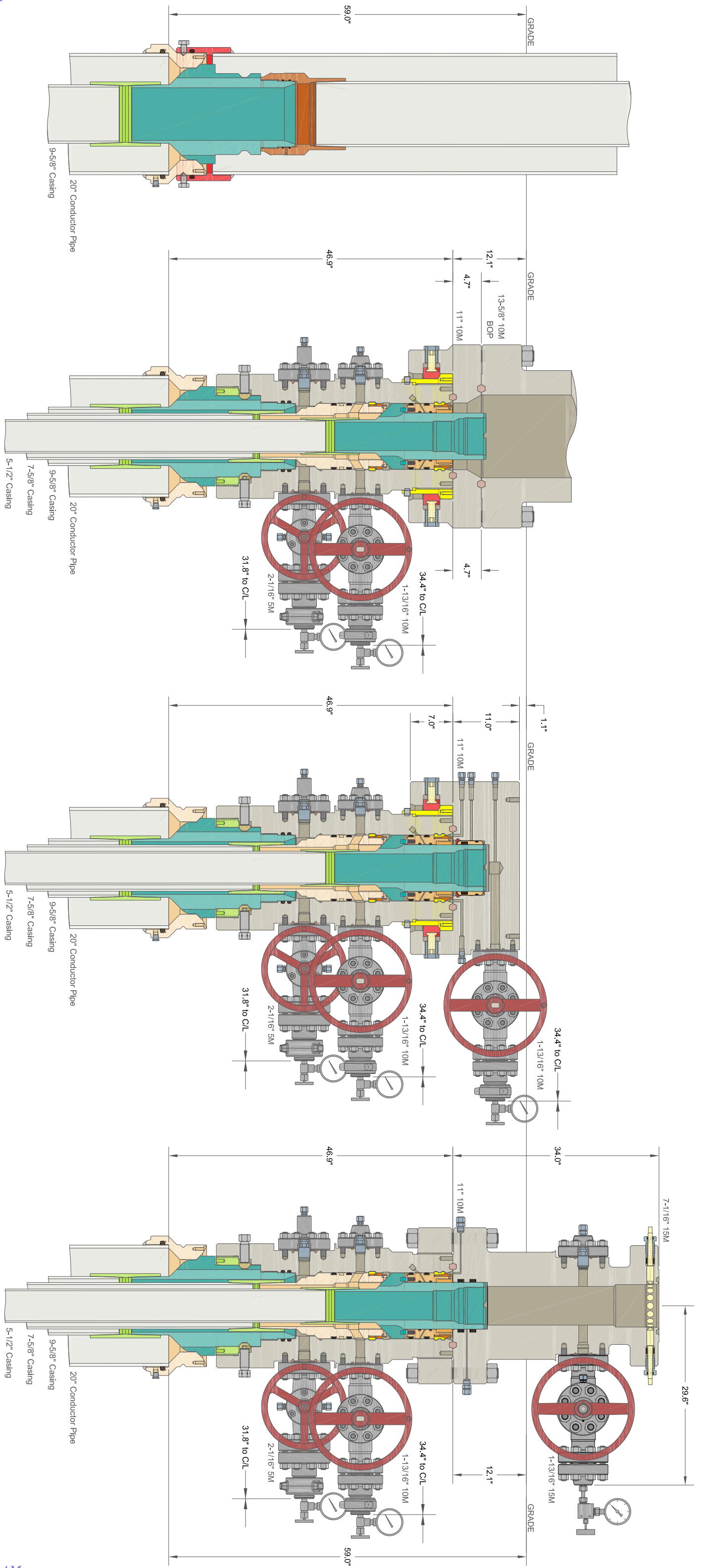

INFORMATION CONTAINED HEREIN IS THE PROPERTY OF CACTUS WELLHEAD, LLC. REPRODUCTION, DISCLOSURE, OR USE THEREOF IS PERMISSIBLE ONLY AS PROVIDED BY CONTRACT OR AS EXPRESSLY AUTHORIZED BY CACTUS WELLHEAD, LLC.

# CACTUS WELLHEAD LLC

20" x 9-5/8" x 7-5/8" x 5-1/2" MBU-T-CFL-R-DBLO Wellhead  
 With 1 1/4" 10M x 7-1/16" 15M CTH-DBLHPS Tubing Head  
 And 9-5/8", 7-5/8" & 5-1/2" Pin Bottom Mandrel Casing Hangers

ALL DIMENSIONS APPROXIMATE

XTO ENERGY INC  
 ICARUS PAD

DRAWN	DLE	18JAN21
APPRV		
DRAWING NO.	HBE0000479	

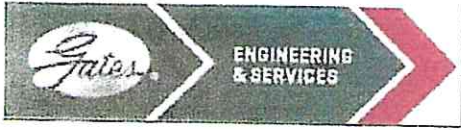

GATES E & S NORTH AMERICA, INC  
 DU-TEX  
 134 44TH STREET  
 CORPUS CHRISTI, TEXAS 78405

PHONE: 361-887-9807  
 FAX: 361-887-0812  
 EMAIL: crpe&s@gates.com  
 WEB: www.gates.com

**GRADE D PRESSURE TEST CERTIFICATE**

Customer :	AUSTIN DISTRIBUTING	Test Date:	6/8/2014
Customer Ref. :	PENDING	Hose Serial No.:	D-060814-1
Invoice No. :	201709	Created By:	NORMA

Product Description: FD3.042.0R41/16.5KFLGE/E LE

End Fitting 1 :	4 1/16 in.5K FLG	End Fitting 2 :	4 1/16 in.5K FLG
Gates Part No. :	4774-6001	Assembly Code :	L33090011513D-060814-1
Working Pressure :	5,000 PSI	Test Pressure :	7,500 PSI

Gates E & S North America, Inc. certifies that the following hose assembly has been tested to the Gates Oilfield Roughneck Agreement/Specification requirements and passed the 15 minute hydrostatic test per API Spec 7K/Q1, Fifth Edition, June 2010, Test pressure 9.6.7 and per Table 9 to 7,500 psi in accordance with this product number. Hose burst pressure 9.6.7.2 exceeds the minimum of 2.5 times the working pressure per Table 9.

Quality:	QUALITY	Technical Supervisor :	PRODUCTION
Date :	6/8/2014	Date :	6/8/2014
Signature :	<i>[Signature]</i>	Signature :	<i>[Signature]</i>

Form PTC - 01 Rev.0 2

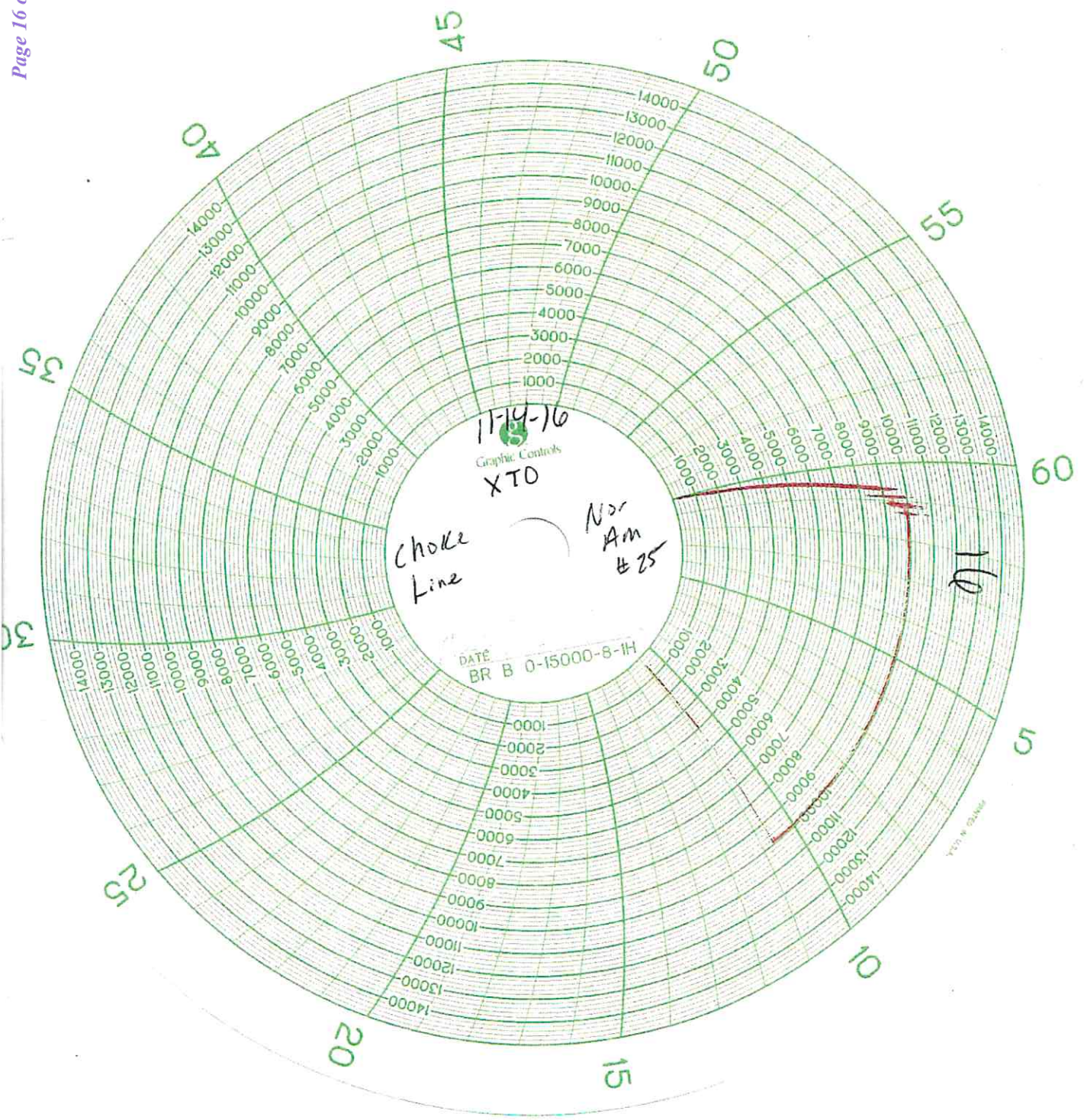

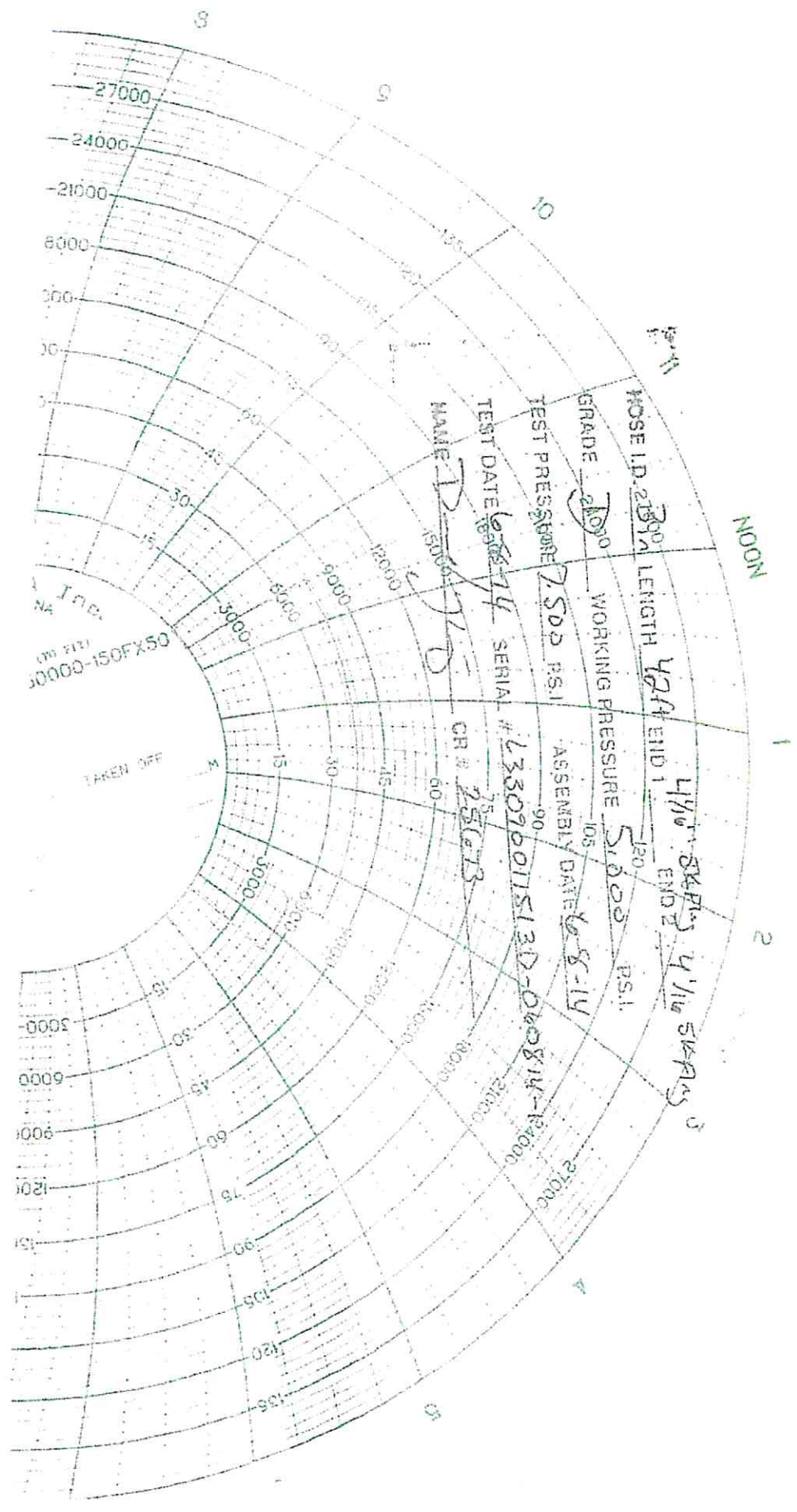

NA Inc.  
 (700 717)  
 10000-150FX50

TAKEN OFF

XTO respectfully requests approval to utilize a spudder rig to pre-set surface casing.

Description of Operations:

1. Spudder rig will move in to drill the surface hole and pre-set surface casing on the well.
  - a. After drilling the surface hole section, the spudder rig will run casing and cement following all of the applicable rules and regulations (OnShore Order 2, all COAs and NMOCD regulations).
  - b. The spudder rig will utilize fresh water-based mud to drill the surface hole to TD. Solids control will be handled entirely on a closed loop basis. No earth pits will be used.
2. The wellhead will be installed and tested as soon as the surface casing is cut off and WOC time has been reached.
3. A blind flange at the same pressure rating as the wellhead will be installed to seal the wellbore. Pressure will be monitored with needle valves installed on two wing valves.
  - a. A means for intervention will be maintained while the drilling rig is not over the well.
4. Spudder rig operations are expected to take 2-3 days per well on the pad.
5. The BLM will be contacted and notified 24 hours prior to commencing spudder rig operations.
6. Drilling Operations will begin with a larger rig and a BOP stack equal to or greater than the pressure rating that was permitted will be nipped up and tested on the wellhead before drilling operations resume on each well.
  - a. The larger rig will move back onto the location within 180 days from the point at which the wells are secured and the spudder rig is moved off location.
  - b. The BLM will be notified 24 hours before the larger rig moves back on the pre-set locations
7. XTO will have supervision on the rig to ensure compliance with all BLM and NMOCD regulations and to oversee operations.
8. Once the rig is removed, XTO will secure the wellhead area by placing a guard rail around the cellar area.

XTO respectfully requests approval to utilize a spudder rig to pre-set surface casing.

Description of Operations:

1. Spudder rig will move in to drill the surface hole and pre-set surface casing on the well.
  - a. After drilling the surface hole section, the spudder rig will run casing and cement following all of the applicable rules and regulations (OnShore Order 2, all COAs and NMOCD regulations).
  - b. The spudder rig will utilize fresh water-based mud to drill the surface hole to TD. Solids control will be handled entirely on a closed loop basis. No earth pits will be used.
2. The wellhead will be installed and tested as soon as the surface casing is cut off and WOC time has been reached.
3. A blind flange at the same pressure rating as the wellhead will be installed to seal the wellbore. Pressure will be monitored with needle valves installed on two wing valves.
  - a. A means for intervention will be maintained while the drilling rig is not over the well.
4. Spudder rig operations are expected to take 2-3 days per well on the pad.
5. The BLM will be contacted and notified 24 hours prior to commencing spudder rig operations.
6. Drilling Operations will begin with a larger rig and a BOP stack equal to or greater than the pressure rating that was permitted will be nipped up and tested on the wellhead before drilling operations resume on each well.
  - a. The larger rig will move back onto the location within 180 days from the point at which the wells are secured and the spudder rig is moved off location.
  - b. The BLM will be notified 24 hours before the larger rig moves back on the pre-set locations
7. XTO will have supervision on the rig to ensure compliance with all BLM and NMOCD regulations and to oversee operations.
8. Once the rig is removed, XTO will secure the wellhead area by placing a guard rail around the cellar area.

### XTO Permian Operating, LLC Offline Cementing Variance Request

XTO requests the option to cement the surface and intermediate casing strings offline as a prudent batch drilling efficiency of acreage development.

#### 1. Cement Program

No changes to the cement program will take place for offline cementing.

#### 2. Offline Cementing Procedure

The operational sequence will be as follows. If a well control event occurs, the BLM will be contacted for approval prior to conducting offline cementing operations.

1. Run casing as per normal operations. While running casing, conduct negative pressure test and confirm integrity of the float equipment (float collar and shoe)
2. Land casing with mandrel
3. Fill pipe with kill weight fluid, do not circulate through floats and confirm well is static
4. Set annular packoff shown below and pressure test to confirm integrity of the seal. Pressure ratings of wellhead components and valves is 5,000 psi.
5. After confirmation of both annular barriers and internal barriers, nipple down BOP and install cap flange.
  - a. If any barrier fails to test, the BOP stack will not be nipped down until after the cement job is completed with cement 500ft above the highest formation capable of flow with kill weight mud above or after it has achieved 50-psi compressive strength if kill weight fluid cannot be verified.

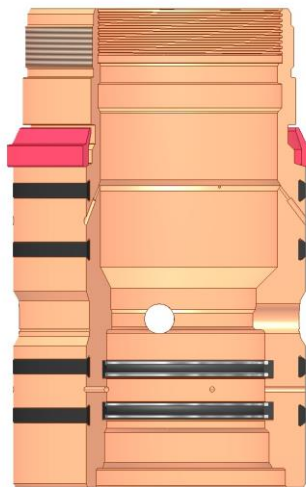

Annular packoff with both external and internal seals

## XTO Permian Operating, LLC Offline Cementing Variance Request

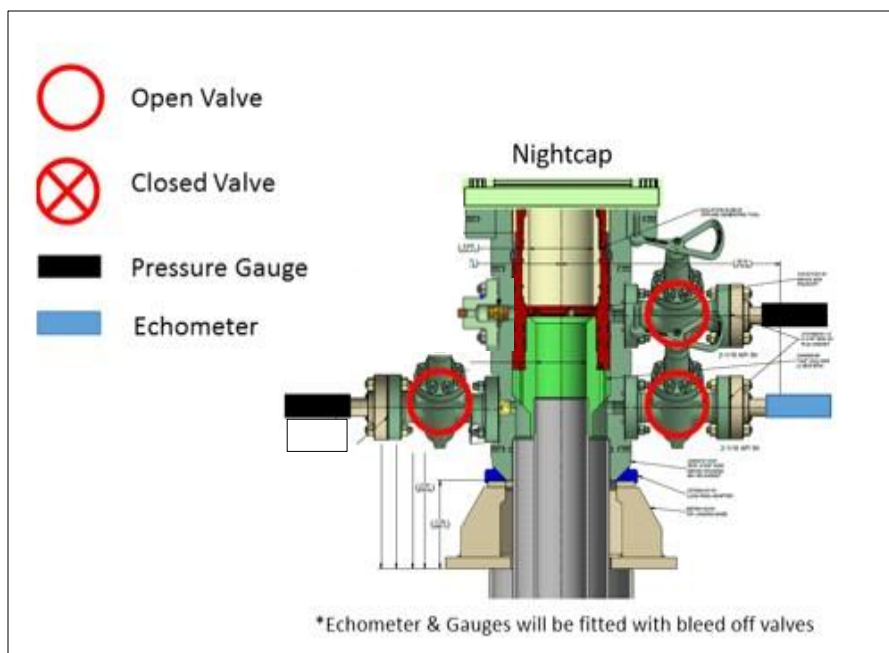

Wellhead diagram during skidding operations

6. Skid rig to next well on pad.
7. Confirm well is static before removing cap flange, flange will not be removed and offline cementing operations will not commence until well is under control. If well is not static, casing outlet valves will provide access to both the casing ID and annulus. Rig or third party pump truck will kill well prior to cementing or nipping up for further remediation.
  - a. Well Control Plan
    - i. The Drillers Method will be the primary well control method to regain control of the wellbore prior to cementing, if wellbore conditions do not permit the drillers method other methods of well control may be used
    - ii. Rig pumps or a 3<sup>rd</sup> party pump will be tied into the upper casing valve to pump down the casing ID
    - iii. A high pressure return line will be rigged up to lower casing valve and run to choke manifold to control annular pressure
    - iv. Once influx is circulated out of the hole, kill weight mud will be circulated
    - v. Well will be confirmed static
    - vi. Once confirmed static, cap flange will be removed to allow for offline cementing operations to commence
8. Install offline cement tool
9. Rig up cement equipment

**XTO Permian Operating, LLC Offline Cementing Variance Request**

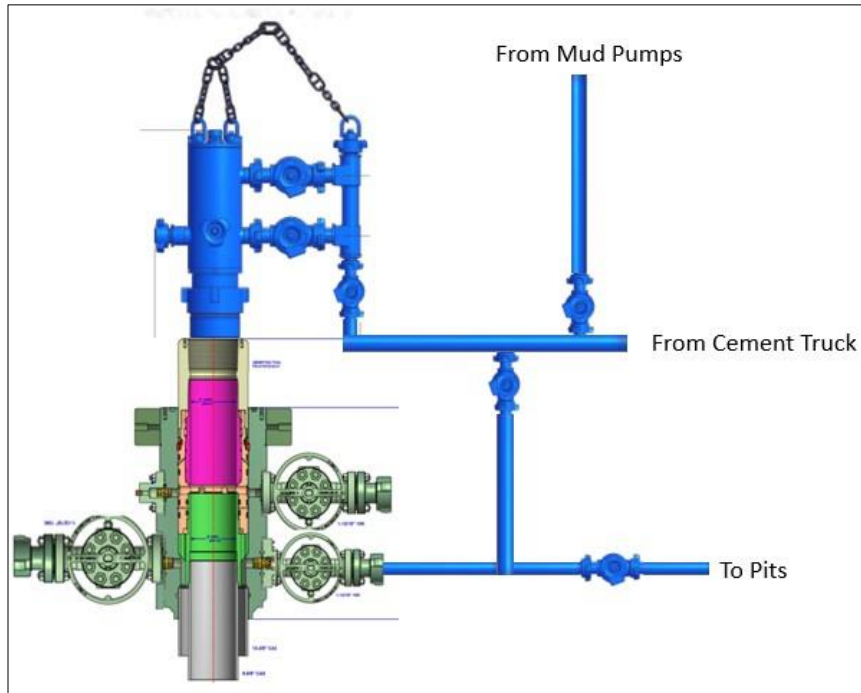

Wellhead diagram during offline cementing operations

10. Circulate bottoms up with cement truck
  - a. If gas is present on bottoms up, well will be shut in and returns rerouted through gas buster to handle entrained gas
  - b. Max anticipated time before circulating with cement truck is 6 hrs
11. Perform cement job taking returns from the annulus wellhead valve
12. Confirm well is static and floats are holding after cement job
13. Remove cement equipment, offline cement tools and install night cap with pressure gauge for monitoring.

### XTO Permian Operating, LLC Offline Cementing Variance Request

XTO requests the option to cement the surface and intermediate casing strings offline as a prudent batch drilling efficiency of acreage development.

#### 1. Cement Program

No changes to the cement program will take place for offline cementing.

#### 2. Offline Cementing Procedure

The operational sequence will be as follows. If a well control event occurs, the BLM will be contacted for approval prior to conducting offline cementing operations.

1. Run casing as per normal operations. While running casing, conduct negative pressure test and confirm integrity of the float equipment (float collar and shoe)
2. Land casing with mandrel
3. Fill pipe with kill weight fluid, do not circulate through floats and confirm well is static
4. Set annular packoff shown below and pressure test to confirm integrity of the seal. Pressure ratings of wellhead components and valves is 5,000 psi.
5. After confirmation of both annular barriers and internal barriers, nipple down BOP and install cap flange.
  - a. If any barrier fails to test, the BOP stack will not be nipped down until after the cement job is completed with cement 500ft above the highest formation capable of flow with kill weight mud above or after it has achieved 50-psi compressive strength if kill weight fluid cannot be verified.

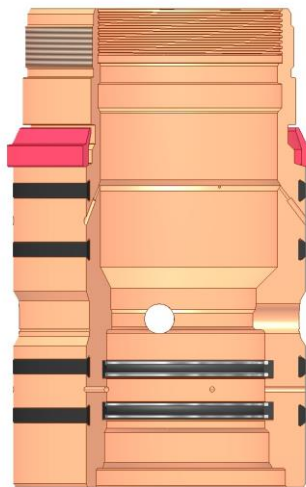

Annular packoff with both external and internal seals

## XTO Permian Operating, LLC Offline Cementing Variance Request

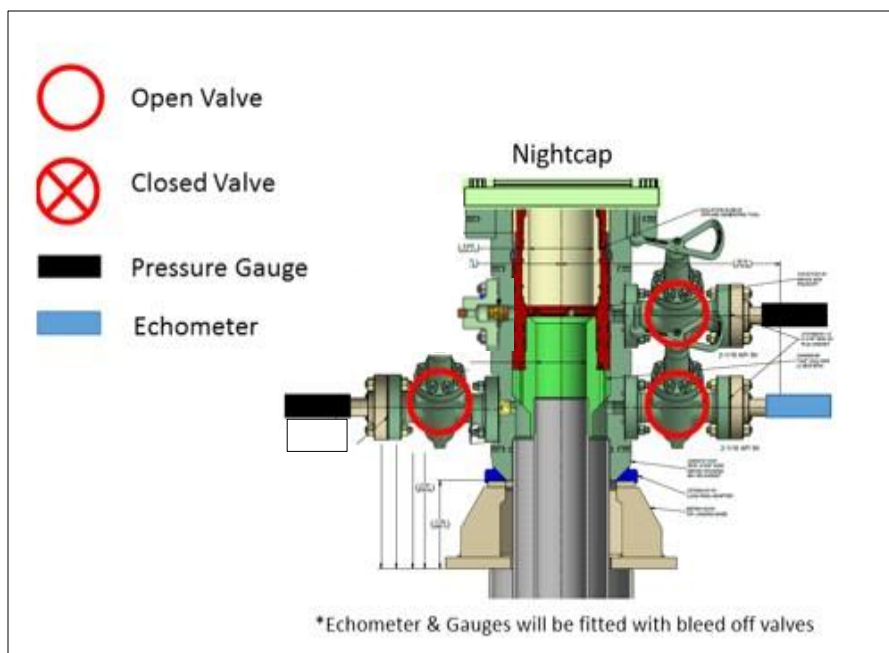

Wellhead diagram during skidding operations

6. Skid rig to next well on pad.
7. Confirm well is static before removing cap flange, flange will not be removed and offline cementing operations will not commence until well is under control. If well is not static, casing outlet valves will provide access to both the casing ID and annulus. Rig or third party pump truck will kill well prior to cementing or nipping up for further remediation.
  - a. Well Control Plan
    - i. The Drillers Method will be the primary well control method to regain control of the wellbore prior to cementing, if wellbore conditions do not permit the drillers method other methods of well control may be used
    - ii. Rig pumps or a 3<sup>rd</sup> party pump will be tied into the upper casing valve to pump down the casing ID
    - iii. A high pressure return line will be rigged up to lower casing valve and run to choke manifold to control annular pressure
    - iv. Once influx is circulated out of the hole, kill weight mud will be circulated
    - v. Well will be confirmed static
    - vi. Once confirmed static, cap flange will be removed to allow for offline cementing operations to commence
8. Install offline cement tool
9. Rig up cement equipment

**XTO Permian Operating, LLC Offline Cementing Variance Request**

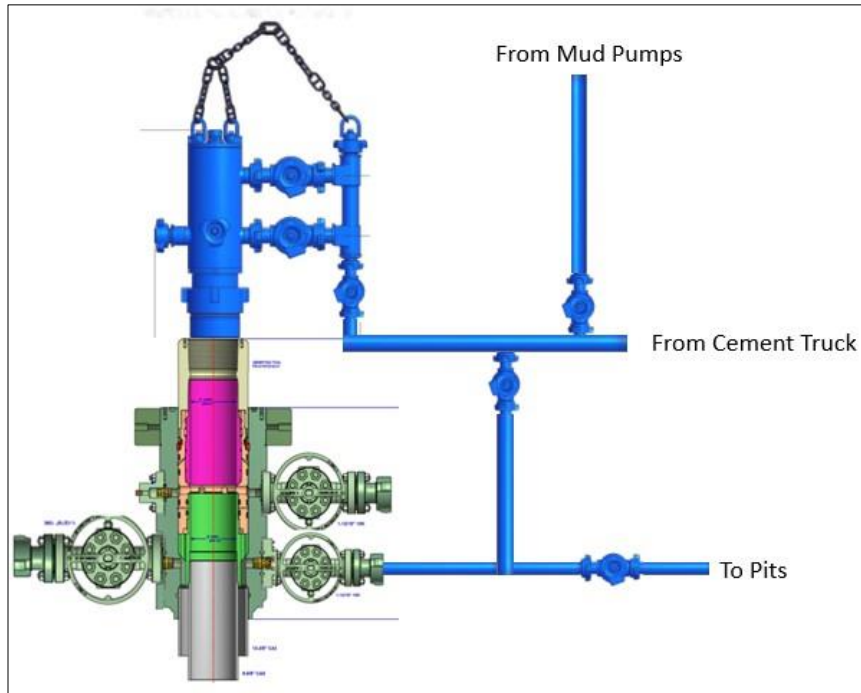

Wellhead diagram during offline cementing operations

10. Circulate bottoms up with cement truck
  - a. If gas is present on bottoms up, well will be shut in and returns rerouted through gas buster to handle entrained gas
  - b. Max anticipated time before circulating with cement truck is 6 hrs
11. Perform cement job taking returns from the annulus wellhead valve
12. Confirm well is static and floats are holding after cement job
13. Remove cement equipment, offline cement tools and install night cap with pressure gauge for monitoring.

**Subject:** Request for a Variance Allowing break Testing of the Blowout Preventer Equipment (BOPE)

XTO Energy requests a variance to ONLY test broken pressure seals on the BOPE and function test BOP when skidding a drilling rig between multiple wells on a pad.

### **Background**

Onshore Oil and Gas Order (OOGO) No. 2, Drilling Operations, Sections III.A.2.i.iv.B states that the BOP test must be performed whenever any seal subject to test pressure is broken. The current interpretation of the Bureau of Land Management (BLM) requires a complete BOP test and not just a test of the affected component. OOGO No. 2, Section I.D.2 states, "Some situation may exist either on a well-by-well basis or field-wide basis whereby it is commonly accepted practice to vary a particular minimum standard(s) established in this order. This situation can be resolved by requesting a variance...". XTO Energy feels the break testing the BOPE is such a situation. Therefore, as per OOGO No. 2, Section IV., XTO Energy submits this request for the variance.

### **Supporting Documentation**

OOGO No. 2 became effective on December 19, 1988 and has remained the standard for regulating BLM onshore drilling operations for over 30 years. During this time there have been significant changes in drilling technology. BLM continues to use the variance request process to allow for the use of modern technology and acceptable engineering practices that have arisen since OOGO No. 2 was originally released. The XTO Energy drilling rig fleet has many modern upgrades that allow the intact BOP stack to be moved between well slots on a multi-well pad, as well as, wellhead designs that incorporate quick connects facilitating release of the BOP from the wellhead without breaking any BOP stack components apart. These technologies have been used extensively offshore, and other regulators, API, and many operators around the world have endorsed break testing as safe and reliable.



Figure 1: Winch System attached to BOP Stack

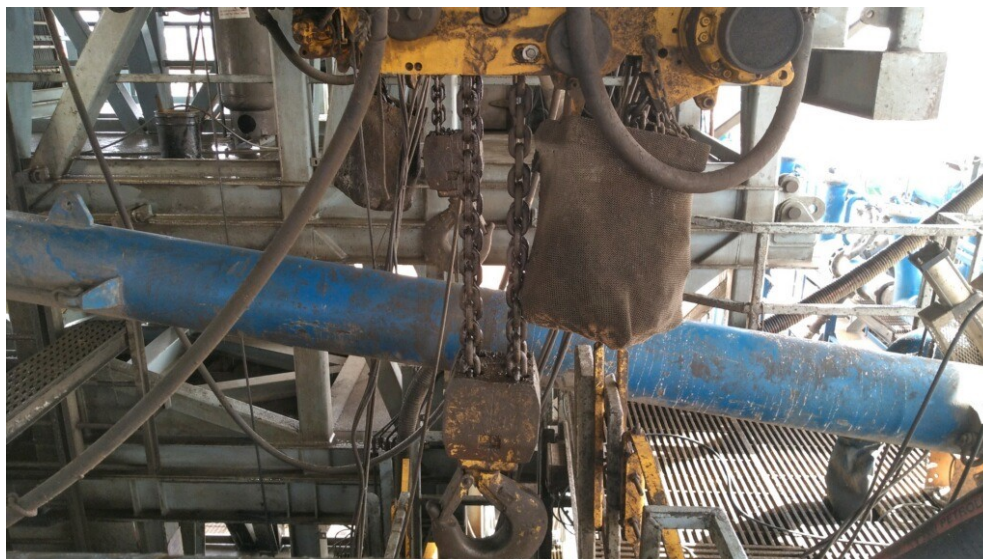

Figure 2: BOP Winch System

American Petroleum Institute (API) standards, specification and recommended practices are considered the industry standard and are consistently utilized and referenced by the industry. OOGO No. 2 recognizes API recommended Practices (RP) 53 in its original development. API Standard 53, *Well Control Equipment Systems for Drilling Wells* (Fifth Edition, December 2018, Annex C, Table C.4) recognizes break testing as an acceptable practice. Specifically, API Standard 53, Section 5.3.7.1 states “A pressure test of the pressure containing component shall be performed following the disconnection or repair, limited to the affected component.” See Table C.4 below for reference.

62 API STANDARD 53			
Table C.4—Initial Pressure Testing, Surface BOP Stacks			
Component to be Pressure Tested	Pressure Test—Low Pressure <sup>ac</sup> psig (MPa)	Pressure Test—High Pressure <sup>ac</sup>	
		Change Out of Component, Elastomer, or Ring Gasket	No Change Out of Component, Elastomer, or Ring Gasket
Annular preventer <sup>b</sup>	250 to 350 (1.72 to 2.41)	RWP of annular preventer	MASP or 70% annular RWP, whichever is lower.
Fixed pipe, variable bore, blind, and BSR preventers <sup>bd</sup>	250 to 350 (1.72 to 2.41)	RWP of ram preventer or wellhead system, whichever is lower	ITP
Choke and kill line and BOP side outlet valves below ram preventers (both sides)	250 to 350 (1.72 to 2.41)	RWP of side outlet valve or wellhead system, whichever is lower	ITP
Choke manifold—upstream of chokes <sup>e</sup>	250 to 350 (1.72 to 2.41)	RWP of ram preventers or wellhead system, whichever is lower	ITP
Choke manifold—downstream of chokes <sup>e</sup>	250 to 350 (1.72 to 2.41)	RWP of valve(s), line(s), or MASP for the well program, whichever is lower	
Kelly, kelly valves, drill pipe safety valves, IBOPs	250 to 350 (1.72 to 2.41)	MASP for the well program	
<sup>a</sup> Pressure test evaluation periods shall be a minimum of five minutes. No visible leaks. The pressure shall remain stable during the evaluation period. The pressure shall not decrease below the intended test pressure. <sup>b</sup> Annular(s) and VBR(s) shall be pressure tested on the largest and smallest OD drill pipe to be used in well program. <sup>c</sup> For pad drilling operations, moving from one wellhead to another within the 21 days, pressure testing is required for pressure-containing and pressure-controlling connections when the integrity of a pressure seal is broken. <sup>d</sup> For surface offshore operations, the ram BOPs shall be pressure tested with the ram locks engaged and the closing and locking pressure vented during the initial test. For land operations, the ram BOPs shall be pressure tested with the ram locks engaged and the closing and locking pressure vented at commissioning and annually. <sup>e</sup> Adjustable chokes are not required to be full sealing devices. Pressure testing against a closed choke is not required.			

The Bureau of Safety and Environmental Enforcement (BSEE), Department of Interior, has also utilized the API standards, specification and best practices in the development of its offshore oil and gas regulations and incorporates them by reference within its regulations.

Break testing has been approved by the BLM in the past with other operators based on the detailed information provided in this document.

XTO Energy feels break testing and our current procedures meet the intent of OOGO No. 2 and often exceed it. There has been no evidence that break testing results in more components failing than seen on full BOP tests. XTO Energy's internal standards requires complete BOPE tests more often than that of OOGO No. 2 (Every 21 days). In addition to function testing the annular, pipe rams and blind rams after each BOP nipple up, XTO Energy performs a choke drill with the rig crew prior to drilling out every casing shoe. This is additional training for the rig crew that exceeds the requirements of the OOGO No.2.

### **Procedures**

1. XTO Energy will use this document for our break testing plan for New Mexico Delaware basin. The summary below will be referenced in the APD or Sundry Notice and receive approval prior to implementing this variance.
2. XTO Energy will perform BOP break testing on multi-wells pads where multiple intermediate sections can be drilled and cased within the 21-day BOP test window.
  - a. A full BOP test will be conducted on the first well on the pad.
  - b. The first intermediate hole section drilled on the pad will be the deepest. All of the remaining hole sections will be the same depth or shallower.
    - i. Our Lower WC targets set the intermediate casing shoe no deeper than the Wolfcamp B.
    - ii. Our Upper WC targets set the intermediate casing shoe shallower than the Wolfcamp B.
  - c. A Full BOP test will be required if the intermediate hole section being drilled has a MASP over 5M.
  - d. A full BOP test will be required prior to drilling any production hole.
3. After performing a complete BOP test on the first well, the intermediate hole section will be drilled and cased, two breaks would be made on the BOP equipment.
  - a. Between the HCV valve and choke line connection
  - b. Between the BOP quick connect and the wellhead
4. The BOP is then lifted and removed from the wellhead by a hydraulic system.
5. After skidding to the next well, the BOP is moved to the wellhead by the same hydraulic system and installed.
6. The connections mentioned in 3a and 3b will then be reconnected.
7. Install test plug into the wellhead using test joint or drill pipe.
8. A shell test is performed against the upper pipe rams testing the two breaks.
9. The shell test will consist of a 250 psi low test and a high test to the value submitted in the APD or Sundry (e.g. 5,000 psi or 10,000psi).
10. Function test will be performed on the following components: lower pipe rams, blind rams, and annular.

11. For a multi-well pad the same two breaks on the BOP would be made and on the next wells and steps 4 through 10 would be repeated.
12. A second break test would only be done if the intermediate hole section being drilled could not be completed within the 21 day BOP test window.

*Note: Picture below highlights BOP components that will be tested during batch operations*

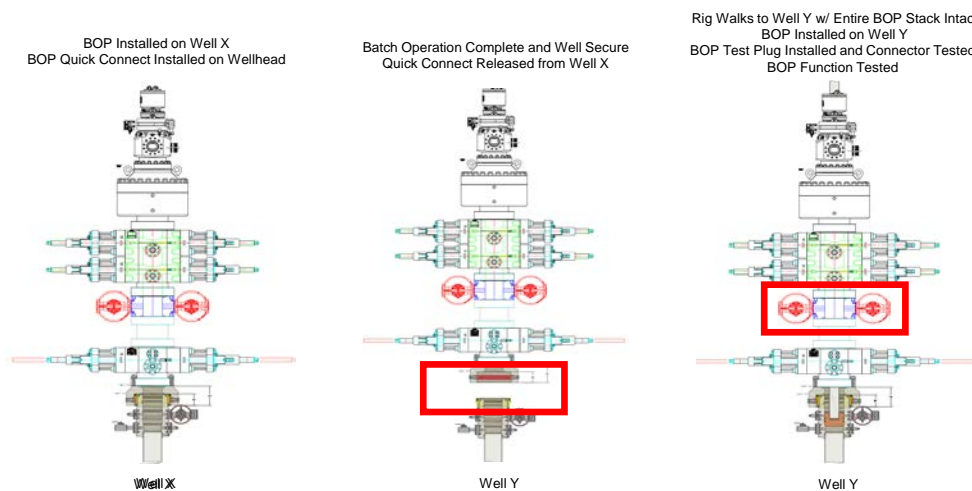

### Summary

A variance is requested to **ONLY** test broken pressure seals on the BOP equipment when moving from wellhead to wellhead which is in compliance with API Standard 53. API Standard 53 states, that for pad drilling operation, moving from one wellhead to another within 21 days, pressure testing is required for pressure-containing and pressure-controlling connections when the integrity of a pressure seal is broken.

The BOP will be secured by a hydraulic carrier or cradle. The BLM will be contacted if a Well Control event occurs prior to the commencement of a BOPE Break Testing operation.

Based on discussions with the BLM on February 27th 2020 and the supporting documentation submitted to the BLM, we will request permission to **ONLY** retest broken pressure seals if the following conditions are met:

1. After a full BOP test is conducted on the first well on the pad.
2. The first intermediate hole section drilled on the pad will be the deepest. All of the remaining hole sections will be the same depth or shallower.
3. Full BOP test will be required if the intermediate hole section being drilled has a MASP over 5M.
4. Full BOP test will be required prior to drilling the production hole.

Only **ONE** test will occur during each break test procedure.

All valves in red including the upper pipe rams will be shut to test the broken connections.  
\*\* Each valve on choke manifold will alternate being tested against during each rig skid.

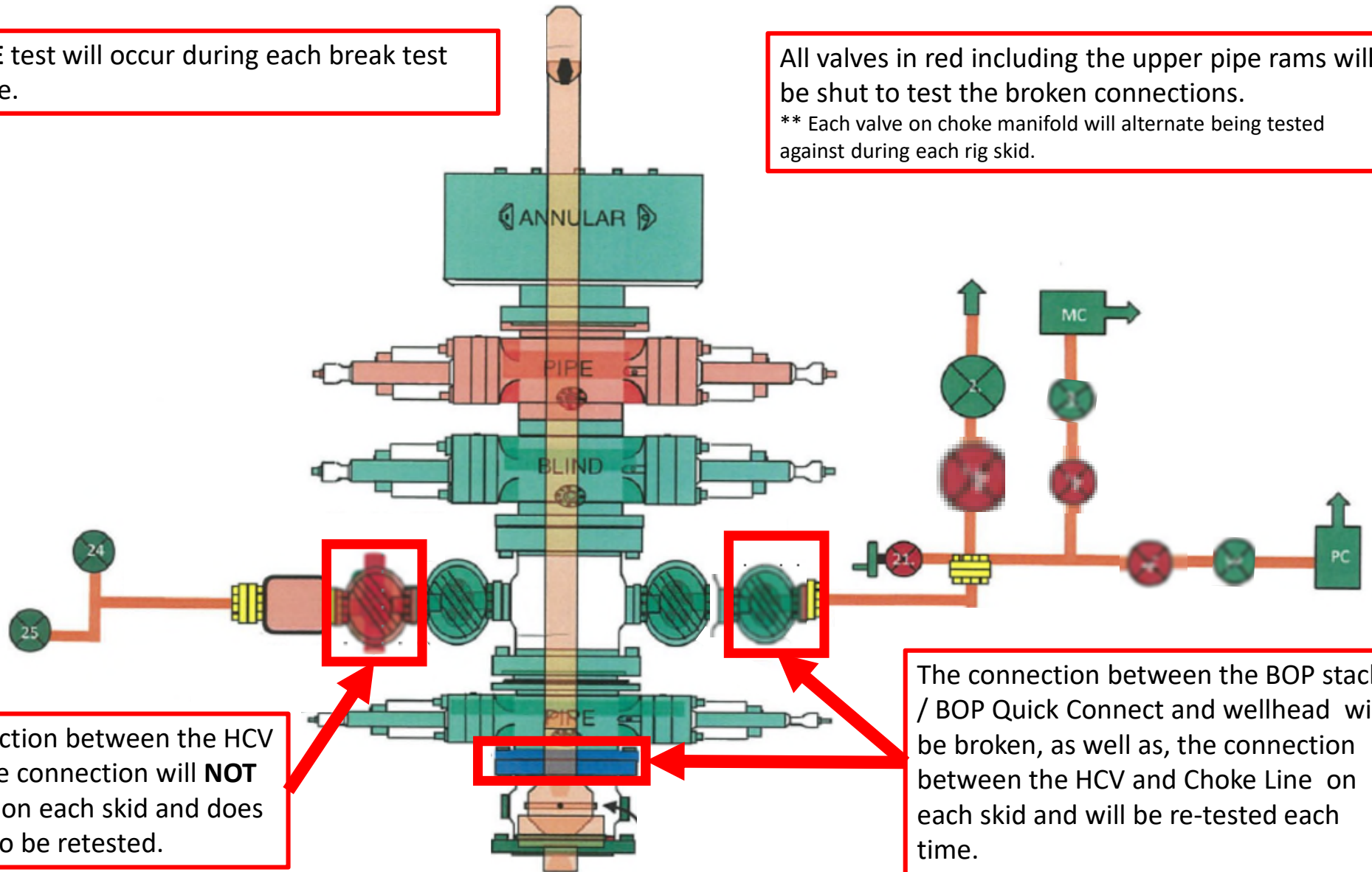

The connection between the HCV and kill line connection will **NOT** be broken on each skid and does not need to be retested.

The connection between the BOP stack / BOP Quick Connect and wellhead will be broken, as well as, the connection between the HCV and Choke Line on each skid and will be re-tested each time.

## PECOS DISTRICT DRILLING CONDITIONS OF APPROVAL

<b>OPERATOR'S NAME:</b>	<b>BOPCO, L.P.</b>
<b>LEASE NO.:</b>	<b>NMLC-065705B</b>
<b>WELL NAME &amp; NO.:</b>	<b>Muy Wayno 18 Federal 703H</b>
<b>SURFACE HOLE FOOTAGE:</b>	<b>2310' FSL &amp; 1990' FWL</b>
<b>BOTTOM HOLE FOOTAGE:</b>	<b>0200' FNL &amp; 2310' FWL Sec. 07, T. 25 S., R 30 E.</b>
<b>LOCATION:</b>	<b>Section 18, T. 25 S., R 30 E., NMPM</b>
<b>COUNTY:</b>	<b>Eddy County, New Mexico</b>

COA

H2S	<input type="radio"/> Yes	<input checked="" type="radio"/> No	
Potash	<input checked="" type="radio"/> None	<input type="radio"/> Secretary	<input type="radio"/> R-111-P
Cave/Karst Potential	<input checked="" type="radio"/> Low	<input type="radio"/> Medium	<input type="radio"/> High
Cave/Karst Potential	<input type="radio"/> Critical		
Variance	<input type="radio"/> None	<input checked="" type="radio"/> Flex Hose	<input type="radio"/> Other
Wellhead	<input type="radio"/> Conventional	<input checked="" type="radio"/> Multibowl	<input type="radio"/> Both
Other	<input type="checkbox"/> 4 String Area	<input type="checkbox"/> Capitan Reef	<input type="checkbox"/> WIPP
Other	<input checked="" type="checkbox"/> Fluid Filled	<input type="checkbox"/> Cement Squeeze	<input type="checkbox"/> Pilot Hole
Special Requirements	<input type="checkbox"/> Water Disposal	<input checked="" type="checkbox"/> COM	<input type="checkbox"/> Unit

**Possibility of water flows in the Castile and Salado.**  
**Possibility of lost circulation in the Red beds, Rustler, and Delaware.**  
**Abnormal pressures may be encountered when penetrating the 3<sup>rd</sup> Bone Spring Formation and all subsequent formations.**

**A. HYDROGEN SULFIDE**

Hydrogen Sulfide (H2S) monitors shall be installed prior to drilling out the surface shoe. If H2S is detected in concentrations greater than 100 ppm, the Hydrogen Sulfide area shall meet Onshore Order 6 requirements, which includes equipment and personnel/public protection items. If Hydrogen Sulfide is encountered, provide measured values and formations to the BLM.

## B. CASING

1. The **9-5/8** inch surface casing shall be set at approximately **890** feet (a minimum of 70 feet (Eddy County) into the Rustler Anhydrite and above the salt) and cemented to the surface.
  - a. If cement does not circulate to the surface, the appropriate BLM office shall be notified and a temperature survey utilizing an electronic type temperature survey with surface log readout will be used or a cement bond log shall be run to verify the top of the cement. Temperature survey will be run a minimum of six hours after pumping cement and ideally between 8-10 hours after completing the cement job.
  - b. Wait on cement (WOC) time for a primary cement job will be a minimum of **8 hours** or 500 pounds compressive strength, whichever is greater. (This is to include the lead cement)
  - c. Wait on cement (WOC) time for a remedial job will be a minimum of 4 hours after bringing cement to surface or 500 pounds compressive strength, whichever is greater.
  - d. If cement falls back, remedial cementing will be done prior to drilling out that string.

**Intermediate casing must be kept fluid filled to meet BLM minimum collapse requirement.**

2. The minimum required fill of cement behind the **7-5/8** inch intermediate casing is:
  - Cement as proposed. Report Echo meter results on subsequent sundry.
3. The minimum required fill of cement behind the **5-1/2 X 5** inch production casing is:
  - Cement should tie-back at least **200 feet** into previous casing string. Operator shall provide method of verification.

### C. PRESSURE CONTROL

1. Operator has proposed a multi-bowl wellhead assembly. This assembly will only be tested when installed on the surface casing. Minimum working pressure of the blowout preventer (BOP) and related equipment (BOPE) required for drilling below the surface casing shoe shall be **5000 (5M)** psi.
  - a. Wellhead shall be installed by manufacturer's representatives, submit documentation with subsequent sundry.
  - b. If the welding is performed by a third party, the manufacturer's representative shall monitor the temperature to verify that it does not exceed the maximum temperature of the seal.
  - c. Manufacturer representative shall install the test plug for the initial BOP test.
  - d. If the cement does not circulate and one inch operations would have been possible with a standard wellhead, the well head shall be cut off, cementing operations performed and another wellhead installed.
  - e. Whenever any seal subject to test pressure is broken, all the tests in OOGO2.III.A.2.i must be followed.

#### **BOP Break Testing Variance**

- Shell testing is not approved for any portion of the hole with a MASP of 5000 psi or greater.
- While in transfer between wells, the BOPE shall be secured by the hydraulic carrier or cradle.
- Any well control event while drilling require notification to the BLM Petroleum Engineer prior to the commencement of any BOP Break Testing operations.
- A full BOP test is required prior to drilling the first deep intermediate hole section. If any subsequent hole interval is deeper than the first, a full BOP test will be required.

#### **D. SPECIAL REQUIREMENT (S)**

##### **Operator to submit a sundry notice to add "COM" to the well name.**

##### **Communitization Agreement**

- The operator will submit a Communitization Agreement to the Carlsbad Field Office, 620 E Greene St. Carlsbad, New Mexico 88220, at least 90 days before the anticipated date of first production from a well subject to a spacing order issued by the New Mexico Oil Conservation Division. The Communitization Agreement will include the signatures of all working interest owners in all Federal and Indian leases subject to the Communitization Agreement (i.e., operating rights owners and lessees of record), or certification that the operator has obtained the written signatures of all such owners and will make those signatures available to the BLM immediately upon request.
- If the operator does not comply with this condition of approval, the BLM may take enforcement actions that include, but are not limited to, those specified in 43 CFR 3163.1.
- In addition, the well sign shall include the surface and bottom hole lease numbers. When the Communitization Agreement number is known, it shall also be on the sign.

## GENERAL REQUIREMENTS

The BLM is to be notified in advance for a representative to witness:

- a. Spudding well (minimum of 24 hours)
- b. Setting and/or Cementing of all casing strings (minimum of 4 hours)
- c. BOPE tests (minimum of 4 hours)

Eddy County

Call the Carlsbad Field Office, 620 East Greene St., Carlsbad, NM 88220,  
(575) 361-2822

1. Unless the production casing has been run and cemented or the well has been properly plugged, the drilling rig shall not be removed from over the hole without prior approval.
  - a. In the event the operator has proposed to drill multiple wells utilizing a skid/walking rig. Operator shall secure the wellbore on the current well, after installing and testing the wellhead, by installing a blind flange of like pressure rating to the wellhead and a pressure gauge that can be monitored while drilling is performed on the other well(s).
  - b. When the operator proposes to set surface casing with Spudder Rig
    - Notify the BLM when moving in and removing the Spudder Rig.
    - Notify the BLM when moving in the 2<sup>nd</sup> Rig. Rig to be moved in within 90 days of notification that Spudder Rig has left the location.
    - BOP/BOPE test to be conducted per Onshore Oil and Gas Order No. 2 as soon as 2nd Rig is rigged up on well.
2. Floor controls are required for 3M or Greater systems. These controls will be on the rig floor, unobstructed, readily accessible to the driller and will be operational at all times during drilling and/or completion activities. Rig floor is defined as the area immediately around the rotary table; the area immediately above the substructure on which the draw works are located, this does not include the dog house or stairway area.
3. The record of the drilling rate along with the GR/N well log run from TD to surface (horizontal well – vertical portion of hole) shall be submitted to the BLM office as well as all other logs run on the borehole 30 days from completion. If available, a digital copy of the logs is to be submitted in addition to the paper copies. The Rustler top and top and bottom of Salt are to be recorded on the Completion Report.

## A. CASING

1. Changes to the approved APD casing program need prior approval if the items substituted are of lesser grade or different casing size or are Non-API. The Operator can exchange the components of the proposal with that of superior strength (i.e. changing from J-55 to N-80, or from 36# to 40#). Changes to the approved cement program need prior approval if the altered cement plan has less volume or strength or if the changes are substantial (i.e. Multistage tool, ECP, etc.). The initial wellhead installed on the well will remain on the well with spools used as needed.
2. Wait on cement (WOC) for Water Basin: After cementing but before commencing any tests, the casing string shall stand cemented under pressure until both of the following conditions have been met: 1) cement reaches a minimum compressive strength of 500 psi at the shoe, 2) until cement has been in place at least 8 hours. WOC time will be recorded in the driller's log. See individual casing strings for details regarding lead cement slurry requirements. The casing integrity test can be done (prior to the cement setting up) immediately after bumping the plug.
3. Provide compressive strengths including hours to reach required 500 pounds compressive strength prior to cementing each casing string. Have well specific cement details onsite prior to pumping the cement for each casing string.
4. No pea gravel permitted for remedial or fall back remedial without prior authorization from the BLM engineer.
5. On that portion of any well approved for a 5M BOPE system or greater, a pressure integrity test of each casing shoe shall be performed. Formation at the shoe shall be tested to a minimum of the mud weight equivalent anticipated to control the formation pressure to the next casing depth or at total depth of the well. This test shall be performed before drilling more than 20 feet of new hole.
6. If hardband drill pipe is rotated inside casing, returns will be monitored for metal. If metal is found in samples, drill pipe will be pulled and rubber protectors which have a larger diameter than the tool joints of the drill pipe will be installed prior to continuing drilling operations.

## B. PRESSURE CONTROL

1. All blowout preventer (BOP) and related equipment (BOPE) shall comply with well control requirements as described in Onshore Oil and Gas Order No. 2 and API RP 53 Sec. 17.
2. If a variance is approved for a flexible hose to be installed from the BOP to the choke manifold, the following requirements apply: The flex line must meet the requirements of API 16C. Check condition of flexible line from BOP to choke manifold, replace if exterior is damaged or if line fails test. Line to be as straight as

possible with no hard bends and is to be anchored according to Manufacturer's requirements. The flexible hose can be exchanged with a hose of equal size and equal or greater pressure rating. Anchor requirements, specification sheet and hydrostatic pressure test certification matching the hose in service, to be onsite for review. These documents shall be posted in the company man's trailer and on the rig floor.

3. 5M or higher system requires an HCR valve, remote kill line and annular to match. The remote kill line is to be installed prior to testing the system and tested to stack pressure.
5. The appropriate BLM office shall be notified a minimum of 4 hours in advance for a representative to witness the tests.
  - a. In a water basin, for all casing strings utilizing slips, these are to be set as soon as the crew and rig are ready and any fallback cement remediation has been done. The casing cut-off and BOP installation can be initiated four hours after installing the slips, which will be approximately six hours after bumping the plug. For those casing strings not using slips, the minimum wait time before cut-off is eight hours after bumping the plug. BOP/BOPE testing can begin after cut-off or once cement reaches 500 psi compressive strength (including lead when specified), whichever is greater. However, if the float does not hold, cut-off cannot be initiated until cement reaches 500 psi compressive strength (including lead when specified).
  - b. The tests shall be done by an independent service company utilizing a test plug not a cup or J-packer. The operator also has the option of utilizing an independent tester to test without a plug (i.e. against the casing) pursuant to Onshore Order 2 with the pressure not to exceed 70% of the burst rating for the casing. Any test against the casing must meet the WOC time for water basin (8 hours) or potash (24 hours) or 500 pounds compressive strength, whichever is greater, prior to initiating the test (see casing segment as lead cement may be critical item).
  - c. The test shall be run on a 5000 psi chart for a 2-3M BOP/BOP, on a 10000 psi chart for a 5M BOP/BOPE and on a 15000 psi chart for a 10M BOP/BOPE. If a linear chart is used, it shall be a one hour chart. A circular chart shall have a maximum 2 hour clock. If a twelve hour or twenty-four hour chart is used, tester shall make a notation that it is run with a two hour clock.
  - d. The results of the test shall be reported to the appropriate BLM office.
  - e. All tests are required to be recorded on a calibrated test chart. A copy of the BOP/BOPE test chart and a copy of independent service company test will be submitted to the appropriate BLM office.

- f. The BOP/BOPE test shall include a low pressure test from 250 to 300 psi. The test will be held for a minimum of 10 minutes if test is done with a test plug and 30 minutes without a test plug. This test shall be performed prior to the test at full stack pressure.
- g. BOP/BOPE must be tested by an independent service company within 500 feet of the top of the Wolfcamp formation if the time between the setting of the intermediate casing and reaching this depth exceeds 20 days. This test does not exclude the test prior to drilling out the casing shoe as per Onshore Order No. 2.

#### C. DRILLING MUD

Mud system monitoring equipment, with derrick floor indicators and visual and audio alarms, shall be operating before drilling into the Wolfcamp formation, and shall be used until production casing is run and cemented.

#### D. WASTE MATERIAL AND FLUIDS

All waste (i.e. drilling fluids, trash, salts, chemicals, sewage, gray water, etc.) created as a result of drilling operations and completion operations shall be safely contained and disposed of properly at a waste disposal facility. No waste material or fluid shall be disposed of on the well location or surrounding area.

Porto-johns and trash containers will be on-location during fracturing operations or any other crew-intensive operations.

**JAM 07152021**



ACREAGE DEDICATION PLATS

This grid represents a standard section. You may superimpose a non-standard section, or larger area, over this grid. Operators must outline the dedicated acreage in a red box, clearly show the well surface location and bottom hole location, if it is directionally drilled, with the dimensions from the section lines in the cardinal directions. If this is a horizontal wellbore show on this plat the location of the First Take Point and Last Take Point, and the point within the completed interval (other than the First Take Point or Last Take Point) that is closest to any outer boundary of the tract.

Surveyors shall use the latest United States government survey or dependent resurvey. Well Locations will be in reference to the New Mexico Principal Meridian. If the land is not surveyed, contact the OCD Engineering Bureau. Independent subdivision surveys will not be accepted.

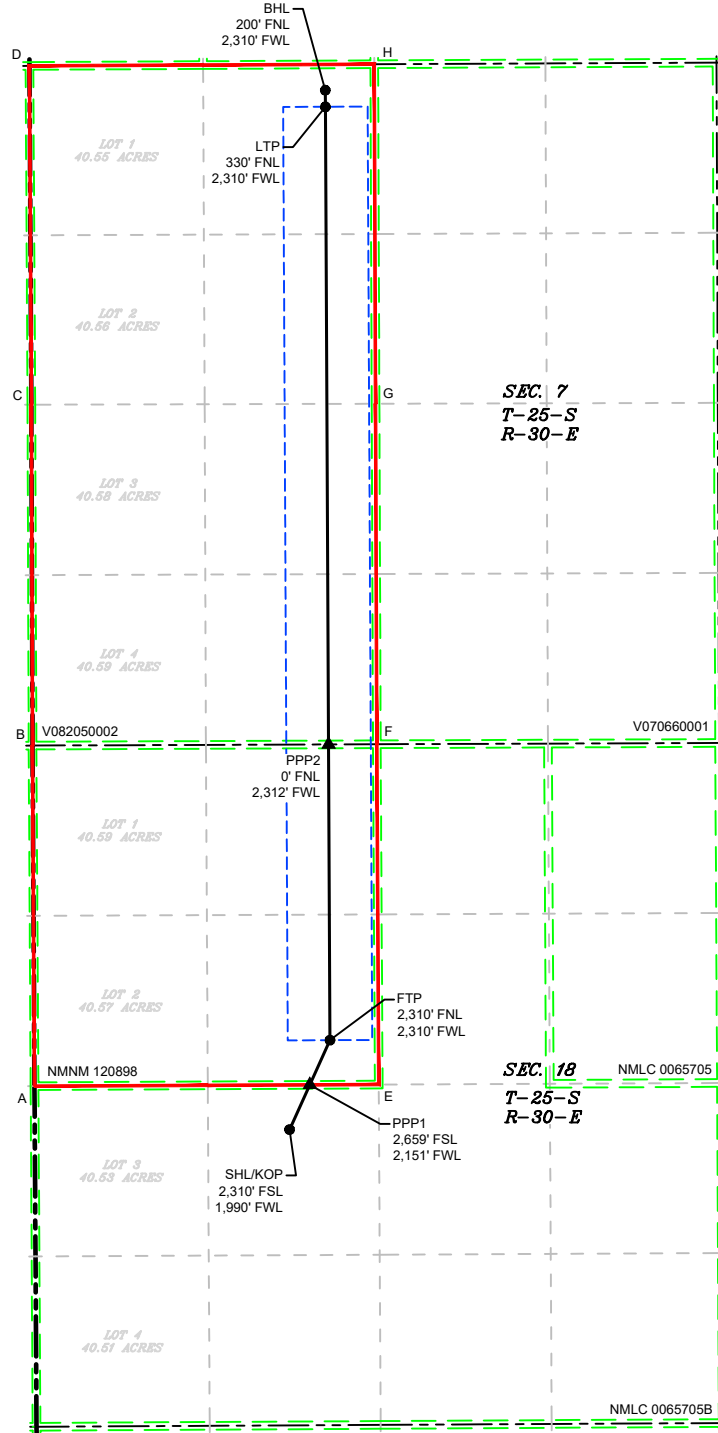

LEGEND

- SECTION LINE
- TOWNSHIP LINE
- DEDICATED ACREAGE
- 330' BUFFER
- MINERAL LEASE
- WELL BORE
- ▲ PPP
- WELL

WELL COORDINATE TABLE								
WELL	NAD 83 NME X	NAD 83 NME Y	NAD 83 LAT	NAD 83 LON	NAD 27 NME X	NAD 27 NME Y	NAD 27 LAT	NAD 27 LON
SHL/KOP	668,365.5	410,972.8	32.129178	-103.922975	627,181.0	410,914.3	32.129053	-103.922490
FTP	668,681.5	411,671.9	32.131097	-103.921946	627,497.0	411,613.3	32.130972	-103.921461
LTP	668,645.4	418,962.9	32.151139	-103.921972	627,461.1	418,904.2	32.151014	-103.921487
BHL	668,644.7	419,092.9	32.151496	-103.921973	627,460.4	419,034.1	32.151371	-103.921487
PPP1	668,523.6	411,322.6	32.130138	-103.922460	627,339.1	411,264.0	32.130013	-103.921975
PPP2	668,670.1	413,982.0	32.137447	-103.921954	627,485.6	413,923.4	32.137322	-103.921469

CORNER COORDINATE TABLE				
CORNER	NAD 83 NME X	NAD 83 NME Y	NAD 27 NME X	NAD 27 NME Y
A	666,372.8	411,312.7	625,188.3	411,254.2
B	666,357.8	413,973.3	625,173.4	413,914.7
C	666,348.2	416,635.7	625,163.9	416,577.0
D	666,334.0	419,282.2	625,149.8	419,223.4
E	669,062.3	411,325.1	627,877.7	411,266.5
F	669,047.2	413,983.4	627,862.8	413,924.8
G	669,037.3	416,642.9	627,852.9	416,584.2
H	669,027.3	419,295.1	627,843.0	419,236.4

F:\618.013 XTO Energy - NM\001 MUY Wayno 18 - Eddy\00 - MUY Wayno 18\Wells\19 - 163H\DWG\163H C-102.dwg  
 MUY WAYNO 18 FEDERAL 163H  
 Released to Imaging: 4/13/2026 9:34:34 AM

Sante Fe Main Office  
Phone: (505) 476-3441

General Information  
Phone: (505) 629-6116

Online Phone Directory  
<https://www.emnrd.nm.gov/ocd/contact-us>

**State of New Mexico**  
**Energy, Minerals and Natural Resources**  
**Oil Conservation Division**  
**1220 S. St Francis Dr.**  
**Santa Fe, NM 87505**

CONDITIONS

Action 571452

**CONDITIONS**

Operator: XTO ENERGY, INC 3617 North Big Spring Street Midland, TX 79705	OGRID: 5380
	Action Number: 571452
	Action Type: [C-103A] NOI Change of Plans (C-103A)

**CONDITIONS**

Created By	Condition	Condition Date
ward.rikala	None	4/13/2026