

U.S. Department of the Interior
BUREAU OF LAND MANAGEMENT

| | | |
|---|--|---|
| Well Name: TOP SPOT 12_13 FEDERAL | Well Location: T22S / R31E / SEC 13 / SESW / 32.384922 / -103.734953 | County or Parish/State: EDDY / NM |
| Well Number: 75H | Type of Well: OIL WELL | Allottee or Tribe Name: |
| Lease Number: NMNM29233 | Unit or CA Name: | Unit or CA Number: |
| US Well Number: | Operator: OXY USA INCORPORATED | |

Notice of Intent

Sundry ID: 2896450

Type of Submission: Notice of Intent

Type of Action: APD Change

Date Sundry Submitted: 02/18/2026

Time Sundry Submitted: 07:46

Date proposed operation will begin: 04/01/2026

Procedure Description: OXY USA Inc., respectfully requests to amend the subject AAPD to revise Drill Plan. Old Intermediate Casing: 11480' MD/11390' TVD New Intermediate Casing: 11883' MD/11777' TVD Old Intermediate 1S Tail - 622 sacks New Intermediate 1S Tail - 676 sacks Old Production Tail - 648 sacks, TOC @ 10980' New Production Tail - 625 sacks, TOC @ 11383' *THERE IS NO ADDITIONAL SURFACE DISTURBANCE RELATED TO THIS SUNDRY" Attached is the current C102, updated drill plan, updated variances and APD change worksheet.

NOI Attachments

Procedure Description

CombinedVariances_2026_20260219081739.pdf

TOPSPOT12_13FED75H_DrillPlan_20260219081731.pdf

TOPSPOT12_13FED75H_C102_20260219081725.pdf

TOPSPOT12_13FED75H_APDCHGSUNDRYWORKSHEET_20260219081716.pdf

Well Name: TOP SPOT 12_13
FEDERAL

Well Location: T22S / R31E / SEC 13 /
SESW / 32.384922 / -103.734953

County or Parish/State: EDDY /
NM

Well Number: 75H

Type of Well: OIL WELL

Allottee or Tribe Name:

Lease Number: NMNM29233

Unit or CA Name:

Unit or CA Number:

US Well Number:

Operator: OXY USA INCORPORATED

Operator

I certify that the foregoing is true and correct. Title 18 U.S.C. Section 1001 and Title 43 U.S.C. Section 1212, make it a crime for any person knowingly and willfully to make to any department or agency of the United States any false, fictitious or fraudulent statements or representations as to any matter within its jurisdiction. Electronic submission of Sundry Notices through this system satisfies regulations requiring a

Operator Electronic Signature: MELISSA GUIDRY

Signed on: FEB 19, 2026 08:17 AM

Name: OXY USA INCORPORATED

Title: Advisor Regulatory Sr.

Street Address: 5 GREENWAY PLAZA SUITE 110

City: HOUSTON

State: TX

Phone: (713) 497-2481

Email address: MELISSA_GUIDRY@OXY.COM

Field

Representative Name:

Street Address:

City:

State:

Zip:

Phone:

Email address:

BLM Point of Contact

BLM POC Name: KEITH P IMMATTY

BLM POC Title: ENGINEER

BLM POC Phone: 5759884722

BLM POC Email Address: KIMMATTY@BLM.GOV

Disposition: Approved

Disposition Date: 03/26/2026

Signature: KEITH IMMATTY

Form 3160-5
(October 2024)

UNITED STATES
DEPARTMENT OF THE INTERIOR
BUREAU OF LAND MANAGEMENT

FORM APPROVED
OMB No. 1004-0220
Expires: October 31, 2027

SUNDRY NOTICES AND REPORTS ON WELLS
Do not use this form for proposals to drill or to re-enter an abandoned well. Use Form 3160-3 (APD) for such proposals.

| | |
|--------------------------------------|-----------|
| 5. Lease Serial No. | NMNM29233 |
| 6. If Indian, Allottee or Tribe Name | |

| | | |
|--|---|--|
| SUBMIT IN TRIPLICATE - Other instructions on page 2 | | 7. If Unit of CA/Agreement, Name and/or No. |
| 1. Type of Well <input checked="" type="checkbox"/> Oil Well <input type="checkbox"/> Gas Well <input type="checkbox"/> Other | | 8. Well Name and No. TOP SPOT 12_13 FEDERAL/75H |
| 2. Name of Operator OXY USA INCORPORATED | | 9. API Well No. |
| 3a. Address 5 GREENWAY PLAZA SUITE 110, HOUSTON, TX | 3b. Phone No. (include area code) (713) 366-5716 | 10. Field and Pool or Exploratory Area WC 22S31E13/WOLFCAMP |
| 4. Location of Well (Footage, Sec., T., R., M., or Survey Description) SEC 13/T22S/R31E/NMP | | 11. Country or Parish, State EDDY/NM |

12. CHECK THE APPROPRIATE BOX(ES) TO INDICATE NATURE OF NOTICE, REPORT OR OTHER DATA

| TYPE OF SUBMISSION | TYPE OF ACTION | | | | |
|--|--|---|--|---|--|
| <input checked="" type="checkbox"/> Notice of Intent | <input type="checkbox"/> Acidize | <input type="checkbox"/> Deepen | <input type="checkbox"/> Production (Start/Resume) | <input type="checkbox"/> Water Shut-Off | |
| <input type="checkbox"/> Subsequent Report | <input type="checkbox"/> Alter Casing | <input type="checkbox"/> Hydraulic Fracturing | <input type="checkbox"/> Reclamation | <input type="checkbox"/> Well Integrity | |
| <input type="checkbox"/> Final Abandonment Notice | <input type="checkbox"/> Casing Repair | <input type="checkbox"/> New Construction | <input type="checkbox"/> Recomplete | <input type="checkbox"/> Other | |
| | <input checked="" type="checkbox"/> Change Plans | <input type="checkbox"/> Plug and Abandon | <input type="checkbox"/> Temporarily Abandon | | |
| | <input type="checkbox"/> Convert to Injection | <input type="checkbox"/> Plug Back | <input type="checkbox"/> Water Disposal | | |

13. Describe Proposed or Completed Operation: Clearly state all pertinent details, including estimated starting date of any proposed work and approximate duration thereof. If the proposal is to deepen directionally or recomplete horizontally, give subsurface locations and measured and true vertical depths of all pertinent markers and zones. Attach the Bond under which the work will be performed or provide the Bond No. on file with BLM/BIA. Required subsequent reports must be filed within 30 days following completion of the involved operations. If the operation results in a multiple completion or recompletion in a new interval, a Form 3160-4 must be filed once testing has been completed. Final Abandonment Notices must be filed only after all requirements, including reclamation, have been completed and the operator has determined that the site is ready for final inspection.)

OXY USA Inc., respectfully requests to amend the subject AAPD to revise Drill Plan.

Old Intermediate Casing: 11480' MD/11390' TVD
New Intermediate Casing: 11883' MD/11777' TVD

Old Intermediate 1S Tail - 622 sacks
New Intermediate 1S Tail - 676 sacks

Old Production Tail - 648 sacks, TOC @ 10980'
New Production Tail - 625 sacks, TOC @ 11383'

THERE IS NO ADDITIONAL SURFACE DISTURBANCE RELATED TO THIS SUNDRY

Continued on page 3 additional information

| | |
|--|---------------------------------|
| 14. I hereby certify that the foregoing is true and correct. Name (Printed/Typed) MELISSA GUIDRY / Ph: (713) 497-2481 | Advisor Regulatory Sr. Title |
| Signature (Electronic Submission) | Date 02/19/2026 |

THE SPACE FOR FEDERAL OR STATE OFFICE USE

| | | |
|---|-------------------|--------------------|
| Approved by KEITH P IMMATTY / Ph: (575) 988-4722 / Approved | ENGINEER Title | 03/26/2026 Date |
| Conditions of approval, if any, are attached. Approval of this notice does not warrant or certify that the applicant holds legal or equitable title to those rights in the subject lease which would entitle the applicant to conduct operations thereon. | Office CARLSBAD | |

Title 18 U.S.C Section 1001 and Title 43 U.S.C Section 1212, make it a crime for any person knowingly and willfully to make to any department or agency of the United States any false, fictitious or fraudulent statements or representations as to any matter within its jurisdiction.

(Instructions on page 2)

GENERAL INSTRUCTIONS

This form is designed for submitting proposals to perform certain well operations and reports of such operations when completed as indicated on Federal and Indian lands pursuant to applicable Federal law and regulations. Any necessary special instructions concerning the use of this form and the number of copies to be submitted, particularly with regard to local area or regional procedures and practices, are either shown below, will be issued by or may be obtained from the local Federal office.

SPECIFIC INSTRUCTIONS

Item 4 - Locations on Federal or Indian land should be described in accordance with Federal requirements. Consult the local Federal office for specific instructions.

Item 13: Proposals to abandon a well and subsequent reports of abandonment should include such special information as is required by the local Federal office. In addition, such proposals and reports should include reasons for the abandonment; data on any former or present productive zones or other zones with present significant fluid contents not sealed off by cement or otherwise; depths (top and bottom) and method of placement of cement plugs; mud or other material placed below, between and above plugs; amount, size, method of parting of any casing, liner or tubing pulled and the depth to the top of any tubing left in the hole; method of closing top of well and date well site conditioned for final inspection looking for approval of the abandonment. If the proposal will involve **hydraulic fracturing operations**, you must comply with 43 CFR 3162.3-3, including providing information about the protection of usable water. Operators should provide the best available information about all formations containing water and their depths. This information could include data and interpretation of resistivity logs run on nearby wells. Information may also be obtained from state or tribal regulatory agencies and from local BLM offices.

NOTICES

The privacy Act of 1974 and the regulation in 43 CFR 2.48(d) provide that you be furnished the following information in connection with information required by this application.

AUTHORITY: 30 U.S.C. 181 et seq., 351 et seq., 25 U.S.C. 396; 43 CFR 3160.

PRINCIPAL PURPOSE: The information is used to: (1) Evaluate, when appropriate, approve applications, and report completion of subsequent well operations, on a Federal or Indian lease; and (2) document for administrative use, information for the management, disposal and use of National Resource lands and resources, such as: (a) evaluating the equipment and procedures to be used during a proposed subsequent well operation and reviewing the completed well operations for compliance with the approved plan; (b) requesting and granting approval to perform those actions covered by 43 CFR 3162.3-2, 3162.3-3, and 3162.3-4; (c) reporting the beginning or resumption of production, as required by 43 CFR 3162.4-1(c) and (d) analyzing future applications to drill or modify operations in light of data obtained and methods used.

ROUTINE USES: Information from the record and/or the record will be transferred to appropriate Federal, State, local or foreign agencies, when relevant to civil, criminal or regulatory investigations or prosecutions in connection with congressional inquiries or to consumer reporting agencies to facilitate collection of debts owed the Government.

EFFECT OF NOT PROVIDING THE INFORMATION: Filing of this notice and report and disclosure of the information is mandatory for those subsequent well operations specified in 43 CFR 3162.3-2, 3162.3-3, 3162.3-4.

The Paperwork Reduction Act of 1995 requires us to inform you that:

The BLM collects this information to evaluate proposed and/or completed subsequent well operations on Federal or Indian oil and gas leases.

Response to this request is mandatory.

The BLM would like you to know that you do not have to respond to this or any other Federal agency-sponsored information collection unless it displays a currently valid OMB control number.

BURDEN HOURS STATEMENT: Public reporting burden for this form is estimated to average 8 hours per response, including the time for reviewing instructions, gathering and maintaining data, and completing and reviewing the form. Direct comments regarding the burden estimate or any other aspect of this form to U.S. Department of the Interior, Bureau of Land Management (1004-0137), Bureau Information Collection Clearance Officer (WO-630), 1849 C St., N.W., Mail Stop 401 LS, Washington, D.C. 20240

Additional Information

Additional Remarks

Attached is the current C102, updated drill plan, updated variances and APD change worksheet.

Location of Well

0. SHL: SESW / 245 FSL / 1580 FWL / TWSP: 22S / RANGE: 31E / SECTION: 13 / LAT: 32.384922 / LONG: -103.734953 (TVD: 0 feet, MD: 0 feet)

PPP: SWSW / 100 FSL / 440 FWL / TWSP: 22S / RANGE: 31E / SECTION: 13 / LAT: 32.384522 / LONG: -103.738646 (TVD: 12073 feet, MD: 12498 feet)

BHL: NWNW / 20 FNL / 440 FWL / TWSP: 22S / RANGE: 31E / SECTION: 12 / LAT: 32.413251 / LONG: -103.738631 (TVD: 12073 feet, MD: 22428 feet)

Oxy Combined Variances - Table of Contents

| | |
|---|----|
| 5MAnnBOPVariance.pdf | 2 |
| BOPBreakTestingVariance2026.pdf | 6 |
| BradenheadCBLVariance.pdf | 7 |
| FalconSL1AnnClearanceVariance.pdf | 8 |
| ProdCsgAnnClearanceVariance.pdf | 9 |
| OfflineIntermediateCementVariance.pdf | 10 |
| Oxy-BLM Offline Production Cementing rev2.pdf | 13 |
| SpudRigData.pdf | 24 |

5M Annular BOP Variance Request

Per BLM's Memorandum No. NM-2017-008: *Decision and Rationale for a Variance Allowing the Use of a 5M Annular Preventer with a 10M BOP Stack*, Oxy requests to employ a 5M annular with a 10M BOPE stack in the pilot and lateral sections of the well and will ensure that two barriers to flow are maintained at all times. Please see Well Control Plan below.

Oxy Well Control Plan

A. Component and Preventer Compatibility Table

The table below, which covers the drilling and casing of the >5M MASP portion of the well, outlines the tubulars and the compatible preventers in use. This table, combined with the mud program, documents that two barriers to flow can be maintained at all times, independent of the rating of the annular preventer.

Pilot hole and Lateral sections, 10M requirement

| Component | OD | Preventer | RWP |
|-----------------------------|-----------------|--|-----|
| Drillpipe | 4-1/2"-5" | Lower 3-1/2 - 5-1/2" VBR Upper 3-1/2 - 5-1/2" VBR | 10M |
| HWDP | 4-1/2"-5" | Lower 3-1/2 - 5-1/2" VBR Upper 3-1/2 - 5-1/2" VBR | 10M |
| Drill collars and MWD tools | 4-3/4" – 5-1/2" | Lower 3-1/2 - 5-1/2" VBR Upper 3-1/2 - 5-1/2" VBR | 10M |
| Mud Motor | 4-3/4" | Lower 3-1/2 - 5-1/2" VBR Upper 3-1/2 - 5-1/2" VBR | 10M |
| Production casing | 5-1/2" | Lower 3-1/2 - 5-1/2" VBR Upper 3-1/2 - 5-1/2" VBR | 10M |
| ALL | 0" - 13-5/8" | Annular | 5M |
| Open-hole | 6-3/4" | Blind Rams | 10M |

VBR = Variable Bore Ram. Compatible range listed in chart.

HWDP = Heavy Weight Drill Pipe

MWD = Measurement While Drilling

B. Well Control Procedures

Well control procedures are specific to the rig equipment and the operation at the time the kick occurs. Below are the minimal high-level tasks prescribed to assure a proper shut-in while drilling, tripping, running casing, pipe out of the hole (open hole), and moving the Bottom Hole Assembly (BHA) through the Blowout Preventers (BOP). The pressure at which control is swapped from the annular to another compatible ram will occur when the anticipated pressure is approaching or envisioned to exceed 70% of the 5M annular Rated Working Pressure (RWP) or 3500 PSI.

General Procedure While Drilling

1. Sound alarm (alert crew)
2. Space out drill string
3. Shut down pumps (stop pumps and rotary)
4. Shut-in Well (uppermost applicable BOP, typically annular preventer first. The Hydraulic Control Remote (HCR) valve and choke will already be in the closed position).
5. Confirm shut-in
6. Notify tool pusher/company representative
7. Read and record the following:
 - a. SIDPP and SICP
 - b. Pit gain
 - c. Time
8. Regroup and identify forward plan
9. If pressure has built or expected to reach 70% of the annular RWP during kill operations, crew will reconfirm spacing and swap to the upper pipe ram

General Procedure While Tripping

1. Sound alarm (alert crew)
2. Stab full opening safety valve and close
3. Space out drill string
4. Shut-in (uppermost applicable BOP, typically annular preventer first. The HCR and choke will already be in the closed position)
5. Confirm shut-in
6. Notify tool pusher/company representative
7. Read and record the following
 - a. SIDPP and SICP
 - b. Pit gain
 - c. Time
 - d. Regroup and identify forward plan
 - e. If pressure has built or is anticipated during the kill to reach the RWP of the annular preventer, confirm spacing and swap to the upper pipe ram

General Procedure While Running Casing

1. Sound alarm (alert crew)
2. Stab crossover and full opening safety valve and close
3. Space out string
4. Shut-in (uppermost applicable BOP, typically annular preventer first. The HCR and choke will already be in the closed position).
5. Confirm shut-in
6. Notify tool pusher/company representative
7. Read and record the following:
 - a. SIDPP and SICP
 - b. Pit gain
 - c. Time
 - d. Regroup and identify forward plan.
 - e. If pressure has built or is anticipated during the kill to reach the RWP of the annular preventer, confirm spacing and swap to compatible pipe ram.

General Procedure With No Pipe In Hole (Open Hole)

1. Sound alarm (alert crew)
2. Shut-in with blind rams or BSR. (The HCR and choke will already be in the closed position)
3. Confirm shut-in
4. Notify tool pusher/company representative
5. Read and record the following:
 - a. SICP
 - b. Pit gain
 - c. Time
6. Regroup and identify forward plan

General Procedures While Pulling BHA thru Stack

1. PRIOR to pulling last joint of drill pipe thru the stack.
 - a. Perform flow check, if flowing:
 - b. Sound alarm (alert crew)
 - c. Stab full opening safety valve and close
 - d. Space out drill string with tool joint just beneath the upper pipe ram
 - e. Shut-in using upper pipe ram. (The HCR and choke will already be in the closed position)
 - f. Confirm shut-in
 - g. Notify tool pusher/company representative
 - h. Read and record the following:
 - i. SIDPP and SICP
 - ii. Pit gain
 - iii. Time
 - iv. Regroup and identify forward plan
2. With BHA in the stack and compatible ram preventer and pipe combo immediately available.
 - a. Sound alarm (alert crew)
 - b. Stab crossover and full opening safety valve and close
 - c. Space out drill string with upset just beneath the compatible pipe ram
 - d. Shut-in using compatible pipe ram. (The HCR and choke will already be in the closed position.)
 - e. Confirm shut-in
 - f. Notify tool pusher/company representative
 - g. Read and record the following:
 - i. SIDPP and SICP
 - ii. Pit gain
 - iii. Time
 - iv. Regroup and identify forward plan
3. With BHA in the stack and NO compatible ram preventer and pipe combo immediately available.

- a. Sound alarm (alert crew)
- b. If possible to pick up high enough, pull string clear of the stack and follow “Open Hole” scenario
- c. If impossible to pick up high enough to pull the string clear of the stack
- d. Stab crossover, make up one joint/stand of drill pipe, and full opening safety valve and close
- e. Space out drill string with tool joint just beneath the upper pipe ram
- f. Shut-in using upper pipe ram. (The HCR and choke will already be in the closed position)
- g. Confirm shut-in
- h. Notify tool pusher/company representative
- i. Read and record the following:
 - i. SIDPP and SICP
 - ii. Pit gain
 - iii. Time
- j. Regroup and identify forward plan

BOP Break Testing Request

Oxy requests permission to adjust the BOP break testing requirements as per the agreement reached with OXY/BLM on January 22nd, 2026.

BOPE Break Testing is ONLY permitted for 5M MASP or less on wells that are in the Wolfcamp formation or shallower. If the MASP approaches 10% of the rated working pressure of a 5M system, the BOPE must be tested to 10M and annular to 5M.

BOP break test for the **intermediate or production** section under the following conditions:

- After a full BOP test is conducted.
- When skidding to drill an intermediate or production section which does not penetrate the deeper than the Wolfcamp formation ($\leq 5M$ MASP).
- In the event any repairs or replacement of the BOPE is required, the BOPE shall test as per 3 CFR part 3170 Subpart 3172
- While in transfer between wells, the BOPE shall be secured by the hydraulic carrier or cradle.
- In the event break testing is not utilized, then a full BOPE test would be conducted.
- If the kill line is broken prior to skid, two tests will be performed.
 - 1) Wellhead flange, co-flex hose, kill line connections and upper pipe rams
 - 2) Wellhead flange, HCR valve, check valve, upper pipe rams
- If the kill line is not broken prior to skid, only one test will be performed.
 - 1) Wellhead flange, co-flex hose, check valve, upper pipe rams

Bradenhead Cement CBL Variance Request

Oxy requests permission to adjust the CBL requirement after bradenhead cement jobs, on 7-5/8” intermediate casings, as per the agreement reached in the OXY/BLM meeting on September 5, 2019.

Three string wells:

- CBL will be required on one well per pad
- If the pumped volume of cement is less than permitted in the APD, BLM will be notified and a CBL may be run
- Echometer will be used after bradenhead cement job to determine TOC before pumping top-out cement

Four string wells:

- CBL is not required
- If the pumped volume of cement is less than permitted in the APD, BLM will be notified and a CBL may be run
- Echometer will be used after bradenhead cement job to determine TOC before pumping top-out cement

Falcon SL1 Production Casing Annular Clearance Variance Request

If Production Casing Connection OD does not meet 0.422" annular clearance inside casing:

- Cement excess will be circulated from Top of Liner to surface (Cement Confirmation)
- Liner Top will be tested to confirm seal.
- If ICP in Bone Spring Pool and lateral landed in Wolfcamp Pool, a CBL will be ran.

Production Casing Annular Clearance Variance Request

As per the agreement reached in the Oxy/BLM face-to-face meeting on Feb 22, 2018, Oxy requests permission to allow deviation from the 0.422" annular clearance requirement from 43 CFR part 3170 Subpart 3172 under the following conditions:

1. Annular clearance to meet or exceed 0.422" between intermediate casing ID and production casing coupling only on the first 500' overlap between both casings.
2. Annular clearance less than 0.422" is acceptable for the curve and lateral portions of the production open hole section.

Offline Intermediate Cementing Variance Request

Oxy requests a variance to cement the 9.625" and/or 7.625" intermediate casing strings offline in accordance to the approved variance, EC Tran 461365.

1. Cement Program

No changes to the cement program will take place for offline cementing.

2. Offline Cementing Procedure

The operational sequence will be as follows:

1. Run casing as per normal operations. While running casing, conduct negative pressure test and confirm integrity of the float equipment (float collar and shoe)
2. Land casing with mandrel
3. Fill pipe with kill weight fluid, do not circulate through floats and confirm well is static
4. Set annular packoff shown below and pressure test to confirm integrity of the seal.
Pressure ratings of wellhead components and valves is 5,000 psi

Annular packoff with both external and internal seals

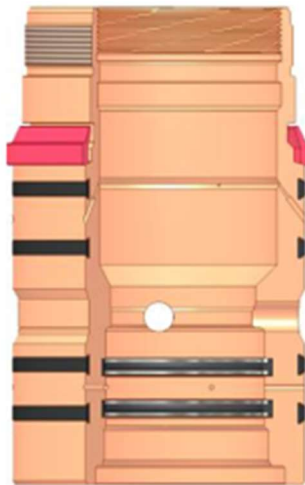

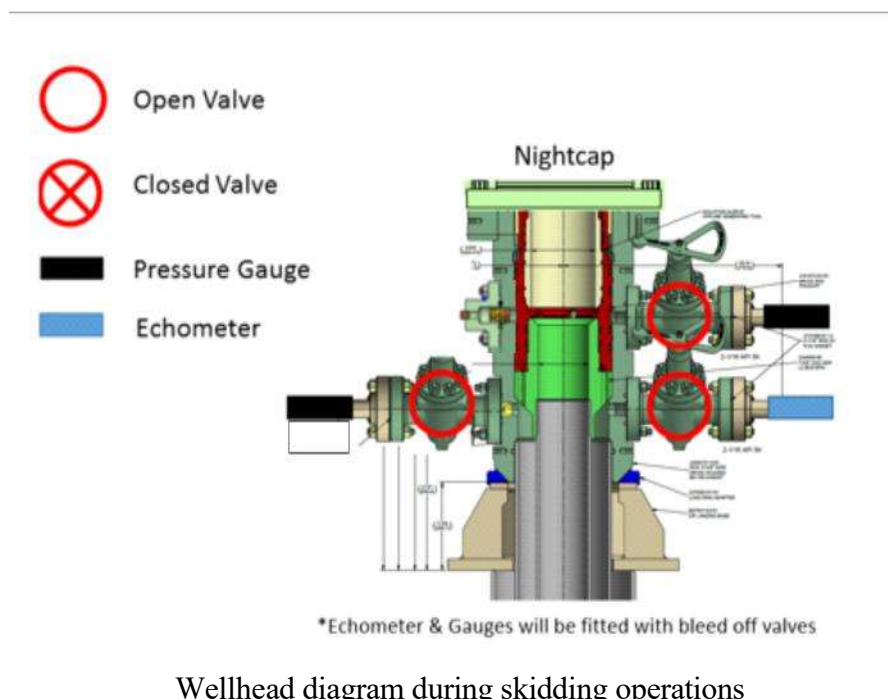

5. After confirmation of both annular barriers and internal barriers, nipple down BOP and install cap flange.
 - a. If any barrier fails to test, the BOP stack will not be nipped down until after the cement job is completed with cement 500ft above the highest formation capable of flow with kill weight mud above or after it has achieved 50 psi compressive strength if cannot be verified.
6. Skid rig to next well on pad.
7. Confirm well is static before removing cap flange, flange will not be removed and offline cementing operations will not commence until well is under control. If well is not static, casing outlet valves will provide access to both the casing ID and annulus. Rig or third party pump truck will kill well prior to cementing or nipping up for further remediation.
 - a. Well Control Plan
 - i. The Drillers Method will be the primary well control method to regain control of the wellbore prior to cementing, if wellbore conditions do not permit the drillers method other methods of well control may be used
 - ii. Rig pumps or a 3rd party pump will be tied into the upper casing valve to pump down the casing ID
 - iii. A high pressure return line will be rigged up to lower casing valve and run to choke manifold to control annular pressure
 - iv. Once influx is circulated out of the hole, kill weight mud will be circulated
 - v. Well will be confirmed static
 - vi. Once confirmed static, cap flange will be removed to allow for offline cementing operations to commence
8. Install offline cement tool
9. Rig up cement equipment

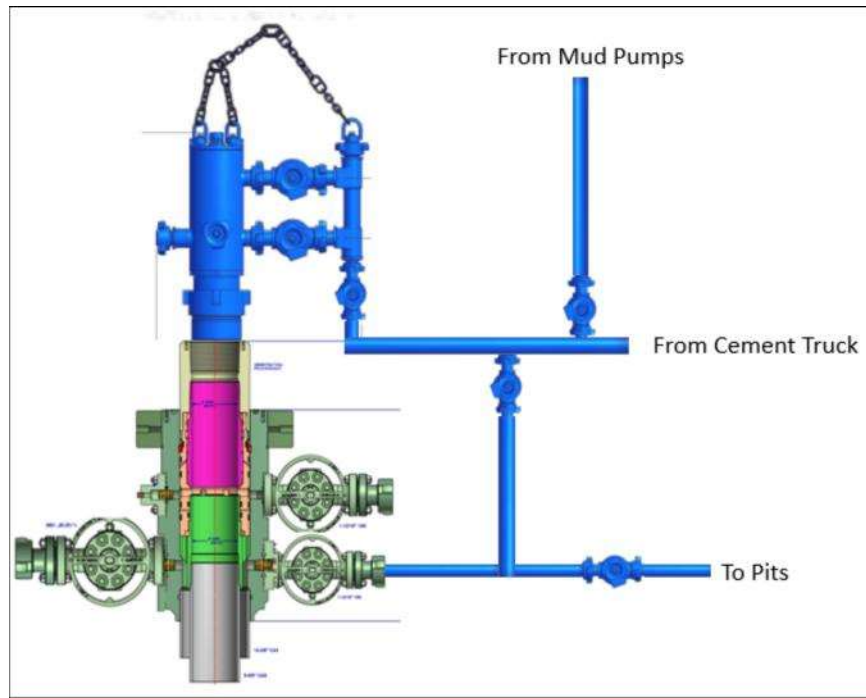

Wellhead diagram during offline cementing operations

10. Circulate bottoms up with cement truck
 - a. If gas is present on bottoms up, well will be shut in and returns rerouted through gas buster to handle entrained gas
 - b. Max anticipated time before circulating with cement truck is 6 hrs
11. Perform cement job taking returns from the annulus wellhead valve
12. Confirm well is static and floats are holding after cement job
13. Remove cement equipment, offline cement tools and install night cap with pressure gauge for monitoring.



OXY – OFFLINE PRODUCTION CEMENTING

SAFETY & EFFICIENCY

Oxy NM Team

12/22/25

LEAD WITH PASSION • OUTPERFORM EXPECTATIONS • DELIVER RESULTS RESPONSIBLY • UNLEASH OPPORTUNITIES • COMMIT TO GOOD

BACKGROUND

- Oxy has successfully pumped hundreds of offline intermediate jobs (both deep/salts) since 2018
 - Single stage, two stage, bradenheads
- Why not productions?
 - Typically set production casing on slips, no ability to cement offline
 - Recently swapped to mandrel/packoffs on production
- Historical success
 - TX group cemented over 120+ production sections offline without issues. No well control incidents. Same wellhead provider as NM.
- Big Rig Well control certification
 - 2 x OXY DSM IADC supervisor level well control training
 - 2 x Rig manager IADC supervisor level well control training
 - 2 x driller IADC Driller level well control training
 - 1 x Oxy Field Superintendent IADC supervisor level well control training

INITIAL OFFLINE CHECKLIST

- All items must be met, if not job will be performed online
 1. Offline production cement jobs must be at or above Wolfcamp formation
 2. Nothing out of the ordinary observed during drilling, tripping or casing running operations in the production hole section
 3. Casing must be landed out on hanger
 4. Oxy Company man with well control certification must be present to monitor returns
 5. Rig manager is responsible for walking rig to next well
 6. BOP will **NOT** be nipped down if
 1. Any barrier fails to test
 2. Any offset frac operations are observed within 1 mile and in the same producing interval
 7. Oxy will not drill out next well until cement operations are concluded on offline portion



PROCEDURE

- Run casing as per standard ops. Confirm well is candidate via checklist. Conduct negative pressure test while running casing and confirm integrity of the float equipment.
 - Float equipment has 2 x 15K valves
- Land production casing on mandrel hanger
 - If casing is unable to be landed with a mandrel hanger, casing will be cemented online.
 - If utilizing a fluted/ported mandrel hanger, ensure well is static on the annulus and inside the casing by filling the pipe with kill weight fluid, remove landing joint, and set annular packoff rated to 10,000 psi. Pressure test same to 10,000 psi
 - If utilizing a solid mandrel hanger, ensure well is static on the annulus and inside the casing by filling the pipe with kill weight fluid. Pressure test seals to 10,000 psi. Remove landing joint.
- Install back pressure valve in the casing for a 3rd casing barrier.
 - Back pressure valve rated to a minimum of 10,000 psi.
- With the well Secured; nipple down BOP and secure on hydraulic carrier or cradle and Skid/Walk rig to next well on pad.
 - If any of the barriers fail to test, the BOP stack will not be nipped down until after the cement job has concluded.
 - b. Oxy Company Man/Field supt. will oversee Cementing Operations while Rig Manager walks the rig and nipples up the BOP.
 - c. Oxy will not drill out of the subsequent well until after plug bump.

PROCEDURE CONT.

- Install 15M Gate Valve, with wellhead adapter.
 - This creates an additional barrier on the annulus and inside the casing.
 - Gate valve rated to a minimum of 15,000 psi.
- Test connection between wellhead adapter seals against hanger neck and ring gasket to 10,000 psi.
- Remove backpressure valve from the casing.
- Rig up cement head and cementing lines.
- Perform cement job.
- Procedure continued on next page.

PROCEDURE CONT.

- If an influx is noted during the Cement Job:
 - It is the Company Man and field Supt. responsibility to maintain well control. Driller/rig manager will divert to offline operations and assist.
 - The manifold will redirect flow to the rig's chokes.
 - Backpressure will be held on the well with the chokes to ensure well control is maintained through the remainder of the cement job while circulating out the influx.
 - If annular surface pressure approaches 90% tested pressure of the manifold or if circulating the influx out with the cementing pumps is not feasible, the well can be secured by closing the casing valves (10M).
 - Once cement is in place, we will close the casing valves and confirm the well is static and floats are holding.
 - If the floats fail, the gate valve (15M) or cement head (10M) can be closed to secure the well.
- Confirm well is static and floats are holding after cement job.
- Remove cement head.
- Install back pressure valve.
- Remove 15M Gate Valve and Wellhead Adapter.
- Install night cap with pressure gauge for monitoring.
- Test night cap to 10,000 psi

WELLHEAD SCHEMATIC

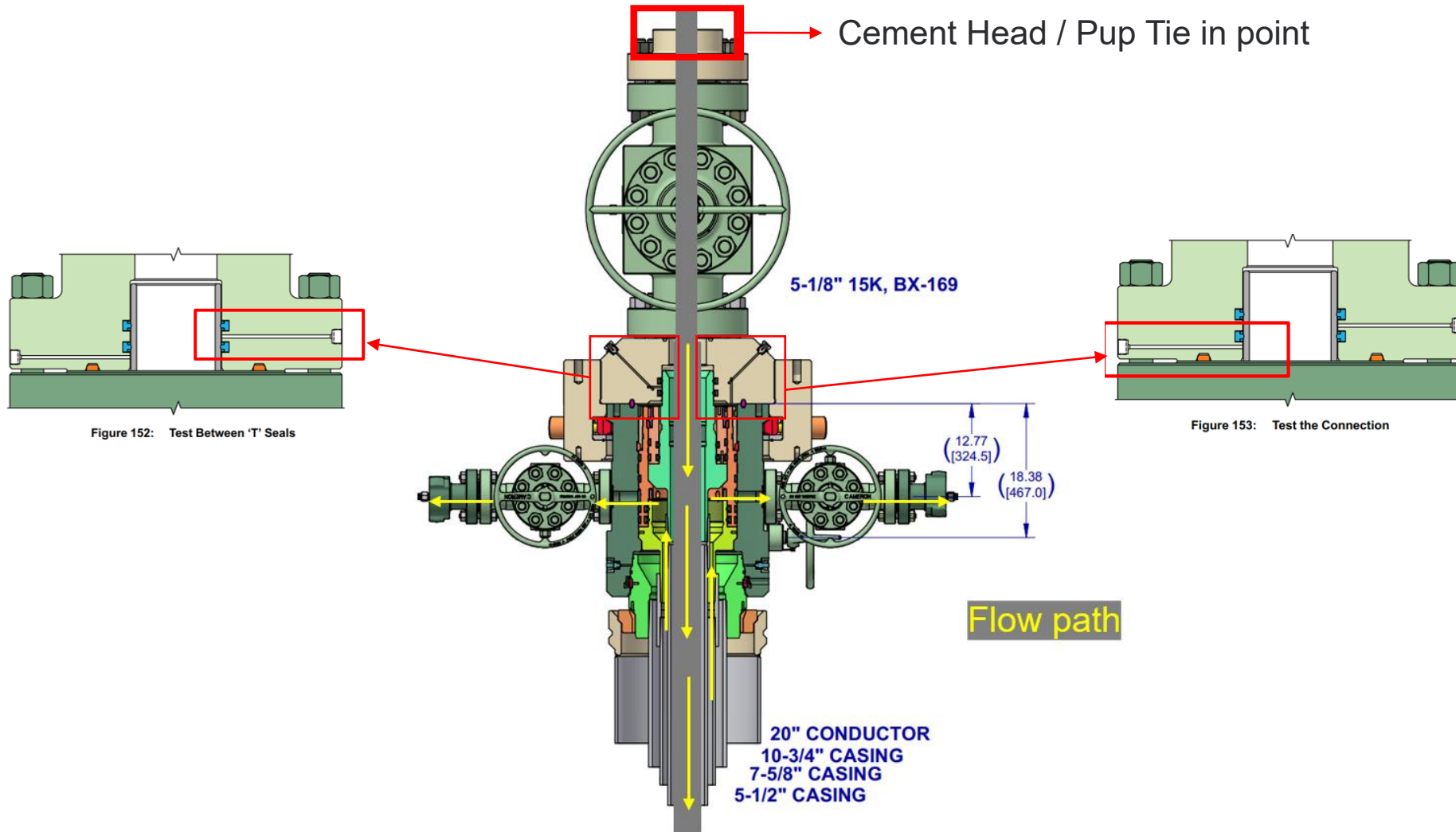

CASING BARRIERS – ONLINE VS OFFLINE

| Operation | Online | Offline |
|---|---|--|
| Install Cement Head | 1. Hydrostatic Barrier 2. Float Valves | 1. Hydrostatic Barrier 2. Float Valves 3. 15M Gate Valve |
| Cement Job | 1. Hydrostatic Barrier 2. Float Valves 3. Cement Head | 1. Hydrostatic Barrier 2. Float Valves 3. 15M Gate Valve 4. Cement Head |
| Remove Cement Head | 1. Float Valves | 1. Float Valves 2. 15M Gate Valve |
| Install BPV & Nipple down BOP/ Offline Adapter | 1. Float Valves 2. BPV | 1. Float Valves 2. BPV |
| Nipple up TA Cap | 1. Float Valves 2. BPV | 1. Float Valves 2. BPV |



BARRIERS

Barriers: During Removal of BOP

| Operation | Casing | Annulus |
|--------------------------|---|---|
| Nippling Down BOP | 1. BPV 2. Hydrostatic Barrier 3. Float Valves | 1. Hydrostatic Barrier 2. Mechanical 10M Packoff |

Barriers: During Offline Cementing of Production Casing

| Operation | Casing | Annulus |
|------------------------------|--|--|
| Pull BPV | 1. Hydrostatic Barrier 2. Float Valves 3. 15M Gate Valve | 1. Hydrostatic Barrier 2. Mechanical Packoff 3. 10M Wellhead Adapter |
| Install Cement Head | 1. Hydrostatic Barrier 2. Float Valves 3. 15M Gate Valve | 1. Hydrostatic Barrier 2. Mechanical 10M Packoff 3. 10M Wellhead Adapter |
| Cement Job | 1. Float Valves 2. 15M Gate Valve 3. Cement Head | 1. Hydrostatic Barrier 2. Mechanical 10M Packoff 3. 10M Wellhead Adapter |
| Remove Cement Head | 1. Float Valves 2. 15M Gate Valve | 1. Hydrostatic Barrier 2. Mechanical 10M Packoff 3. 10M Wellhead Adapter |
| Install BPV | 1. Float Valves 2. 15M Gate Valve | 1. Hydrostatic Barrier 2. Mechanical 10M Packoff 3. 10M Wellhead Adapter |
| Remove 10M Gate Valve | 1. Float Valves 2. BPV | 1. Hydrostatic Barrier 2. Mechanical 10M Packoff |
| Nipple up TA Cap | 1. Float Valves 2. BPV | 1. Hydrostatic Barrier 2. Mechanical 10M Packoff |



RIG UP: TRADITIONAL METHOD - ONLINE

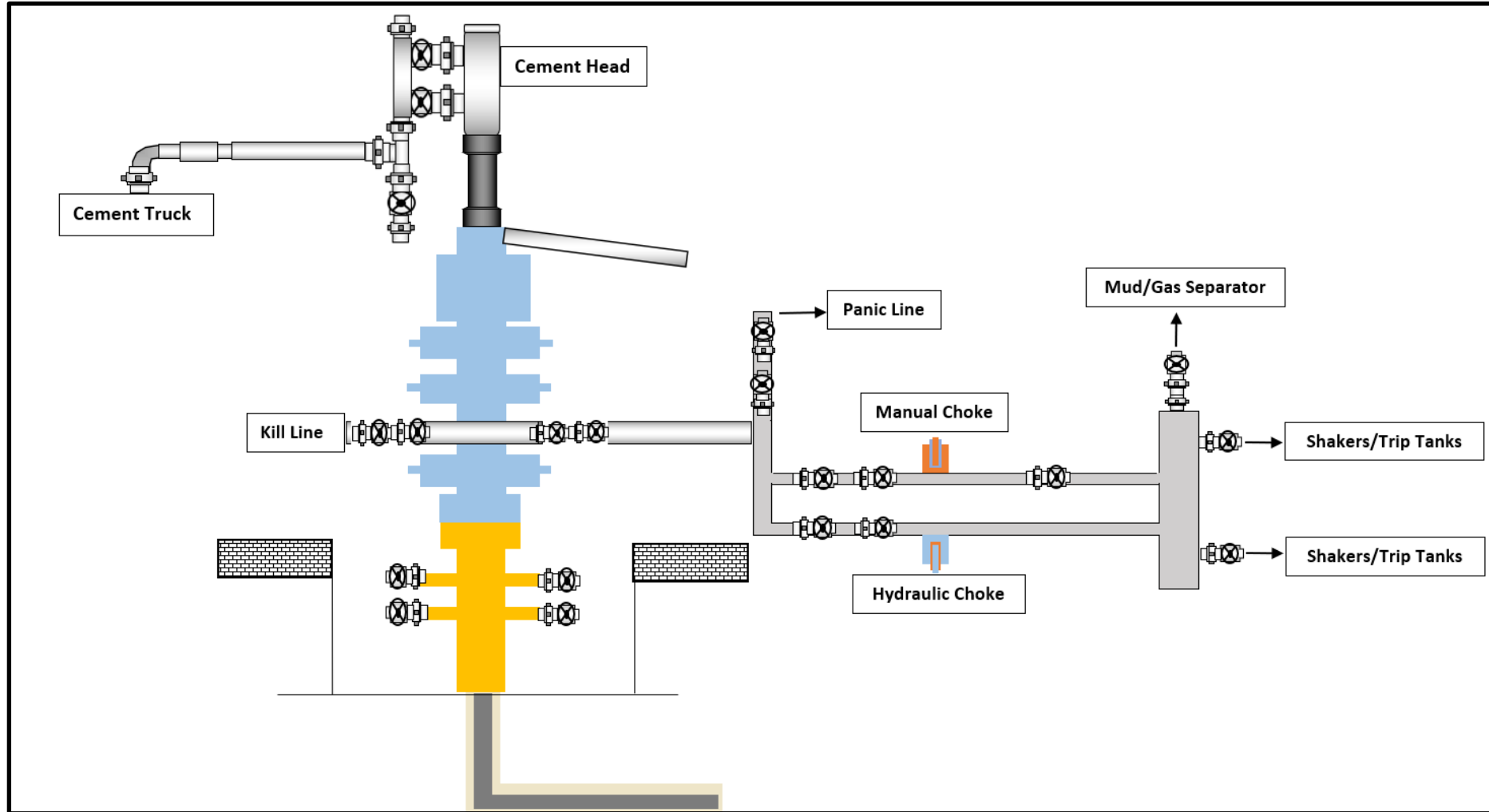

RIG UP: PROPOSED METHOD - OFFLINE

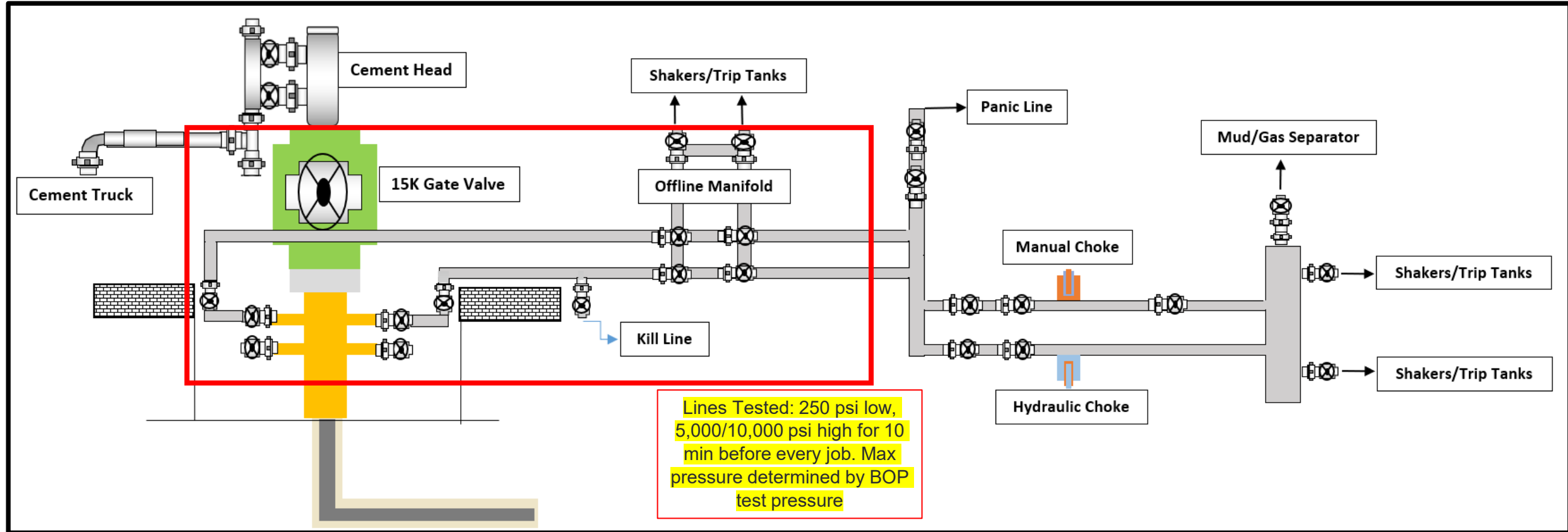

- Same well control capabilities as online
- Gate valve offers flexibility

OXY USA Inc
APD ATTACHMENT: SPUDDER RIG DATA

OPERATOR NAME / NUMBER: OXY USA Inc

1. SUMMARY OF REQUEST:

Oxy USA respectfully requests approval for the following operations for the surface hole in the drill plan:

1. Utilize a spudder rig to pre-set surface casing for time and cost savings.

2. Description of Operations

1. Spudder rig will move in to drill the surface hole and pre-set surface casing on the well.
 - a. After drilling the surface hole section, the spudder rig will run casing and cement following all of the applicable rules and regulations (43 CFR part 3170 Subpart 3172, all COAs and NMOCD regulations).
 - b. The spudder rig will utilize fresh water-based mud to drill the surface hole to TD. Solids control will be handled entirely on a closed loop basis. No earth pits will be used.
2. The wellhead will be installed and tested as soon as the surface casing is cut off and the WOC time has been reached.
3. A blind flange at the same pressure rating as the wellhead will be installed to seal the wellbore. Pressure will be monitored with needle valves installed on two wingvalves.
 - a. A means for intervention will be maintained while the drilling rig is not over the well.
4. Spudder rig operations are expected to take 2-3 days per well on the pad.
5. The BLM will be contacted and notified 24 hours prior to commencing spudder rig operations.
6. Drilling operations will begin with a larger rig and a BOP stack equal to or greater than the pressure rating that was permitted will be nipped up and tested on the wellhead before drilling operations resume on each well.
 - a. The larger rig will move back onto the location within 90 days from the point at which the wells are secured and the spudder rig is moved off location.
 - b. The BLM will be contacted / notified 24 hours before the larger rig moves back on the pre-set locations.
7. Oxy will have supervision on the rig to ensure compliance with all BLM and NMOCD regulations and to oversee operations.
8. Once the rig is removed, Oxy will secure the wellhead area by placing a guard rail around the cellar area.

Spudder Rig Layout

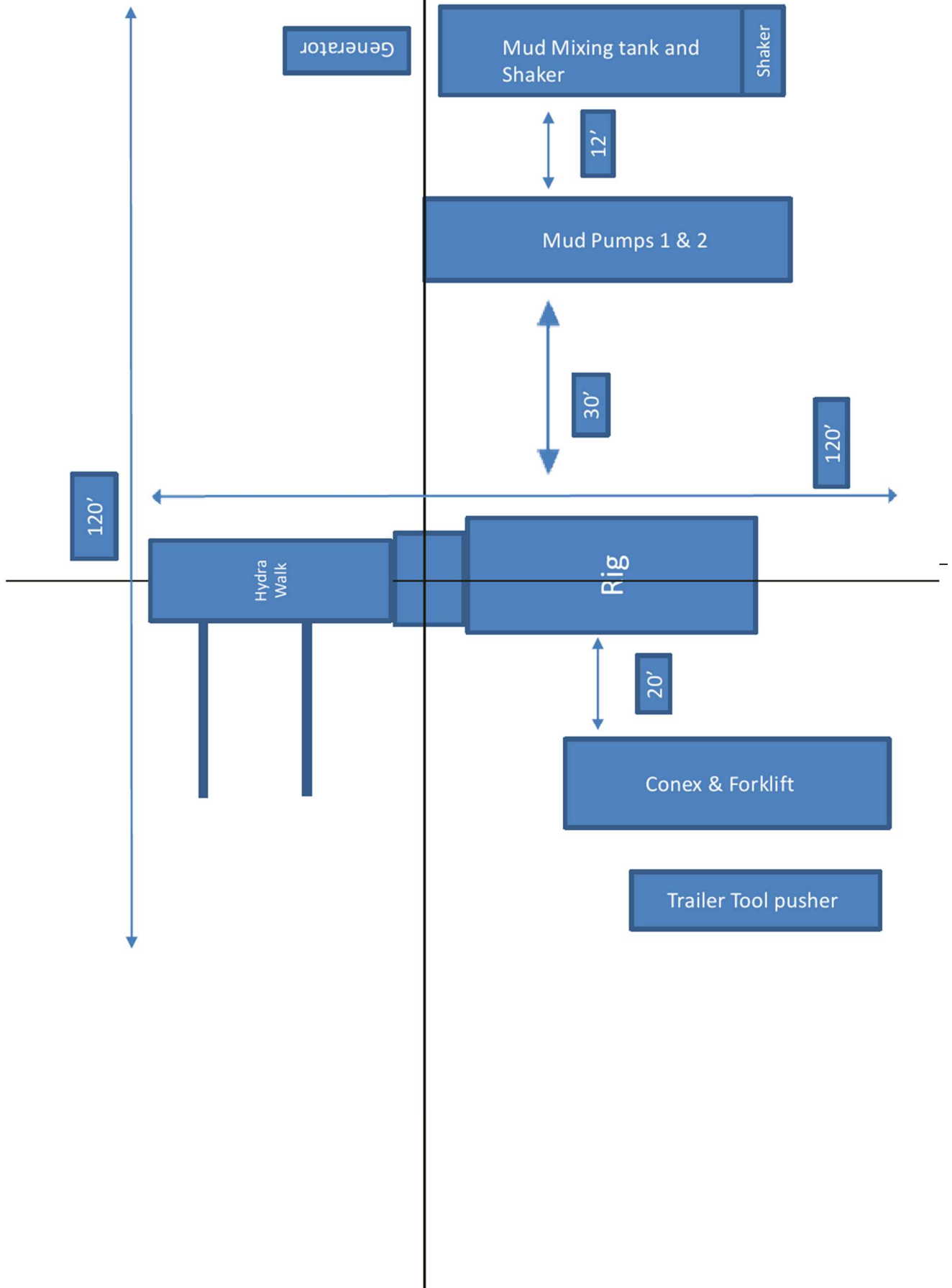

Oxy USA Inc. - TOP SPOT 12_13 FED 75H Drill Plan

1. Geologic Formations

| | | | |
|----------------------------|-------|------------------------------------|-----|
| TVD of Target (ft): | 12073 | Pilot Hole Depth (ft): | |
| Total Measured Depth (ft): | 22428 | Deepest Expected Fresh Water (ft): | 823 |

Delaware Basin

| Formation | MD-RKB (ft) | TVD-RKB (ft) | Expected Fluids |
|-----------------|-------------|--------------|-----------------|
| Rustler | 823 | 823 | |
| Salado | 1132 | 1132 | Salt |
| Marker Bed 126 | 2000 | 2000 | Salt |
| Castile | 2887 | 2887 | Salt |
| Delaware | 4453 | 4453 | Oil/Gas/Brine |
| Bell Canyon | 4514 | 4514 | Oil/Gas/Brine |
| Cherry Canyon | 5465 | 5465 | Oil/Gas/Brine |
| Brushy Canyon | 6595 | 6581 | Losses |
| Bone Spring | 8366 | 8325 | Oil/Gas |
| Bone Spring 1st | 9521 | 9463 | Oil/Gas |
| Bone Spring 2nd | 10119 | 10052 | Oil/Gas |
| Bone Spring 3rd | 11169 | 11086 | Oil/Gas |
| Wolfcamp | 11709 | 11617 | Oil/Gas |
| Penn | | | Oil/Gas |
| Strawn | | | Oil/Gas |

*H2S, water flows, loss of circulation, abnormal pressures, etc.

2. Casing Program

| Section | Hole Size (in) | MD | | TVD | | Csg. OD (in) | Csg Wt. (ppf) | Grade | Conn. |
|--------------|----------------|-----------|---------|-----------|---------|--------------|---------------|---------|--------------|
| | | From (ft) | To (ft) | From (ft) | To (ft) | | | | |
| Surface | 17.5 | 0 | 893 | 0 | 893 | 13.375 | 54.5 | J-55 | BTC |
| Salt | 12.25 | 0 | 4453 | 0 | 4453 | 10.75 | 40.5 | J-55 | BTC-SC |
| Intermediate | 9.875 | 0 | 11883 | 0 | 11777 | 7.625 | 26.4 | L-80 HC | BTC |
| Production | 6.75 | 0 | 22428 | 0 | 12073 | 5.5 | 20 | P-110 | Sprint-TC SC |

All casing strings will be tested in accordance with 43 CFR part 3170 Subpart 3172

| | | | |
|---|-----------------|------------------------|-------------------------|
| <i>All Casing SF Values will meet or exceed those below</i> | | | |
| SF Collapse | SF Burst | Body SF Tension | Joint SF Tension |
| 1.00 | 1.100 | 1.4 | 1.4 |

Annular Clearance Variance Request

As per the agreement reached in the Oxy/BLM face-to-face meeting on Feb 22, 2018, Oxy requests permission to allow deviation from the 0.422" annular clearance requirement. Please see Annular Clearance Variance attachment for further details.

| | Y or N |
|---|--------|
| Is casing new? If used, attach certification as required in 43 CFR 3160 | Y |
| Does casing meet API specifications? If no, attach casing specification sheet. | Y |
| Is premium or uncommon casing planned? If yes attach casing specification sheet. | Y |
| Does the above casing design meet or exceed BLM's minimum standards? If not provide justification (loading assumptions, casing design criteria). | Y |
| Will the intermediate pipe be kept at a minimum 1/3 fluid filled to avoid approaching the collapse pressure rating of the casing? | Y |
| Is well located within Capitan Reef? | |
| If yes, does production casing cement tie back a minimum of 50' above the Reef? | N |
| Is well within the designated 4 string boundary. | |
| Is well located in SOPA but not in R-111-Q? | |
| If yes, are the first 2 strings cemented to surface and 3 rd string cement tied back 500' into previous casing? | N |
| Is well located in R-111-Q and SOPA? | |
| If yes, are the first three strings cemented to surface? | Y |
| Is 2 nd string set 100' to 600' below the base of salt? | Y |
| Is well located in high Cave/Karst? | |
| If yes, are there two strings cemented to surface? | N |
| (For 2 string wells) If yes, is there a contingency casing if lost circulation occurs? | |
| Is well located in critical Cave/Karst? | |
| If yes, are there three strings cemented to surface? | N |

3. Cementing Program

| Section | Stage | Slurry: | Sacks | Yield (ft ³ /ft) | Density (lb/gal) | Excess: | TOC | Placement | Description |
|---------|-------|---------------------------|-------|-----------------------------|------------------|---------|--------|----------------------|-----------------------|
| Surface | 1 | Surface - Tail | 933 | 1.33 | 14.8 | 100% | - | Circulate | Class C+Accel. |
| Int.1 | 1 | Intermediate - Tail | 85 | 1.33 | 14.8 | 20% | 3,953 | Circulate | Class C+Accel. |
| Int.1 | 1 | Intermediate - Lead | 622 | 1.73 | 12.9 | 50% | - | Circulate | Class Pozz+Ret. |
| Int. 2 | 1 | Intermediate 1S - Tail | 676 | 1.68 | 13.2 | 5% | 6,845 | Circulate | Class C+Ret., Disper. |
| Int. 2 | 2 | Intermediate 2S - Tail BH | 444 | 1.71 | 13.3 | 25% | 3,953 | Bradenhead Post-Frac | Class C+Accel. |
| Prod. | 1 | Production - Tail | 625 | 1.84 | 13.3 | 25% | 11,383 | Circulate | Class C+Ret. |

Offline Cementing Request

Oxy requests a variance to cement the 9.625" and/or 7.625" intermediate casing strings offline in accordance to the approved variance, EC Tran 461365. Please see Offline Cementing Variance attachment for further details.

Bradenhead CBL Request

Oxy requests permission to adjust the CBL requirement after bradenhead cement jobs, on 7-5/8" intermediate casings, as per the agreement reached in the OXY/BLM meeting on September 5, 2019. Please see Bradenhead CBL Variance attachment for further details.

4. Pressure Control Equipment

| BOP installed and tested before drilling which hole? | Size? | Min. Required WP | Type | ✓ | Tested to: | TVD Depth (ft) per Section: |
|--|---------|------------------|------------|---|--------------------------|-----------------------------|
| 12.25" Hole | 13-5/8" | 5M | Annular | ✓ | 70% of working pressure | 4453 |
| | | 5M | Blind Ram | ✓ | 250 psi / 5000 psi | |
| | | | Pipe Ram | | | |
| | | | Double Ram | ✓ | | |
| | | | Other* | | | |
| 9.875" Hole | 13-5/8" | 5M | Annular | ✓ | 70% of working pressure | 11777 |
| | | 5M | Blind Ram | ✓ | 250 psi / 5000 psi | |
| | | | Pipe Ram | | | |
| | | | Double Ram | ✓ | | |
| | | | Other* | | | |
| 6.75" Hole | 13-5/8" | 5M | Annular | ✓ | 100% of working pressure | 12073 |
| | | 10M | Blind Ram | ✓ | 250 psi / 10000 psi | |
| | | | Pipe Ram | | | |
| | | | Double Ram | ✓ | | |
| | | | Other* | | | |

*Specify if additional ram is utilized

BOP/BOPE will be tested by an independent service company to 250 psi low and the high pressure indicated above per 43 CFR part 3170 Subpart 3172 requirements. The System may be upgraded to a higher pressure but still tested to the working pressure listed in the table above. If the system is upgraded all the components installed will be functional and tested.

Pipe rams will be operationally checked each 24 hour period. Blind rams will be operationally checked on each trip out of the hole. These checks will be noted on the daily tour sheets. Other accessories to the BOP equipment will include a Kelly cock and floor safety valve (inside BOP) and choke lines and choke manifold.

5M Annular BOP Request

Per BLM's Memorandum No. NM-2017-008: *Decision and Rationale for a Variance Allowing the Use of a 5M Annular Preventer with a 10M BOP Stack*, Oxy requests to employ a 5M annular with a 10M BOPE stack in the pilot and lateral sections of the well and will ensure that two barriers to flow are maintained at all times. Please see Annular BOP Variance attachment for further details.

| | |
|---|--|
| | <p>Formation integrity test will be performed per 43 CFR part 3170 Subpart 3172. On Exploratory wells or on that portion of any well approved for a 5M BOPE system or greater, a pressure integrity test of each casing shoe shall be performed. Will be tested in accordance with 43 CFR part 3170 Subpart 3172.</p> |
| | <p>A variance is requested for the use of a flexible choke line from the BOP to Choke Manifold. See attached for specs and hydrostatic test chart.</p> |
| Y | <p>Are anchors required by manufacturer?</p> |
| | <p>A multibowl or a unionized multibowl wellhead system will be employed. The wellhead and connection to the BOPE will meet all API 6A requirements. The BOP will be tested per 43 CFR part 3170 Subpart 3172 after installation on the surface casing which will cover testing requirements for a maximum of 30 days. If any seal subject to test pressure is broken the system must be tested. We will test the flange connection of the wellhead with a test port that is directly in the flange. We are proposing that we will run the wellhead through the rotary prior to cementing surface casing as discussed with the BLM on October 8, 2015.</p> <p>See attached schematics.</p> |

BOP Break Testing Request

Oxy requests permission to adjust the BOP break testing (intermediate and production) requirements as per the agreement reached with OXY/BLM in January 2026. Please see BOP Break Testing Variance attachment for further details.

Oxy will use Cameron ADAPT wellhead system that uses an OEC top flange connection. This connection has been fully vetted and verified by API to Spec 6A and carries an API monogram.

5. Mud Program

| Section | Depth | | Depth - TVD | | Type | Weight (ppg) | Viscosity | Water Loss |
|----------------|-----------|---------|-------------|---------|--|--------------|-----------|------------|
| | From (ft) | To (ft) | From (ft) | To (ft) | | | | |
| Surface | 0 | 893 | 0 | 893 | Water-Based Mud | 8.6 - 8.8 | 40-60 | N/C |
| Intermediate 1 | 893 | 4453 | 893 | 4453 | Saturated Brine-Based or Oil-Based Mud | 8.0 - 10.0 | 35-45 | N/C |
| Intermediate 2 | 4453 | 11883 | 4453 | 11777 | Water-Based or Oil-Based Mud | 8.0 - 10.0 | 38-50 | N/C |
| Production | 11883 | 22428 | 11777 | 12073 | Water-Based or Oil-Based Mud | 9.5 - 13 | 38-50 | N/C |

Sufficient mud materials to maintain mud properties and meet minimum lost circulation and weight increase requirements will be kept on location at all times. The following is a general list of products: Barite, Bentonite, Gypsum, Lime, Soda Ash, Caustic Soda, Nut Plug, Cedar Fiber, Cotton Seed Hulls, Drilling Paper, Salt Water Clay, ACL2. Oxy will use a closed mud system.

| | |
|---|--------------------------------|
| What will be used to monitor the loss or gain of fluid? | PVT/MD Totco/Visual Monitoring |
|---|--------------------------------|

6. Logging and Testing Procedures

| Logging, Coring and Testing. | |
|------------------------------|--|
| Yes | Will run GR from TD to surface (horizontal well – vertical portion of hole). Stated logs run will be in the Completion Report and submitted to the BLM. |
| No | Logs are planned based on well control or offset log information. |
| No | Drill stem test? If yes, explain |
| No | Coring? If yes, explain |
| Additional logs planned | Interval |
| No | Resistivity |
| No | Density |
| Yes | CBL Production string |
| Yes | Mud log Bone Spring – TD |
| No | PEX |

7. Drilling Conditions

| Condition | Specify what type and where? |
|-------------------------------|------------------------------|
| BH Pressure at deepest TVD | 8162 psi |
| Abnormal Temperature | No |
| BH Temperature at deepest TVD | 177°F |

Pump high viscosity sweeps as needed for hole cleaning. The mud system will be monitored visually/manually as well as with an electronic PVT. The necessary mud products for additional weight and fluid loss control will be on location at all times. Appropriately weighted mud will be used to isolate potential gas, oil, and water zones until such time as casing can be cemented into place for zonal

| | |
|---|-------------------|
| Hydrogen Sulfide (H2S) monitors will be installed prior to drilling out the surface shoe. If H2S is detected in concentrations greater than 100 ppm, the operator will comply with the provisions of 43 CFR part 3170 Subpart 3172. If Hydrogen Sulfide is encountered, measured values and formations will be provided to the BLM. | |
| N | H2S is present |
| Y | H2S Plan attached |

8. Other facets of operation

| | Yes/No |
|---|--------|
| Will the well be drilled with a walking/skidding operation? If yes, describe. We plan to drill the 4 well pad in batch by section: all surface sections, intermediate sections and production sections. The wellhead will be secured with a night cap whenever the rig is not over the well. | Yes |
| Will more than one drilling rig be used for drilling operations? If yes, describe. Oxy requests the option to contract a Surface Rig to drill, set surface casing, and cement for this well. If the timing between rigs is such that Oxy would not be able to preset surface, the Primary Rig will MIRU and drill the well in its entirety per the APD. Please see the attached document for information on the spudder rig. | Yes |

Total Estimated Cuttings Volume: 1956 bbls

| | | | |
|-------------------------------------|--------------------|-----------------------------|---|
| Property Name TOP SPOT 12_13 FED | Well Number 75H | Drawn By L.M.W. 11-01-22 | Revised By REV. 6 T.I.R. 09-22-25 (SHL & WELLBORE CHANGES) |
|-------------------------------------|--------------------|-----------------------------|---|

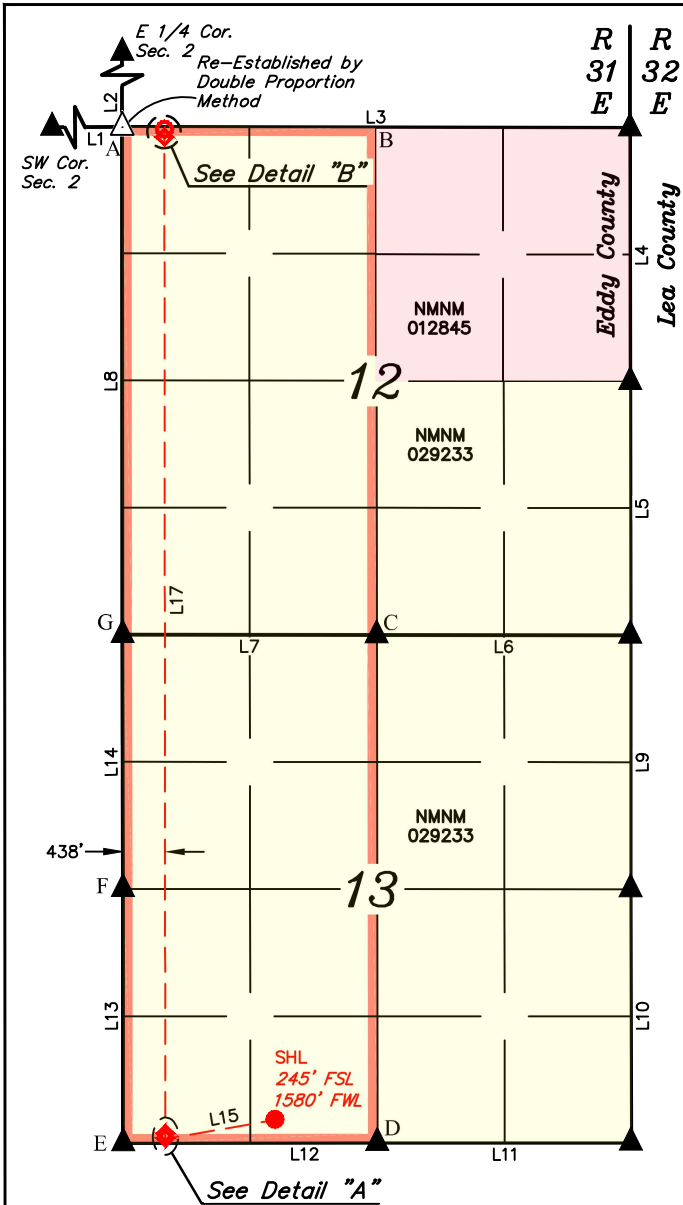

- = SURFACE HOLE LOCATION
- ◆ = KICK OFF POINT/FIRST TAKE POINT/LAST TAKE POINT
- ◇ = LEASE CROSSING
- = BOTTOM HOLE LOCATION
- ▲ = SECTION CORNER LOCATED
- △ = SECTION CORNER RE-ESTABLISHED. (Not Set on Ground.)
- = HORIZONTAL SPACING UNIT

| POINT | HSU COORDINATES | | HSU COORDINATES | |
|-------|------------------------------------|------------------------------------|------------------------------------|------------------------------------|
| | NAD 27 N.M. STATE PLANE, EAST ZONE | NAD 83 N.M. STATE PLANE, EAST ZONE | NAD 27 N.M. STATE PLANE, EAST ZONE | NAD 83 N.M. STATE PLANE, EAST ZONE |
| A | 514540.77' | 683235.75' | 514601.46' | 724417.79' |
| B | 514547.09' | 685877.72' | 514607.78' | 727059.77' |
| C | 509266.21' | 685905.18' | 509326.77' | 727087.38' |
| D | 503984.61' | 685934.52' | 504045.03' | 727116.88' |
| E | 503967.67' | 683289.55' | 504028.09' | 724471.90' |
| F | 506616.70' | 683277.81' | 506677.18' | 724460.08' |
| G | 509257.35' | 683262.39' | 509317.91' | 724444.58' |

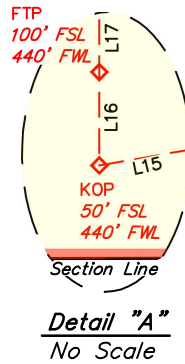
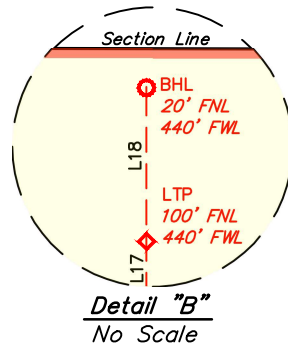

| LINE TABLE | | |
|------------|-------------|-----------|
| LINE | DIRECTION | LENGTH |
| L1 | S89°48'38"W | 5283.00' |
| L2 | N00°05'15"W | 2642.31' |
| L3 | N89°53'45"W | 5284.97' |
| L4 | N00°02'49"W | 2638.99' |
| L5 | N00°04'00"W | 2641.40' |
| L6 | N89°55'57"W | 2642.34' |
| L7 | N89°57'03"W | 2643.31' |
| L8 | N00°02'58"W | 5284.61' |
| L9 | N00°03'46"W | 2640.91' |
| L10 | N00°04'43"W | 2638.22' |
| L11 | S89°59'17"W | 2641.57' |
| L12 | S89°52'27"W | 2645.53' |
| L13 | N00°00'53"W | 2649.62' |
| L14 | N00°05'42"W | 2641.26' |
| L15 | S80°11'05"W | 1156.90' |
| L16 | N00°00'53"W | 50.00' |
| L17 | N00°03'09"W | 10373.72' |
| L18 | N00°02'58"W | 80.00' |

- NOTE:**
- Distances referenced on plat to section lines are perpendicular.
 - Basis of Bearings is a Transverse Mercator Projection with a Central Meridian of W103°53'00" (NAD 83)
 - Colored areas within section lines represent Federal oil & gas leases.

| | |
|---|--|
| NAD 83 (SURFACE HOLE LOCATION) | |
| LATITUDE = 32°23'05.72" (32.384922°) | |
| LONGITUDE = -103°44'05.83" (-103.734953°) | |
| NAD 27 (SURFACE HOLE LOCATION) | |
| LATITUDE = 32°23'05.28" (32.384800°) | |
| LONGITUDE = -103°44'04.07" (-103.734464°) | |
| STATE PLANE NAD 83 (N.M. EAST) | |
| N: 504282.87' E: 726050.49' | |
| STATE PLANE NAD 27 (N.M. EAST) | |
| N: 504222.45' E: 684868.15' | |

| | |
|---|--|
| NAD 83 (KICK OFF POINT) | |
| LATITUDE = 32°23'03.78" (32.384385°) | |
| LONGITUDE = -103°44'19.13" (-103.738646°) | |
| NAD 27 (KICK OFF POINT) | |
| LATITUDE = 32°23'03.34" (32.384262°) | |
| LONGITUDE = -103°44'17.37" (-103.738157°) | |
| STATE PLANE NAD 83 (N.M. EAST) | |
| N: 504080.90' E: 724911.58' | |
| STATE PLANE NAD 27 (N.M. EAST) | |
| N: 504020.48' E: 683729.24' | |

| | |
|---|--|
| NAD 83 (FIRST TAKE POINT) | |
| LATITUDE = 32°23'04.28" (32.384522°) | |
| LONGITUDE = -103°44'19.13" (-103.738646°) | |
| NAD 27 (FIRST TAKE POINT) | |
| LATITUDE = 32°23'03.84" (32.384399°) | |
| LONGITUDE = -103°44'17.37" (-103.738157°) | |
| STATE PLANE NAD 83 (N.M. EAST) | |
| N: 504130.89' E: 724911.36' | |
| STATE PLANE NAD 27 (N.M. EAST) | |
| N: 504070.47' E: 683729.02' | |

| | |
|---|--|
| NAD 83 (LAST TAKE POINT) | |
| LATITUDE = 32°24'46.91" (32.413031°) | |
| LONGITUDE = -103°44'19.07" (-103.738631°) | |
| NAD 27 (LAST TAKE POINT) | |
| LATITUDE = 32°24'46.47" (32.412909°) | |
| LONGITUDE = -103°44'17.31" (-103.738141°) | |
| STATE PLANE NAD 83 (N.M. EAST) | |
| N: 514502.53' E: 724858.21' | |
| STATE PLANE NAD 27 (N.M. EAST) | |
| N: 514441.84' E: 683676.17' | |

| | |
|---|--|
| NAD 83 (BOTTOM HOLE LOCATION) | |
| LATITUDE = 32°24'47.70" (32.413251°) | |
| LONGITUDE = -103°44'19.07" (-103.738631°) | |
| NAD 27 (BOTTOM HOLE LOCATION) | |
| LATITUDE = 32°24'47.26" (32.413129°) | |
| LONGITUDE = -103°44'17.31" (-103.738141°) | |
| STATE PLANE NAD 83 (N.M. EAST) | |
| N: 514582.52' E: 724857.81' | |
| STATE PLANE NAD 27 (N.M. EAST) | |
| N: 514521.82' E: 683675.77' | |

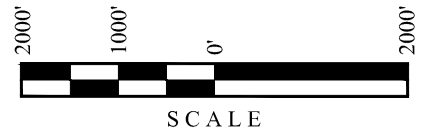

OXY APD CHANGE SUNDRY LIST FORM

| | |
|-------------------------------|----------------------------|
| DATE SUNDRY WORKSHEET CREATED | 2/18/2026 |
| WELL NAME_NUMBER | TOP SPOT 12_13 FEDERAL 75H |
| API NUMBER | PENDING |
| ESTIMATED SPUD DATE | 4/2/2026 |

| ITEM | APD BASE LINE (For Regulatory to Complete) | | | | | | | | | | SUNDRY PLAN (Groups to complete the latest plan) | | | | | | | | | |
|-------------------------|--|----------------------------|----------------|-------|----------------|------------------|---------|----------------------|------------------|---------------|--|----------------------------|-------|----------------|------------------|--------------|----------------------|------------------|---------------|---|
| | Date APD/BASE LINE APPROVED: 01/22/26 | | | | | | | | | | DATE Sundry Worksheet : 02/18/26 | | | | | | | | | |
| NAME | TOP SPOT 12_13 FEDERAL 75H | | | | | | | | | | TOP SPOT 12_13 FEDERAL 75H | | | | | | | | | |
| NSL | NO | | | | | | | | | | NO | | | | | | | | | |
| SHL | 245 FSL 1580 FWL | | | | | | | | | | 245 FSL 1580 FWL | | | | | | | | | |
| PAD | LSTTNK 1303 | | | | | | | | | | LSTTNK 1303 | | | | | | | | | |
| BHL | 20 FNL 440 FWL | | | | | | | | | | 20 FNL 440 FWL | | | | | | | | | |
| H2U SIZE, ACRES | 640 | | | | | | | | | | 640 | | | | | | | | | |
| POOL | WC 22531E13 | | | | | | | | | | WC 22531E13 | | | | | | | | | |
| TVD | 12073 | | | | | | | | | | 12073 | | | | | | | | | |
| TARGET FORMATION | WOLFCAMP | | | | | | | | | | WOLFCAMP | | | | | | | | | |
| Surface Planning | APD BASE LINE | | | | | | | | | | SUNDRY PLAN | | | | | | | | | |
| | Section | Hole Size (in.) | MD | TVD | Csg OD (in) | Csg WT | Grade | Conn. | | | Section | Hole Size (in.) | MD | TVD | Csg OD (in) | Csg WT (ppf) | Grade | Conn. | | |
| | Surface | 17.5 | 893 | 893 | 13.375 | 54.5 | J-55 | BTC | | | Surface | 17.5 | 893 | 893 | 13.375 | 54.5 | J-55 | BTC | | |
| | Salt | 12.25 | 4453 | 4453 | 10.75 | 40.5 | J-55 | BTC-SC | | | Int | 12.25 | 4453 | 4453 | 10.75 | 40.5 | J-55 | BTC-SC | | |
| | Int | 9.875 | 11480 | 11390 | 7.625 | 26.4 | L-80 HC | BTC | | | Int2 | 9.875 | 11883 | 11777 | 7.625 | 26.4 | L-80 HC | BTC | | |
| | Prod | 6.75 | 22428 | 12073 | 5.5 | 20 | P-110 | SPRINT-TC SC | | | Prod | 6.75 | 22428 | 12073 | 5.5 | 20 | P-110 | SPRINT-TC SC | | |
| | Liner | | | | | | | | | | Liner | | | | | | | | | |
| | Drilling | APD BASE LINE | | | | | | | | | | SUNDRY PLAN | | | | | | | | |
| | | Section/Stage | Slurry | Sacks | Yield (ft³/ft) | Density (lb/gal) | Excess | TOC | Placement | Description | Section/Stage | Slurry | Sacks | Yield (ft³/ft) | Density (lb/gal) | Excess | TOC | Placement | Description | |
| | | Surf | SURFACE - TAIL | 933 | 1.33 | 14.8 | 100% | | CIRCULATE | CLASS C+ACCEL | Surf | SURFACE - TAIL | 933 | 1.33 | 14.8 | 100% | | CIRCULATE | CLASS C+ACCEL | |
| Int/1 | | INTERM - TAIL | 85 | 1.33 | 14.8 | 20% | 3953 | CIRCULATE | CLASS C+ACCEL | Int/1 | INTERM - TAIL | 85 | 1.33 | 14.8 | 20% | 3953 | CIRCULATE | CLASS C+ACCEL | | |
| Int/1 | | INTERM - LEAD | 622 | 1.73 | 12.9 | 50% | | CIRCULATE | CLASS POZZ+RET | Int/1 | INTERM - LEAD | 622 | 1.73 | 12.9 | 50% | | CIRCULATE | CLASS POZZ+RET | | |
| Int2 | | INTERM IS - TAIL | 622 | 1.68 | 13.2 | 5% | 6845 | CIRCULATE | CLASS C+RET,DISP | Int2 | INTERM IS - TAIL | 676 | 1.68 | 13.2 | 5% | 6845 | CIRCULATE | CLASS C+RET,DISP | | |
| Int2 | | INTERM 25 - TAIL BH | 444 | 1.71 | 13.3 | 25% | 3953 | BRADENHEAD POST-FRAC | CLASS C+ACCEL | Int2 | INTERM 25 - TAIL BH | 444 | 1.71 | 13.3 | 25% | 3953 | BRADENHEAD POST-FRAC | CLASS C+ACCEL | | |
| Prod | | PROD - TAIL | 648 | 1.84 | 13.3 | 25% | 10980 | CIRCULATE | CLASS C+RET | Prod | PROD - TAIL | 625 | 1.84 | 13.3 | 25% | 11383 | CIRCULATE | CLASS C+RET | | |
| VARIANCES | | APD BASE LINE | | | | | | | | | | SUNDRY PLAN | | | | | | | | |
| | | BOP Break Testing Variance | | | | | | | | | X | BOP Break Testing Variance | | | | | | | | |
| | SM Annular BOP Variance | | | | | | | | | X | SM Annular BOP Variance | | | | | | | | | X |
| | Bradenhead CBL Variance | | | | | | | | | X | Bradenhead CBL Variance | | | | | | | | | X |
| | Offline Cementing Variance | | | | | | | | | X | Offline Cementing Variance | | | | | | | | | X |
| | Production Annular Clearance Variance | | | | | | | | | X | Production Annular Clearance Variance | | | | | | | | | X |
| | Flexible Choke Line Variance | | | | | | | | | X | Flexible Choke Line Variance | | | | | | | | | X |
| (Pilot Hole, Logs etc.) | | | | | | | | | | | | (Pilot Hole, Logs etc.) | | | | | | | | |

Sante Fe Main Office
Phone: (505) 476-3441

General Information
Phone: (505) 629-6116

Online Phone Directory
<https://www.emnrd.nm.gov/ocd/contact-us>

State of New Mexico
Energy, Minerals and Natural Resources
Oil Conservation Division
1220 S. St Francis Dr.
Santa Fe, NM 87505

CONDITIONS

Action 567118

CONDITIONS

| | |
|--|---|
| Operator: OXY USA INC P.O. Box 4294 Houston, TX 772104294 | OGRID: 16696 |
| | Action Number: 567118 |
| | Action Type: [C-103A] NOI Change of Plans (C-103A) |

CONDITIONS

| Created By | Condition | Condition Date |
|-------------|--|----------------|
| ward.rikala | Cement is required to circulate on both surface and intermediate1 strings of casing. | 4/17/2026 |
| ward.rikala | Post Bradenhead cement squeeze, a CBL will be required. If zonal isolation was not achieved per OCD requirements, then remedial work is required before operations can continue. | 4/17/2026 |
| ward.rikala | Any previous COA's not addressed within the updated COA's still apply. | 4/17/2026 |