

Phone: (505) 476-3441
General Information
Phone: (505) 629-6116

State of New Mexico
Energy, Minerals and Natural Resources

Form C-103
Revised July 18, 2013

Online Phone Directory Visit:
<https://www.emnrd.nm.gov/ocd/contact-us/>

OIL CONSERVATION DIVISION
1220 South St. Francis Dr.
Santa Fe, NM 87505

WELL API NO. 30-025-55821
5. Indicate Type of Lease FED STATE <input type="checkbox"/> FEE <input type="checkbox"/>
6. State Oil & Gas Lease No. NMNM087274
7. Lease Name or Unit Agreement Name TOPAZ FEDERAL COM
8. Well Number 301H
9. OGRID Number 260297
10. Pool name or Wildcat WC-025 G-08 S213304D/BONE SPRING
11. Elevation (Show whether DR, RKB, RT, GR, etc.) 3692'

SUNDRY NOTICES AND REPORTS ON WELLS
(DO NOT USE THIS FORM FOR PROPOSALS TO DRILL OR TO DEEPEN OR PLUG BACK TO A DIFFERENT RESERVOIR. USE "APPLICATION FOR PERMIT" (FORM C-101) FOR SUCH PROPOSALS.)

1. Type of Well: Oil Well Gas Well Other

2. Name of Operator
BTA OIL PRODUCERS, LLC

3. Address of Operator
104 S Pecos Midland, TX 79701

4. Well Location
Unit Letter D : 551 feet from the N line and 1223 feet from the W line
Section 31 Township 20S Range 34E NMPM County LEA

12. Check Appropriate Box to Indicate Nature of Notice, Report or Other Data

NOTICE OF INTENTION TO:		SUBSEQUENT REPORT OF:	
PERFORM REMEDIAL WORK <input type="checkbox"/>	PLUG AND ABANDON <input type="checkbox"/>	REMEDIAL WORK <input type="checkbox"/>	ALTERING CASING <input type="checkbox"/>
TEMPORARILY ABANDON <input type="checkbox"/>	CHANGE PLANS <input checked="" type="checkbox"/>	COMMENCE DRILLING OPNS. <input type="checkbox"/>	P AND A <input type="checkbox"/>
PULL OR ALTER CASING <input type="checkbox"/>	MULTIPLE COMPL <input type="checkbox"/>	CASING/CEMENT JOB <input type="checkbox"/>	
DOWNHOLE COMMINGLE <input type="checkbox"/>			
CLOSED-LOOP SYSTEM <input type="checkbox"/>			
OTHER: <input type="checkbox"/>		OTHER: <input type="checkbox"/>	

13. Describe proposed or completed operations. (Clearly state all pertinent details, and give pertinent dates, including estimated date of starting any proposed work). SEE RULE 19.15.7.14 NMAC. For Multiple Completions: Attach wellbore diagram of proposed completion or recompletion.

BTA Oil Producers LLC respectfully requests the following footage, casing, cement, drill plan, assigned acreage and name changes to the original APD as approved. We are also requesting a variance for BOP break testing. Please see attached documents for more details.

APD ID 10400081220
From: TOPAZ FEDERAL COM 301H
To: TOPAZ 21602 30 FED COM 3H
From: 640.56 acres
To: 320.56 acres
Please see New Footages on attached pdf

Spud Date: **9/30/2025**

Rig Release Date: **10/29/2025**

I hereby certify that the information above is true and complete to the best of my knowledge and belief.

SIGNATURE Liz Velasco TITLE Regulatory Analyst DATE 3/23/2026

Type or print name Liz Velasco E-mail address: lvelasco@btaoil.com PHONE: 432-682-3753

For State Use Only

APPROVED BY: _____ TITLE _____ DATE _____
Conditions of Approval (if any): _____

TOPAZ 21602 30 FED COM 3H

Old Name	Old Footages	SHL		KOP		FTP		DP1 -TURN POINT 1		NPZ1-OFFSET 1		Apex-MTP		NPZ2-OFFSET 2		DP2-TURN POINT 2		LTP		BHL	
TOPAZ FED COM 301H		Sec 31 20S 34E		Sec 30 20S 34E		Sec 30 20S 34E		Sec 30 20S 34E		Sec 30 20S 34E		Sec 30 20S 34E		Sec 30 20S 34E		Sec 30 20S 34E		Sec 30 20S 34E		Sec 30 20S 34E	
		558 FNL	1252 FWL	100 FSL	1980 FWL	100 FSL	1980 FWL	1418 FNL	1980 FWL	330 FNL	2553 FWL	99 FNL	1982 FEL	330 FNL	1238 FEL	1424 FNL	660 FEL	100 FSL	660 FEL	100 FSL	660 FEL
New Name	New Footages	SHL		KOP		FTP		DP1 -TURN POINT 1		NPZ1		Apex- MID TURN		NPZ2		DP2-TURN POINT 2		LTP		BHL	
TOPAZ 21602 30 FED COM 3H		Sec 31 20S 34E		Sec 30 20S 34E		Sec 30 20S 34E		Sec 30 20S 34E		Sec 30 20S 34E		Sec 30 20S 34E		Sec 30 20S 34E		Sec 30 20S 34E		Sec 30 20S 34E		Sec 30 20S 34E	
		551 FNL	1223 FWL	50 FSL	350 FWL	100 FSL	350 FWL	750 FNL	350 FWL	330 FNL	503 FWL	100 FNL	1000 FWL	330 FNL	1495 FWL	750 FNL	1650 FWL	100 FSL	1650 FWL	50 FSL	1650 FWL

<p>C-102</p> <p>Submit Electronically Via OCD Permitting</p>	<p>State of New Mexico Energy, Minerals, & Natural Resources Department OIL CONSERVATION DIVISION</p>	<p>Revised July 9, 2024 PAGE 1 OF 2</p>		
		<table border="1" style="width:100%; border-collapse: collapse;"> <tr> <td style="width:10%; text-align: right;">Submittal Type:</td> <td> <input checked="" type="checkbox"/> Initial Submittal <input type="checkbox"/> Amended Report <input type="checkbox"/> As Drilled </td> </tr> </table>	Submittal Type:	<input checked="" type="checkbox"/> Initial Submittal <input type="checkbox"/> Amended Report <input type="checkbox"/> As Drilled
Submittal Type:	<input checked="" type="checkbox"/> Initial Submittal <input type="checkbox"/> Amended Report <input type="checkbox"/> As Drilled			

WELL LOCATION INFORMATION

API Number 30-025-55821	Pool Code 97895	Pool Name WC-025 G-08 S213304D; Bone Springs
Property Code 339126	Property Name TOPAZ 21602 30 FED COM	
OGRID No. 260297	Operator Name BTA OIL PRODUCERS, LLC	Well Number 3H
Ground Level Elevation 3692'		
Surface Owner: <input type="checkbox"/> State <input type="checkbox"/> Fee <input type="checkbox"/> Tribal <input checked="" type="checkbox"/> Federal		Mineral Owner: <input type="checkbox"/> State <input type="checkbox"/> Fee <input type="checkbox"/> Tribal <input checked="" type="checkbox"/> Federal

Surface Location

UL	Section	Township	Range	Lot	Ft. from N/S	Ft. from E/W	Latitude (NAD83)	Longitude (NAD83)	County
D	31	20S	34E	1	551' FNL	1223' FWL	32.53534734	-103.60421283	LEA

Bottom Hole Location

UL	Section	Township	Range	Lot	Ft. from N/S	Ft. from E/W	Latitude (NAD83)	Longitude (NAD83)	County
N	30	20S	34E		50' FSL	1650' FWL	32.53700143	-103.60282720	LEA

Dedicated Acres 320.56	Infill or Defining Well Infill	Defining Well API	Overlapping Spacing Unit (Y/N) N	Consolidation Code C
Order Numbers:			Well setbacks are under Common Ownership: <input type="checkbox"/> Yes <input type="checkbox"/> No	

Kick Off Point (KOP)

UL	Section	Township	Range	Lot	Ft. from N/S	Ft. from E/W	Latitude (NAD83)	Longitude (NAD83)	County
M	30	20S	34E	4	50' FSL	350' FWL	32.53699161	-103.60704546	LEA



First Take Point (FTP)

UL	Section	Township	Range	Lot	Ft. from N/S	Ft. from E/W	Latitude (NAD83)	Longitude (NAD83)	County
M	30	20S	34E	4	100' FSL	350' FWL	32.53712904	-103.60704545	LEA

Last Take Point (LTP)

UL	Section	Township	Range	Lot	Ft. from N/S	Ft. from E/W	Latitude (NAD83)	Longitude (NAD83)	County
N	30	20S	34E		100' FSL	1650' FWL	32.53713886	-103.60282723	LEA

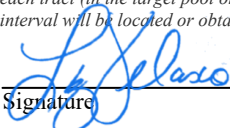
Unitized Area or Area of Uniform Interest Com Agreement pending	Spacing Unit Type: <input checked="" type="checkbox"/> Horizontal <input type="checkbox"/> Vertical	Ground Floor Elevation 3692'
--	---	---------------------------------

<p>OPERATOR CERTIFICATIONS</p> <p><i>I hereby certify that the information contained herein is true and complete to the best of my knowledge and belief, and, if the well is a vertical or directional well, that this organization either owns a working interest or unleased mineral interest in the land including the proposed bottom hole location or has a right to drill this well at this location pursuant to a contract with an owner of a working interest or unleased mineral interest, or to a voluntary pooling agreement or a compulsory pooling order heretofore entered by the division.</i></p> <p><i>If this well is a horizontal well, I further certify that this organization has received the consent of at least one lessee or owner of a working interest or unleased mineral interest in each tract (in the target pool or formation) in which any part of the well's completed interval will be located or obtained a compulsory pooling order from the division.</i></p> <p>Signature: <u></u> Date: <u>2/24/2026</u></p> <p>Printed Name: <u>LIZ VELASCO</u></p> <p>Email Address: <u>lvelasco@btaoil.com</u></p>	<p>SURVEYOR CERTIFICATIONS</p> <p><i>I hereby certify that the well location shown on this plat was plotted from field notes of actual surveys made by me or under my supervision, and that the same is true and correct to the best of my belief.</i></p> <div style="text-align: center;">  </div> <p>Signature and Seal of Professional Surveyor: <u></u></p> <table border="1" style="width:100%; border-collapse: collapse;"> <tr> <td style="width:50%;">Certificate Number 29049</td> <td style="width:50%;">Date of Survey FEBRUARY 23, 2026</td> </tr> </table>	Certificate Number 29049	Date of Survey FEBRUARY 23, 2026
Certificate Number 29049	Date of Survey FEBRUARY 23, 2026		

Note: No allowable will be assigned to this completion until all interests have been consolidated or a non-standard unit has been approved by the division.

TOPAZ 21602 30 FED COM 3H

ACREAGE DEDICATION PLATS

<p>NPZ-1 FNL 330' FWL 503', SECTION 30 NAD 83, SPCS NM EAST X:765277.53' / Y:564749.31' LAT:32.55045195 / LON:-103.60655104 NAD 27, SPCS NM EAST X:724096.49' / Y:564687.08' LAT:32.55032908 / LON:-103.60606000</p>	<p>BHL FSL 50' FWL 1650', SECTION 30 NAD 83, SPCS NM EAST X:766458.53' / Y:559863.70' LAT:32.53700143 / LON:-103.60282720 NAD 27, SPCS NM EAST X:725277.34' / Y:559801.61' LAT:32.53687851 / LON:-103.60233680</p>
<p>TURN POINT-1 FNL 750' FWL 350', SECTION 30 NAD 83, SPCS NM EAST X:765127.70' / Y:564327.83' LAT:32.54929630 / LON:-103.60704660 NAD 27, SPCS NM EAST X:723946.65' / Y:564265.61' LAT:32.54917344 / LON:-103.60655559</p>	<p>LTP FSL 100' FWL 1650', SECTION 30 NAD 83, SPCS NM EAST X:766458.18' / Y:559913.70' LAT:32.53713886 / LON:-103.60282723 NAD 27, SPCS NM EAST X:725277.00' / Y:559851.61' LAT:32.53701594 / LON:-103.60233682</p>
<p>PPP-2 FNL 1319' FWL 350', SECTION 30 NAD 83, SPCS NM EAST X:765131.63' / Y:563758.69' LAT:32.54773192 / LON:-103.60704644 NAD 27, SPCS NM EAST X:723950.57' / Y:563696.49' LAT:32.54760905 / LON:-103.60655499</p>	<p>PPP-3 FNL 1319' FWL 1650', SECTION 30 NAD 83, SPCS NM EAST X:766431.57' / Y:563771.31' LAT:32.54774217 / LON:-103.60282772 NAD 27, SPCS NM EAST X:725250.49' / Y:563709.10' LAT:32.54761926 / LON:-103.60233691</p>
<p>FTP/PPP-1 FSL 100' FWL 350', SECTION 30 NAD 83, SPCS NM EAST X:765158.24' / Y:559901.24' LAT:32.53712904 / LON:-103.60704545 NAD 27, SPCS NM EAST X:723977.07' / Y:559839.16' LAT:32.53700616 / LON:-103.60655491</p>	<p>TURN POINT-2 FNL 750' FWL 1650', SECTION 30 NAD 83, SPCS NM EAST X:766427.65' / Y:564340.45' LAT:32.54930655 / LON:-103.60282777 NAD 27, SPCS NM EAST X:725246.59' / Y:564278.23' LAT:32.54918365 / LON:-103.60233690</p>
<p>KOP FSL 50' FWL 350', SECTION 30 NAD 83, SPCS NM EAST X:765158.58' / Y:559851.24' LAT:32.53699161 / LON:-103.60704546 NAD 27, SPCS NM EAST X:723977.41' / Y:559789.16' LAT:32.53686873 / LON:-103.60655492</p>	<p>NPZ-2 FNL 330' FWL 1495', SECTION 30 NAD 83, SPCS NM EAST X:766269.66' / Y:564758.94' LAT:32.55045976 / LON:-103.60333116 NAD 27, SPCS NM EAST X:725088.61' / Y:564696.70' LAT:32.55033687 / LON:-103.60284023</p>
<p>SHL FNL 551' FWL 1223', SECTION 31 NAD 83, SPCS NM EAST X:766035.63' / Y:559259.00' LAT:32.53534734 / LON:-103.60421283 NAD 27, SPCS NM EAST X:724854.43' / Y:559196.93' LAT:32.53522443 / LON:-103.60372244</p>	<p>MID TURN FNL 100' FWL 1000', SECTION 30 NAD 83, SPCS NM EAST X:765773.19' / Y:564984.13' LAT:32.55108805 / LON:-103.60493731 NAD 27, SPCS NM EAST X:724592.16' / Y:564921.89' LAT:32.55096517 / LON:-103.60444630</p>

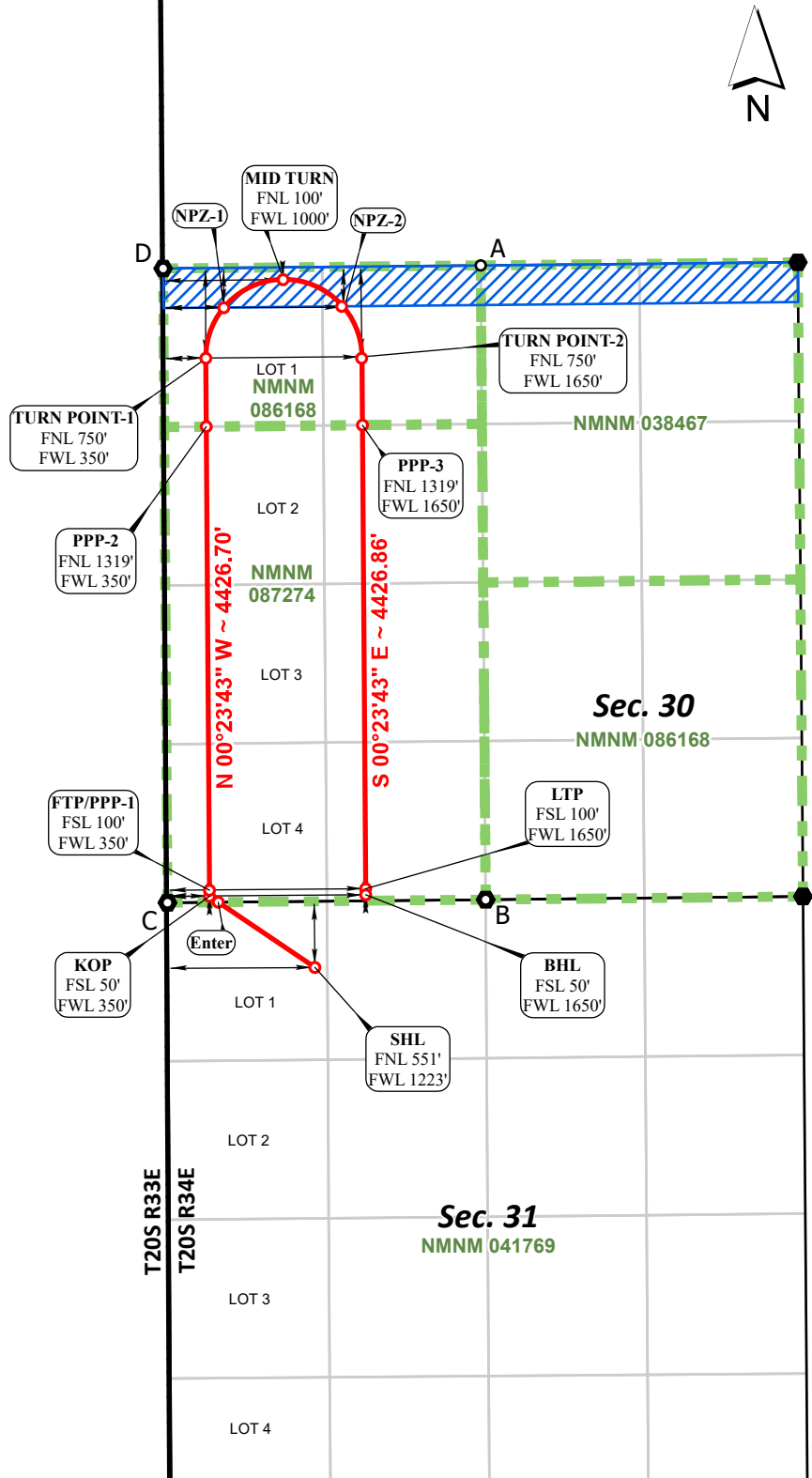

*FTP TO LTP LEASE DISTANCES

TRACT	DISTANCE
NMNM 087274	7715.25'
NMNM 086168	3180.36'
TOTAL	10895.61'

ARC DIMENSIONS	
ARC LENGTH	2042.04'
RADIUS	650.00'
DELTA ANGLE	180°00'00"
CHORD BEARING	S 89°26'38" W
CHORD LENGTH	1,300.01'

CORNER COORDINATES NAD 83, SPCS NM EAST	CORNER COORDINATES NAD 27, SPCS NM EAST
A - X: 767415.87' / Y:565100.08'	A - X: 726234.82' / Y:565037.83'
B - X: 767457.20' / Y:559823.27'	B - X: 726276.00' / Y:559761.18'
C - X: 764808.94' / Y:559797.88'	C - X: 723627.77' / Y:559735.80'
D - X: 764772.54' / Y:565074.42'	D - X: 723591.52' / Y:565012.18'



○ Drill Line Events ● Section Corners — Drill Line ← Dimension Lines □ Federal Leases □ Project Area
All bearings and coordinates refer to New Mexico State Plane Coordinate System, East Zone, U.S. Survey Feet.

JOB No. 20251425
REV 2 ANC 2/19/2026

Distances/areas relative to NAD 83 grid measurements. Combined Scale Factor: 0.999789804 and a Convergence Angle: 0.390032294°

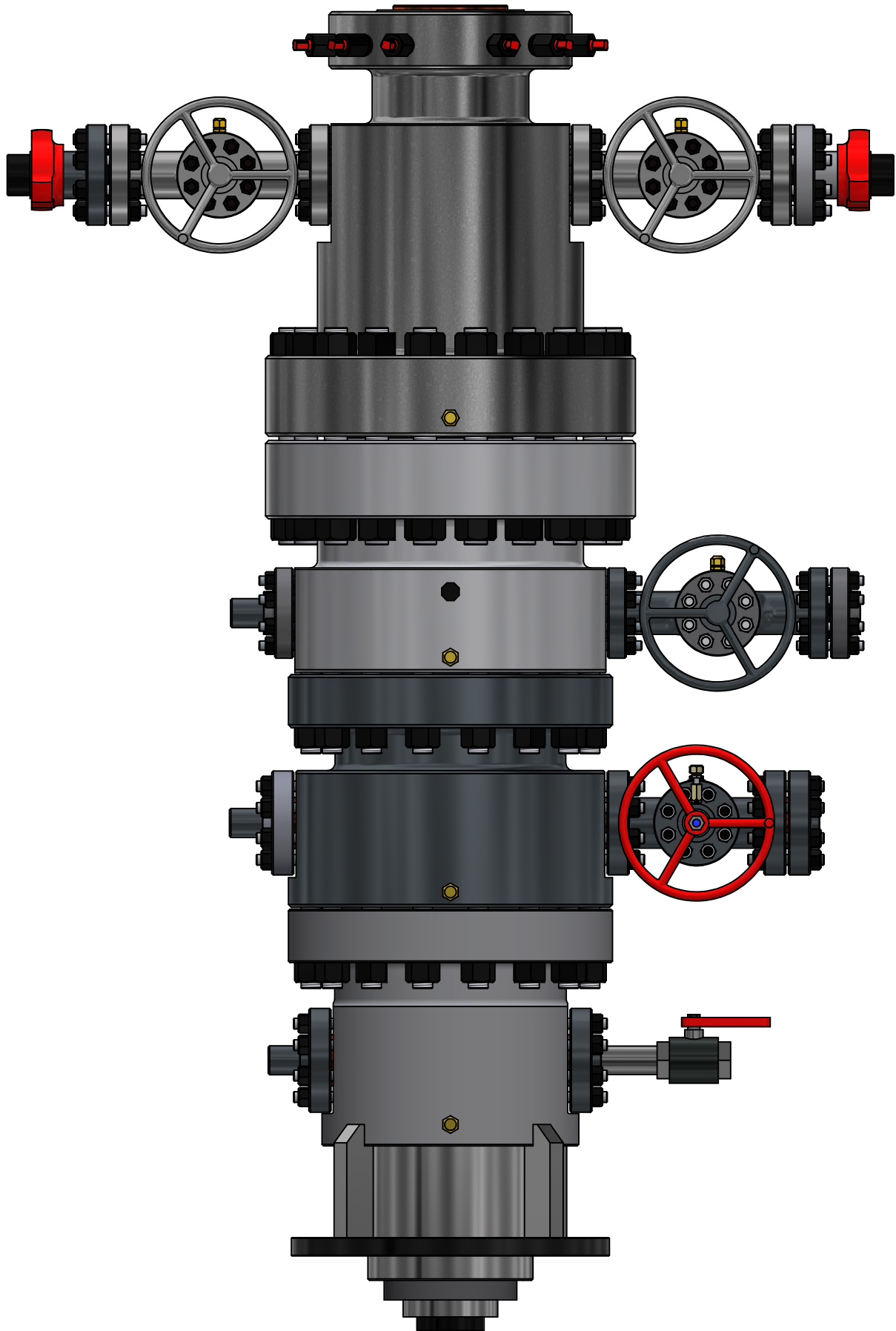

**SONIC
CONNECTORS**

This document includes the proprietary and confidential information of Sonic Connectors Ltd. The information in it shall not be reproduced, used and / or disclosed in any manner or for any purpose unless it is for reference to work under contracts and / or proposal submitted by Sonic Connectors Ltd. This document shall be returned to Sonic Connector Ltd. upon request.

DESCRIPTION

**BTM
MB2 MULTI BOWL
4 STRING STACK UP
13-5K -- 13-10K**

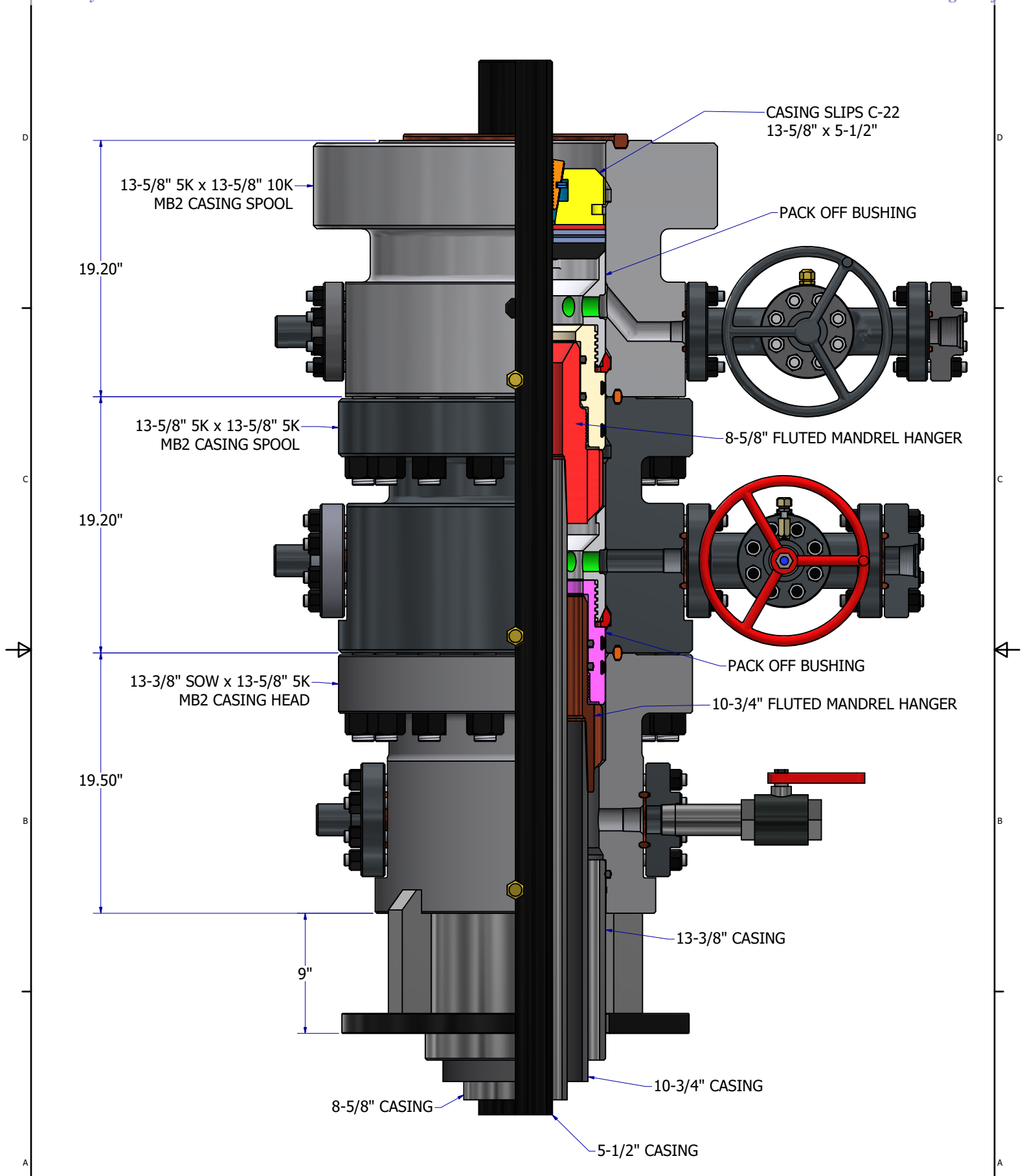

This document includes the proprietary and confidential information of Sonic Connectors Ltd. The information in it shall not be reproduced, used and / or disclosed in any manner or for any purpose unless it is for reference to work under contracts and / or proposal submitted by Sonic Connectors Ltd. This document shall be returned to Sonic Connector Ltd. upon request.

DESCRIPTION
BTA
MB2 MULTI BOWL
4 STRING STACK UP
13-5K -- 13-10K

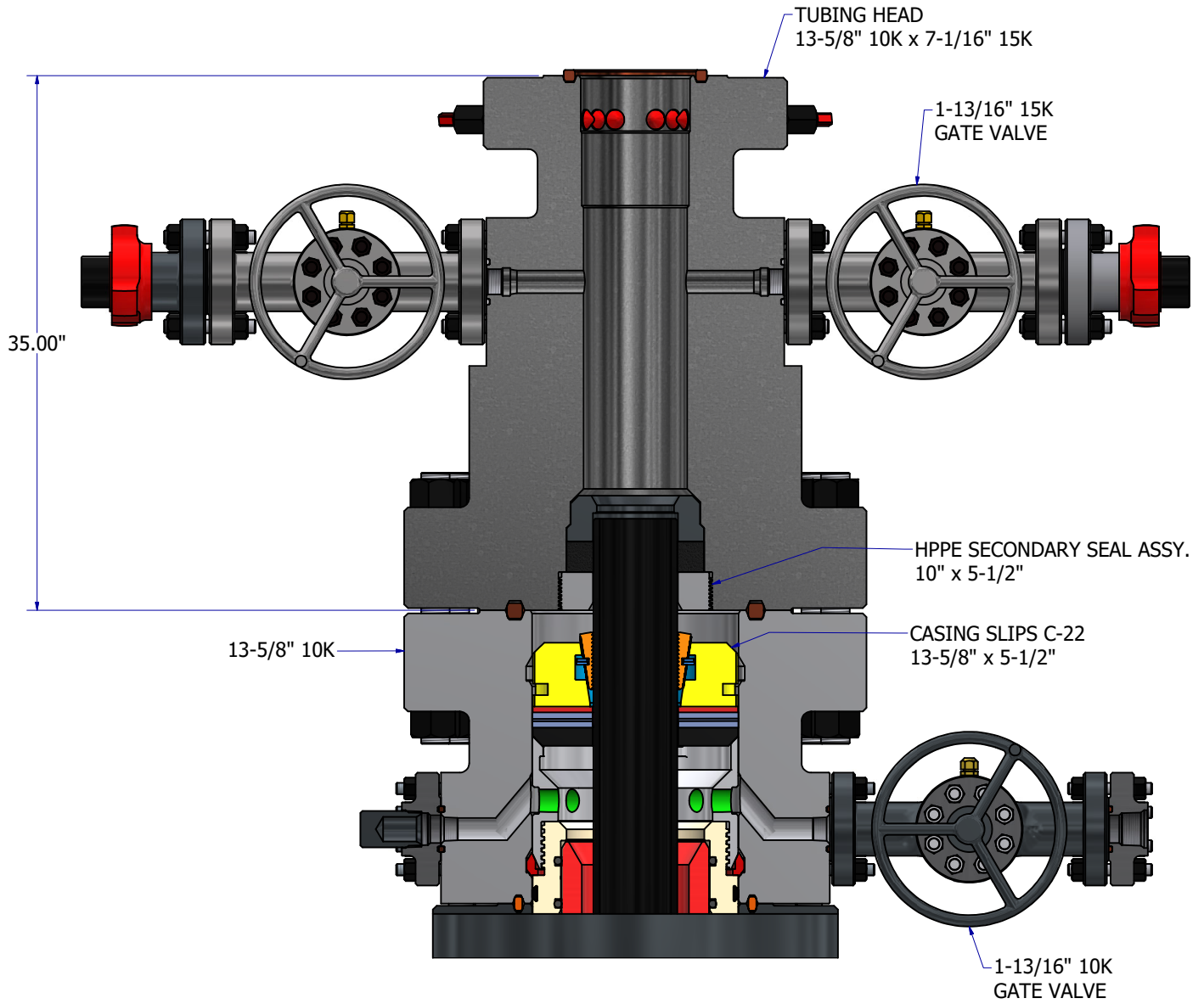

This document includes the proprietary and confidential information of Sonic Connectors Ltd. The information in it shall not be reproduced, used and / or disclosed in any manner or for any purpose unless it is for reference to work under contracts and / or proposal submitted by Sonic Connectors Ltd. This document shall be returned to Sonic Connector Ltd. upon request.

DESCRIPTION
BTB
MB2 MULTI BOWL
4 STRING STACK UP
13-5K -- 13-10K

POWERTRACK

HYDROSTATIC TESTING REPORT

LTYY/QR-5.7.1-28

No: 240319005

Product Name	Choke And Kill Hose	Standard	API Spec 16C 3 rd edition
Product Specification	3" × 10000psi × 60ft (18.29m)	Serial Number	7660218
Inspection Equipment	MTU-BS-1600-3200-E	Test medium	Water
Inspection Department	Q.C. Department	Inspection Date	2024.03.19
Rate of length change			
Standard requirements	At working pressure ,the rate of length change should not more than ±2%		
Testing result	10000psi (69.0MPa) ,Rate of length change 0.7%		
Hydrostatic testing			
Standard requirements	At 1.5 times working pressure, the initial pressure-holding period of not less than three minutes, the second pressure-holding period of not less than one hour, no leaks.		
Testing result	15000psi (103.5MPa), 3 min for the first time, 60 min for the second time, no leakage		
Graph of pressure testing:			
Conclusion	The inspected items meet standard requirements of API Spec 16C 3 rd edition		
Approver	Jane C	Auditor	Alice D
		Inspector	Leo W
LUOHE LETONE HYDRAULICS TECHNOLOGY CO.,LTD			



CERTIFICATE OF QUALITY

LTYYY/QR-5.7.1-19B

No: LT2024-030-025

Customer Name	Austin Hose		
Product Name	Choke And Kill Hose		
Product Specification	3" × 10000psi × 60ft (18.29m)	Quantity	2PCS
Serial Number	7660217、7660218	FSL	FSL3
Temperature Range	-29℃ ~ +121℃	Standard	API Spec 16C 3 rd edition
Inspection Department	Q.C. Department	Inspection date	2024.03.19

Inspection Items	Inspection results				
Appearance Checking	In accordance with API Spec 16C 3 rd edition				
Size and Lengths	In accordance with API Spec 16C 3 rd edition				
Dimensions and Tolerances	In accordance with API Spec 16C 3 rd edition				
End Connections: 4-1/16"×10000psi Integral flange for sour gas service	In accordance with API Spec 6A 21 st edition				
End Connections: 4-1/16"×10000psi Integral flange for sour gas service	In accordance with API Spec 17D 3 rd edition				
Hydrostatic Testing	In accordance with API Spec 16C 3 rd edition				
product Marking	In accordance with API Spec 16C 3 rd edition				
Inspection conclusion	The inspected items meet standard requirements of API Spec 16C 3 rd edition				
Remarks					
Approver	Jane C	Auditor	Alice D	Inspector	Leo W
LUOHE LETONE HYDRAULICS TECHNOLOGY CO.,LTD					



CERTIFICATE OF CONFORMANCE

No:LT240319006

Product Name: Choke And Kill Hose

Product Specification: 3"×10000psi×60ft (18.29m)

Serial Number: 7660217、7660218

End Connections: 4-1/16"×10000psi Integral flange for sour gas service

The Choke And Kill Hose assembly was produced by LUOHE LETONE HYDRAULICS TECHNOLOGY CO.,LTD.in Mar, 2024, and inspected by LUOHE LETONE HYDRAULICS TECHNOLOGY CO.,LTD. according to API Spec 16C 3rd edition on Mar 19, 2024. The overall condition is good. This is to certify that the Choke And Kill Hose complies with all current standards and specifications for API Spec 16C 3rd edition .

QC Manager:

Jane C

Date:Mar 19, 2024

LUOHE LETONE HYDRAULICS TECHNOLOGY CO.,LTD



POWERTRACK

HYDROSTATIC TESTING REPORT

LTTY/QR-5.7.1-28

No: 24032201

Product Name	Choke And Kill Hose	Standard	API Spec 16C 3 rd edition
Product Specification	3"×10000psi×35ft (10.67m)	Serial Number	7660198
Inspection Equipment	MTU-BS-1600-3200-E	Test medium	Water
Inspection Department	Q.C. Department	Inspection Date	2024.03.22

Rate of length change

Standard requirements	At working pressure ,the rate of length change should not more than $\pm 2\%$
Testing result	10000psi (69.0MPa) ,Rate of length change 0.7%

Hydrostatic testing

Standard requirements	At 1.5 times working pressure, the initial pressure-holding period of not less than three minutes, the second pressure-holding period of not less than one hour, no leaks.
Testing result	15000psi (103.5MPa), 3 min for the first time, 60 min for the second time, no leakage

Graph of pressure testing:

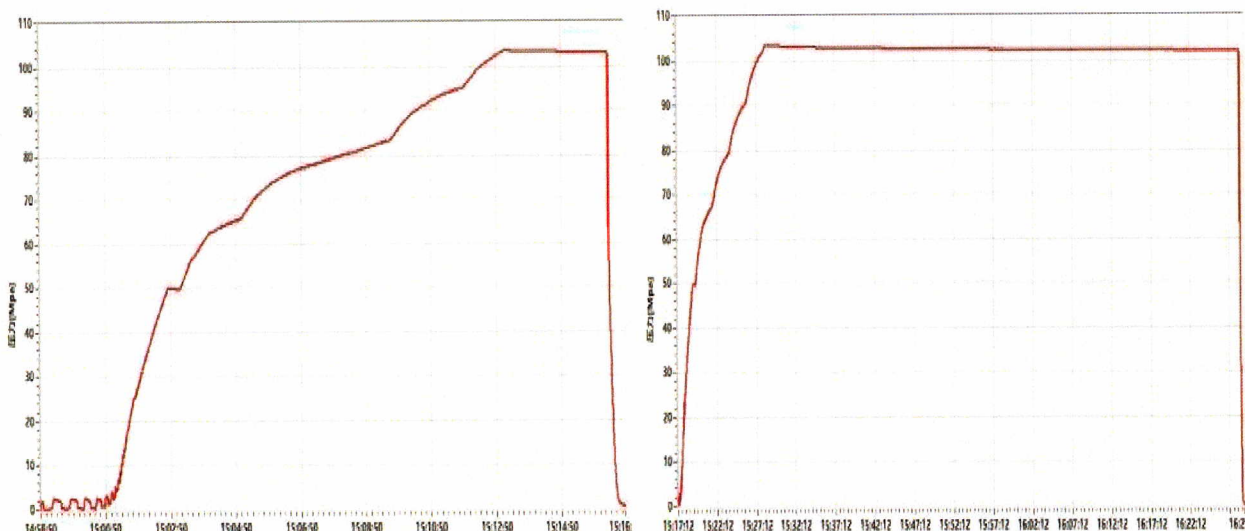

Conclusion	The inspected items meet standard requirements of API Spec 16C 3 rd edition				16C-0403
Approver	Jane C	Auditor	Alice D	Inspector	Leo W

<p>LUOHE LETONE HYDRAULICS TECHNOLOGY CO.,LTD</p>	
---	--





CERTIFICATE OF QUALITY

LTYQ/QR-5.7.1-19B

No: LT2024-030-024

Customer Name	Austin Hose		
Product Name	Choke And Kill Hose		
Product Specification	3"×10000psi×35ft (10.67m)	Quantity	3PCS
Serial Number	7660198、7660200、7660202	FSL	FSL3
Temperature Range	-29℃~+121℃	Standard	API Spec 16C 3 rd edition
Inspection Department	Q.C. Department	Inspection date	2024.03.22

Inspection Items	Inspection results				
Appearance Checking	In accordance with API Spec 16C 3 rd edition				
Size and Lengths	In accordance with API Spec 16C 3 rd edition				
Dimensions and Tolerances	In accordance with API Spec 16C 3 rd edition				
End Connections: 4-1/16"×10000psi Integral flange for sour gas service	In accordance with API Spec 6A 21 st edition				
End Connections: 4-1/16"×10000psi Integral flange for sour gas service	In accordance with API Spec 17D 3 rd edition				
Hydrostatic Testing	In accordance with API Spec 16C 3 rd edition				
product Marking	In accordance with API Spec 16C 3 rd edition				
Inspection conclusion	The inspected items meet standard requirements of API Spec 16C 3 rd edition				
Remarks	16C-0403 				
Approver	Jane C	Auditor	Alice D	Inspector	Leo W
LUOHE LETONE HYDRAULICS TECHNOLOGY CO.,LTD					

POWERTRACK

CERTIFICATE OF CONFORMANCE

№:LT24032204

Product Name: Choke And Kill Hose

Product Specification: 3"×10000psi×35ft(10.67m)

Serial Number: 7660198、7660200、7660202

End Connections: 4-1/16"×10000psi Integral flange for sour gas service

The Choke And Kill Hose assembly was produced by LUOHE LETONE HYDRAULICS TECHNOLOGY CO.,LTD.in Mar,2024, and inspected by LUOHE LETONE HYDRAULICS TECHNOLOGY CO.,LTD. according to API Spec 16C 3rd edition on Mar 22, 2024. The overall condition is good. This is to certify that the Choke And Kill Hose complies with all current standards and specifications for API Spec 16C 3rd edition .

QC Manager:

Jane C

Date:Mar 22, 2024

16C-0403 

LUOHE LETONE HYDRAULICS TECHNOLOGY CO.,LTD

 **LETONE**

BOP Break Testing Request

BTA requests permission to allow BOP Break Testing under the following conditions:

- After a full BOP test is conducted on the first well on the pad.
- When skidding to drill a hole section that does not penetrate into the Wolfcamp.
- Full BOP test will be required prior to drilling any production hole.
- If the previous full BOP test was more than 21 days prior, then break test is not allowed and a full test is required. Break testing will only be performed on 5M BOPE and is not allowed for 10M BOPE.



TUBING REQUIREMENTS

BTA Oil Producers, LLC respectfully requests an exception to the following NMOCD rule:

- 19.15.16.10 Casing AND TUBING RQUIREMENTS:

J (3): “The operator shall set tubing as near the bottom as practical and tubing perforations shall not be more than 250 feet above top of pay zone.”

With horizontal flowing and gas lifted wells an end of tubing depth placed at or slightly above KOP is a conservative way to ensure the tubing stays clean from debris, plugging, and allows for fewer well interventions post offset completion. The deeper the tubulars are run into the curve, the higher the probability is that the tubing will become stuck in sand and or well debris as the well produces over time. An additional consideration for EOT placement during artificial lift installations is avoiding the high dog leg severity and inclinations found in the curve section of the wellbore to help improve reliability and performance. Dog leg severity and inclinations tend not to hamper gas lifted or flowing wells, but they do affect other forms of artificial lift like rod pump or ESP (electric submersible pump). Keeping the EOT above KOP is an industry best practice for those respective forms of artificial lift.



BTA Oil Producers, LLC

Lea County, NM (NAD83 NME)

Topaz 21602 30 Fed Com

Topaz 21602 30 Fed Com 3H

OH

Plan: Plan 1 12-23-25

Standard Planning Report

23 December, 2025





Phoenix Technology Services
Planning Report



Database:	USAEDMDB	Local Co-ordinate Reference:	Well Topaz 21602 30 Fed Com 3H
Company:	BTA Oil Producers, LLC	TVD Reference:	RKB @ 3715.50usft (Citadel 4)
Project:	Lea County, NM (NAD83 NME)	MD Reference:	RKB @ 3715.50usft (Citadel 4)
Site:	Topaz 21602 30 Fed Com	North Reference:	Grid
Well:	Topaz 21602 30 Fed Com 3H	Survey Calculation Method:	Minimum Curvature
Wellbore:	OH		
Design:	Plan 1 12-23-25		

Project	Lea County, NM (NAD83 NME)		
Map System:	US State Plane 1983	System Datum:	Mean Sea Level
Geo Datum:	North American Datum 1983		
Map Zone:	New Mexico Eastern Zone		

Site	Topaz 21602 30 Fed Com				
Site Position:		Northing:	559,272.74 usft	Latitude:	32° 32' 7.390341 N
From:	Map	Easting:	765,977.23 usft	Longitude:	103° 36' 15.847232 W
Position Uncertainty:	0.00 usft	Slot Radius:	13-3/16 "	Grid Convergence:	0.392 °

Well	Topaz 21602 30 Fed Com 3H					
Well Position	+N/-S	-13.74 usft	Northing:	559,259.00 usft	Latitude:	32° 32' 7.250432 N
	+E/-W	58.40 usft	Easting:	766,035.63 usft	Longitude:	103° 36' 15.166172 W
Position Uncertainty		1.00 usft	Wellhead Elevation:		Ground Level:	3,692.00 usft

Wellbore	OH				
Magnetics	Model Name	Sample Date	Declination (°)	Dip Angle (°)	Field Strength (nT)
	HDGM	2/22/2026	6.083	60.200	47,379.00000000

Design	Plan 1 12-23-25			
Audit Notes:				
Version:	Phase:	PLAN	Tie On Depth:	0.00
Vertical Section:	Depth From (TVD) (usft)	+N/-S (usft)	+E/-W (usft)	Direction (°)
	0.00	0.00	0.00	359.60

Plan Survey Tool Program	Date	12/23/2025		
Depth From (usft)	Depth To (usft)	Survey (Wellbore)	Tool Name	Remarks
1	0.00	22,115.19 Plan 1 12-23-25 (OH)	SQC_C705Mb_MWD+IFR'	MWD+IFR1+Sag+FDIR



Phoenix Technology Services
Planning Report



Database:	USAEDMDB	Local Co-ordinate Reference:	Well Topaz 21602 30 Fed Com 3H
Company:	BTA Oil Producers, LLC	TVD Reference:	RKB @ 3715.50usft (Citadel 4)
Project:	Lea County, NM (NAD83 NME)	MD Reference:	RKB @ 3715.50usft (Citadel 4)
Site:	Topaz 21602 30 Fed Com	North Reference:	Grid
Well:	Topaz 21602 30 Fed Com 3H	Survey Calculation Method:	Minimum Curvature
Wellbore:	OH		
Design:	Plan 1 12-23-25		

Plan Sections										
Measured Depth (usft)	Inclination (°)	Azimuth (°)	Vertical Depth (usft)	+N/-S (usft)	+E/-W (usft)	Dogleg Rate (°/100usft)	Build Rate (°/100usft)	Turn Rate (°/100usft)	TFO (°)	Target
0.00	0.00	0.00	0.00	0.00	0.00	0.00	0.00	0.00	0.00	
2,020.00	0.00	0.00	2,020.00	0.00	0.00	0.00	0.00	0.00	0.00	
2,520.00	10.00	305.64	2,517.47	25.36	-35.37	2.00	2.00	0.00	305.639	
7,872.05	10.00	305.64	7,788.20	566.88	-790.68	0.00	0.00	0.00	0.00	
8,372.05	0.00	0.00	8,285.67	592.24	-826.05	2.00	-2.00	0.00	180.000	
10,788.64	0.00	0.00	10,702.26	592.24	-826.05	0.00	0.00	0.00	0.00	
11,694.34	90.57	355.35	11,275.19	1,168.99	-872.96	10.00	10.00	0.00	355.350	
11,906.67	90.57	359.60	11,273.07	1,381.06	-882.32	2.00	0.00	2.00	89.962	
13,167.90	90.57	359.60	11,260.50	2,642.19	-891.19	0.00	0.00	0.00	0.000	WP2 - T 21602 30 F
13,182.41	90.86	359.60	11,260.32	2,656.71	-891.29	2.00	2.00	0.05	1.560	
14,168.00	90.86	359.60	11,245.50	3,642.16	-898.09	0.00	0.00	0.00	0.000	WP3 - T 21602 30 F
14,196.95	91.44	359.60	11,244.92	3,671.10	-898.29	2.00	2.00	0.00	-0.006	
15,168.32	91.44	359.60	11,220.50	4,642.14	-904.99	0.00	0.00	0.00	0.000	WP4 - T 21602 30 F
15,173.24	91.34	359.60	11,220.38	4,647.06	-905.02	2.00	-2.00	0.00	179.999	
15,595.14	91.34	359.60	11,210.50	5,068.83	-907.93	0.00	0.00	0.00	0.000	TP1 - T 21602 30 F
16,051.89	92.27	39.54	11,195.50	5,490.31	-758.10	8.74	0.20	8.74	88.069	NPZ1 - T 21602 30
16,618.44	89.62	89.74	11,185.50	5,725.13	-262.44	8.87	-0.47	8.86	92.378	MT - T 21602 30 FC
17,180.82	89.42	139.06	11,190.50	5,499.94	234.03	8.77	-0.04	8.77	90.439	NPZ2 - T 21602 30
17,637.72	88.18	179.58	11,200.50	5,081.45	392.02	8.87	-0.27	8.87	92.131	TP3 - T 21602 30 F
17,657.56	88.57	179.60	11,201.06	5,061.62	392.16	2.00	2.00	0.11	3.175	
18,638.03	88.57	179.60	11,225.50	4,081.47	398.92	0.00	0.00	0.00	0.000	WP5 - T 21602 30 F
18,652.26	88.86	179.60	11,225.82	4,067.25	399.02	2.00	2.00	0.00	-0.045	
19,638.23	88.86	179.60	11,245.50	3,081.50	405.82	0.00	0.00	0.00	0.000	WP6 - T 21602 30 F
19,667.19	89.44	179.60	11,245.93	3,052.54	406.02	2.00	2.00	0.00	0.029	
20,638.28	89.44	179.60	11,255.50	2,081.52	412.72	0.00	0.00	0.00	0.000	WP7 - T 21602 30 F
20,638.70	89.43	179.60	11,255.50	2,081.10	412.72	2.00	-2.00	0.00	-179.944	
21,638.33	89.43	179.60	11,265.50	1,081.55	419.61	0.00	0.00	0.00	0.000	WP8 - T 21602 30 F
21,667.89	90.02	179.60	11,265.64	1,051.99	419.81	2.00	2.00	0.00	-0.024	
22,115.19	90.02	179.60	11,265.50	604.70	422.90	0.00	0.00	0.00	0.000	BHL - T 21602 30 F



Phoenix Technology Services

Planning Report



Database:	USAEDMDB	Local Co-ordinate Reference:	Well Topaz 21602 30 Fed Com 3H
Company:	BTA Oil Producers, LLC	TVD Reference:	RKB @ 3715.50usft (Citadel 4)
Project:	Lea County, NM (NAD83 NME)	MD Reference:	RKB @ 3715.50usft (Citadel 4)
Site:	Topaz 21602 30 Fed Com	North Reference:	Grid
Well:	Topaz 21602 30 Fed Com 3H	Survey Calculation Method:	Minimum Curvature
Wellbore:	OH		
Design:	Plan 1 12-23-25		

Planned Survey										
Measured Depth (usft)	Inclination (°)	Azimuth (°)	Vertical Depth (usft)	+N/-S (usft)	+E/-W (usft)	Vertical Section (usft)	Dogleg Rate (°/100usft)	Build Rate (°/100usft)	Turn Rate (°/100usft)	
0.00	0.00	0.00	0.00	0.00	0.00	0.00	0.00	0.00	0.00	0.00
1,535.50	0.00	0.00	1,535.50	0.00	0.00	0.00	0.00	0.00	0.00	0.00
RUSTLER										
2,020.00	0.00	0.00	2,020.00	0.00	0.00	0.00	0.00	0.00	0.00	0.00
KOP, Begin 2.00°/100' Build										
2,100.00	1.60	305.64	2,099.99	0.65	-0.91	0.66	2.00	2.00	0.00	0.00
2,200.00	3.60	305.64	2,199.88	3.29	-4.59	3.33	2.00	2.00	0.00	0.00
2,300.00	5.60	305.64	2,299.55	7.97	-11.11	8.04	2.00	2.00	0.00	0.00
2,316.03	5.92	305.64	2,315.50	8.90	-12.42	8.99	2.00	2.00	0.00	0.00
TOP SALT										
2,400.00	7.60	305.64	2,398.89	14.66	-20.45	14.81	2.00	2.00	0.00	0.00
2,500.00	9.60	305.64	2,497.76	23.38	-32.60	23.60	2.00	2.00	0.00	0.00
2,520.00	10.00	305.64	2,517.47	25.36	-35.37	25.61	2.00	2.00	0.00	0.00
Hold 10.00° Inc at 305.64° Azm										
2,600.00	10.00	305.64	2,596.25	33.45	-46.66	33.78	0.00	0.00	0.00	0.00
2,700.00	10.00	305.64	2,694.73	43.57	-60.77	44.00	0.00	0.00	0.00	0.00
2,800.00	10.00	305.64	2,793.21	53.69	-74.89	54.21	0.00	0.00	0.00	0.00
2,900.00	10.00	305.64	2,891.69	63.81	-89.00	64.43	0.00	0.00	0.00	0.00
2,924.18	10.00	305.64	2,915.50	66.25	-92.41	66.90	0.00	0.00	0.00	0.00
BASE SALT										
3,000.00	10.00	305.64	2,990.17	73.93	-103.11	74.64	0.00	0.00	0.00	0.00
3,100.00	10.00	305.64	3,088.65	84.04	-117.22	84.86	0.00	0.00	0.00	0.00
3,200.00	10.00	305.64	3,187.13	94.16	-131.34	95.08	0.00	0.00	0.00	0.00
3,300.00	10.00	305.64	3,285.62	104.28	-145.45	105.29	0.00	0.00	0.00	0.00
3,400.00	10.00	305.64	3,384.10	114.40	-159.56	115.51	0.00	0.00	0.00	0.00
3,500.00	10.00	305.64	3,482.58	124.52	-173.67	125.73	0.00	0.00	0.00	0.00
3,600.00	10.00	305.64	3,581.06	134.63	-187.79	135.94	0.00	0.00	0.00	0.00
3,700.00	10.00	305.64	3,679.54	144.75	-201.90	146.16	0.00	0.00	0.00	0.00
3,800.00	10.00	305.64	3,778.02	154.87	-216.01	156.37	0.00	0.00	0.00	0.00
3,900.00	10.00	305.64	3,876.50	164.99	-230.12	166.59	0.00	0.00	0.00	0.00
4,000.00	10.00	305.64	3,974.98	175.11	-244.24	176.81	0.00	0.00	0.00	0.00
4,100.00	10.00	305.64	4,073.46	185.22	-258.35	187.02	0.00	0.00	0.00	0.00
4,200.00	10.00	305.64	4,171.94	195.34	-272.46	197.24	0.00	0.00	0.00	0.00
4,300.00	10.00	305.64	4,270.42	205.46	-286.57	207.46	0.00	0.00	0.00	0.00
4,400.00	10.00	305.64	4,368.90	215.58	-300.69	217.67	0.00	0.00	0.00	0.00
4,500.00	10.00	305.64	4,467.38	225.70	-314.80	227.89	0.00	0.00	0.00	0.00
4,600.00	10.00	305.64	4,565.87	235.81	-328.91	238.10	0.00	0.00	0.00	0.00
4,700.00	10.00	305.64	4,664.35	245.93	-343.02	248.32	0.00	0.00	0.00	0.00
4,800.00	10.00	305.64	4,762.83	256.05	-357.14	258.54	0.00	0.00	0.00	0.00
4,900.00	10.00	305.64	4,861.31	266.17	-371.25	268.75	0.00	0.00	0.00	0.00
5,000.00	10.00	305.64	4,959.79	276.29	-385.36	278.97	0.00	0.00	0.00	0.00
5,100.00	10.00	305.64	5,058.27	286.40	-399.47	289.19	0.00	0.00	0.00	0.00
5,200.00	10.00	305.64	5,156.75	296.52	-413.59	299.40	0.00	0.00	0.00	0.00
5,300.00	10.00	305.64	5,255.23	306.64	-427.70	309.62	0.00	0.00	0.00	0.00
5,400.00	10.00	305.64	5,353.71	316.76	-441.81	319.83	0.00	0.00	0.00	0.00
5,500.00	10.00	305.64	5,452.19	326.88	-455.92	330.05	0.00	0.00	0.00	0.00
5,600.00	10.00	305.64	5,550.67	336.99	-470.04	340.27	0.00	0.00	0.00	0.00
5,700.00	10.00	305.64	5,649.15	347.11	-484.15	350.48	0.00	0.00	0.00	0.00
5,800.00	10.00	305.64	5,747.63	357.23	-498.26	360.70	0.00	0.00	0.00	0.00
5,807.99	10.00	305.64	5,755.50	358.04	-499.39	361.52	0.00	0.00	0.00	0.00
DELAWARE										
5,900.00	10.00	305.64	5,846.12	367.35	-512.37	370.92	0.00	0.00	0.00	0.00
5,939.99	10.00	305.64	5,885.50	371.39	-518.02	375.00	0.00	0.00	0.00	0.00



Phoenix Technology Services

Planning Report



Database:	USAEDMDB	Local Co-ordinate Reference:	Well Topaz 21602 30 Fed Com 3H
Company:	BTA Oil Producers, LLC	TVD Reference:	RKB @ 3715.50usft (Citadel 4)
Project:	Lea County, NM (NAD83 NME)	MD Reference:	RKB @ 3715.50usft (Citadel 4)
Site:	Topaz 21602 30 Fed Com	North Reference:	Grid
Well:	Topaz 21602 30 Fed Com 3H	Survey Calculation Method:	Minimum Curvature
Wellbore:	OH		
Design:	Plan 1 12-23-25		

Planned Survey									
Measured Depth (usft)	Inclination (°)	Azimuth (°)	Vertical Depth (usft)	+N/-S (usft)	+E/-W (usft)	Vertical Section (usft)	Dogleg Rate (°/100usft)	Build Rate (°/100usft)	Turn Rate (°/100usft)
BELL CANYON									
6,000.00	10.00	305.64	5,944.60	377.47	-526.49	381.13	0.00	0.00	0.00
6,100.00	10.00	305.64	6,043.08	387.58	-540.60	391.35	0.00	0.00	0.00
6,200.00	10.00	305.64	6,141.56	397.70	-554.71	401.57	0.00	0.00	0.00
6,239.54	10.00	305.64	6,180.50	401.70	-560.29	405.61	0.00	0.00	0.00
CHERRY CANYON									
6,300.00	10.00	305.64	6,240.04	407.82	-568.82	411.78	0.00	0.00	0.00
6,400.00	10.00	305.64	6,338.52	417.94	-582.94	422.00	0.00	0.00	0.00
6,500.00	10.00	305.64	6,437.00	428.06	-597.05	432.21	0.00	0.00	0.00
6,579.71	10.00	305.64	6,515.50	436.12	-608.30	440.36	0.00	0.00	0.00
BRUSHY CANYON									
6,600.00	10.00	305.64	6,535.48	438.17	-611.16	442.43	0.00	0.00	0.00
6,700.00	10.00	305.64	6,633.96	448.29	-625.27	452.65	0.00	0.00	0.00
6,800.00	10.00	305.64	6,732.44	458.41	-639.39	462.86	0.00	0.00	0.00
6,900.00	10.00	305.64	6,830.92	468.53	-653.50	473.08	0.00	0.00	0.00
7,000.00	10.00	305.64	6,929.40	478.65	-667.61	483.30	0.00	0.00	0.00
7,100.00	10.00	305.64	7,027.89	488.76	-681.72	493.51	0.00	0.00	0.00
7,200.00	10.00	305.64	7,126.37	498.88	-695.84	503.73	0.00	0.00	0.00
7,300.00	10.00	305.64	7,224.85	509.00	-709.95	513.94	0.00	0.00	0.00
7,400.00	10.00	305.64	7,323.33	519.12	-724.06	524.16	0.00	0.00	0.00
7,500.00	10.00	305.64	7,421.81	529.24	-738.17	534.38	0.00	0.00	0.00
7,600.00	10.00	305.64	7,520.29	539.35	-752.29	544.59	0.00	0.00	0.00
7,700.00	10.00	305.64	7,618.77	549.47	-766.40	554.81	0.00	0.00	0.00
7,800.00	10.00	305.64	7,717.25	559.59	-780.51	565.03	0.00	0.00	0.00
7,872.05	10.00	305.64	7,788.20	566.88	-790.68	572.39	0.00	0.00	0.00
Begin 2.00°/100' Drop									
7,900.00	9.44	305.64	7,815.75	569.63	-794.51	575.16	2.00	-2.00	0.00
8,000.00	7.44	305.64	7,914.67	578.18	-806.44	583.80	2.00	-2.00	0.00
8,100.00	5.44	305.64	8,014.03	584.72	-815.56	590.40	2.00	-2.00	0.00
8,200.00	3.44	305.64	8,113.72	589.23	-821.85	594.95	2.00	-2.00	0.00
8,300.00	1.44	305.64	8,213.63	591.71	-825.31	597.46	2.00	-2.00	0.00
8,372.05	0.00	0.00	8,285.67	592.24	-826.05	597.99	2.00	-2.00	0.00
Begin Vertical Hold									
8,761.88	0.00	0.00	8,675.50	592.24	-826.05	597.99	0.00	0.00	0.00
BONE SPRING LIME									
9,766.88	0.00	0.00	9,680.50	592.24	-826.05	597.99	0.00	0.00	0.00
FIRST BONE SPRING SAND									
10,281.88	0.00	0.00	10,195.50	592.24	-826.05	597.99	0.00	0.00	0.00
SECOND BONE SPRING SAND									
10,766.88	0.00	0.00	10,680.50	592.24	-826.05	597.99	0.00	0.00	0.00
TARGET BASE_SHALE MARKER									
10,788.64	0.00	0.00	10,702.26	592.24	-826.05	597.99	0.00	0.00	0.00
KOP2, Begin 10.00°/100' Build									
10,800.00	1.14	355.35	10,713.62	592.35	-826.06	598.10	10.00	10.00	0.00
10,826.91	3.83	355.35	10,740.50	593.51	-826.15	599.27	10.00	10.00	0.00
THIRD BONE SPRING CARBONATE									
10,900.00	11.14	355.35	10,812.92	602.99	-826.92	608.75	10.00	10.00	0.00
11,000.00	21.14	355.35	10,908.86	630.66	-829.17	636.43	10.00	10.00	0.00
11,100.00	31.14	355.35	10,998.52	674.51	-832.74	680.31	10.00	10.00	0.00
11,162.94	37.43	355.35	11,050.50	709.83	-835.61	715.64	10.00	10.00	0.00
THIRD BONE SPRING SAND									
11,200.00	41.14	355.35	11,079.18	733.21	-837.52	739.04	10.00	10.00	0.00



Phoenix Technology Services

Planning Report



Database:	USAEDMDB	Local Co-ordinate Reference:	Well Topaz 21602 30 Fed Com 3H
Company:	BTA Oil Producers, LLC	TVD Reference:	RKB @ 3715.50usft (Citadel 4)
Project:	Lea County, NM (NAD83 NME)	MD Reference:	RKB @ 3715.50usft (Citadel 4)
Site:	Topaz 21602 30 Fed Com	North Reference:	Grid
Well:	Topaz 21602 30 Fed Com 3H	Survey Calculation Method:	Minimum Curvature
Wellbore:	OH		
Design:	Plan 1 12-23-25		

Planned Survey									
Measured Depth (usft)	Inclination (°)	Azimuth (°)	Vertical Depth (usft)	+N/-S (usft)	+E/-W (usft)	Vertical Section (usft)	Dogleg Rate (°/100usft)	Build Rate (°/100usft)	Turn Rate (°/100usft)
11,300.00	51.14	355.35	11,148.39	804.98	-843.35	810.85	10.00	10.00	0.00
11,400.00	61.14	355.35	11,204.04	887.64	-850.08	893.55	10.00	10.00	0.00
11,500.00	71.14	355.35	11,244.44	978.67	-857.48	984.63	10.00	10.00	0.00
11,600.00	81.14	355.35	11,268.38	1,075.32	-865.34	1,081.33	10.00	10.00	0.00
11,694.34	90.57	355.35	11,275.19	1,168.99	-872.96	1,175.06	10.00	10.00	0.00
LP, Hold 90.57° Inc, Begin 2.00°/100' Turn									
11,700.00	90.57	355.46	11,275.13	1,174.64	-873.41	1,180.70	2.00	0.00	2.00
11,800.00	90.57	357.46	11,274.14	1,274.44	-879.58	1,280.54	2.00	0.00	2.00
11,900.00	90.57	359.46	11,273.14	1,374.39	-882.26	1,380.52	2.00	0.00	2.00
11,906.67	90.57	359.60	11,273.07	1,381.06	-882.32	1,387.19	2.00	0.00	2.00
Hold 359.60° Azm									
12,000.00	90.57	359.60	11,272.14	1,474.38	-882.98	1,480.51	0.00	0.00	0.00
12,100.00	90.57	359.60	11,271.15	1,574.37	-883.68	1,580.51	0.00	0.00	0.00
12,200.00	90.57	359.60	11,270.15	1,674.37	-884.38	1,680.50	0.00	0.00	0.00
12,300.00	90.57	359.60	11,269.15	1,774.36	-885.09	1,780.50	0.00	0.00	0.00
12,400.00	90.57	359.60	11,268.16	1,874.35	-885.79	1,880.49	0.00	0.00	0.00
12,500.00	90.57	359.60	11,267.16	1,974.34	-886.49	1,980.49	0.00	0.00	0.00
12,600.00	90.57	359.60	11,266.16	2,074.34	-887.20	2,080.48	0.00	0.00	0.00
12,700.00	90.57	359.60	11,265.16	2,174.33	-887.90	2,180.48	0.00	0.00	0.00
12,800.00	90.57	359.60	11,264.17	2,274.32	-888.60	2,280.47	0.00	0.00	0.00
12,900.00	90.57	359.60	11,263.17	2,374.31	-889.31	2,380.47	0.00	0.00	0.00
13,000.00	90.57	359.60	11,262.17	2,474.31	-890.01	2,480.46	0.00	0.00	0.00
13,100.00	90.57	359.60	11,261.18	2,574.30	-890.71	2,580.46	0.00	0.00	0.00
13,167.90	90.57	359.60	11,260.50	2,642.19	-891.19	2,648.35	0.00	0.00	0.00
Begin 2.00°/100' Build									
13,182.41	90.86	359.60	11,260.32	2,656.71	-891.29	2,662.86	2.00	2.00	0.05
Hold 90.86° Inc									
13,200.00	90.86	359.60	11,260.05	2,674.29	-891.41	2,680.45	0.00	0.00	0.00
13,300.00	90.86	359.60	11,258.55	2,774.28	-892.10	2,780.44	0.00	0.00	0.00
13,400.00	90.86	359.60	11,257.05	2,874.26	-892.79	2,880.43	0.00	0.00	0.00
13,500.00	90.86	359.60	11,255.54	2,974.25	-893.48	2,980.42	0.00	0.00	0.00
13,600.00	90.86	359.60	11,254.04	3,074.24	-894.17	3,080.40	0.00	0.00	0.00
13,700.00	90.86	359.60	11,252.54	3,174.22	-894.86	3,180.39	0.00	0.00	0.00
13,800.00	90.86	359.60	11,251.03	3,274.21	-895.55	3,280.38	0.00	0.00	0.00
13,900.00	90.86	359.60	11,249.53	3,374.20	-896.24	3,380.37	0.00	0.00	0.00
14,000.00	90.86	359.60	11,248.03	3,474.18	-896.93	3,480.36	0.00	0.00	0.00
14,100.00	90.86	359.60	11,246.52	3,574.17	-897.62	3,580.35	0.00	0.00	0.00
14,168.00	90.86	359.60	11,245.50	3,642.16	-898.09	3,648.34	0.00	0.00	0.00
Begin 2.00°/100' Build									
14,196.95	91.44	359.60	11,244.92	3,671.10	-898.29	3,677.28	2.00	2.00	0.00
Hold 91.44° Inc									
14,200.00	91.44	359.60	11,244.84	3,674.15	-898.31	3,680.33	0.00	0.00	0.00
14,300.00	91.44	359.60	11,242.33	3,774.12	-899.00	3,780.30	0.00	0.00	0.00
14,400.00	91.44	359.60	11,239.81	3,874.08	-899.69	3,880.27	0.00	0.00	0.00
14,500.00	91.44	359.60	11,237.30	3,974.05	-900.38	3,980.24	0.00	0.00	0.00
14,600.00	91.44	359.60	11,234.79	4,074.01	-901.07	4,080.21	0.00	0.00	0.00
14,700.00	91.44	359.60	11,232.27	4,173.98	-901.76	4,180.17	0.00	0.00	0.00
14,800.00	91.44	359.60	11,229.76	4,273.95	-902.45	4,280.14	0.00	0.00	0.00
14,900.00	91.44	359.60	11,227.25	4,373.91	-903.14	4,380.11	0.00	0.00	0.00
15,000.00	91.44	359.60	11,224.73	4,473.88	-903.83	4,480.08	0.00	0.00	0.00
15,100.00	91.44	359.60	11,222.22	4,573.85	-904.52	4,580.05	0.00	0.00	0.00
15,168.32	91.44	359.60	11,220.50	4,642.14	-904.99	4,648.34	0.00	0.00	0.00
Begin 2.00°/100' Drop									



Phoenix Technology Services

Planning Report



Database:	USAEDMDB	Local Co-ordinate Reference:	Well Topaz 21602 30 Fed Com 3H
Company:	BTA Oil Producers, LLC	TVD Reference:	RKB @ 3715.50usft (Citadel 4)
Project:	Lea County, NM (NAD83 NME)	MD Reference:	RKB @ 3715.50usft (Citadel 4)
Site:	Topaz 21602 30 Fed Com	North Reference:	Grid
Well:	Topaz 21602 30 Fed Com 3H	Survey Calculation Method:	Minimum Curvature
Wellbore:	OH		
Design:	Plan 1 12-23-25		

Planned Survey										
Measured Depth (usft)	Inclination (°)	Azimuth (°)	Vertical Depth (usft)	+N/-S (usft)	+E/-W (usft)	Vertical Section (usft)	Dogleg Rate (°/100usft)	Build Rate (°/100usft)	Turn Rate (°/100usft)	
15,173.24	91.34	359.60	11,220.38	4,647.06	-905.02	4,653.27	2.00	-2.00	0.00	
Hold 91.34° Inc										
15,200.00	91.34	359.60	11,219.75	4,673.81	-905.21	4,680.02	0.00	0.00	0.00	
15,300.00	91.34	359.60	11,217.41	4,773.78	-905.89	4,779.99	0.00	0.00	0.00	
15,400.00	91.34	359.60	11,215.07	4,873.75	-906.58	4,879.96	0.00	0.00	0.00	
15,500.00	91.34	359.60	11,212.73	4,973.72	-907.27	4,979.94	0.00	0.00	0.00	
15,595.14	91.34	359.60	11,210.50	5,068.83	-907.93	5,075.05	0.00	0.00	0.00	
Begin 8.74°/100' Build & Turn										
15,600.00	91.36	0.03	11,210.39	5,073.69	-907.95	5,079.91	8.74	0.29	8.74	
15,700.00	91.63	8.77	11,207.77	5,173.27	-900.28	5,179.43	8.74	0.28	8.74	
15,800.00	91.87	17.51	11,204.71	5,270.51	-877.58	5,276.51	8.74	0.24	8.74	
15,900.00	92.07	26.26	11,201.27	5,363.16	-840.36	5,368.89	8.74	0.19	8.75	
16,000.00	92.21	35.01	11,197.53	5,449.06	-789.50	5,454.44	8.74	0.15	8.75	
16,051.89	92.27	39.54	11,195.50	5,490.31	-758.10	5,495.47	8.74	0.11	8.75	
Begin 8.87°/100' Drop & Turn										
16,100.00	92.09	43.81	11,193.67	5,526.21	-726.14	5,531.14	8.87	-0.38	8.87	
16,200.00	91.67	52.68	11,190.39	5,592.70	-651.66	5,597.11	8.87	-0.42	8.86	
16,300.00	91.21	61.54	11,187.87	5,646.94	-567.80	5,650.76	8.87	-0.46	8.86	
16,400.00	90.73	70.39	11,186.18	5,687.62	-476.58	5,690.81	8.87	-0.49	8.86	
16,500.00	90.22	79.25	11,185.34	5,713.78	-380.17	5,716.29	8.87	-0.50	8.86	
16,600.00	89.72	88.10	11,185.39	5,724.78	-280.87	5,726.60	8.87	-0.51	8.85	
16,618.44	89.62	89.74	11,185.50	5,725.13	-262.44	5,726.82	8.87	-0.51	8.86	
Begin 8.77°/100' Drop & Turn										
16,700.00	89.57	96.89	11,186.07	5,720.42	-181.07	5,721.54	8.77	-0.06	8.77	
16,800.00	89.52	105.66	11,186.87	5,700.89	-83.10	5,701.33	8.77	-0.05	8.77	
16,900.00	89.47	114.43	11,187.75	5,666.65	10.75	5,666.43	8.77	-0.04	8.77	
17,000.00	89.44	123.20	11,188.70	5,618.50	98.28	5,617.67	8.77	-0.03	8.77	
17,100.00	89.43	131.97	11,189.69	5,557.56	177.44	5,556.19	8.77	-0.02	8.77	
17,180.82	89.42	139.06	11,190.50	5,499.94	234.03	5,498.17	8.77	-0.01	8.77	
Begin 8.87°/100' Drop & Turn										
17,200.00	89.36	140.76	11,190.70	5,485.27	246.38	5,483.41	8.87	-0.33	8.87	
17,300.00	89.04	149.63	11,192.10	5,403.25	303.40	5,401.00	8.87	-0.32	8.87	
17,400.00	88.75	158.50	11,194.04	5,313.43	347.09	5,310.88	8.87	-0.30	8.87	
17,500.00	88.48	167.36	11,196.47	5,217.96	376.40	5,215.20	8.87	-0.27	8.87	
17,600.00	88.25	176.24	11,199.32	5,119.12	390.65	5,116.27	8.87	-0.23	8.87	
17,637.72	88.18	179.58	11,200.50	5,081.45	392.02	5,078.59	8.87	-0.20	8.87	
Begin 2.00°/100' Drop & Turn										
17,657.56	88.57	179.60	11,201.06	5,061.62	392.16	5,058.76	2.00	2.00	0.11	
Hold 88.57° Inc at 179.60° Azm										
17,700.00	88.57	179.60	11,202.12	5,019.19	392.45	5,016.33	0.00	0.00	0.00	
17,800.00	88.57	179.60	11,204.61	4,919.22	393.14	4,916.36	0.00	0.00	0.00	
17,900.00	88.57	179.60	11,207.11	4,819.26	393.83	4,816.39	0.00	0.00	0.00	
18,000.00	88.57	179.60	11,209.60	4,719.29	394.52	4,716.42	0.00	0.00	0.00	
18,100.00	88.57	179.60	11,212.09	4,619.32	395.21	4,616.45	0.00	0.00	0.00	
18,200.00	88.57	179.60	11,214.58	4,519.36	395.90	4,516.48	0.00	0.00	0.00	
18,300.00	88.57	179.60	11,217.08	4,419.39	396.59	4,416.51	0.00	0.00	0.00	
18,400.00	88.57	179.60	11,219.57	4,319.42	397.28	4,316.55	0.00	0.00	0.00	
18,500.00	88.57	179.60	11,222.06	4,219.46	397.97	4,216.58	0.00	0.00	0.00	
18,600.00	88.57	179.60	11,224.55	4,119.49	398.66	4,116.61	0.00	0.00	0.00	
18,638.03	88.57	179.60	11,225.50	4,081.47	398.92	4,078.59	0.00	0.00	0.00	
Begin 2.00°/100' Build										
18,652.26	88.86	179.60	11,225.82	4,067.25	399.02	4,064.37	2.00	2.00	0.00	
Hold 88.86° Inc										



Phoenix Technology Services

Planning Report



Database:	USAEDMDB	Local Co-ordinate Reference:	Well Topaz 21602 30 Fed Com 3H
Company:	BTA Oil Producers, LLC	TVD Reference:	RKB @ 3715.50usft (Citadel 4)
Project:	Lea County, NM (NAD83 NME)	MD Reference:	RKB @ 3715.50usft (Citadel 4)
Site:	Topaz 21602 30 Fed Com	North Reference:	Grid
Well:	Topaz 21602 30 Fed Com 3H	Survey Calculation Method:	Minimum Curvature
Wellbore:	OH		
Design:	Plan 1 12-23-25		

Planned Survey										
Measured Depth (usft)	Inclination (°)	Azimuth (°)	Vertical Depth (usft)	+N/-S (usft)	+E/-W (usft)	Vertical Section (usft)	Dogleg Rate (°/100usft)	Build Rate (°/100usft)	Turn Rate (°/100usft)	
18,700.00	88.86	179.60	11,226.77	4,019.52	399.35	4,016.63	0.00	0.00	0.00	
18,800.00	88.86	179.60	11,228.77	3,919.54	400.04	3,916.65	0.00	0.00	0.00	
18,900.00	88.86	179.60	11,230.76	3,819.56	400.73	3,816.67	0.00	0.00	0.00	
19,000.00	88.86	179.60	11,232.76	3,719.59	401.42	3,716.69	0.00	0.00	0.00	
19,100.00	88.86	179.60	11,234.76	3,619.61	402.11	3,616.71	0.00	0.00	0.00	
19,200.00	88.86	179.60	11,236.75	3,519.63	402.80	3,516.73	0.00	0.00	0.00	
19,300.00	88.86	179.60	11,238.75	3,419.65	403.49	3,416.75	0.00	0.00	0.00	
19,400.00	88.86	179.60	11,240.75	3,319.68	404.18	3,316.77	0.00	0.00	0.00	
19,500.00	88.86	179.60	11,242.74	3,219.70	404.87	3,216.79	0.00	0.00	0.00	
19,600.00	88.86	179.60	11,244.74	3,119.72	405.56	3,116.81	0.00	0.00	0.00	
19,638.23	88.86	179.60	11,245.50	3,081.50	405.82	3,078.59	0.00	0.00	0.00	
Begin 2.00°/100' Build										
19,667.19	89.44	179.60	11,245.93	3,052.54	406.02	3,049.64	2.00	2.00	0.00	
Hold 89.44° Inc										
19,700.00	89.44	179.60	11,246.26	3,019.73	406.25	3,016.82	0.00	0.00	0.00	
19,800.00	89.44	179.60	11,247.24	2,919.74	406.94	2,916.83	0.00	0.00	0.00	
19,900.00	89.44	179.60	11,248.23	2,819.75	407.62	2,816.83	0.00	0.00	0.00	
20,000.00	89.44	179.60	11,249.21	2,719.76	408.31	2,716.84	0.00	0.00	0.00	
20,100.00	89.44	179.60	11,250.20	2,619.76	409.00	2,616.84	0.00	0.00	0.00	
20,200.00	89.44	179.60	11,251.18	2,519.77	409.69	2,516.85	0.00	0.00	0.00	
20,300.00	89.44	179.60	11,252.17	2,419.78	410.38	2,416.85	0.00	0.00	0.00	
20,400.00	89.44	179.60	11,253.15	2,319.79	411.07	2,316.86	0.00	0.00	0.00	
20,500.00	89.44	179.60	11,254.14	2,219.79	411.76	2,216.86	0.00	0.00	0.00	
20,600.00	89.44	179.60	11,255.12	2,119.80	412.45	2,116.87	0.00	0.00	0.00	
20,638.28	89.44	179.60	11,255.50	2,081.52	412.71	2,078.59	0.00	0.00	0.00	
Begin 2.00°/100' Drop										
20,638.70	89.43	179.60	11,255.50	2,081.10	412.72	2,078.17	1.99	-1.99	0.00	
Hold 89.43° Inc										
20,700.00	89.43	179.60	11,256.12	2,019.81	413.14	2,016.87	0.00	0.00	0.00	
20,800.00	89.43	179.60	11,257.12	1,919.81	413.83	1,916.88	0.00	0.00	0.00	
20,900.00	89.43	179.60	11,258.12	1,819.82	414.52	1,816.88	0.00	0.00	0.00	
21,000.00	89.43	179.60	11,259.12	1,719.83	415.21	1,716.89	0.00	0.00	0.00	
21,100.00	89.43	179.60	11,260.12	1,619.84	415.90	1,616.89	0.00	0.00	0.00	
21,200.00	89.43	179.60	11,261.12	1,519.84	416.59	1,516.90	0.00	0.00	0.00	
21,300.00	89.43	179.60	11,262.12	1,419.85	417.28	1,416.90	0.00	0.00	0.00	
21,400.00	89.43	179.60	11,263.12	1,319.86	417.97	1,316.91	0.00	0.00	0.00	
21,500.00	89.43	179.60	11,264.12	1,219.87	418.66	1,216.91	0.00	0.00	0.00	
21,600.00	89.43	179.60	11,265.12	1,119.87	419.35	1,116.92	0.00	0.00	0.00	
21,638.33	89.43	179.60	11,265.50	1,081.55	419.61	1,078.59	0.00	0.00	0.00	
Begin 2.00°/100' Build										
21,667.89	90.02	179.60	11,265.64	1,051.99	419.81	1,049.03	2.00	2.00	0.00	
Hold 90.02° Inc										
21,700.00	90.02	179.60	11,265.63	1,019.88	420.04	1,016.92	0.00	0.00	0.00	
21,800.00	90.02	179.60	11,265.60	919.88	420.73	916.92	0.00	0.00	0.00	
21,900.00	90.02	179.60	11,265.57	819.88	421.42	816.92	0.00	0.00	0.00	
22,000.00	90.02	179.60	11,265.54	719.89	422.11	716.92	0.00	0.00	0.00	
22,100.00	90.02	179.60	11,265.51	619.89	422.80	616.92	0.00	0.00	0.00	
22,115.19	90.02	179.60	11,265.50	604.70	422.90	601.73	0.00	0.00	0.00	
TD at 22115.19										



Phoenix Technology Services
Planning Report



Database:	USAEDMDB	Local Co-ordinate Reference:	Well Topaz 21602 30 Fed Com 3H
Company:	BTA Oil Producers, LLC	TVD Reference:	RKB @ 3715.50usft (Citadel 4)
Project:	Lea County, NM (NAD83 NME)	MD Reference:	RKB @ 3715.50usft (Citadel 4)
Site:	Topaz 21602 30 Fed Com	North Reference:	Grid
Well:	Topaz 21602 30 Fed Com 3H	Survey Calculation Method:	Minimum Curvature
Wellbore:	OH		
Design:	Plan 1 12-23-25		

Design Targets										
Target Name	- hit/miss target	Dip Angle	Dip Dir.	TVD	+N/-S	+E/-W	Northing	Easting	Latitude	Longitude
- Shape		(°)	(°)	(usft)	(usft)	(usft)	(usft)	(usft)		
KOP - T 21602 30 FC	- plan misses target center by 51.00usft at 10788.68usft MD (10702.30 TVD, 592.24 N, -826.05 E)	0.00	0.00	10,702.26	592.24	-877.05	559,851.24	765,158.58	32° 32' 13.169796 N	3° 36' 25.363643 W
- Point										
MT - T 21602 30 FC 3	- plan hits target center	0.00	0.00	11,185.50	5,725.13	-262.44	564,984.13	765,773.19	32° 33' 3.916989 N	3° 36' 17.774319 W
- Point										
NPZ2 - T 21602 30 FC	- plan hits target center	0.00	0.00	11,190.50	5,499.94	234.03	564,758.94	766,269.66	32° 33' 1.655150 N	3° 36' 11.992184 W
- Point										
NPZ1 - T 21602 30 FC	- plan hits target center	0.00	0.00	11,195.50	5,490.31	-758.10	564,749.31	765,277.53	32° 33' 1.627015 N	3° 36' 23.583755 W
- Point										
TP3 - T 21602 30 FC	- plan hits target center	0.00	0.00	11,200.50	5,081.45	392.02	564,340.45	766,427.65	32° 32' 57.503577 N	3° 36' 10.179969 W
- Point										
TP1 - T 21602 30 FC	- plan hits target center	0.00	0.00	11,210.50	5,068.83	-907.93	564,327.83	765,127.70	32° 32' 57.466689 N	3° 36' 25.367765 W
- Point										
PPP3 - T 21602 30 FC	- plan misses target center by 0.01usft at 18207.05usft MD (11214.76 TVD, 4512.31 N, 395.95 E)	0.00	0.00	11,214.76	4,512.31	395.94	563,771.31	766,431.57	32° 32' 51.871814 N	3° 36' 10.179784 W
- Point										
WP4 - T 21602 30 FC	- plan hits target center	0.00	0.00	11,220.50	4,642.14	-904.99	563,901.14	765,130.64	32° 32' 53.244497 N	3° 36' 25.367378 W
- Point										
PPP2 - T 21602 30 FC	- plan hits target center	0.00	0.00	11,224.08	4,499.69	-904.00	563,758.69	765,131.63	32° 32' 51.834922 N	3° 36' 25.367201 W
- Point										
WP5 - T 21602 30 FC	- plan hits target center	0.00	0.00	11,225.50	4,081.47	398.92	563,340.47	766,434.55	32° 32' 47.608558 N	3° 36' 10.179497 W
- Point										
WP3 - T 21602 30 FC	- plan hits target center	0.00	0.00	11,245.50	3,642.16	-898.09	562,901.16	765,137.54	32° 32' 43.349469 N	3° 36' 25.366465 W
- Point										
WP6 - T 21602 30 FC	- plan hits target center	0.00	0.00	11,245.50	3,081.50	405.82	562,340.50	766,441.45	32° 32' 37.713633 N	3° 36' 10.179019 W
- Point										
WP7 - T 21602 30 FC	- plan hits target center	0.00	0.00	11,255.50	2,081.52	412.72	561,340.52	766,448.34	32° 32' 27.818606 N	3° 36' 10.178594 W
- Point										
WP2 - T 21602 30 FC	- plan hits target center	0.00	0.00	11,260.50	2,642.19	-891.19	561,901.19	765,144.44	32° 32' 33.454536 N	3° 36' 25.365546 W
- Point										
WP8 - T 21602 30 FC	- plan hits target center	0.00	0.00	11,265.50	1,081.55	419.61	560,340.55	766,455.24	32° 32' 17.923673 N	3° 36' 10.178162 W
- Point										
BHL - T 21602 30 FC	- plan hits target center	0.00	0.00	11,265.50	604.70	422.90	559,863.70	766,458.53	32° 32' 13.205131 N	3° 36' 10.177931 W
- Point										
LTP - T 21602 30 FC :	- plan misses target center by 0.35usft at 22065.19usft MD (11265.52 TVD, 654.70 N, 422.56 E)	0.00	0.00	11,265.87	654.70	422.55	559,913.70	766,458.18	32° 32' 13.699893 N	3° 36' 10.178014 W
- Point										



Phoenix Technology Services
Planning Report



Database:	USAEDMDB	Local Co-ordinate Reference:	Well Topaz 21602 30 Fed Com 3H
Company:	BTA Oil Producers, LLC	TVD Reference:	RKB @ 3715.50usft (Citadel 4)
Project:	Lea County, NM (NAD83 NME)	MD Reference:	RKB @ 3715.50usft (Citadel 4)
Site:	Topaz 21602 30 Fed Com	North Reference:	Grid
Well:	Topaz 21602 30 Fed Com 3H	Survey Calculation Method:	Minimum Curvature
Wellbore:	OH		
Design:	Plan 1 12-23-25		

WP1 - T 21602 30 FC 0.00 0.00 11,270.50 1,642.21 -884.29 560,901.21 765,151.34 i2° 32' 23.559500 N 3° 36' 25.364588 W
 - plan misses target center by 0.14usft at 12167.84usft MD (11270.47 TVD, 1642.21 N, -884.16 E)
 - Point

FTP/PPP1 - T 21602 : 0.00 0.00 11,280.50 642.24 -877.39 559,901.24 765,158.24 i2° 32' 13.664558 N 3° 36' 25.363633 W
 - plan misses target center by 209.54usft at 11276.56usft MD (11133.31 TVD, 787.09 N, -841.90 E)
 - Point

Formations

Measured Depth (usft)	Vertical Depth (usft)	Name	Lithology	Dip (°)	Dip Direction (°)
1,535.50	1,535.50	RUSTLER			
2,316.03	2,315.50	TOP SALT			
2,924.18	2,915.50	BASE SALT			
5,807.99	5,755.50	DELAWARE			
5,939.99	5,885.50	BELL CANYON			
6,239.54	6,180.50	CHERRY CANYON			
6,579.71	6,515.50	BRUSHY CANYON			
8,761.88	8,675.50	BONE SPRING LIME			
9,766.88	9,680.50	FIRST BONE SPRING SAND			
10,281.88	10,195.50	SECOND BONE SPRING SAND			
10,766.88	10,680.50	TARGET BASE_SHALE MARKER			
10,826.91	10,740.50	THIRD BONE SPRING CARBONAT			
11,162.94	11,050.50	THIRD BONE SPRING SAND			

Plan Annotations

Measured Depth (usft)	Vertical Depth (usft)	Local Coordinates		Comment
		+N/-S (usft)	+E/-W (usft)	
2,020.00	2,020.00	0.00	0.00	KOP, Begin 2.00°/100' Build
2,520.00	2,517.47	25.36	-35.37	Hold 10.00° Inc at 305.64° Azm
7,872.05	7,788.20	566.88	-790.68	Begin 2.00°/100' Drop
8,372.05	8,285.67	592.24	-826.05	Begin Vertical Hold
10,788.64	10,702.26	592.24	-826.05	KOP2, Begin 10.00°/100' Build
11,694.34	11,275.19	1,168.99	-872.96	LP, Hold 90.57° Inc, Begin 2.00°/100' Turn
11,906.67	11,273.07	1,381.06	-882.32	Hold 359.60° Azm
13,167.90	11,260.50	2,642.19	-891.19	Begin 2.00°/100' Build
13,182.41	11,260.32	2,656.71	-891.29	Hold 90.86° Inc
14,168.00	11,245.50	3,642.16	-898.09	Begin 2.00°/100' Build
14,196.95	11,244.92	3,671.10	-898.29	Hold 91.44° Inc
15,168.32	11,220.50	4,642.14	-904.99	Begin 2.00°/100' Drop
15,173.24	11,220.38	4,647.06	-905.02	Hold 91.34° Inc
15,595.14	11,210.50	5,068.83	-907.93	Begin 8.74°/100' Build & Turn
16,051.89	11,195.50	5,490.31	-758.10	Begin 8.87°/100' Drop & Turn
16,618.44	11,185.50	5,725.13	-262.44	Begin 8.77°/100' Drop & Turn
17,180.82	11,190.50	5,499.94	234.03	Begin 8.87°/100' Drop & Turn
17,637.72	11,200.50	5,081.45	392.02	Begin 2.00°/100' Drop & Turn
17,657.56	11,201.06	5,061.62	392.16	Hold 88.57° Inc at 179.60° Azm
18,638.03	11,225.50	4,081.47	398.92	Begin 2.00°/100' Build
18,652.26	11,225.82	4,067.25	399.02	Hold 88.86° Inc
19,638.23	11,245.50	3,081.50	405.82	Begin 2.00°/100' Build
19,667.19	11,245.93	3,052.54	406.02	Hold 89.44° Inc
20,638.28	11,255.50	2,081.52	412.71	Begin 2.00°/100' Drop
20,638.70	11,255.50	2,081.10	412.72	Hold 89.43° Inc
21,638.33	11,265.50	1,081.55	419.61	Begin 2.00°/100' Build
21,667.89	11,265.64	1,051.99	419.81	Hold 90.02° Inc
22,115.19	11,265.50	604.70	422.90	TD at 22115.19

WELL DETAILS						
+N-S	+E-W	Northing	Ground Level	3692.00	Latitude	Longitude
0.00	0.00	559259.00	Easting	766035.63	32° 32' 7.250432 N	103° 36' 15.166172 W

SECTION DETAILS									
MD	Inc	Azi	TVD	+N-S	+E-W	Vsect	Departure	Annotation	
2020.00	0.00	0.00	2020.00	0.00	0.00	0.00	0.00	KOP, Begin 2.00°/100' Build	
2520.00	10.00	305.64	2517.47	25.36	-35.37	25.61	43.52	Hold 10.00° Inc at 305.64° Azm	
7872.05	10.00	305.64	7788.20	566.88	-790.68	572.39	972.90	Begin 2.00°/100' Drop	
8372.05	0.00	0.00	8285.67	592.24	-826.05	597.99	1016.42	Begin Vertical Hold	
10788.64	0.00	0.00	10702.26	592.24	-826.05	597.99	1016.42	KOP2, Begin 10.00°/100' Build	
11694.34	90.57	355.35	11275.19	1168.99	-872.96	1175.06	1595.08	LP, Hold 90.57° Inc, Begin 2.00°/100' Turn	
11906.67	90.57	359.60	11273.07	1381.06	-882.32	1387.19	1807.40	Hold 359.60° Azm	
13167.90	90.57	359.60	11260.50	2642.19	-891.19	2648.35	3068.56	Begin 2.00°/100' Build	
13182.41	90.86	359.60	11260.32	2656.71	-891.29	2662.86	3083.08	Hold 90.86° Inc	
14168.00	90.86	359.60	11245.50	3642.16	-898.09	3648.34	4068.55	Begin 2.00°/100' Build	
14196.95	91.44	359.60	11244.92	3671.10	-898.29	3677.28	4097.50	Hold 91.44° Inc	
15168.32	91.44	359.60	11220.50	4642.14	-904.99	4648.34	5068.56	Begin 2.00°/100' Drop	
15173.24	91.34	359.60	11220.38	4647.06	-905.02	4653.27	5073.48	Hold 91.34° Inc	
15595.14	91.34	359.60	11210.50	5068.83	-907.93	5075.04	5495.26	Begin 8.74°/100' Build & Turn	
16051.89	92.27	39.54	11195.50	5490.31	-758.10	5495.47	5951.76	Begin 8.87°/100' Drop & Turn	
16618.44	89.62	89.74	11185.50	5725.13	-262.44	5726.82	6518.17	Begin 8.77°/100' Drop & Turn	
17180.82	89.42	139.06	11190.50	5499.94	234.03	5498.17	7080.53	Begin 8.87°/100' Drop & Turn	
17637.72	88.18	179.58	11200.50	5081.45	392.02	5078.59	7537.31	Begin 2.00°/100' Drop & Turn	
17657.55	88.57	179.60	11201.06	5061.62	392.16	5058.76	7557.14	Hold 88.57° Inc at 179.60° Azm	
18638.03	88.57	179.60	11225.50	4081.47	398.92	4078.59	8537.31	Begin 2.00°/100' Build	
18652.26	88.86	179.60	11225.82	4067.25	399.02	4064.37	8551.53	Hold 88.86° Inc	
19638.23	88.86	179.60	11245.50	3081.50	405.82	3078.59	9537.30	Begin 2.00°/100' Build	
19667.19	89.44	179.60	11245.93	3052.54	406.02	3049.64	9566.26	Hold 89.44° Inc	
20638.28	89.44	179.60	11255.50	2081.52	412.71	2078.59	10537.31	Begin 2.00°/100' Drop	
20638.70	89.43	179.60	11255.50	2081.10	412.72	2078.17	10537.31	Hold 89.43° Inc	
21638.33	89.43	179.60	11265.50	1081.55	419.61	1078.59	11537.31	Begin 2.00°/100' Build	
21667.89	90.02	179.60	11265.64	1051.99	419.81	1049.03	11566.87	Hold 90.02° Inc	
22115.19	90.02	179.60	11265.50	604.70	422.90	601.73	12014.16	TD at 22115.19	

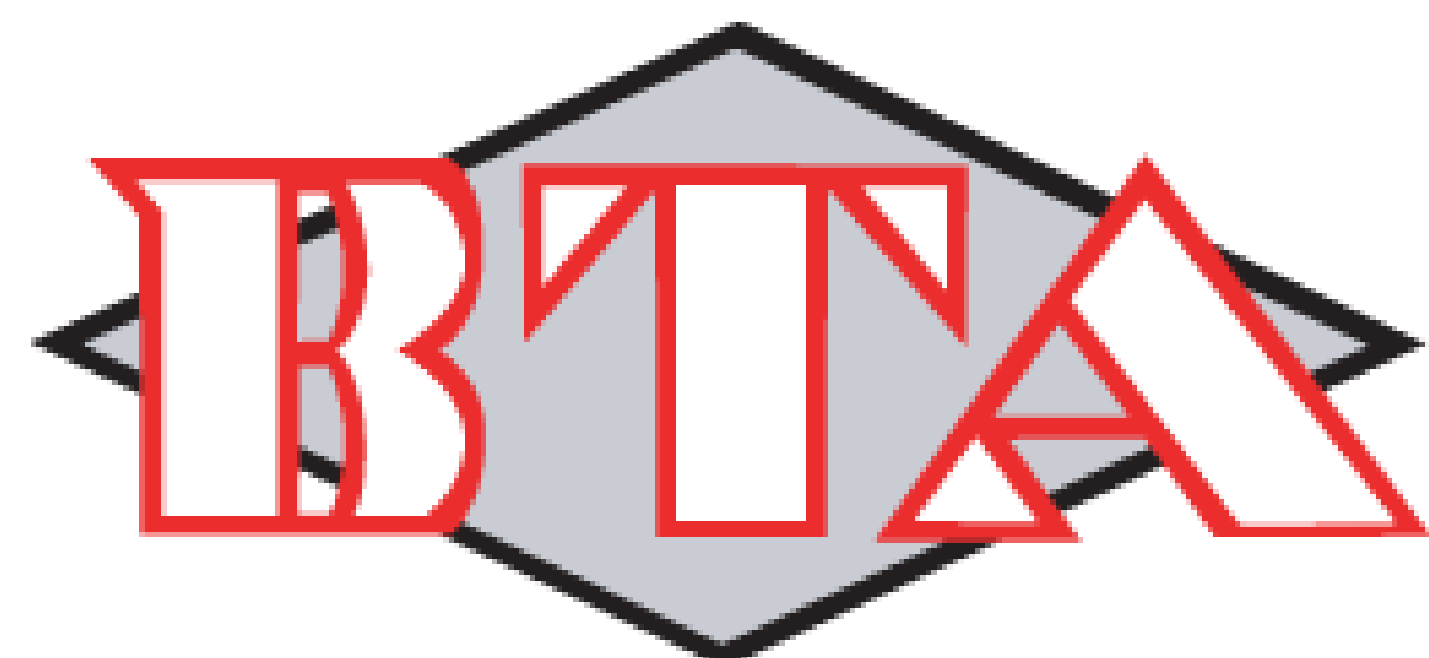

Project: Lea County, NM (NAD83 NME)
 Site: Topaz 21602 30 Fed Com
 Well: Topaz 21602 30 Fed Com 3H
 Wellbore: OH
 Design: Plan 1 12-23-25
 Rig: Citadel 4

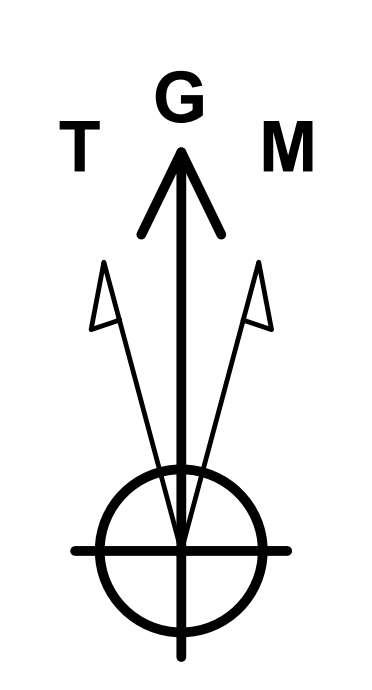

Azimuths to Grid North
 True North: -0.39°
 Magnetic North: 5.69°
 Magnetic Field
 Strength: 47379.0nT
 Dip Angle: 60.20°
 Date: 2/22/2026
 Model: HDGM



Map System: US State Plane 1983
 Datum: North American Datum 1983
 Ellipsoid: GRS 1980
 Zone Name: New Mexico Eastern Zone
 Local Origin: Well Topaz 21602 30 Fed Com 3H, Grid North
 Latitude: 32° 32' 7.250432 N
 Longitude: 103° 36' 15.166172 W
 Grid East: 766035.63
 Grid North: 559259.00
 Scale Factor: 1.000
 Geomagnetic Model: HDGM
 Sample Date: 22-Feb-26
 Magnetic Declination: 6.083°
 Dip Angle from Horizontal: 60.200°
 Magnetic Field Strength: 47379.0000000nT
 To convert a Magnetic Direction to a Grid Direction, Add 5.691°
 To convert a Magnetic Direction to a True Direction, Add 6.083° East
 To convert a True Direction to a Grid Direction, Subtract 0.392°

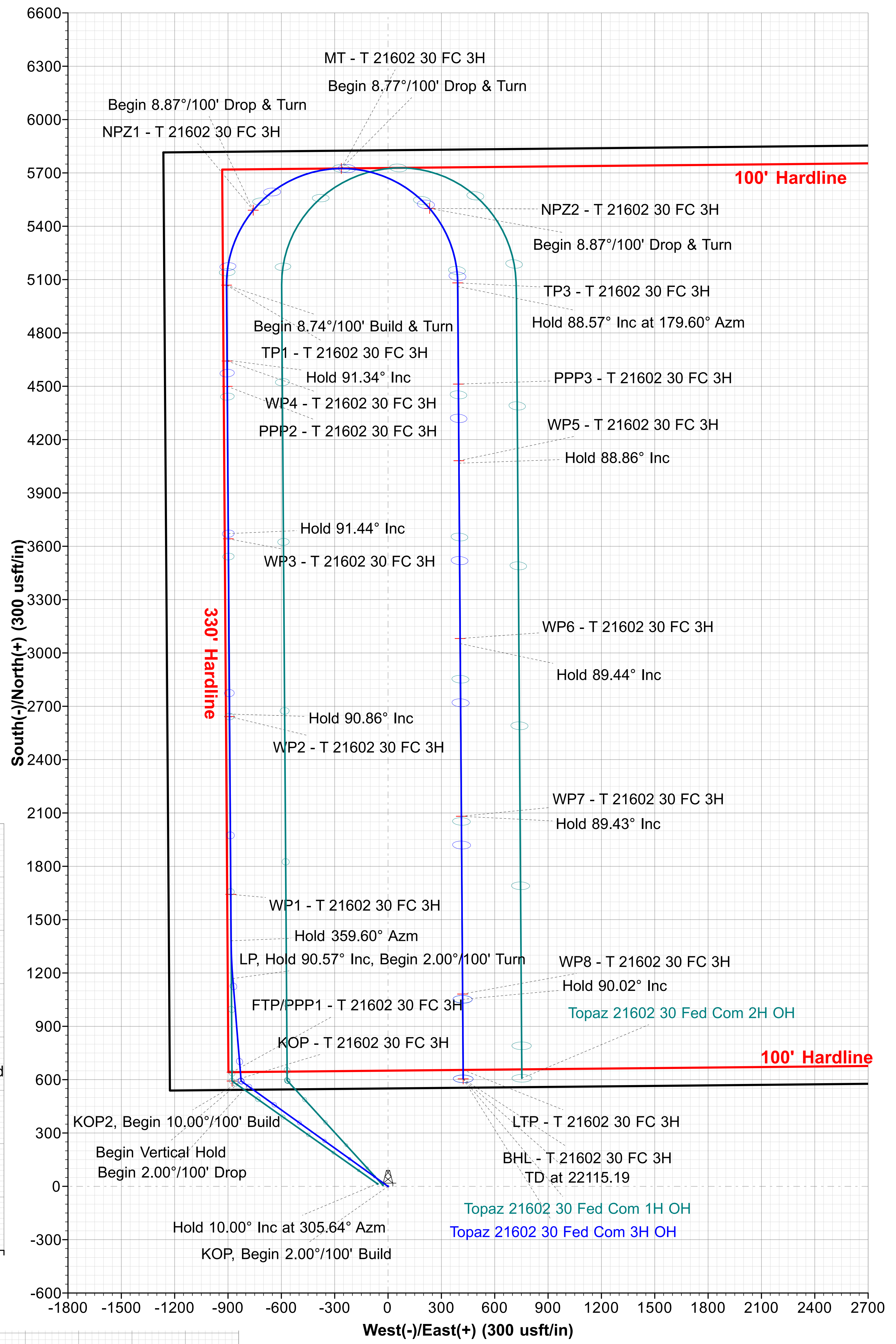
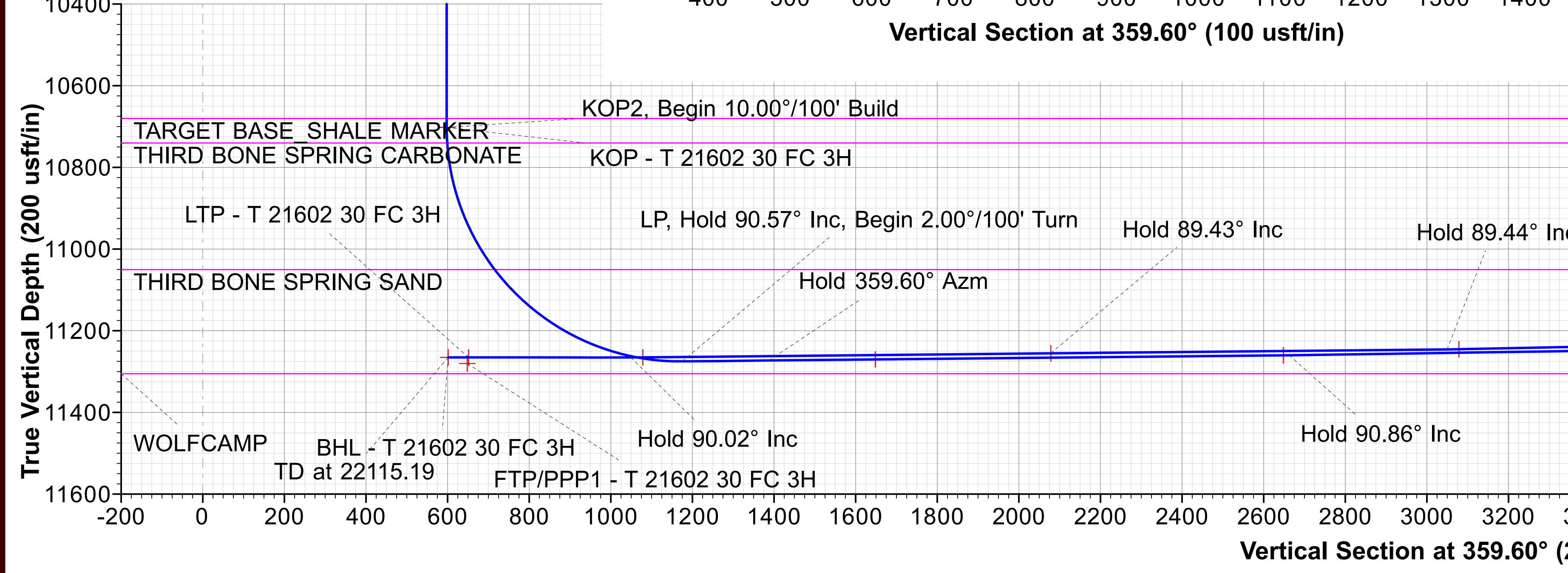
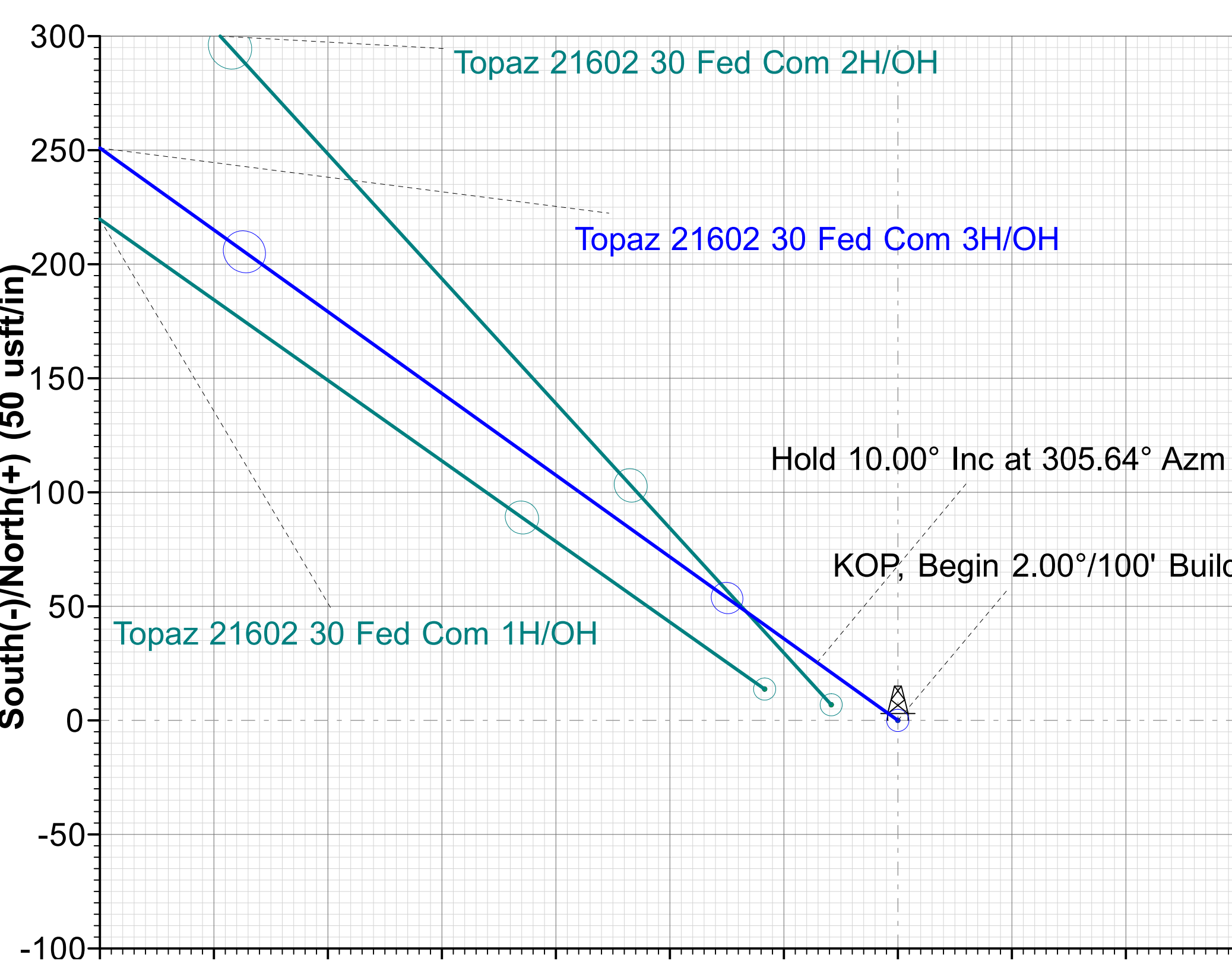
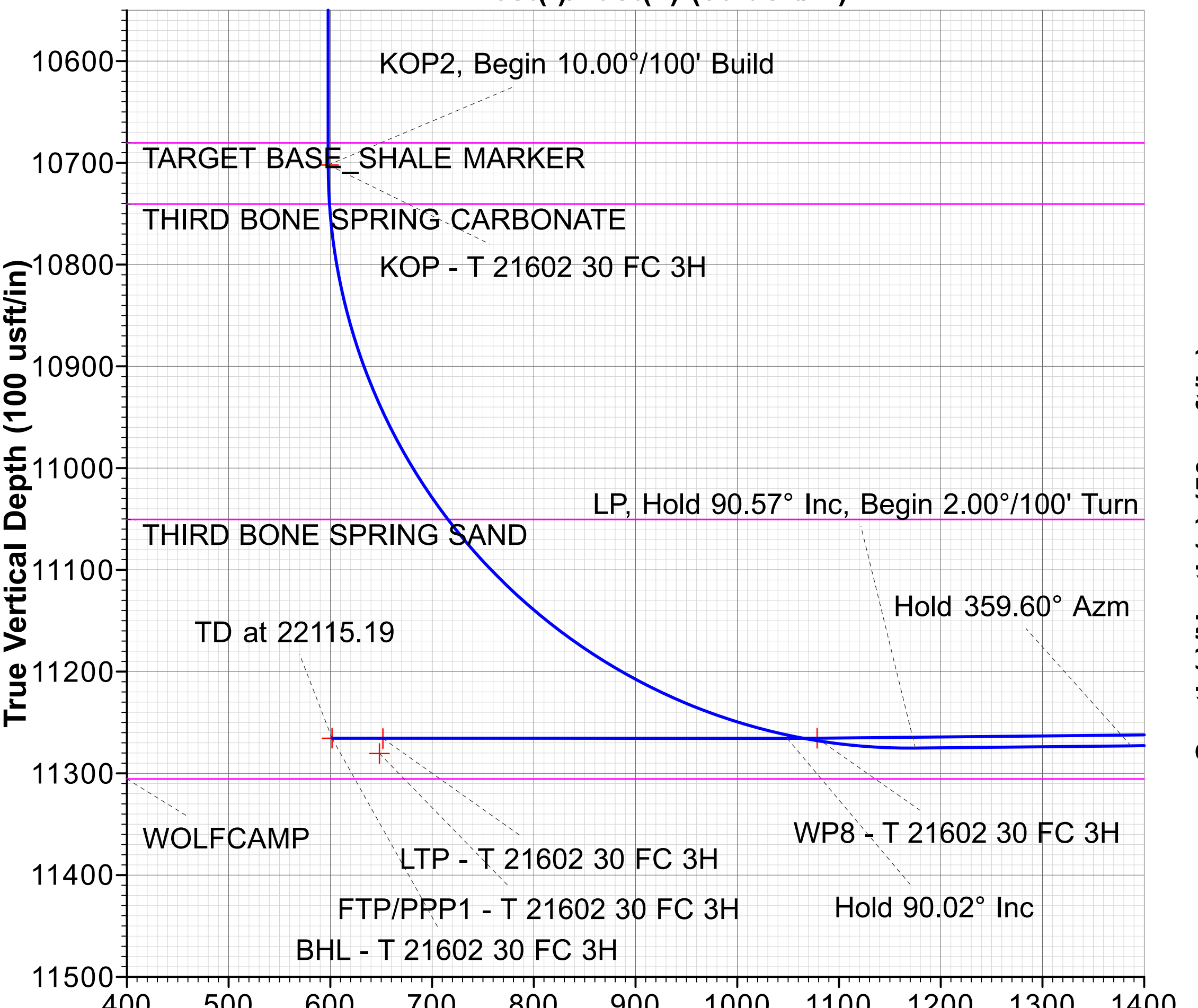
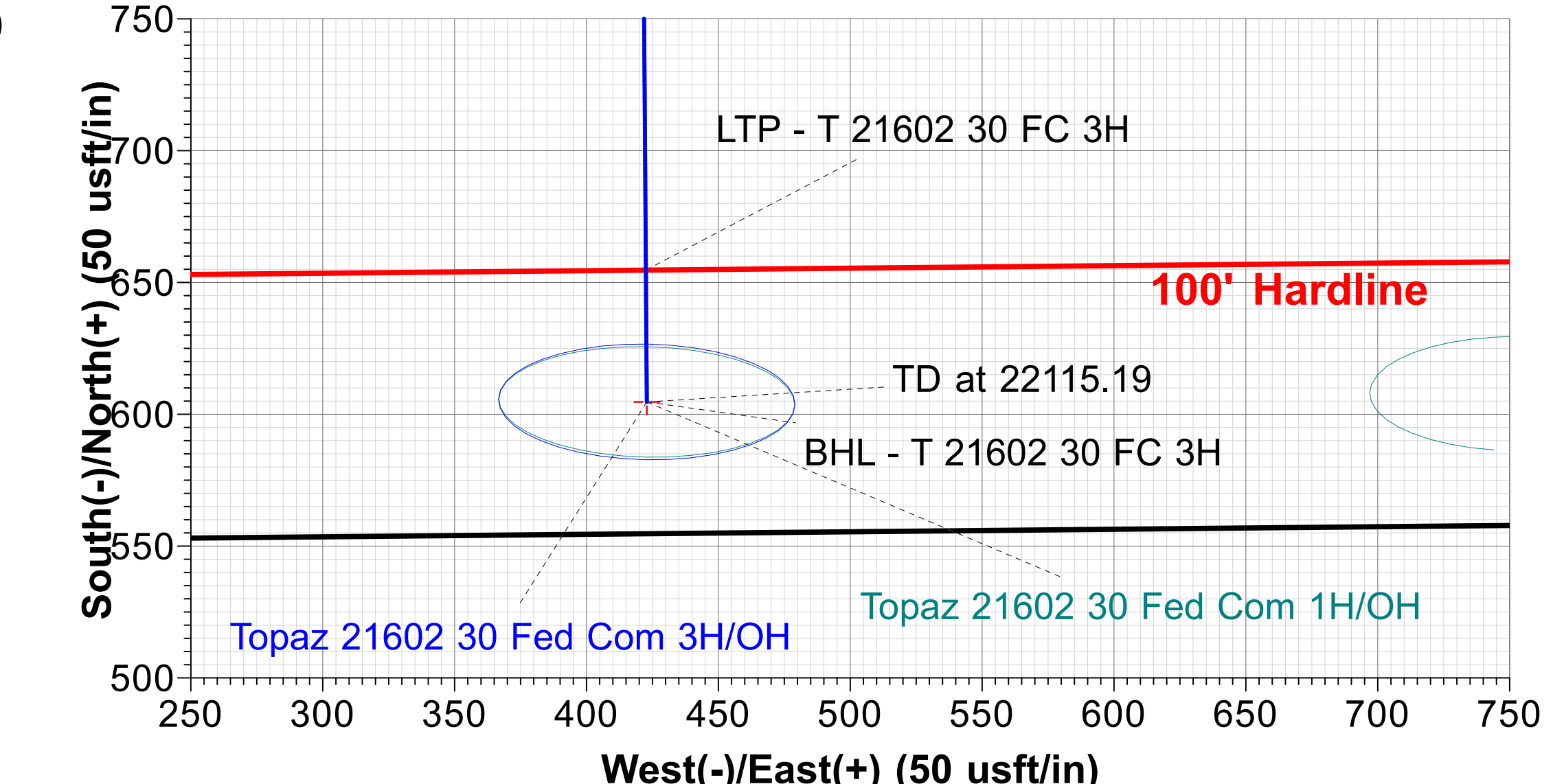
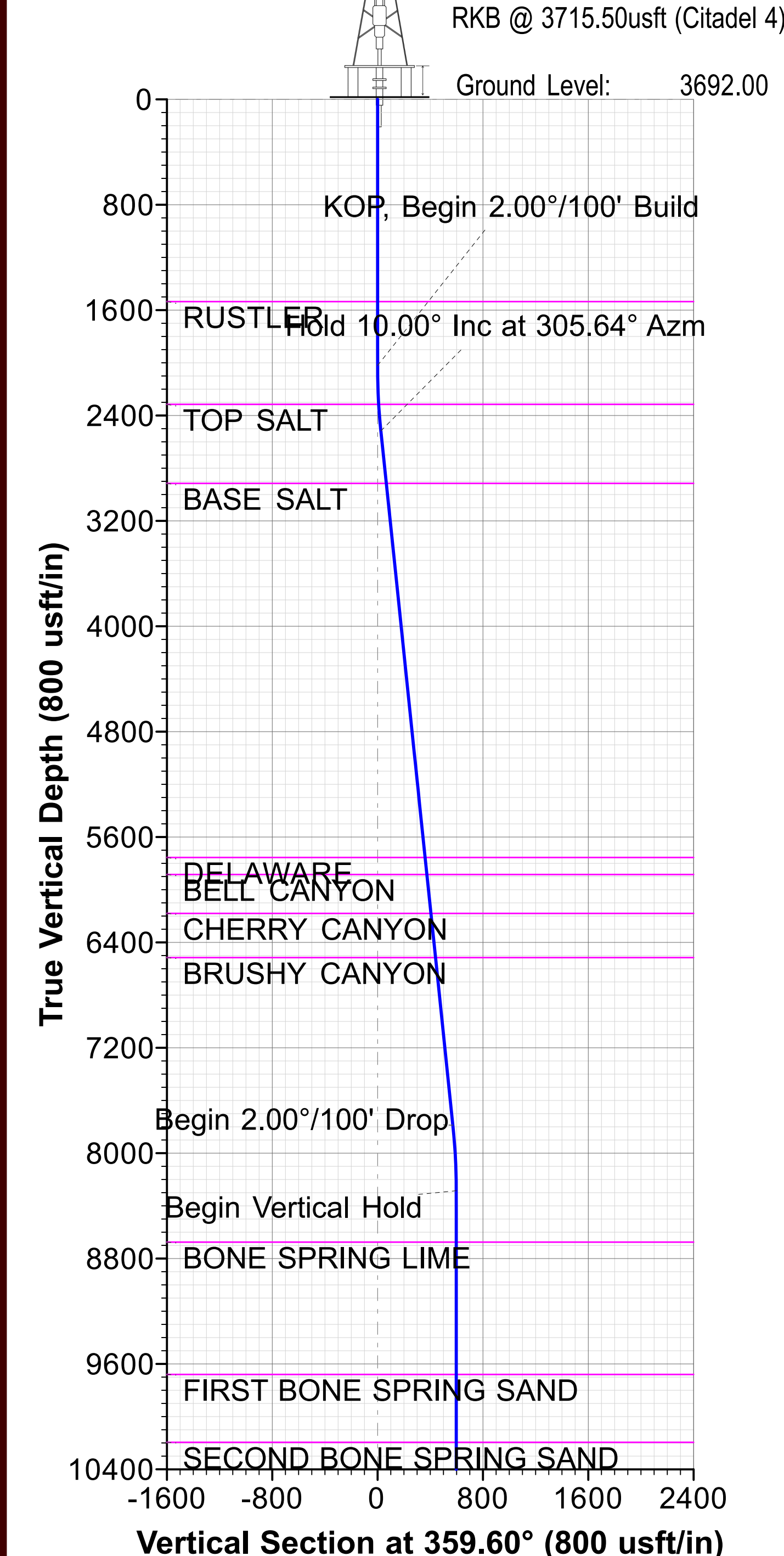

Form 3160-5
(October 2024)

UNITED STATES
DEPARTMENT OF THE INTERIOR
BUREAU OF LAND MANAGEMENT

FORM APPROVED
OMB No. 1004-0220
Expires: October 31, 2027

SUNDRY NOTICES AND REPORTS ON WELLS
Do not use this form for proposals to drill or to re-enter an abandoned well. Use Form 3160-3 (APD) for such proposals.

5. Lease Serial No.	NMNM87274
6. If Indian, Allottee or Tribe Name	

SUBMIT IN TRIPLICATE - Other instructions on page 2		7. If Unit of CA/Agreement, Name and/or No.
1. Type of Well <input checked="" type="checkbox"/> Oil Well <input type="checkbox"/> Gas Well <input type="checkbox"/> Other		8. Well Name and No. TOPAZ FEDERAL COM/301H
2. Name of Operator BTA OIL PRODUCERS LLC		9. API Well No. 3002555821
3a. Address 104 S. Pecos, Midland, TX 79701	3b. Phone No. (include area code) (432) 682-3753	10. Field and Pool or Exploratory Area WC-025 G-08 S213304D/BONE SPRING
4. Location of Well (Footage, Sec., T.,R.,M., or Survey Description) SEC 31/T20S/R34E/NMP		11. Country or Parish, State LEA/NM

12. CHECK THE APPROPRIATE BOX(ES) TO INDICATE NATURE OF NOTICE, REPORT OR OTHER DATA

TYPE OF SUBMISSION	TYPE OF ACTION			
<input checked="" type="checkbox"/> Notice of Intent	<input type="checkbox"/> Acidize	<input type="checkbox"/> Deepen	<input type="checkbox"/> Production (Start/Resume)	<input type="checkbox"/> Water Shut-Off
<input type="checkbox"/> Subsequent Report	<input type="checkbox"/> Alter Casing	<input type="checkbox"/> Hydraulic Fracturing	<input type="checkbox"/> Reclamation	<input type="checkbox"/> Well Integrity
<input type="checkbox"/> Final Abandonment Notice	<input type="checkbox"/> Casing Repair	<input type="checkbox"/> New Construction	<input type="checkbox"/> Recomplete	<input type="checkbox"/> Other
	<input checked="" type="checkbox"/> Change Plans	<input type="checkbox"/> Plug and Abandon	<input type="checkbox"/> Temporarily Abandon	
	<input type="checkbox"/> Convert to Injection	<input type="checkbox"/> Plug Back	<input type="checkbox"/> Water Disposal	

13. Describe Proposed or Completed Operation: Clearly state all pertinent details, including estimated starting date of any proposed work and approximate duration thereof. If the proposal is to deepen directionally or recomplete horizontally, give subsurface locations and measured and true vertical depths of all pertinent markers and zones. Attach the Bond under which the work will be performed or provide the Bond No. on file with BLM/BIA. Required subsequent reports must be filed within 30 days following completion of the involved operations. If the operation results in a multiple completion or recompletion in a new interval, a Form 3160-4 must be filed once testing has been completed. Final Abandonment Notices must be filed only after all requirements, including reclamation, have been completed and the operator has determined that the site is ready for final inspection.)

BTA Oil Producers LLC respectfully requests the following footage, casing, cement, drill plan, assigned acreage and name changes to the original APD as approved. We are also requesting a variance for BOP break testing. Please see attached documents for more details.

APD ID 10400081220
From: TOPAZ FEDERAL COM 301H
To: TOPAZ 21602 30 FED COM 3H

From: 640.56 acres
To: 320.56 acres

****Please see New Footages on attached pdf****

14. I hereby certify that the foregoing is true and correct. Name (Printed/Typed) LIZ VELASCO / Ph: (432) 682-3753	Title Regulatory Analyst
Signature (Electronic Submission)	Date 03/03/2026

THE SPACE FOR FEDERAL OR STATE OFFICE USE

Approved by CHRISTOPHER WALLS / Ph: (575) 234-2234 / Approved	Title Petroleum Engineer	Date 03/20/2026
Conditions of approval, if any, are attached. Approval of this notice does not warrant or certify that the applicant holds legal or equitable title to those rights in the subject lease which would entitle the applicant to conduct operations thereon.	Office CARLSBAD	

Title 18 U.S.C Section 1001 and Title 43 U.S.C Section 1212, make it a crime for any person knowingly and willfully to make to any department or agency of the United States any false, fictitious or fraudulent statements or representations as to any matter within its jurisdiction.

(Instructions on page 2)

GENERAL INSTRUCTIONS

This form is designed for submitting proposals to perform certain well operations and reports of such operations when completed as indicated on Federal and Indian lands pursuant to applicable Federal law and regulations. Any necessary special instructions concerning the use of this form and the number of copies to be submitted, particularly with regard to local area or regional procedures and practices, are either shown below, will be issued by or may be obtained from the local Federal office.

SPECIFIC INSTRUCTIONS

Item 4 - Locations on Federal or Indian land should be described in accordance with Federal requirements. Consult the local Federal office for specific instructions.

Item 13: Proposals to abandon a well and subsequent reports of abandonment should include such special information as is required by the local Federal office. In addition, such proposals and reports should include reasons for the abandonment; data on any former or present productive zones or other zones with present significant fluid contents not sealed off by cement or otherwise; depths (top and bottom) and method of placement of cement plugs; mud or other material placed below, between and above plugs; amount, size, method of parting of any casing, liner or tubing pulled and the depth to the top of any tubing left in the hole; method of closing top of well and date well site conditioned for final inspection looking for approval of the abandonment. If the proposal will involve **hydraulic fracturing operations**, you must comply with 43 CFR 3162.3-3, including providing information about the protection of usable water. Operators should provide the best available information about all formations containing water and their depths. This information could include data and interpretation of resistivity logs run on nearby wells. Information may also be obtained from state or tribal regulatory agencies and from local BLM offices.

NOTICES

The privacy Act of 1974 and the regulation in 43 CFR 2.48(d) provide that you be furnished the following information in connection with information required by this application.

AUTHORITY: 30 U.S.C. 181 et seq., 351 et seq., 25 U.S.C. 396; 43 CFR 3160.

PRINCIPAL PURPOSE: The information is used to: (1) Evaluate, when appropriate, approve applications, and report completion of subsequent well operations, on a Federal or Indian lease; and (2) document for administrative use, information for the management, disposal and use of National Resource lands and resources, such as: (a) evaluating the equipment and procedures to be used during a proposed subsequent well operation and reviewing the completed well operations for compliance with the approved plan; (b) requesting and granting approval to perform those actions covered by 43 CFR 3162.3-2, 3162.3-3, and 3162.3-4; (c) reporting the beginning or resumption of production, as required by 43 CFR 3162.4-1(c) and (d) analyzing future applications to drill or modify operations in light of data obtained and methods used.

ROUTINE USES: Information from the record and/or the record will be transferred to appropriate Federal, State, local or foreign agencies, when relevant to civil, criminal or regulatory investigations or prosecutions in connection with congressional inquiries or to consumer reporting agencies to facilitate collection of debts owed the Government.

EFFECT OF NOT PROVIDING THE INFORMATION: Filing of this notice and report and disclosure of the information is mandatory for those subsequent well operations specified in 43 CFR 3162.3-2, 3162.3-3, 3162.3-4.

The Paperwork Reduction Act of 1995 requires us to inform you that:

The BLM collects this information to evaluate proposed and/or completed subsequent well operations on Federal or Indian oil and gas leases.

Response to this request is mandatory.

The BLM would like you to know that you do not have to respond to this or any other Federal agency-sponsored information collection unless it displays a currently valid OMB control number.

BURDEN HOURS STATEMENT: Public reporting burden for this form is estimated to average 8 hours per response, including the time for reviewing instructions, gathering and maintaining data, and completing and reviewing the form. Direct comments regarding the burden estimate or any other aspect of this form to U.S. Department of the Interior, Bureau of Land Management (1004-0137), Bureau Information Collection Clearance Officer (WO-630), 1849 C St., N.W., Mail Stop 401 LS, Washington, D.C. 20240

Additional Information

Location of Well

0. SHL: NWNW / 558 FNL / 1252 FWL / TWSP: 20S / RANGE: 34E / SECTION: 31 / LAT: 32.5353279 / LONG: -103.6041182 (TVD: 0 feet, MD: 0 feet)
PPP: SESW / 100 FSL / 1980 FWL / TWSP: 20S / RANGE: 34E / SECTION: 30 / LAT: 32.5371418 / LONG: -103.6017578 (TVD: 9553 feet, MD: 9700 feet)
PPP: NWNE / 273 FNL / 2640 FEL / TWSP: 20S / RANGE: 34E / SECTION: 30 / LAT: 32.5506254 / LONG: -103.599603 (TVD: 9700 feet, MD: 14744 feet)
PPP: NENW / 1319 FNL / 1984 FWL / TWSP: 20S / RANGE: 34E / SECTION: 30 / LAT: 32.5477448 / LONG: -103.6017452 (TVD: 9700 feet, MD: 13455 feet)
BHL: SESE / 100 FSL / 660 FEL / TWSP: 20S / RANGE: 34E / SECTION: 30 / LAT: 32.5371625 / LONG: -103.5931612 (TVD: 9700 feet, MD: 21261 feet)

CONFIDENTIAL

TOPAZ 21602 30 FED COM

13 3/8		surface csg in a		17 1/2		inch hole.		Design Factors				Surface	
Segment	#/ft	Grade		Coupling	Joint	Collapse	Burst	Length	B@s	a-B	a-C	Weight	
"A"	54.50		j 55	stc	6.05	1.68	1.46	1,560	4	2.53	3.43	85,020	
"B"				stc				0				0	
w/8.4#/g mud, 30min Sfc Csg Test psig: 1,230								Totals:	1,560			85,020	
Comparison of Proposed to Minimum Required Cement Volumes Tail Cmt does not circ to sfc.													
Hole Size	Annular Volume	1 Stage Cmt Sx	1 Stage CuFt Cmt	Min Cu Ft	1 Stage % Excess	Drilling Mud Wt	Calc MASP	Req'd BOPE				Min Dist Hole-Cplg	
17 1/2	0.6946	960	1673	1084	54	8.30	1078	2M				1.56	

Site plot (pipe racks S or E) as per O.G. L100-A1 not found

10 3/4		casing inside the		13 3/8		Design Factors				Int 1		
Segment	#/ft	Grade		Coupling	Body	Collapse	Burst	Length	B@s	a-B	a-C	Weight
"A"	45.50		j 55	btc	4.37	1.12	1.38	3,600	2	2.72	1.94	163,800
"B"								0				0
w/8.4#/g mud, 30min Sfc Csg Test psig: 935								Totals:	3,600			163,800
The cement volume(s) are intended to achieve a top of 0 ft from surface or a 1560 overlap.												
Hole Size	Annular Volume	1 Stage Cmt Sx	1 Stage CuFt Cmt	Min Cu Ft	1 Stage % Excess	Drilling Mud Wt	Calc MASP	Req'd BOPE				Min Dist Hole-Cplg
12 1/4	0.1882	645	1154	755	53	10.00	1317	2M				0.25
D V Tool(s):								sum of sx	Σ CuFt			Σ%excess
t by stage % :									645 1154			53
Class 'H' tail cmt yld > 1.20												

Keep Casing full

8 5/8		casing inside the		10 3/4		Design Factors				Int 2		
Segment	#/ft	Grade		Coupling	Body	Collapse	Burst	Length	B@s	a-B	a-C	Weight
"A"	32.00		j 55	btc	2.71	0.97	0.76	5,810	2	1.38	1.92	185,920
"B"								0				0
w/8.4#/g mud, 30min Sfc Csg Test psig: 216								Totals:	5,810			185,920
The cement volume(s) are intended to achieve a top of 0 ft from surface or a 3600 overlap.												
Hole Size	Annular Volume	1 Stage Cmt Sx	1 Stage CuFt Cmt	Min Cu Ft	1 Stage % Excess	Drilling Mud Wt	Calc MASP	Req'd BOPE				Min Dist Hole-Cplg
9 7/8	0.1261	630	1151	762	51	8.60	2858	3M				0.13
Class 'C' tail cmt yld > 1.35												
Burst Frac Gradient(s) for Segment(s): A, B, C, D = 0.68, b, c, d <0.70 a Alt burst ok keep casing full												

5 1/2		casing inside the		8 5/8		Design Factors				Prod 1		
Segment	#/ft	Grade		Coupling	Body	Collapse	Burst	Length	B@s	a-B	a-C	Weight
"A"	20.00		p 110	btc	3.01	2.13	2.43	21,490	2	4.42	3.88	429,800
"B"								0				0
w/8.4#/g mud, 30min Sfc Csg Test psig: 2,343								Totals:	21,490			429,800
The cement volume(s) are intended to achieve a top of 5610 ft from surface or a 200 overlap.												
Hole Size	Annular Volume	1 Stage Cmt Sx	1 Stage CuFt Cmt	Min Cu Ft	1 Stage % Excess	Drilling Mud Wt	Calc MASP	Req'd BOPE				Min Dist Hole-Cplg
7 7/8	0.1733	1550	2651	2752	-4	9.40						0.91
Class 'H' tail cmt yld > 1.20												
Capitan Reef est top XXXX.												

Does not meet CFO 25% Excess on cement

PECOS DISTRICT DRILLING CONDITIONS OF APPROVAL

OPERATOR'S NAME: BTA OIL PRODUCERS LLC
WELL NAME & NO.: TOPAZ 21602 30 FED COM 3H
LOCATION: Section 31, T.20 S., R.34 E., NMP
COUNTY: Lea County, New Mexico

Create COAs

H₂S	Cave / Karst	Waste Prevention Rule
Present	Low	Waste Minimization Plan
Potash	R-111-Q Design	
R-111-Q	4-String: Open 2nd Int x Production (ICP 2 above Relief Zone)	
Wellhead	Casing	
Multibowl	4-String Well	
<input checked="" type="checkbox"/> Flex Hose	<input checked="" type="checkbox"/> Liner <input checked="" type="checkbox"/> Fluid Filled <input checked="" type="checkbox"/> Casing Clearance	
<input checked="" type="checkbox"/> Break Testing	Cementing	
	<input type="checkbox"/> DV Tool <input checked="" type="checkbox"/> Bradenhead <input checked="" type="checkbox"/> Echometer	
	<input type="checkbox"/> Offline Cement <input type="checkbox"/> Open Annulus <input type="checkbox"/> Pilot Hole	
Special Requirements		
<input checked="" type="checkbox"/> Capitan Reef	<input type="checkbox"/> Water Disposal	<input checked="" type="checkbox"/> COM <input type="checkbox"/> Unit

A. HYDROGEN SULFIDE

A Hydrogen Sulfide (H₂S) Drilling Plan shall be activated AT SPUD. As a result, the Hydrogen Sulfide area must meet 43 CFR part 3170 requirements, which includes equipment and personnel/public protection items. If Hydrogen Sulfide is encountered, please provide measured values and formations to the BLM.

APD is within the R-111-Q defined boundary. Operator must follow all procedures and requirements listed within the updated order.

B. CASING

1. The 13-3/8 inch surface casing shall be set at approximately 1560 feet (a minimum of 70' into the Rustler Anhydrite, above the salt, and below usable fresh water) and cemented to the surface.
 - a. If cement does not circulate to the surface, the appropriate BLM office shall be notified

- and a temperature survey utilizing an electronic-type temperature survey with surface log readout will be used or a cement bond log shall be run to verify the top of the cement. Temperature survey will be run a minimum of six hours after pumping cement and ideally between 8-10 hours after completing the cement job.
- b. Wait on cement (WOC) time for a primary cement job will be a minimum of **8 hours** or **500 pounds compressive strength**, whichever is greater (including lead cement.)
 - c. Wait on cement (WOC) time for a remedial job will be a minimum of 4 hours after bringing cement to surface or 500 pounds compressive strength, whichever is greater.
 - d. If cement falls back, remedial cementing will be done prior to drilling out that string.

1st Intermediate casing must be kept fluid filled to meet BLM minimum collapse requirement.

2. The minimum required fill of cement behind the **10-3/4** inch 1st intermediate casing is **cement to surface**. If cement does not circulate, see B.1.a, c-d above.
 - **Wait on cement (WOC) time for a primary cement job is to include the lead cement slurry** due to the presence of cave/karst, Capitan Reef, or potash features.

2nd Intermediate casing must be kept fluid filled to meet BLM minimum collapse requirement.

3. The minimum required fill of cement behind the **8-5/8** inch 2nd intermediate casing is **cement to surface**. If cement does not circulate, see B.1.a, c-d above.
 - **Special Capitan Reef Requirement:** Ensure freshwater based mud is used across the Capitan interval.
 - **Wait on cement (WOC) time for a primary cement job is to include the lead cement slurry** due to the presence of cave/karst, Capitan Reef, or potash features.
4. The minimum required fill of cement behind the **5-1/2** inch production casing is **500 feet** into the previous casing but not higher than the engineered weak point and USGS Marker Bed No. 126 (base of the McNutt Potash ore zone.)
 - Operator must verify top of cement per R-111-Q requirements. Submit results to the BLM. Operator shall use one of the approved methods for cement verification located in the **General Requirements, Section A.1.**
 - **Wait on cement (WOC) time for a primary cement job is to include the lead cement slurry** due to the presence of cave/karst, Capitan Reef, or potash features.

Bradenhead Squeeze: Operator has proposed to cement in two stages by conventionally cementing the first stage and performing a bradenhead squeeze on the second stage, contingent upon no returns to surface.

- a. **First stage:** Operator will cement with intent to reach the top of the **Brushy Canyon**.
- b. **Second stage:** Operator to squeeze and top-out. Cement to meet requirements listed for this casing string. If cement does not circulate see B.1.a, c-d above.

Operator has proposed to pump down **Intermediate 2 X Production** annulus. Submit results to the BLM. If cement does not tie back into the previous casing shoe, a third stage remediation BH may be performed. The appropriate BLM office shall be notified.

- Operator shall run a CBL from TD of the **Intermediate 2** casing to tieback requirements after the second stage BH to verify TOC.
- **Operator shall run Echo-meter to verify Cement Slurry/Fluid top in the annulus.** Submit results to the BLM. No displacement fluid/wash out shall be utilized at the top of the cement slurry between second stage BH and top out.
 - Operator must use a limited flush fluid volume of 1 bbl following backside cementing procedures.
 - No displacement fluid/wash out shall be utilized at the top of the cement slurry during second stage bradenhead when running Echo-meter if cement is required to surface.
 - Adjust cement volume and excess based on a fluid caliper or similar method that reflects the as-drilled size of the wellbore.
- **A monitored open annulus will be incorporated during completion by leaving the above annulus un-cemented and monitored.** Operator must follow all monitoring requirements listed within R-111-Q. Tieback shall be met within **180 days**.
- Operator has proposed an open annulus completion in R-111-Q. Operator shall provide a method of verification pre-completion top of cement. **Submit results to the BLM.**
- A pressure monitoring device must be installed at surface on both the intermediate annulus and the production annulus for the life of the well.
- During hydraulic fracturing operations, a pressure relief valve or appropriate venting system shall be installed **in all designed open annuli** in the event of a production casing failure.
- **In the event of a casing failure during completion**, the operator **must** contact the BLM engineer (575-706-2779) and inspection staff listed in the **General Requirements**.

C. PRESSURE CONTROL

1. Operator has proposed a multi-bowl wellhead assembly. Minimum working pressure of the blowout preventer (BOP) and related equipment (BOPE) required for drilling below the surface casing shoe shall be **10,000 (10M) psi**. **Variance is approved to use a 5000 (5M) annular which shall be tested to 5000 (5M) psi.**
 - a. Wellhead shall be installed by manufacturer's representatives, submit documentation with subsequent sundry.

- b. If the welding is performed by a third party, the manufacturer's representative shall monitor the temperature to verify that it does not exceed the maximum temperature of the seal.
 - c. Manufacturer representative shall install the test plug for the initial BOP test.
 - d. If the cement does not circulate and one-inch operations would have been possible with a standard wellhead, the well head shall be cut off, cementing operations performed and another wellhead installed.
 - e. Whenever any seal subject to test pressure is broken, all the tests in 43 CFR 3172 must be followed.
2. Variance approved to use flex line from BOP to choke manifold. Manufacturer's specification to be readily available. No external damage to flex line. Flex line to be installed as straight as possible (no hard bends).
 3. Break testing has been approved for this well ONLY on those intervals utilizing a 5M BOPE or less. **(Annular preventer must be tested to a minimum of 70% of BOPE working pressure and shall be higher than the MASP.)** If in the event break testing is not utilized, then a full BOPE test would be conducted.
 - a. Variance only pertains to the intermediate hole-sections and no deeper than the Bone Springs formation. **BOPE Break Testing is NOT permitted to drill the production hole section.**
 - b. While in transfer between wells, BOPE shall be secured by the hydraulic carrier or cradle.
 - c. A full BOPE test is required prior to drilling the first deep intermediate hole section. If any subsequent hole interval is deeper than the first, a full BOPE test will be required. (200' TVD tolerance between intermediate shoes is allowable).
 - d. As a minimum, a full BOPE test shall be performed at 21-day intervals.
 - e. In the event any repairs or replacement of the BOPE is required, the BOPE shall test as per **43 CFR 3172**. Any well control event while drilling require notification to the BLM Petroleum Engineer (**575-706-2779**) prior to the commencement of any BOPE Break Testing operations.

D. SPECIAL REQUIREMENT(S)

Communitization Agreement:

- The operator will submit a Communitization Agreement to the Santa Fe Office, 301 Dinosaur Trail Santa Fe, New Mexico 87508, at least 90 days before the anticipated date of first production from a well subject to a spacing order issued by the New Mexico Oil Conservation Division. The Communitization Agreement will include the signatures of all working interest owners in all Federal and Indian leases subject to the Communitization Agreement (i.e., operating rights owners and lessees of record), or certification that the operator has obtained the written signatures of all such owners and will make those signatures available to the BLM immediately upon request.

- The operator will submit an as-drilled survey well plat of the well completion, but are not limited to, those specified in 43 CFR 3171 and 3172.
- If the operator does not comply with this condition of approval, the BLM may take enforcement actions that include, but are not limited to, those specified in 43 CFR 3163.1.
- In addition, the well sign shall include the surface and bottom hole lease numbers. When the Communitization Agreement number is known, it shall also be on the sign.

Casing Clearance

String does not meet 0.422" clearance requirement per 43 CFR 3172. Cement tieback requirement increased 100' for 1st Intermediate and 2nd Intermediate casing tieback. Operator may contact approving engineer to discuss changing casing set depth or grade to meet clearance requirement.

GENERAL REQUIREMENTS

The BLM is to be notified in advance for a representative to witness:

- a. Spudding well (minimum of 24 hours)
- b. Setting and/or Cementing of all casing strings (minimum of 4 hours)
- c. BOPE tests (minimum of 4 hours)

For multi-well pads, notifications for the following operations may be made together going from one well to the next. This does **NOT** apply to notifications for wells in the R111Q potash area:

- Casing run
- Offline cementing
- Break testing

Contact Lea County Petroleum Engineering Inspection Staff:

Call the Hobbs Field Station, 414 West Taylor, Hobbs NM 88240, (575) 689-5981

1. Unless the production casing has been run and cemented or the well has been properly plugged, the drilling rig shall not be removed from over the hole without prior approval.
 - a. In the event the operator proposed to drill multiple wells utilizing a skid / walking rig. Operator shall secure the wellbore on the current well, after installing and testing the wellhead, by installing a blind flange of like pressure rating to the wellhead and a pressure gauge that can be monitored while drilling is performed on the other well(s).
 - b. When the operator proposes to set surface casing with Spudder Rig
 - i. Notify the BLM when moving in and removing the Spudder Rig.
 - ii. Notify the BLM when moving in the 2nd Rig. Rig to be moved in within 90 days of notification that Spudder Rig has left the location.

- iii. BOP/BOPE test to be conducted per **43 CFR 3172** as soon as 2nd Rig is rigged up on swell.
 2. Floor controls are required for 3M or Greater systems. These controls will be on the rig floor, unobstructed, readily accessible to the driller and will always be operational during drilling and/or completion activities. Rig floor is defined as the area immediately around the rotary table; the area immediately above the substructure on which the draw works are located, this does not include the doghouse or stairway area.
 3. For intervals in which cement to surface is required, cement to surface should be verified with a visual check and density or pH check to differentiate cement from spacer and drilling mud. The results should be documented in the driller's log and daily reports.

A. CASING & CEMENT

1. The current acceptable methods of cement verification are as follows:
 - i. Observing cement circulated to surface,
 - ii. Cement Bond Log (CBL),
 - iii. Temperature log within 8-10 hours after completing the cement job,
 - iv. Echometer (if a second-stage bradenhead is being utilized and operator was granted approval prior to operations.)
2. Changes to the approved APD casing program need prior approval if the items substituted are of lesser grade or different casing size or are non-API. The Operator can exchange the components of the proposal with that of superior strength (i.e. changing from J-55 to N-80, or from 36# to 40#). Changes to the approved cement program need prior approval if the altered cement plan has less volume or strength or if the changes are substantial (i.e. Multistage tool, ECP, etc.). The initial wellhead installed on the well will remain on the well with spools used as needed.
3. Wait on cement (WOC) for Potash Areas: After cementing but before commencing any tests, the casing string shall stand cemented under pressure until both of the following conditions have been met: 1) cement reaches a minimum compressive strength of 500 psi for all cement blends of both lead and tail cement, 2) until cement has been in place at least 8 hours. WOC time will be recorded in the driller's log. The casing integrity test can be done (prior to the cement setting up) immediately after bumping the plug.
4. Wait on cement (WOC) for Water Basin: After cementing but before commencing any tests, the casing string shall stand cemented under pressure until both of the following conditions have been met: 1) cement reaches a minimum compressive strength of 500 psi at the shoe, 2) until cement has been in place at least 8 hours. WOC time will be recorded in the driller's log. See individual casing strings for details regarding lead cement slurry requirements. The casing integrity test can be done (prior to the cement setting up) immediately after bumping the plug.

5. Provide compressive strengths including hours to reach required 500 pounds compressive strength prior to cementing each casing string. Well specific cement details must be onsite prior to pumping the cement for each casing string.
6. No pea gravel permitted for remedial or fall back remedial without prior authorization from the BLM engineer.
7. On that portion of any well approved for a 5M BOPE system or greater, a pressure integrity test of each casing shoe shall be performed. Formation at the shoe shall be tested to a minimum of the mud weight equivalent anticipated to control the formation pressure to the next casing depth or at total depth of the well. This test shall be performed before drilling more than 20 feet of new hole.
8. If hard band drill pipe is rotated inside casing, returns will be monitored for metal. If metal is found in samples, drill pipe will be pulled and rubber protectors which have a larger diameter than the tool joints of the drill pipe will be installed prior to continuing drilling operations.
9. Whenever a casing string is cemented in the R-111-Q potash area, the NMOCD requirements shall be followed.

B. PRESSURE CONTROL

1. All blowout preventer (BOP) and related equipment (BOPE) shall comply with well control requirements as described in **43 CFR 3172**.
2. If a variance is approved for a flexible hose to be installed from the BOP to the choke manifold, the following requirements apply: The flex line must meet the requirements of API 16C. Check condition of flexible line from BOP to choke manifold, replace if exterior is damaged or if line fails test. Line to be as straight as possible with no hard bends and is to be anchored according to Manufacturer's requirements. The flexible hose can be exchanged with a hose of equal size and equal or greater pressure rating. Anchor requirements, specification sheet and hydrostatic pressure test certification matching the hose in service, to be onsite for review. These documents shall be posted in the company man's trailer and on the rig floor.
3. 5M or higher system requires an HCR valve, remote kill line and annular to match. The remote kill line is to be installed prior to testing the system and tested to stack pressure.
4. If the operator has proposed a multi-bowl wellhead assembly in the APD. The following requirements must be met:
 - i. Wellhead shall be installed by manufacturer's representatives, submit documentation with subsequent sundry.
 - ii. If the welding is performed by a third party, the manufacturer's representative shall monitor the temperature to verify that it does not exceed the maximum temperature of the seal.
 - iii. Manufacturer representative shall install the test plug for the initial BOP test.

- iv. Whenever any seal subject to test pressure is broken, all the tests in 43 CFR 3172.6(b)(9) must be followed.
 - v. If the cement does not circulate and one-inch operations would have been possible with a standard wellhead, the well head shall be cut off, cementing operations performed and another wellhead installed.
5. The appropriate BLM office shall be notified a minimum of 4 hours in advance for a representative to witness the tests.
- i. In a water basin, for all casing strings utilizing slips, these are to be set as soon as the crew and rig are ready and any fallback cement remediation has been done. The casing cut-off and BOP installation can be initiated four hours after installing the slips, which will be approximately six hours after bumping the plug. For those casing strings not using slips, the minimum wait time before cut-off is eight hours after bumping the plug. BOP/BOPE testing can begin after cut-off or once cement reaches 500 psi compressive strength (including lead cement), whichever is greater. However, if the float does not hold, cut-off cannot be initiated until cement reaches 500 psi compressive strength (including lead when specified).
 - ii. In potash areas, for all casing strings utilizing slips, these are to be set as soon as the crew and rig are ready and any fallback cement remediation has been done. For all casing strings, casing cut-off and BOP installation can be initiated at twelve hours after bumping the cement plug. The BOPE test can be initiated after bumping the cement plug with the casing valve open. (This only applies to single stage cement jobs, prior to the cement setting up.)
 - iii. The tests shall be done by an independent service company utilizing a test plug not a cup or J-packer and can be initiated immediately with the casing valve open. The operator also has the option of utilizing an independent tester to test without a plug (i.e. against the casing) pursuant to **43 CFR 3172** with the pressure not to exceed 70% of the burst rating for the casing. Any test against the casing must meet the WOC time for 8 hours or 500 pounds compressive strength, whichever is greater, prior to initiating the test (see casing segment as lead cement may be critical item).
 - iv. The test shall be run on a 5000-psi chart for a 2-3M BOP/BOP, on a 10000-psi chart for a 5M BOP/BOPE and on a 15000-psi chart for a 10M BOP/BOPE. If a linear chart is used, it shall be a one-hour chart. A circular chart shall have a maximum 2-hour clock. If a twelve hour or twenty-four-hour chart is used, tester shall make a notation that it is run with a two -our clock.
 - v. The results of the test shall be reported to the appropriate BLM office.
 - vi. All tests are required to be recorded on a calibrated test chart. A copy of the BOP/BOPE test chart and a copy of independent service company test will be submitted to the appropriate BLM office.

- vii. The BOP/BOPE test shall include a low-pressure test from 250 to 300 psi. The test will be held for a minimum of 10 minutes if test is done with a test plug and 30 minutes without a test plug. This test shall be performed prior to the test at full stack pressure.
- viii. BOP/BOPE must be tested by an independent service company within 500 feet of the top of the Wolfcamp formation if the time between the setting of the intermediate casing and reaching this depth exceeds 20 days. This test does not exclude the test prior to drilling out the casing shoe as per **43 CFR 3172**.

C. DRILLING MUD

Mud system monitoring equipment, with derrick floor indicators and visual and audio alarms, shall be operating before drilling into the Wolfcamp formation, and shall be used until production casing is run and cemented.

D. WASTE MATERIAL AND FLUIDS

All waste (i.e. drilling fluids, trash, salts, chemicals, sewage, gray water, etc.) created because of drilling operations and completion operations shall be safely contained and disposed of properly at a waste disposal facility. No waste material or fluid shall be disposed of on the well location or surrounding area. Porto-johns and trash containers will be on-location during fracturing operations or any other crew-intensive operations.

JS 3/17/2026

TOPAZ 21602 30 FED COM 3H

Old Name	Old Footages	SHL		KOP		FTP		DP1 -TURN POINT 1		NPZ1-OFFSET 1		Apex-MTP		NPZ2-OFFSET 2		DP2-TURN POINT 2		LTP		BHL	
TOPAZ FED COM 301H		Sec 31 20S 34E		Sec 30 20S 34E		Sec 30 20S 34E		Sec 30 20S 34E		Sec 30 20S 34E		Sec 30 20S 34E		Sec 30 20S 34E		Sec 30 20S 34E		Sec 30 20S 34E		Sec 30 20S 34E	
		558 FNL	1252 FWL	100 FSL	1980 FWL	100 FSL	1980 FWL	1418 FNL	1980 FWL	330 FNL	2553 FWL	99 FNL	1982 FEL	330 FNL	1238 FEL	1424 FNL	660 FEL	100 FSL	660 FEL	100 FSL	660 FEL
New Name	New Footages	SHL		KOP		FTP		DP1 -TURN POINT 1		NPZ1		Apex- MID TURN		NPZ2		DP2- TURN POINT 2		LTP		BHL	
TOPAZ 21602 30 FED COM 3H		Sec 31 20S 34E		Sec 30 20S 34E		Sec 30 20S 34E		Sec 30 20S 34E		Sec 30 20S 34E		Sec 30 20S 34E		Sec 30 20S 34E		Sec 30 20S 34E		Sec 30 20S 34E		Sec 30 20S 34E	
		551 FNL	1223 FWL	50 FSL	350 FWL	100 FSL	350 FWL	750 FNL	350 FWL	330 FNL	503 FWL	100 FNL	1000 FWL	330 FNL	1495 FWL	750 FNL	1650 FWL	100 FSL	1650 FWL	50 FSL	1650 FWL



BTA Oil Producers, LLC
 104 S Pecos
 Midland, TX 79701

WELL: Topaz 21602 30 Fed Com #03H
TVD: 11,275
MD: 22,120

DRILLING PLAN

Casing Program

Hole Size	Csg. Size	From (MD)	To (MD)	From (TVD)	To (TVD)	Tapered String	Weight (lbs)	Grade	Conn.	Collapse	Burst	Body Tension	Joint Tension	Dry/Buoyant	Mud Weight (ppg)
17 1/2	13 3/8	0	1560	0	1560	No	54.5	J-55	STC	1.7	4.1	10.0	6.0	Dry	8.3
12 1/4	10 3/4	0	3600	0	3560	No	45.5	J-55	LTC	2.0	1.9	4.4	4.9	Dry	10
Liner 9 7/8	8 5/8	0	5810	0	5756	No	32	J-55	BTC	1.9	1.5	2.7	2.2	Dry	8.6
7 7/8	5 1/2	0	22120	0	11275	No	20	P110	BTC	2.0	2.2	1.9	2.0	Dry	9.4

Cementing Program

Csg. Size	Stage Tool Depth	Top MD of Segment	Bottom MD of Segment	Cement Type	Quantity (sk)	Yield (cu. Ft./sk)	Density (lbs. gal)	Volume (cu.ft.)	% Excess	Additives
13 3/8	Lead	0	1260	Class C	695	1.9	12.8	1321	50%	2% CaCl2
	Tail	1260	1560	Class C	265	1.33	14.8	352	50%	2% CaCl2
10 3/4	Lead	0	3100	Class C	520	1.9	12.8	988	50%	0.5% CaCl2
	Tail	3100	3600	Class C	125	1.33	14.8	166	50%	1% CaCl2
8 5/8	Lead	0	5310	Class C	550	1.9	12.8	1045	50%	0.5% CaCl2
	Tail	5310	5810	Class C	80	1.33	14.8	106	25%	1% CaCl2
5 1/2	Lead	6310	10788	Class C			11		0%	
	Tail	10788	22120	Class C	1610	1.71	13	2753	0%	4% Gel

* Production cement TOC is planned for 500' below 8-5/8" shoe with 0% excess

* BTA will perform a Braden head job within 180 days of completion to tie back 500' into the 8-5/8" intermediate.

4-String Design – Open 1st Int x Production Casing (ICP 2 above relief zone)

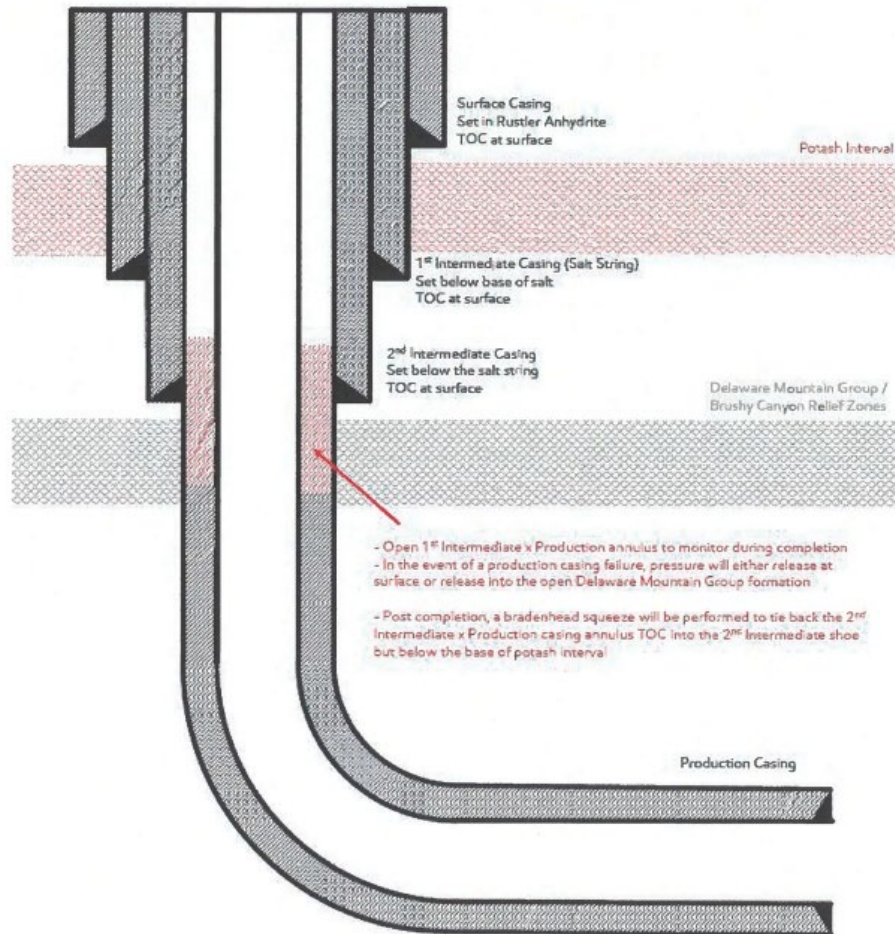

[Figure E] 4 String – Uncemented Annulus between 2nd Intermediate and Production Casing Strings

Sante Fe Main Office
Phone: (505) 476-3441

General Information
Phone: (505) 629-6116

Online Phone Directory
<https://www.emnrd.nm.gov/ocd/contact-us>

State of New Mexico
Energy, Minerals and Natural Resources
Oil Conservation Division
1220 S. St Francis Dr.
Santa Fe, NM 87505

CONDITIONS

Action 565415

CONDITIONS

Operator: BTA OIL PRODUCERS, LLC 104 S Pecos Midland, TX 79701	OGRID: 260297
	Action Number: 565415
	Action Type: [C-103A] NOI Change of Plans (C-103A)

CONDITIONS

Created By	Condition	Condition Date
jeffrey.harrison	Prior to production of this well a change to the well name/number is required to comply with the OCD well naming convention.	4/29/2026
jeffrey.harrison	NSL required before production if any of the lateral is completed within 330' (perpendicular to the trajectory) of the defined spacing unit.	4/29/2026
jeffrey.harrison	Property code is now 339126.	4/29/2026
jeffrey.harrison	All previous COA's not addressed within the updated COA's still apply.	4/29/2026