

marbob
energy corporation

OIL CONSERVATION DIVISION
RECEIVED

'92 MAR 23 AM 9 00

March 20, 1992

Oil Conservation Division
P. O. Box 2088
Santa Fe, New Mexico 87501

Attn: Michael Stogner, Director

104/65
RE: Produced Water
Injection Application
Cedar Lake Abo Pool
Sinclair Turner B 65
Sinclair Turner B 69
Eddy County, New Mexico

Dear Mr. Stogner:

Enclosed herewith in duplicate is an Application of Marbob Energy Corporation for the authority to inject produced water in the Sinclair Turner B 65 located 330' FSL and 1980' FWL Section 20 and the Sinclair B 69 located 330' FNL and 2310' FEL Section 29; Township ~~29~~ South, Range 31 East, Eddy County, New Mexico. This application is made pursuant to Rule 701A of the Division in Rules and Regulations for Notice and Hearing for disposal into the Abo formation, which is the same formation that the wells were originally producing from prior to being placed in a T/A'd status. The Turner B No. 65 and No. 69 are located on offset 40-acre proration units to Marbob Energy's Turner B No. 73 which is currently disposing of produced water into the Abo formation. The Turner B No. 73 was authorized by the O.C.D. as a Salt Water Disposal well under order number R-3378. Copies of this application will be furnished to each offset leasehold operator within 1/2 mile of the wells. Also, the Bureau of Land Management, as the owner of the surface of the land, will be notified of this application.

Mr. Stogner, Marbob Energy Corporation respectfully requests that a hearing be granted and scheduled on April 16th for the consideration of this application. Exhibits are included with this application, however complete documentation supporting this request will be provided at the formal hearing. Thank you for your consideration of this application.

Sincerely,

A handwritten signature in cursive script that reads "David Martin".

David Martin
Land Department

DM/mm
Enclosures

Case 10465

APPLICATION FOR AUTHORIZATION TO INJECT DIVISION

I. Purpose: Secondary Recovery Pressure Maintenance Disposal Storage
Application qualifies for administrative approval? yes no

II. Operator: Marbob Energy Corporation

Address: P. O. Drawer 217, Artesia, NM 88210

Contact party: Raye Miller Phone: (505) 748-3303

III. Well data: Complete the data required on the reverse side of this form for each well proposed for injection. Additional sheets may be attached if necessary.

IV. Is this an expansion of an existing project? yes no
If yes, give the Division order number authorizing the project _____

V. Attach a map that identifies all wells and leases within two miles of any proposed injection well with a one-half mile radius circle drawn around each proposed injection well. This circle identifies the well's area of review.

VI. Attach a tabulation of data on all wells of public record within the area of review which penetrate the proposed injection zone. Such data shall include a description of each well's type, construction, date drilled, location, depth, record of completion, and a schematic of any plugged well illustrating all plugging detail.

VII. Attach data on the proposed operation, including:
1. Proposed average and maximum daily rate and volume of fluids to be injected;
2. Whether the system is open or closed;
3. Proposed average and maximum injection pressure;
4. Sources and an appropriate analysis of injection fluid and compatibility with the receiving formation if other than reinjected produced water; and
5. If injection is for disposal purposes into a zone not productive of oil or gas at or within one mile of the proposed well, attach a chemical analysis of the disposal zone formation water (may be measured or inferred from existing literature, studies, nearby wells, etc.).

VIII. Attach appropriate geological data on the injection zone including appropriate lithologic detail, geological name, thickness, and depth. Give the geologic name, and depth to bottom of all underground sources of drinking water (aquifers containing waters with total dissolved solids concentrations of 10,000 mg/l or less) overlying the proposed injection zone as well as any such source known to be immediately underlying the injection interval.

IX. Describe the proposed stimulation program, if any.

X. Attach appropriate logging and test data on the well. (If well logs have been filed with the Division they need not be resubmitted.)

XI. Attach a chemical analysis of fresh water from two or more fresh water wells (if available and producing) within one mile of any injection or disposal well showing location of wells and dates samples were taken.

XII. Applicants for disposal wells must make an affirmative statement that they have examined available geologic and engineering data and find no evidence of open faults or any other hydrologic connection between the disposal zone and any underground source of drinking water.

XIII. Applicants must complete the "Proof of Notice" section on the reverse side of this form.

XIV. Certification

I hereby certify that the information submitted with this application is true and correct to the best of my knowledge and belief.

Name: John R. Gray Title President

Signature: _____ Date: _____

If the information required under Sections VI, VIII, X, and XI above has been previously submitted, it need not be duplicated and resubmitted. Please show the date and circumstance of the earlier submittal.

III. WELL DATA

A. The following well data must be submitted for each injection well covered by this application. The data must be both in tabular and schematic form and shall include:

- (1) Lease name; Well No.; location by Section, Township, and Range; and footage location within the section.
- (2) Each casing string used with its size, setting depth, sacks of cement used, hole size, top of cement, and how such top was determined.
- (3) A description of the tubing to be used including its size, lining material, and setting depth.
- (4) The name, model, and setting depth of the packer used or a description of any other seal system or assembly used.

Division District offices have supplies of Well Data Sheets which may be used or which may be used as models for this purpose. Applicants for several identical wells may submit a "typical data sheet" rather than submitting the data for each well.

B. The following must be submitted for each injection well covered by this application. All items must be addressed for the initial well. Responses for additional wells need be shown only when different. Information shown on schematics need not be repeated.

- (1) The name of the injection formation and, if applicable, the field or pool name.
- (2) The injection interval and whether it is perforated or open-hole.
- (3) State if the well was drilled for injection or, if not, the original purpose of the well.
- (4) Give the depths of any other perforated intervals and detail on the sacks of cement or bridge plugs used to seal off such perforations.
- (5) Give the depth to and name of the next higher and next lower oil or gas zone in the area of the well, if any.

XIV. PROOF OF NOTICE

All applicants must furnish proof that a copy of the application has been furnished, by certified or registered mail, to the owner of the surface of the land on which the well is to be located and to each leasehold operator within one-half mile of the well location.

Where an application is subject to administrative approval, a proof of publication must be submitted. Such proof shall consist of a copy of the legal advertisement which was published in the county in which the well is located. The contents of such advertisement must include:

- (1) The name, address, phone number, and contact party for the applicant;
- (2) the intended purpose of the injection well; with the exact location of single wells or the section, township, and range location of multiple wells;
- (3) the formation name and depth with expected maximum injection rates and pressures; and
- (4) a notation that interested parties must file objections or requests for hearing with the Oil Conservation Division, P. O. Box 2088, Santa Fe, New Mexico 87501 within 15 days.

NO ACTION WILL BE TAKEN ON THE APPLICATION UNTIL PROPER PROOF OF NOTICE HAS BEEN SUBMITTED.

NOTICE: Surface owners or offset operators must file any objections or requests for hearing of administrative applications within 15 days from the date this application was mailed to them.

INJECTION WELL DATA SHEET

Marbob Energy Corporation Sinclair Turner B
OPERATOR LEASE
65 330' FSL 1980 FWL 20 17S 31E
WELL NO. FOOTAGE LOCATION SECTION TOWNSHIP RANGE

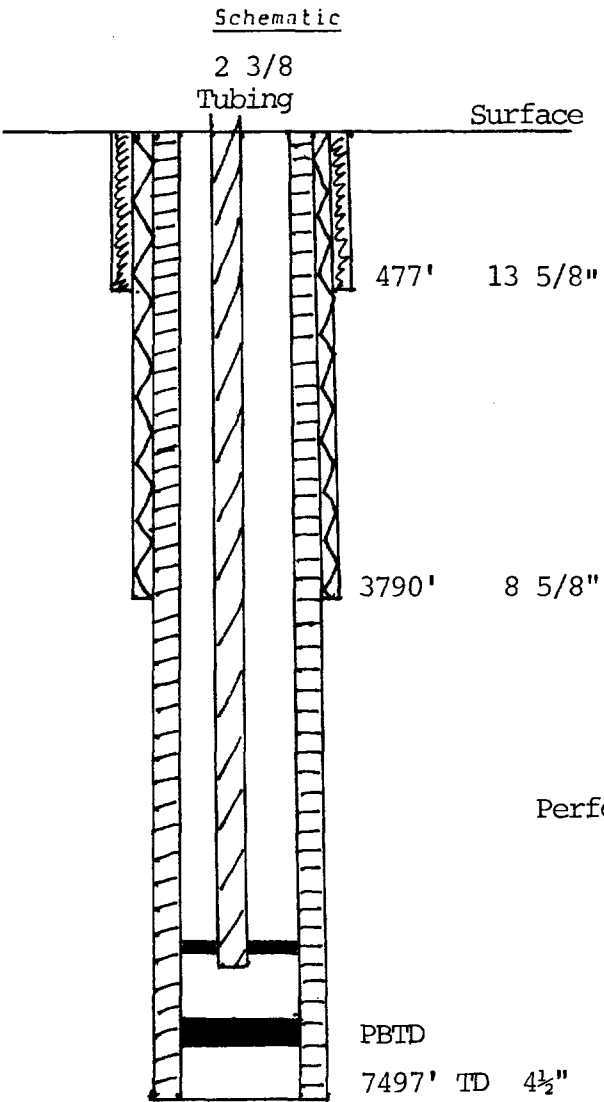

Tabular Data

Surface Casing
 Size 13 5/8 O.D. " Cemented with 525 sx.
 TOC Surface feet determined by Cement Circulated
 Hole size 17 1/2"

Intermediate Casing
 Size 8 5/8 O.D. " Cemented with 2100 sx.
 TOC Surface feet determined by Cement Circulated
 Hole size 11"

Long string
 Size 4 1/2 O.D. " Cemented with 500 + 450 sx.
 TOC 1184' feet determined by Temperature Survey
 Hole size 7 7/8"
 Total depth 7497'

Injection interval
Perforated 6890 feet to 7480 feet
 (perforated or open-hole, indicate which)

Tubing size 2 3/8" lined with Plastic Coating set in a
(material)
Halliburton Trump Pkr. packer at 6800' feet
(brand and model)

(or describe any other casing-tubing seal).

Other Data

- Name of the injection formation Abo
- Name of field or Pool (if applicable) Cedar Lake Abo
- Is this a new well drilled for injection? Yes No
 If no, for what purpose was the well originally drilled? Oil Well Producing from the Abo Formation.
- Has the well ever been perforated in any other zone(s)? List all such perforated intervals and give plugging detail (sacks of cement or bridge plug(s) used) No
- Give the depth to and name of any overlying and/or underlying oil or gas zones (pools) in this area. Grayburg Jackson Queen, Seven Rivers, Grayburg, San Andres, 1901-4880

INJECTION WELL DATA SHEET

<u>Marbob Energy Corporation</u>		<u>Sinclair Turner B</u>		
OPERATOR		LEASE		
<u>69</u>	<u>330' FNL, 2310' FEL</u>	<u>29</u>	<u>17S</u>	<u>31E</u>
WELL NO.	FOOTAGE LOCATION	SECTION	TOWNSHIP	RANGE

Schematic

Tabular Data

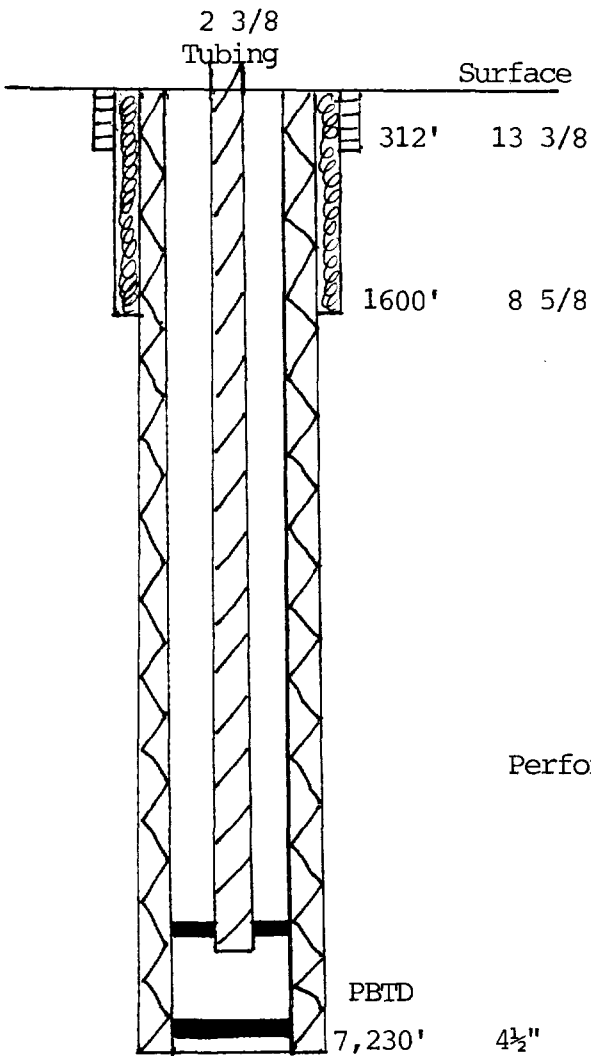

Surface Casing
 Size 13 3/8 O.D. " Cemented with 100 sx.
 TOC 143' feet determined by Calc.
 Hole size 17 1/2"

Intermediate Casing
 Size 8 5/8 O.D. " Cemented with 1100 sx.
 TOC Surface feet determined by Cement, Circulated
 Hole size 11"

Long string
 Size 4 1/2 O.D. " Cemented with 1100 sx.
 TOC 1400' feet determined by Temperature Survey
 Hole size 7 7/8"
 Total depth 7230'

Injection interval
 Perforated 6890 feet to 7230 feet
 (perforated or open-hole, indicate which)

Tubing size 2 3/8" lined with Plastic Coating set in a
(material)
Halliburton Trump Pkr. packer at 6800 feet
(brand and model)

(or describe any other casing-tubing seal).

Other Data

- Name of the injection formation Abo
- Name of Field or Pool (if applicable) Cedar Lake Abo
- Is this a new well drilled for injection? Yes No
 If no, for what purpose was the well originally drilled? Oil Well Producing
from the Abo Formation.
- Has the well ever been perforated in any other zone(s)? List all such perforated intervals and give plugging detail (sacks of cement or bridge plug(s) used) No
- Give the depth to and name of any overlying and/or underlying oil or gas zones (pools) in this area. Grayburg Jackson Queen, Seven Rivers, Grayburg, San Andres