

H.L. BROWN
FEDERAL 27 #2
ROOSEVELT COUNTY, N.M.

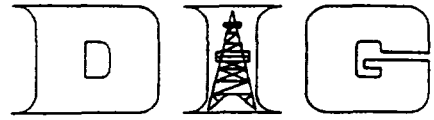

HORIZONTAL PLAN
SCALE: 20 FEET/DIVISION

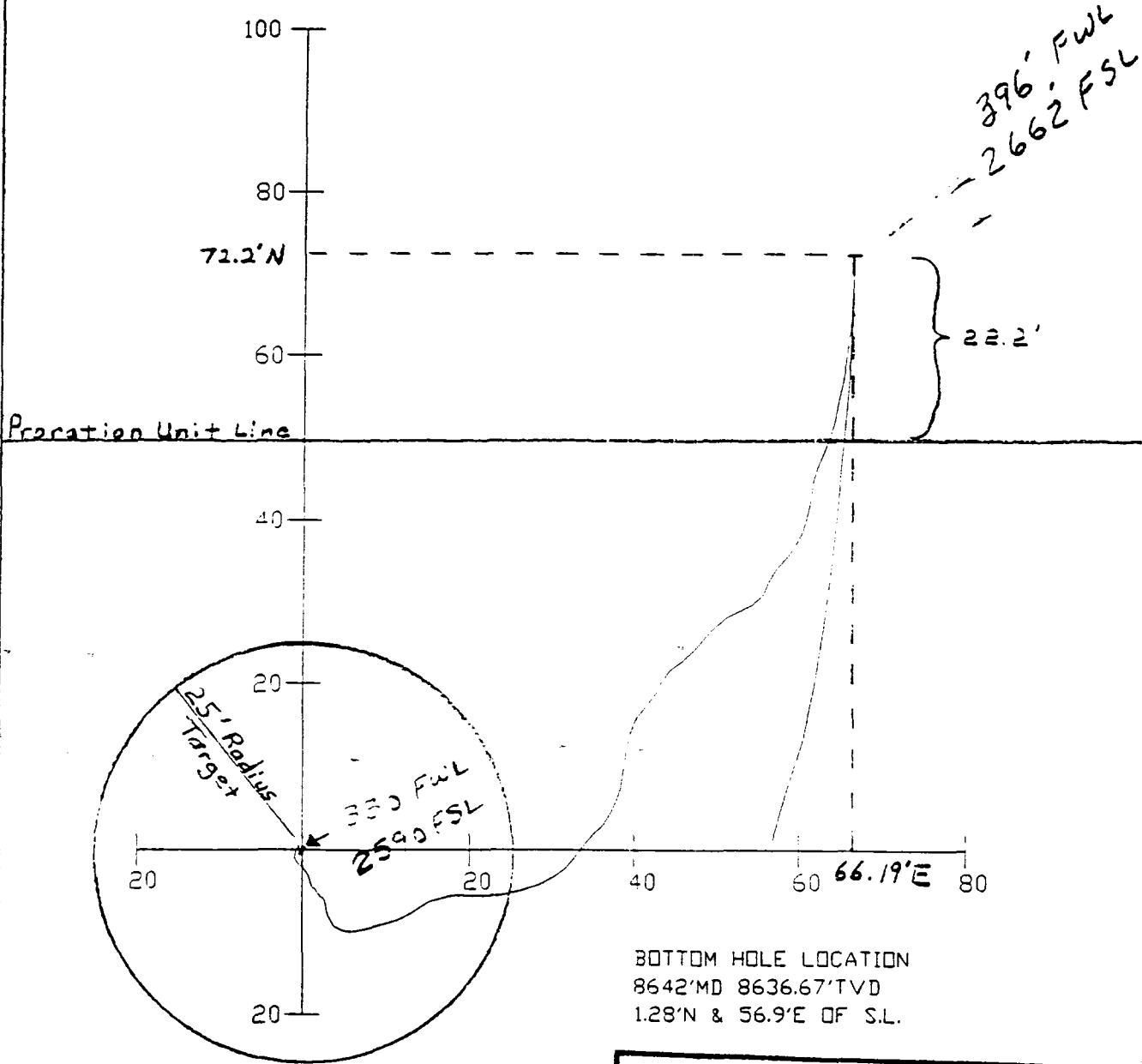

BOTTOM HOLE LOCATION
8642' MD 8636.67' TVD
1.28' N & 56.9' E OF S.L.

BEFORE EXAMINER
Oil Conservation Division
BROWN Exhibit No. 3
Case No. 10900

STATE OF NEW MEXICO
ENERGY, MINERALS AND NATURAL RESOURCES DEPARTMENT
OIL CONSERVATION DIVISION

IN THE MATTER OF THE HEARING CALLED
BY THE OIL CONSERVATION DIVISION
FOR THE PURPOSE OF CONSIDERING:

CASE NO. 10900

APPLICATION OF H.L. BROWN
TO AMENDED ORDER R-9935 TO APPROVE
AN UNORTHODOX GAS WELL LOCATION,
ROOSEVELT COUNTY, NEW MEXICO.

CERTIFICATE OF MAILING

AND

COMPLIANCE WITH ORDER R-8054

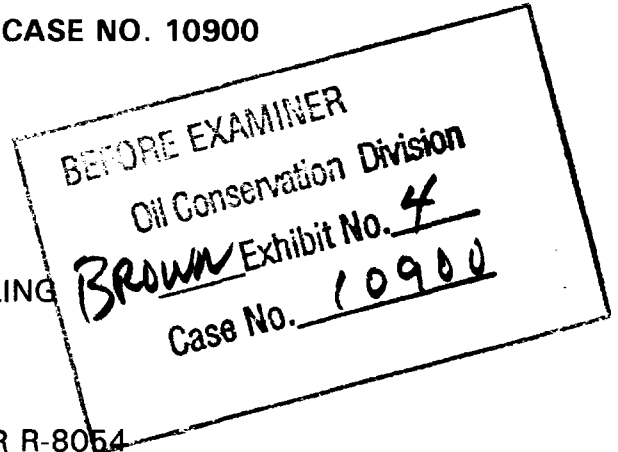

W. THOMAS KELLAHIN, attorney in fact and authorized representative of H. L. Brown, states that the notice provisions of Division Rule 1207 (Order R-8054) have been complied with, that Applicant has caused to be conducted a good faith diligent effort to find the correct addresses of all interested parties entitled to receive notice, that on the 12th day of January 1994, I caused to be mailed by certified mail return-receipt requested notice of this hearing and a copy of the application for the above referenced case along with the cover letter, at least twenty days prior to the hearing set for February 3, 1994, to the parties shown in the application as evidenced by the attached copies of return receipt cards, and that pursuant to Division Rule 1207, notice has been given at the correct addresses provided by such rule.

W. Thomas Kellahin

SUBSCRIBED AND SWORN to before me this 1st day of FEBRUARY, 1994.

Notary Public

My Commission Expires:
June 7, 1994

P. 321 001 092



Receipt for Certified Mail

No Insurance Coverage Provided
Do not use for International Mail
(See Reverse)

Seabrook Corporation
535 17th Street, Suite 1000
Denver, CO 80202-3910

800 June 1991

Domestic Fee	
Special Delivery Fee	
Restricted Delivery Fee	
Return Receipt (showing to Whom & Date Delivered)	
Return Receipt (showing to Whom Date and Addressee's Address)	
TOTAL Postage & Fees	\$
Postmark or Date	

H. L. Brown
01/12/94

Is your RETURN ADDRESS completed on the reverse side?

SENDER:

- Complete items 1 and/or 2 for additional services so that we can
- H. L. Brown
- 01/12/94
- does not permit.
- Write "Return Receipt Requested" on the mailpiece below the article number.
- The Return Receipt will show to whom the article was delivered and the date delivered.

I also wish to receive the following services (for an extra fee):

- Addressee's Address
 - Restricted Delivery
- Consult postmaster for fee.

3. Article Addressed to:
Seabrook Corporation
535 17th Street, Suite 1000
Denver, CO 80202-3910

4a. Article Number
321 001 092

- 4b. Service Type
- Registered
 - Certified
 - Express Mail
 - Insured
 - COD
 - Return Receipt for Merchandise

7. Date of Delivery
1/14/94

5. Signature (Addressee)

8. Addressee's Address (Only if requested and fee is paid)

6. Signature (Agent)

Thank you for using Return Receipt Service.

P 321 001 093



Receipt for Certified Mail

No Insurance Coverage Provided
Do not use for International Mail
(See Reverse)

Sheep Mountain Roayty
Company
P.O. Box 2237
Midland, Texas 79702-2237

Certified Fee	
Special Delivery Fee	
Restricted Delivery Fee	
Return Receipt Showing to Whom & Date Delivered	
Return Receipt Showing to Whom, Date, and Addressee's Address	
TOTAL Postage & Fees	\$
Postmark or Date	

PS Form 3800, June 1991

H. L. Brown
01/12/94

Is your RETURN ADDRESS completed on the reverse side?

SENDER:

• Complete items 1 and/or 2 for additional services

H. L. Brown
01/12/94

so that we can
back if space

I also wish to receive the following services (for an extra fee):

- 1. Addressee's Address
- 2. Restricted Delivery

Consult postmaster for fee.

- Write "Return Receipt Requested" on the mailpiece below the article number.
- The Return Receipt will show to whom the article was delivered and the date delivered.

3. Article Addressed to:

Sheep Mountain Roayty
Company
P.O. Box 2237
Midland, Texas 79702-2237

4a. Article Number
321 001 093

4b. Service Type

Registered Insured
 Certified COD
 Express Mail Return Receipt for Merchandise

7. Date of Delivery
JAN 14 1994

5. Signature (Addressee)

8. Addressee's Address (Only if requested and fee is paid)

6. Signature (Agent)

Thank you for using Return Receipt Service.

P 321 001 087



Receipt for Certified Mail

No Insurance Coverage Provided
Do not use for International Mail
(See Reverse)

R. E. Smith Trust
Ms. Suzanne Benson
Suite 1050
1900 West Loop South
Houston, Texas 77027

Certified Fee	
Special Delivery Fee	
Restricted Delivery Fee	
Return Receipt (Following to Addressee) Fee	
Return Receipt (Following to Date and Address) Fee	
TOTAL POSTAGE & FEES	S
Postmark	

3800 June 1991

H. L. Brown
01/12/94

Is your RETURN ADDRESS completed on the reverse side?

SENDER:

H. L. Brown
01/12/94

- Write "Return Receipt Requested" on the mailpiece below the article number.
- The Return Receipt will show to whom the article was delivered and the date delivered.

so that we can
back if space

I also wish to receive the following services (for an extra fee):

- 1. Addressee's Address
- 2. Restricted Delivery

Consult postmaster for fee.

3. Article Addressed to:
R. E. Smith Trust
Ms. Suzanne Benson
Suite 1050
1900 West Loop South
Houston, Texas 77027

4a. Article Number
321 001 087

4b. Service Type
 Registered Insured
 Certified COD
 Express Mail Return Receipt for Merchandise

7. Date of Delivery
1-14-94

5. Signature (Addressee)
Linda Mosley
6. Signature (Agent)

8. Addressee's Address (Only if requested and fee is paid)

Thank you for using Return Receipt Service.

P 321 001 089



Receipt for Certified Mail

No Insurance Coverage Provided
Do not use for International Mail
(See Reverse)

Minerals Management
Service Royalty
Box 5810
Denver, Co 80217-5810

Postage	
Special Delivery Fee	
Registered Delivery Fee	
Return Receipt (Involving no Address & Date Delivered)	
Additional postage and fee for Return Receipt (Addressed to Addressee in 4 terms)	
Total Postage & Fees	\$
Postmark of Date	

100, June 1991

H. L. Brown
01/12/94

Is your RETURN ADDRESS completed on the reverse side?

SENDER:

- Complete items 1 and/or 2 for additional services.

H. L. Brown

01/12/94

Attach this form to the front of the mailpiece, or on the back if space does not permit.

- Write "Return Receipt Requested" on the mailpiece below the article number.
- The Return Receipt will show to whom the article was delivered and the date delivered.

I also wish to receive the following services (for an extra fee):

- Addressee's Address
- Restricted Delivery

Consult postmaster for fee.

3. Article Addressed to:

Minerals Management
Service Royalty
Box 5810
Denver, Co 80217-5810

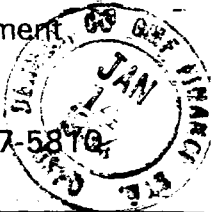

4a. Article Number

321 001 089

4b. Service Type

- Registered Insured
- Certified COD
- Express Mail Return Receipt for Merchandise

7. Date of Delivery

1-14-94

5. Signature (Addressee)

CHAMPION MESSENGER

6. Signature (Agent)

P.O. BOX 6954
DENVER CO 80206

8. Addressee's Address (Only if requested and fee is paid)

Thank you for using Return Receipt Service.

SENDER:
H. L. Brown
01/12/94

I also wish to receive the following services (for an extra fee):
1. Addressee's Address
2. Restricted Delivery
Consult postmaster for fee.

Write "Return Receipt Requested" on the mailpiece below the article number.
The Return Receipt will show to whom the article was delivered and the date delivered.

3. Article Addressed to:
Ronadero Company, Inc
P.O. Box 430
Roswell, NM 88202-0430

4a. Article Number
321 001 094

4b. Service Type
 Registered Insured
 Certified COD
 Express Mail Return Receipt for Merchandise

7. Date of Delivery
1-14-94

5. Signature (Addressee)
[Handwritten Signature]

6. Signature (Agent)

8. Addressee's Address (Only if requested and fee is paid)

PS Form 3811, December 1991 *U.S. GPO: 1992-323-402 **DOMESTIC RETURN RECEIPT**

Is your RETURN ADDRESS completed on the inside?

Thank you for using Return Receipt Service

P 321 001 094



Receipt for Certified Mail

No Insurance Coverage Provided
Do not use for International Mail
(See Reverse)

Ronadero Company, Inc
P.O. Box 430
Roswell, NM 88202-0430

3800, June 1991

Return Receipt Showing to Whom & Date Delivered	
Return Receipt Showing to Whom Date, and Addressee's Address	
TOTAL Postage & Fees	\$
Postmark or Date	

H. L. Brown
01/12/94

321 001 086



Receipt for Certified Mail

No Insurance Coverage Provided
Do not use for international Mail
(See Reverse)

Estate of Vivian L. Smith
Attention: Ms. Suzanne Benson
Suite 1050
1900 West Loop South
Houston, Texas 77027

800, June 1991

Domestic Fee	
Special Delivery Fee	
Restricted Delivery Fee	
Return Receipt (showing to Whom Date Delivered)	
Return Receipt (showing to Whom Date, and Addressee's Address)	
TOTAL Postage & Fees	\$
Postmark (if Date)	

H. L. Brown
01/12/94

Is your RETURN ADDRESS completed on the return side?

SENDER: H. L. Brown 01/12/94		I also wish to receive the following services (for an extra fee): 1. <input type="checkbox"/> Addressee's Address 2. <input type="checkbox"/> Restricted Delivery Consult postmaster for fee.	
3. Article Addressed to: Estate of Vivian L. Smith Attention: Ms. Suzanne Benson Suite 1050 1900 West Loop South Houston, Texas 77027		4a. Article Number 321 001 086	
5. (Signature (Addressee)) <i>Binda Mosley</i>		4b. Service Type <input checked="" type="checkbox"/> Registered <input type="checkbox"/> Insured <input type="checkbox"/> Certified <input checked="" type="checkbox"/> COD <input type="checkbox"/> Express Mail <input checked="" type="checkbox"/> Return Receipt for Merchandise	
6. Signature (Agent)		7. Date of Delivery 1-14-94	
		8. Addressee's Address (Only if requested and fee is paid)	

Thank you for using Return Receipt Service.

P 321 001 090



Receipt for Certified Mail

No Insurance Coverage Provided
Do not use for International Mail
(See Reverse)

B.A. OBrien &
E.O. O'Brien
5461 West Kent Place
Denver, CO 80235-2928

Certified Fee	
Special Delivery Fee	
Restricted Delivery Fee	
Return Receipt Showing to Whom & Date Delivered	
Return Receipt Showing to Whom, Date, and Addressee's Address	
TOTAL Postage & Fees	\$
Postmark or Date	

3800, June 1991

H. L. Brown
01/12/94

Is your RETURN ADDRESS completed on the reverse side?

SENDER:

H. L. Brown
01/12/94

so that we can

I also wish to receive the following services (for an extra fee):

- 1. Addressee's Address
- 2. Restricted Delivery

Consult postmaster for fee.

- Attach this form to the front of the mailpiece, or on the back if space does not permit.
- Write "Return Receipt Requested" on the mailpiece below the article number.
- The Return Receipt will show to whom the article was delivered and the date delivered.

3. Article Addressed to:

B.A. OBrien &
E.O. O'Brien
5461 West Kent Place
Denver, CO 80235-2928

4a. Article Number

321 001 090

4b. Service Type

- Registered Insured
- Certified COD
- Return Receipt for Merchandise

7. Date of Delivery

5. Signature (Addressee)

6. Signature (Agent)

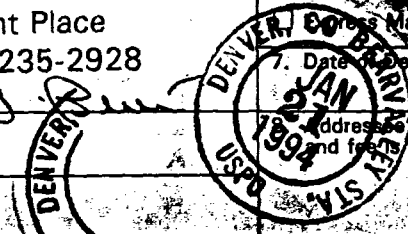

Addressee's Address (Only if requested and fees paid)

Thank you for using Return Receipt Service.

Is your RETURN ADDRESS completed on the reverse side?

SENDER:
 H. L. Brown
 01/12/94

so that we can
back if space

I also wish to receive the following service (for an extra fee):
 1. Addressee's Address
 2. Restricted Delivery
 Consult postmaster for fee.

• Write "Return Receipt Requested" on the mailpiece below the article number.
 • The Return Receipt will show to whom the article was delivered and the date delivered.

3. Article Addressed to:
 James H. Shaw
 2501 Cimmaron
 Midland, Texas 79705-7304

4a. Article Number
 321001 095

4b. Service Type:
 Registered Insured
 Certified COB
 Express Mail Return Receipt for Merchandise

5. Signature (Addressee)
[Signature]

6. Signature (Agent)
[Signature]

7. Date of Delivery
 14 Jan 94

8. Addressee's Address (Only if requested and fee is paid)

PS Form 3811, December 1991 *U.S. GPO: 1992-323-402 **DOMESTIC RETURN RECEIPT**

Thank you for using Return Receipt Service.

P 321 001 095



Receipt for Certified Mail

No Insurance Coverage Provided
 Do not use for International Mail
 See Reverse

James H. Shaw
 2501 Cimmaron
 Midland, Texas 79705-7304

800, June 1991

Return Receipt (When to Whom and Date Delivered)	
Return Receipt (When to Whom Date and Addressee's Address)	
POSTAGE & FEES	\$
Postmark or Date	

H. L. Brown
 01/12/94

Is your RETURN ADDRESS completed on the reverse side?

SENDER:
 H. L. Brown
 01/12/94

I also wish to receive the following services (for an extra fee):

- 1. Addressee's Address
- 2. Restricted Delivery

so that we can
 form to the front of the mailpiece, or on the back if space
 does not permit.
 • Write "Return Receipt Requested" on the mailpiece below the article number.
 • The Return Receipt will show to whom the article was delivered and the date delivered.

Consult postmaster for fee.

3. Article Addressed to:
 Clem E. George
 401 W. Texas, Suite 501.
 Midland, Texas 79701

4a. Article Number
 321 001 084

4b. Service Type
 Registered Insured
 Certified C.O.D.
 Express Mail Return Receipt for Merchandise

7. Date of Delivery
 JAN 18 1994

5. Signature (Addressee)
 Clem E. George
 6. Signature (Agent)

8. Addressee's Address (Only if requested and fee is paid)

PS Form 3811, December 1991 *U.S. GPO: 1992-323-402 **DOMESTIC RETURN RECEIPT**

Thank you for using Return Receipt Service.

P 321 001 084



Receipt for Certified Mail

No Insurance Coverage Provided
 Do not use for International Mail
 See Reverse

Clem E. George
 401 W. Texas, Suite 501.
 Midland, Texas 79701

800, June 1991

Return receipt showing Date of Delivery	
Return receipt showing Date of Delivery	
TOTAL Postage & Fees	\$
Postmark or Date	

H. L. Brown
 01/12/94

P 321 001 088



Receipt for Certified Mail

No Insurance Coverage Provided
Do not use for International Mail
(See Reverse)

Engineer's Trust # 1
P.O. Box 2237
Midland, Texas 79702-2237

1991, June, 100

Certified Fee	
Special Delivery Fee	
Restricted Delivery Fee	
Return Receipt Showing to Whom & Date Delivered	
Return Receipt Showing to Whom, Date, and Addressee's Address	
TOTAL Postage & Fees	\$

Postmark or Date
H. L. Brown
01/12/94

Is your RETURN ADDRESS completed on the reverse side?

SENDER:

Check items 1 and/or 2 for additional services.

H. L. Brown
01/12/94

- Attach this receipt to the mailpiece. This receipt does not permit.
- Write "Return Receipt Requested" on the mailpiece below the article number.
- The Return Receipt will show to whom the article was delivered and the date delivered.

so that we can
return it to you
if space

I also wish to receive the following services (for an extra fee):

- 1. Addressee's Address
- 2. Restricted Delivery

Consult postmaster for fee.

3. Article Addressed to:

Engineer's Trust # 1
P.O. Box 2237
Midland, Texas 79702-2237

4a. Article Number

321 001 088

4b. Service Type

- Registered Insured
- Certified COD
- Express Mail Return Receipt for Merchandise

7. Date of Delivery

JAN 13 1994

5. Signature (Addressee)

6. Signature (Agent)

8. Addressee's Address (Only if requested and fee is paid)

Thank you for using Return Receipt Service.

P 321 001 085



Receipt for Certified Mail

No Insurance Coverage Provided
Do not use for International Mail
(See Reverse)

Betty S. George
c/o Clem E. George
401 W. Texas, Suite 501
Midland, Texas 79701

PS Form 3800, June 1991

Certified Fee	
Special Delivery Fee	
Restricted Delivery Fee	
Return Receipt Involving to Whom & Date Delivered	
Return Receipt Involving to Whom Date, and Addressee's Address	
TOTAL Postage & Fees	\$
Postmark or Date	H. L. Brown 01/12/94

Is your RETURN ADDRESS completed on the reverse side?

SENDER:

• Complete items 1 and/or 2 for additional services

H. L. Brown
01/12/94

so that we can
ack if space

• Write "Return Receipt Requested" on the mailpiece below the article number.
• The Return Receipt will show to whom the article was delivered and the date delivered.

3. Article Addressed to:

Betty S. George
c/o Clem E. George
401 W. Texas, Suite 501
Midland, Texas 79701

4a. Article Number

321 001 085

4b. Service Type

Registered Insured
 Certified COD
 Express Mail Return Receipt for Merchandise

7. Date of Delivery

JAN 18 1994

5. Signature (Addressee)

[Handwritten Signature]

6. Signature (Agent)

8. Addressee's Address (Only if requested and fee is paid)

Thank you for using Return Receipt Service.