

LEGEND

- △ GRAYBURG-SAN ANDRES PRODUCER
- ⊕ SEVEN RIVERS PRODUCER
- ⊙ PENN. PRODUCER
- LOCATION
- ⊙ DRY HOLE
- ⊙ PLUGGED PRODUCER
- ⊙ GRAYBURG-SAN ANDRES INJECTION WELL
- ⊙ GAS INJECTION WELL
- ⊙ ABO PRODUCER

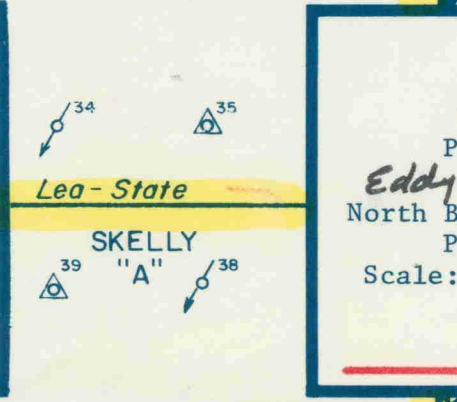

SKELLY OIL COMPANY
 WEST CENTRAL DISTRICT
 LOVINGTON SECONDARY GROUP
 Proposed Lea "C" Waterflood
 Eddy Lea County, New Mexico
 North Basin Geoprovence - Artesia Area
 Program No.: 645-03-04-01
 Scale: 1"=2000' Date: 8-15-73

— Skelly Lea "C" Lease —

Skelly Oil Company

Lea "C" No. 4
1980' FSL 1980' FEL
Section 11 T17S R31E
Eddy County, New Mexico

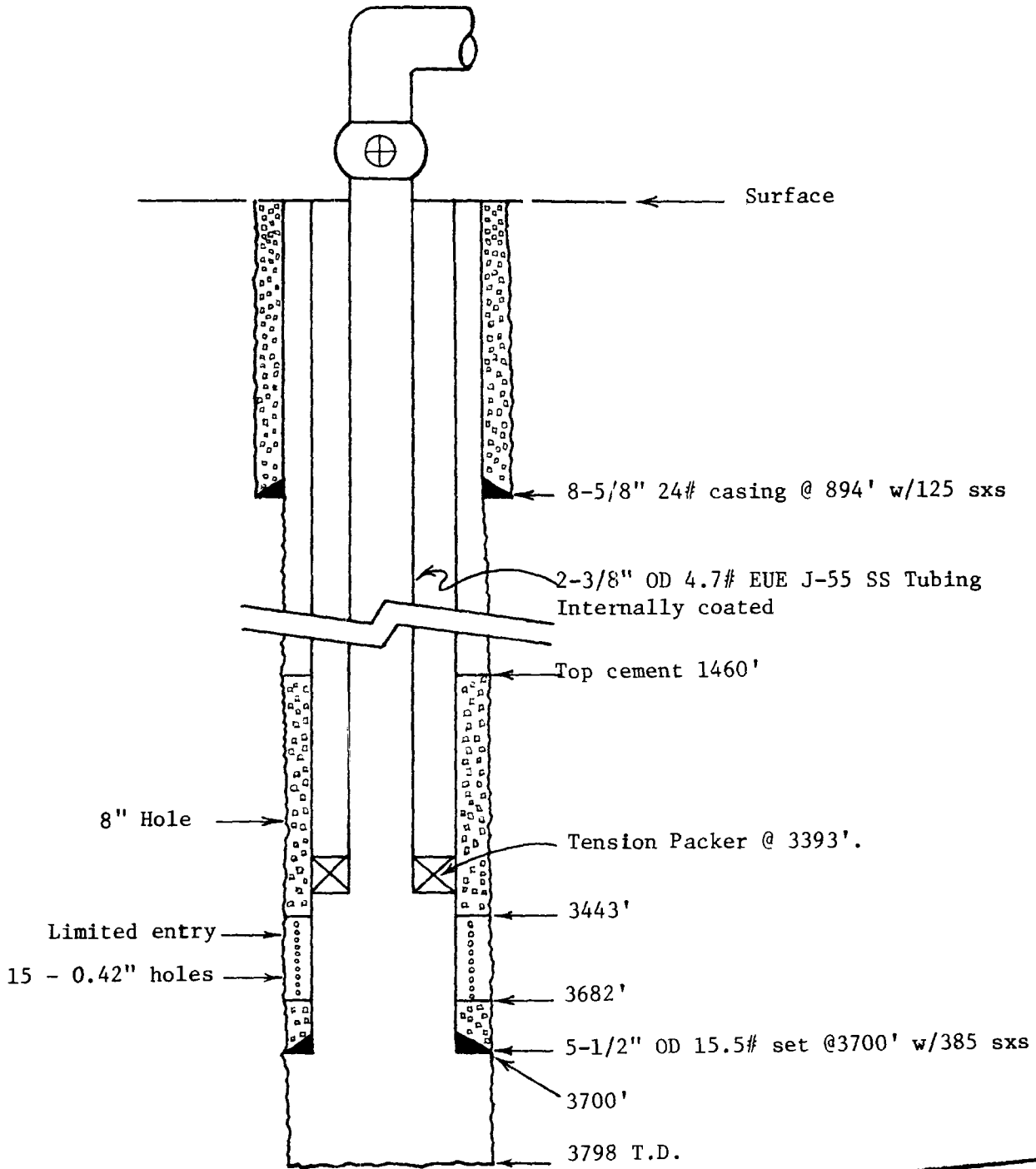

BEFORE EXAMINER NUTTER
OIL CONSERVATION COMMISSION
JK EXHIBIT NO. 5
CASE NO. 5139

Skelly Oil Company

Lea "C" No. 7
1980' FNL 1980' FWL
Section 11 T17S R31E
Eddy County, New Mexico

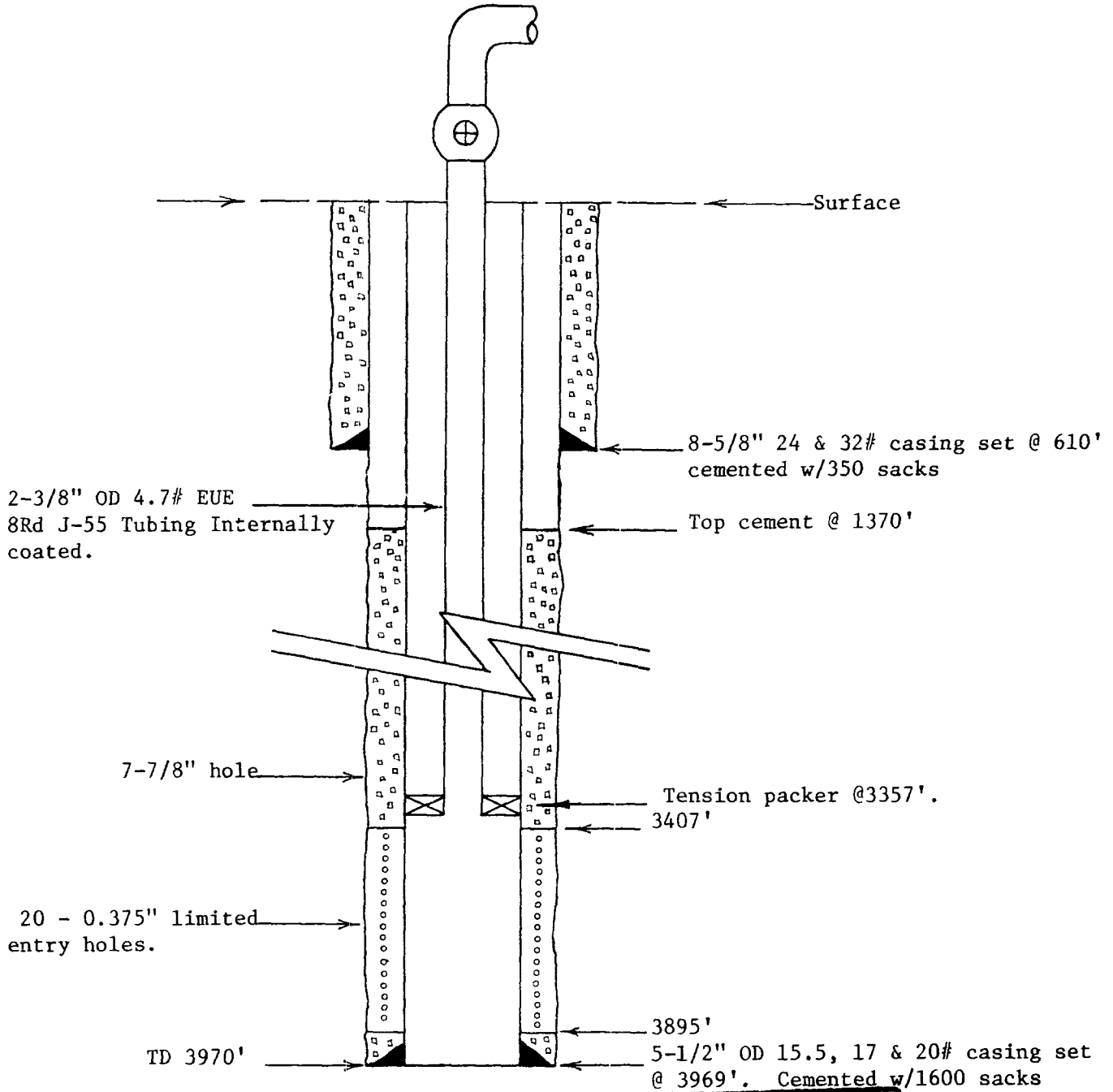

BEFORE EXAMINER NUTTER
OIL CONSERVATION COMMISSION
JR EXHIBIT NO. 6
CASE NO. 5139

Skelly Oil Company

Lea "C" No. 9
660' FSL 1980' FWL
Section 11 T17S R31E
Eddy County, New Mexico

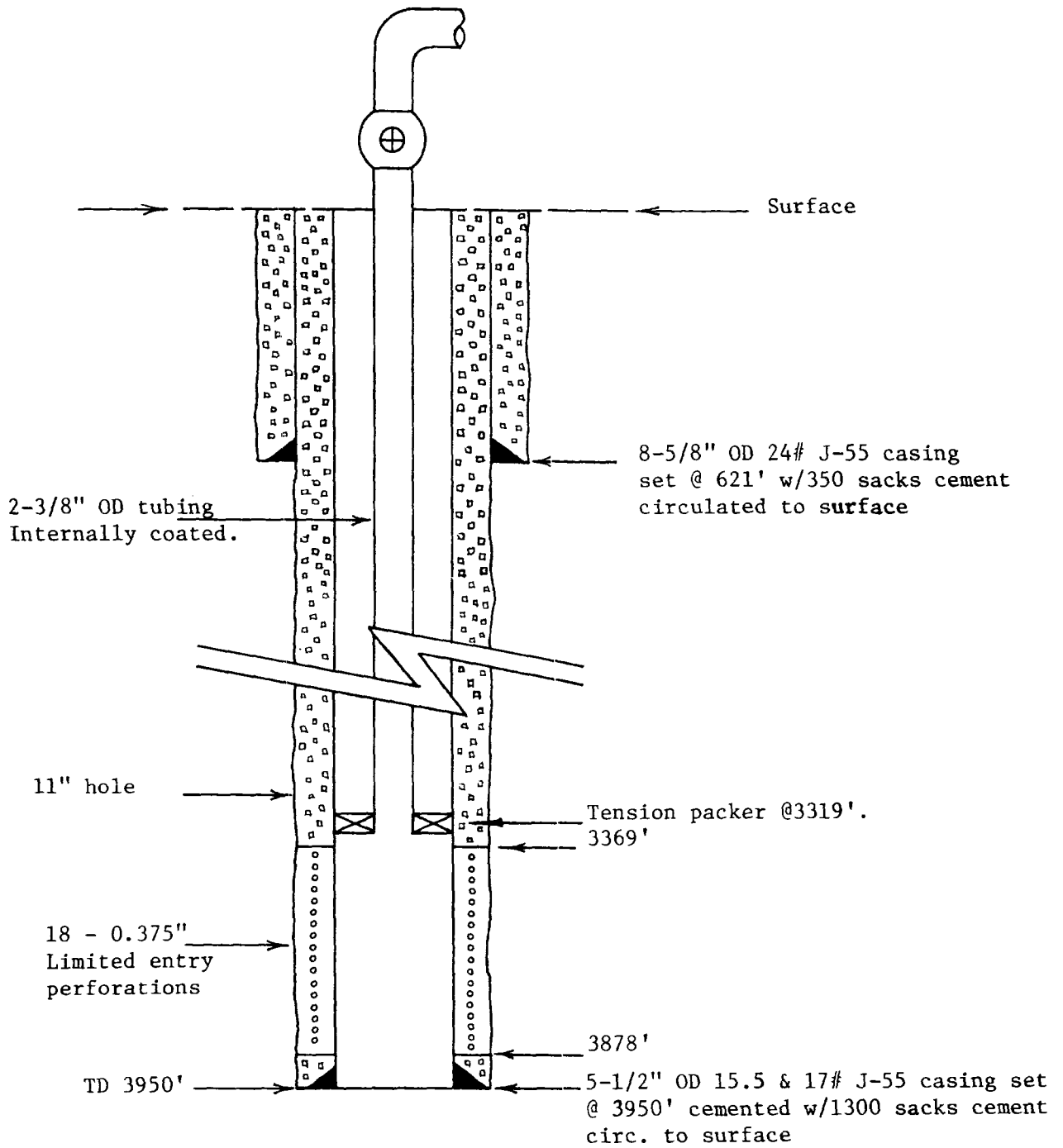

BEFORE EXAMINER NUTTER
OIL CONSERVATION COMMISSION
KR EXHIBIT NO. 7
CASE NO. 5139



WATER ANALYSIS

SAMPLE DESCRIPTION: Water sample from Skelly Unit WF #1 submitted for routine correlation.
 Sample taken 10-2-73.

COMPANY: Skelly Oil Company
 STSR NUMBER: 107330
 REQUESTED BY: Harold Langen

DATE RECEIVED: 10-3-73
 ANALYZED BY: Gene Keil

	<u>Mg/L</u>	<u>Meq/L</u>		
Sodium	55	2.4	pH	6.8
Calcium	73	3.7	Specific Gravity at <u>60</u> °F.	1.0019
Magnesium	4	0.3	Resistivity ohms/m @77°F	10.00
Chloride	34	1.0		<u>Mg/L</u>
Sulfate	142	3.0	Oil Content	
Bicarbonate	151	2.5	Organic Matter	
Carbonate	0	0.0	Hydrogen Sulfide	0.0
Hydroxide	0	0.0	_____	

TOTAL	459		_____	
Dissolved Iron			_____	
Total Iron	0.59	0.0	_____	

WATER PATTERN (Stiff Method)

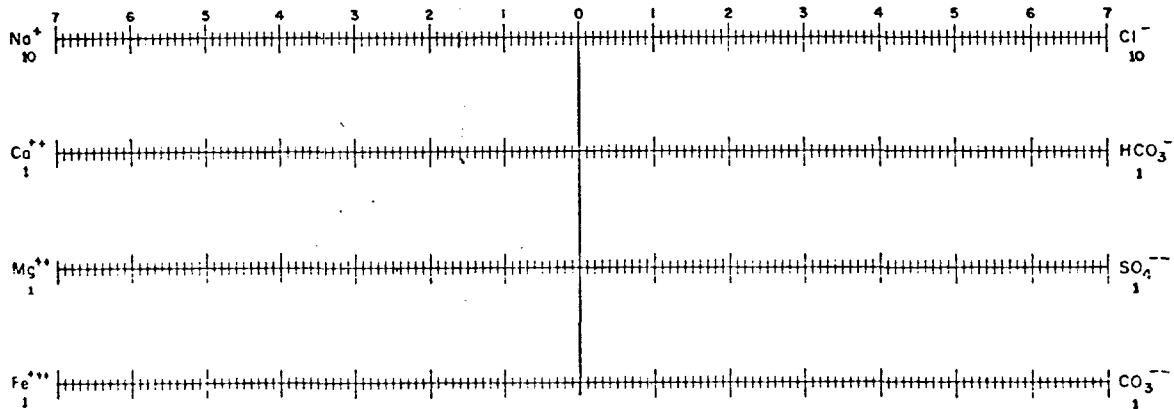

Meq/LITER

Remarks:

BEFORE EXAMINER NUTTER
 OIL CONSERVATION COMMISSION
SK EXHIBIT NO. 8
 CASE NO. 5139

LEGEND

- ▲ GRAYBURG-SAN ANDRES PRODUCER
- ⊙ SEVEN RIVERS PRODUCER
- ⊙ PENN. PRODUCER
- LOCATION
- ◇ DRY HOLE
- ▲ PLUGGED PRODUCER
- ⊙ GRAYBURG-SAN ANDRES INJECTION WELL
- ⊙ GAS INJECTION WELL
- ⊙ ABO PRODUCER

--- Injection Lines
 --- Proposed Injection Lines

ATLANTIC "B"
R-31-E

SKELLY
 U.S. Lea "C"
 REPALLO
 U.S.

U.S. H.E. West
 KERSEY
 MURCHINSON & CLOSUIT "A"
 MURCHINSON & CLOSUIT "B"
 GETTY "AZ"
 KERSEY
 State "WK"

SKELLY "A"
 Dow
 State "WK"

SKELLY "B"
 Lea-State
 State "A"

T 17 S

BEFORE EXAMINER NUTTER
 OIL CONSERVATION COMMISSION
 EXHIBIT NO. 7
 CASE NO. 5-139

SKELLY OIL COMPANY
 WEST CENTRAL DISTRICT
SKELLY UNIT AREA
 EDDY COUNTY, NEW MEXICO

U.S. Dow

U.S. Lynch "B"

Lea U.S.

9