

UNITED STATES
DEPARTMENT OF THE INTERIOR
BUREAU OF LAND MANAGEMENT

NMOC
Artesia

FORM APPROVED
OMB NO. 1004-0137
Expires: January 31, 2018

SUNDRY NOTICES AND REPORTS ON WELLS
Do not use this form for proposals to drill or to re-enter an abandoned well. Use form 3160-3 (APD) for such proposals.

5. Lease Serial No.
NMLC064894

6. If Indian, Allottee or Tribe Name

7. If Unit or CA/Agreement, Name and/or No.
NMNM71016X

8. Well Name and No.
POKER LAKE UNIT 20 BD 122H

9. API Well No.
30-015-45621

10. Field and Pool or Exploratory Area
PURPLE SAGE WOLFCAMP

11. County or Parish, State
EDDY COUNTY, NM

SUBMIT IN TRIPLICATE - Other instructions on page 2

1. Type of Well
 Oil Well Gas Well Other

2. Name of Operator
XTO PERMIAN OPERATING LLC
Contact: KELLY KARDOS
E-Mail: kelly_kardos@xtoenergy.com

3a. Address
6401 HOLIDAY HILL RD BLDG 5
MIDLAND, TX 79707

3b. Phone No. (include area code)
Ph: 432-620-4374

4. Location of Well (Footage, Sec., T., R., M., or Survey Description)
Sec 20 T25S R30E Mer NMP SWSW 330FSL 540FWL

12. CHECK THE APPROPRIATE BOX(ES) TO INDICATE NATURE OF NOTICE, REPORT, OR OTHER DATA

TYPE OF SUBMISSION	TYPE OF ACTION			
<input checked="" type="checkbox"/> Notice of Intent	<input type="checkbox"/> Acidize	<input type="checkbox"/> Deepen	<input type="checkbox"/> Production (Start/Resume)	<input type="checkbox"/> Water Shut-Off
<input type="checkbox"/> Subsequent Report	<input type="checkbox"/> Alter Casing	<input type="checkbox"/> Hydraulic Fracturing	<input type="checkbox"/> Reclamation	<input type="checkbox"/> Well Integrity
<input type="checkbox"/> Final Abandonment Notice	<input type="checkbox"/> Casing Repair	<input type="checkbox"/> New Construction	<input type="checkbox"/> Recomplete	<input checked="" type="checkbox"/> Other
	<input type="checkbox"/> Change Plans	<input type="checkbox"/> Plug and Abandon	<input type="checkbox"/> Temporarily Abandon	Change to Original APD
	<input type="checkbox"/> Convert to Injection	<input type="checkbox"/> Plug Back	<input type="checkbox"/> Water Disposal	

13. Describe Proposed or Completed Operation: Clearly state all pertinent details, including estimated starting date of any proposed work and approximate duration thereof. If the proposal is to deepen directionally or recomplete horizontally, give subsurface locations and measured and true vertical depths of all pertinent markers and zones. Attach the Bond under which the work will be performed or provide the Bond No. on file with BLM/BIA. Required subsequent reports must be filed within 30 days following completion of the involved operations. If the operation results in a multiple completion or recompletion in a new interval, a Form 3160-4 must be filed once testing has been completed. Final Abandonment Notices must be filed only after all requirements, including reclamation, have been completed and the operator has determined that the site is ready for final inspection.

XTO Permian Operating, LLC requests permission to make the following changes to the original APD:

Change the casing design from a 3-string design to a 4-string design per the attached drilling program.

XTO requests to utilize centralizers only in the curve after the KOP and only a minimum of one every other joint.

Request to batch drill was approved ON 5/29/19 (WIS: 466284).

NM OIL CONSERVATION
ARTESIA DISTRICT

AUG 21 2019

RECEIVED

SEE ATTACHED FOR
CONDITIONS OF APPROVAL

14. I hereby certify that the foregoing is true and correct.
Electronic Submission #475507 verified by the BLM Well Information System
For XTO PERMIAN OPERATING LLC, sent to the Carlsbad
Committed to AFMSS for processing by PRISCILLA PEREZ on 07/29/2019 ()

Name (Printed/Typed) KELLY KARDOS Title REGULATORY COORDINATOR
APPROVED

Signature (Electronic Submission) Date 07/29/2019

THIS SPACE FOR FEDERAL OR STATE OFFICIAL USE 7 2019

Approved By _____ Title BUREAU OF LAND MANAGEMENT Date _____
ROSWELL FIELD OFFICE
Office

Conditions of approval, if any, are attached. Approval of this notice does not warrant or certify that the applicant holds legal or equitable title to those rights in the subject lease which would entitle the applicant to conduct operations thereon.

Title 18 U.S.C. Section 1001 and Title 43 U.S.C. Section 1212 make it a crime for any person knowingly and willfully to make to any department or agency of the United States any false, fictitious or fraudulent statements or representations as to any matter within its jurisdiction.

(Instructions on page 2)

**** OPERATOR-SUBMITTED ** OPERATOR-SUBMITTED ** OPERATOR-SUBMITTED ****

Rwp 10-29-19

District I
1625 N. French Dr., Hobbs, NM 88240
Phone: (575) 393-6161 Fax: (575) 393-0720
District II
811 S. First St., Artesia, NM 88210
Phone: (575) 748-1283 Fax: (575) 748-9720
District III
1000 Rio Brazos Road, Aztec, NM 87410
Phone: (505) 334-6178 Fax: (505) 334-6170
District IV
1220 S. St. Francis Dr., Santa Fe, NM 87505
Phone: (505) 476-3460 Fax: (505) 476-3462

NM OIL CONSERVATION
ARTESIA DISTRICT

Form C-102
Revised August 1, 2011

State of New Mexico
Energy, Minerals & Natural Resources Department
OIL CONSERVATION DIVISION
1220 South St. Francis Dr.
Santa Fe, NM 87505

Submit one copy to appropriate District Office

RECEIVED

AMENDED REPORT

WELL LOCATION AND ACREAGE DEDICATION PLAT

¹ API Number 30-015 -45621	² Pool Code 98220	³ Pool Name PURPLE SAGE; WOLFCAMP
⁴ Property Code	⁵ Property Name POKER LAKE UNIT 20 BD	
⁷ OGRID No. 373075	⁸ Operator Name XTO PERMIAN OPERATING, LLC	
		⁶ Well Number 122H
		⁹ Elevation 3,158'

¹⁰ Surface Location

UL or lot no.	Section	Township	Range	Lot Idn	Feet from the	North/South line	Feet from the	East/West line	County
M	20	25 S	30 E		330	SOUTH	540	WEST	EDDY

¹¹ Bottom Hole Location If Different From Surface

UL or lot no.	Section	Township	Range	Lot Idn	Feet from the	North/South line	Feet from the	East/West line	County
M	32	25 S	30 E		200	SOUTH	990	WEST	EDDY

¹² Dedicated Acres 640	¹³ Joint or Infill	¹⁴ Consolidation Code	¹⁵ Order No.
--------------------------------------	-------------------------------	----------------------------------	-------------------------

No allowable will be assigned to this completion until all interests have been consolidated or a non-standard unit has been approved by the division.

¹⁶

<p>GEODETIC COORDINATES NAD 27 NME SURFACE LOCATION Y= 403,645.7 X= 631,125.3 LAT.= 32.109030°N LONG.= 103.908841°W</p> <p>FIRST TAKE POINT NAD 27 NME Y= 402,991.0 X= 631,578.7 LAT.= 32.107226°N LONG.= 103.908385°W</p> <p>CORNER COORDINATES TABLE NAD 27 NME</p> <table style="font-size: small;"> <tr><td>A - Y= 403,309.4 N, X= 630,586.8 E</td></tr> <tr><td>B - Y= 403,325.1 N, X= 631,923.1 E</td></tr> <tr><td>C - Y= 400,654.5 N, X= 630,604.6 E</td></tr> <tr><td>D - Y= 400,669.1 N, X= 631,940.0 E</td></tr> <tr><td>E - Y= 397,997.0 N, X= 630,622.4 E</td></tr> <tr><td>F - Y= 398,011.2 N, X= 631,958.0 E</td></tr> <tr><td>G - Y= 395,341.8 N, X= 630,625.3 E</td></tr> <tr><td>H - Y= 395,354.2 N, X= 631,958.0 E</td></tr> <tr><td>I - Y= 392,687.0 N, X= 630,628.7 E</td></tr> <tr><td>J - Y= 392,697.7 N, X= 631,958.4 E</td></tr> </table> <p>CORNER COORDINATES TABLE NAD 83 NME</p> <table style="font-size: small;"> <tr><td>A - Y= 403,367.5 N, X= 671,771.7 E</td></tr> <tr><td>B - Y= 403,383.2 N, X= 673,108.1 E</td></tr> <tr><td>C - Y= 400,712.5 N, X= 671,789.6 E</td></tr> <tr><td>D - Y= 400,727.1 N, X= 673,125.0 E</td></tr> <tr><td>E - Y= 398,055.0 N, X= 671,807.5 E</td></tr> <tr><td>F - Y= 398,069.2 N, X= 673,143.1 E</td></tr> <tr><td>G - Y= 395,399.7 N, X= 671,810.5 E</td></tr> <tr><td>H - Y= 395,412.1 N, X= 673,143.2 E</td></tr> <tr><td>I - Y= 392,744.9 N, X= 671,814.0 E</td></tr> <tr><td>J - Y= 392,755.6 N, X= 673,143.7 E</td></tr> </table> <p>LAST TAKE POINT NAD 27 NME Y= 393,025.0 X= 631,618.3 LAT.= 32.079829°N LONG.= 103.908384°W</p> <p>BOTTOM HOLE LOCATION NAD 27 NME Y= 392,895.0 X= 631,618.5 LAT.= 32.079471°N LONG.= 103.908385°W</p>	A - Y= 403,309.4 N, X= 630,586.8 E	B - Y= 403,325.1 N, X= 631,923.1 E	C - Y= 400,654.5 N, X= 630,604.6 E	D - Y= 400,669.1 N, X= 631,940.0 E	E - Y= 397,997.0 N, X= 630,622.4 E	F - Y= 398,011.2 N, X= 631,958.0 E	G - Y= 395,341.8 N, X= 630,625.3 E	H - Y= 395,354.2 N, X= 631,958.0 E	I - Y= 392,687.0 N, X= 630,628.7 E	J - Y= 392,697.7 N, X= 631,958.4 E	A - Y= 403,367.5 N, X= 671,771.7 E	B - Y= 403,383.2 N, X= 673,108.1 E	C - Y= 400,712.5 N, X= 671,789.6 E	D - Y= 400,727.1 N, X= 673,125.0 E	E - Y= 398,055.0 N, X= 671,807.5 E	F - Y= 398,069.2 N, X= 673,143.1 E	G - Y= 395,399.7 N, X= 671,810.5 E	H - Y= 395,412.1 N, X= 673,143.2 E	I - Y= 392,744.9 N, X= 671,814.0 E	J - Y= 392,755.6 N, X= 673,143.7 E	<p>GEODETIC COORDINATES NAD 83 NME SURFACE LOCATION Y= 403,703.8 X= 672,310.2 LAT.= 32.109155°N LONG.= 103.910324°W</p> <p>FIRST TAKE POINT NAD 83 NME Y= 403,049.1 X= 672,763.7 LAT.= 32.107350°N LONG.= 103.908868°W</p> <p>CORNER COORDINATES TABLE NAD 83 NME</p> <table style="font-size: small;"> <tr><td>A - Y= 403,367.5 N, X= 671,771.7 E</td></tr> <tr><td>B - Y= 403,383.2 N, X= 673,108.1 E</td></tr> <tr><td>C - Y= 400,712.5 N, X= 671,789.6 E</td></tr> <tr><td>D - Y= 400,727.1 N, X= 673,125.0 E</td></tr> <tr><td>E - Y= 398,055.0 N, X= 671,807.5 E</td></tr> <tr><td>F - Y= 398,069.2 N, X= 673,143.1 E</td></tr> <tr><td>G - Y= 395,399.7 N, X= 671,810.5 E</td></tr> <tr><td>H - Y= 395,412.1 N, X= 673,143.2 E</td></tr> <tr><td>I - Y= 392,744.9 N, X= 671,814.0 E</td></tr> <tr><td>J - Y= 392,755.6 N, X= 673,143.7 E</td></tr> </table> <p>LAST TAKE POINT NAD 83 NME Y= 393,082.9 X= 672,803.6 LAT.= 32.079954°N LONG.= 103.908866°W</p> <p>BOTTOM HOLE LOCATION NAD 83 NME Y= 392,952.9 X= 672,803.8 LAT.= 32.079596°N LONG.= 103.908867°W</p>	A - Y= 403,367.5 N, X= 671,771.7 E	B - Y= 403,383.2 N, X= 673,108.1 E	C - Y= 400,712.5 N, X= 671,789.6 E	D - Y= 400,727.1 N, X= 673,125.0 E	E - Y= 398,055.0 N, X= 671,807.5 E	F - Y= 398,069.2 N, X= 673,143.1 E	G - Y= 395,399.7 N, X= 671,810.5 E	H - Y= 395,412.1 N, X= 673,143.2 E	I - Y= 392,744.9 N, X= 671,814.0 E	J - Y= 392,755.6 N, X= 673,143.7 E
A - Y= 403,309.4 N, X= 630,586.8 E																															
B - Y= 403,325.1 N, X= 631,923.1 E																															
C - Y= 400,654.5 N, X= 630,604.6 E																															
D - Y= 400,669.1 N, X= 631,940.0 E																															
E - Y= 397,997.0 N, X= 630,622.4 E																															
F - Y= 398,011.2 N, X= 631,958.0 E																															
G - Y= 395,341.8 N, X= 630,625.3 E																															
H - Y= 395,354.2 N, X= 631,958.0 E																															
I - Y= 392,687.0 N, X= 630,628.7 E																															
J - Y= 392,697.7 N, X= 631,958.4 E																															
A - Y= 403,367.5 N, X= 671,771.7 E																															
B - Y= 403,383.2 N, X= 673,108.1 E																															
C - Y= 400,712.5 N, X= 671,789.6 E																															
D - Y= 400,727.1 N, X= 673,125.0 E																															
E - Y= 398,055.0 N, X= 671,807.5 E																															
F - Y= 398,069.2 N, X= 673,143.1 E																															
G - Y= 395,399.7 N, X= 671,810.5 E																															
H - Y= 395,412.1 N, X= 673,143.2 E																															
I - Y= 392,744.9 N, X= 671,814.0 E																															
J - Y= 392,755.6 N, X= 673,143.7 E																															
A - Y= 403,367.5 N, X= 671,771.7 E																															
B - Y= 403,383.2 N, X= 673,108.1 E																															
C - Y= 400,712.5 N, X= 671,789.6 E																															
D - Y= 400,727.1 N, X= 673,125.0 E																															
E - Y= 398,055.0 N, X= 671,807.5 E																															
F - Y= 398,069.2 N, X= 673,143.1 E																															
G - Y= 395,399.7 N, X= 671,810.5 E																															
H - Y= 395,412.1 N, X= 673,143.2 E																															
I - Y= 392,744.9 N, X= 671,814.0 E																															
J - Y= 392,755.6 N, X= 673,143.7 E																															

¹⁷ OPERATOR CERTIFICATION

I hereby certify that the information contained herein is true and complete to the best of my knowledge and belief, and that this organization either owns a working interest or unleased mineral interest in the land including the proposed bottom hole location or has a right to drill this well at this location pursuant to a contract with an owner of such a mineral or working interest, or to a voluntary pooling agreement or a compulsory pooling order heretofore entered by the division.

Kelly Kardos 7/26/19

Signature Date

Kelly Kardos

Printed Name

kelly_kardos@xtoenergy.com

E-mail Address

¹⁸ SURVEYOR CERTIFICATION

I hereby certify that the well location shown on this plat was plotted from field notes of actual surveys made by me or under my supervision, and that the same is true and correct to the best of my belief.

4-5-2019

Date of Survey

Signature and Seal of Professional Surveyor:

MARK DILLON HARP 23786

Certificate Number RR: 2017071045

NM OIL CONSERVATION

ARTESIA DISTRICT

AUG 21 2019

Intent As Drilled

API #
30-015-45621

RECEIVED

Operator Name: XTO Permian Operating, LLC	Property Name: Poker Lake Unit 20 BD	Well Number 701H
--	---	---------------------

Kick Off Point (KOP)

UL M	Section 20	Township 25S	Range 30E	Lot	Feet 330	From N/S South	Feet 540	From E/W West	County Eddy
Latitude 32.109155					Longitude -103.910324			NAD NAD83	

First Take Point (FTP)

UL D	Section 29	Township 25S	Range 30E	Lot	Feet 330	From N/S North	Feet 990	From E/W West	County Eddy
Latitude 32.107350					Longitude -103.908868			NAD NAD83	

Last Take Point (LTP)

UL M	Section 32	Township 25S	Range 30E	Lot	Feet 330	From N/S South	Feet 990	From E/W West	County Eddy
Latitude 32.079954					Longitude -103.908868			NAD NAD83	

Is this well the defining well for the Horizontal Spacing Unit? N

Is this well an infill well? Y

If infill is yes please provide API if available, Operator Name and well number for Defining well for Horizontal Spacing Unit.

API #	Operator Name: XTO Permian Operating, LLC	Property Name: Poker Lake Unit 20 BD	Well Number 701H
-------	--	---	---------------------

KZ 06/29/2018

DRILLING PLAN: BLM COMPLIANCE
(Supplement to BLM 3160-3)

XTO Energy Inc.
PLU 20 Brushy Draw 122H
Projected TD: 21758' MD / 11131' TVD
SHL: 330' FSL & 540' FWL , Section 20, T25S, R30E
BHL: 200' FSL & 990' FWL , Section 32, T25S, R30E
Eddy County, NM

1. Geologic Name of Surface Formation
A. Quaternary

2. Estimated Tops of Geological Markers & Depths of Anticipated Fresh Water, Oil or Gas:

Formation	Well Depth (TVD)	Water/Oil/Gas
Rustler	609'	Water
Top of Salt	696'	Water
Base of Salt	3397'	Water
Delaware	3587'	Water
Bone Spring	7433'	Water/Oil/Gas
1st Bone Spring Ss	8378'	Water/Oil/Gas
2nd Bone Spring Ss	9200'	Water/Oil/Gas
3rd Bone Spring Ss	10289'	Water/Oil/Gas
3rd Bone Spring Sh Lwr	10133'	Water/Oil/Gas
Wolfcamp A	10818'	Water/Oil/Gas
Wolfcamp A Lwr	10999'	Water/Oil/Gas
Target/Land Curve	11131'	Water/Oil/Gas

- *** Hydrocarbons @ Brushy Canyon
- *** Groundwater depth 40' (per NM State Engineers Office).

No other formations are expected to yield oil, gas or fresh water in measurable volumes. The surface fresh water sands will be protected by setting 16 inch casing @ 640' (56' above the salt) and circulating cement back to surface. The salt will be isolated by setting 11-3/4 inch casing at 3440' and circulating cement to surface. 8-5/8 inch intermediate casing will be set at 10210'. An 7-7/8 inch curve and 7-7/8 inch lateral hole will be drilled to TD, where 5-1/2 inch casing will be set and cemented back up to the 9-5/8 inch casing shoe.

3. Casing Design

36 45' see COAS

Hole Size	Depth	OD Csg	Weight	Collar	Grade	New/Used	SF Burst	SF Collapse	SF Tension
20"	0' - 640'	16"	75	STC	J-55	New	2.46	4.56	24.54
14-3/4"	0' - 3440'	11-3/4"	47	STC	J-55	New	1.08	1.40	4.56
10-5/8"	0' - 10210'	8-5/8"	32	LTC	HCL-80	New	1.57	1.32	2.24
7-7/8"	0' - 21758'	5-1/2"	20	BTC	P-110	New	1.30	1.83	2.11

- XTO requests to utilize centralizers only in the curve after the KOP and only a minimum of one every other joint.
- 16" Collapse analyzed using 75% evacuation. Casing to be filled while running.
- 11-3/4" & 8-5/8" Collapse analyzed using 50% evacuation based on regional experience.
- 5-1/2" tension calculated using vertical hanging weight plus the lateral weight multiplied by a friction factor of 0.35

WELLHEAD:

Temporary Wellhead

- 16" SOW bottom x 21-1/4" 2M top flange.

Permanent Wellhead - GE RSH Multibowl System

- A. Starting Head: 13-5/8" 5M top flange x 11-3/4" SOW bottom
- B. Tubing Head: 13-5/8" 5M bottom flange x 7" 10M top flange
 - Wellhead will be installed by manufacturer's representatives.
 - Manufacturer will monitor welding process to ensure appropriate temperature of seal.
 - Operator will test the 8-5/8" casing per BLM Onshore Order 2

- Wellhead manufacturer representative will not be present for BOP test plug installation

4. Cement Program

Surface Casing: 16", 75 New J-55, STC casing to be set at +/- 640'

Lead: 1450 sxs EconoCem-HLTRRC (mixed at 12.9 ppg, 1.87 ft³/sx, 10.13 gal/sx water)
Tail: 190 sxs Halcem-C + 2% CaCl (mixed at 14.8 ppg, 1.35 ft³/sx, 6.39 gal/sx water)
Compressives: 12-hr = 900 psi 24 hr = 1500 psi

1st Intermediate Casing: 11-3/4", 47 New J-55, STC casing to be set at +/- 3440'

Lead: 1450 sxs EconoCem-HLTRRC (mixed at 12.9 ppg, 1.87 ft³/sx, 10.13 gal/sx water)
Tail: 190 sxs Halcem-C + 2% CaCl (mixed at 14.8 ppg, 1.35 ft³/sx, 6.39 gal/sx water)
Compressives: 12-hr = 900 psi 24 hr = 1500 psi

2nd Intermediate Casing: 8-5/8", 32 New HCL-80, LTC casing to be set at +/- 10210'

ECP/DV Tool to be set at 3540'

1st Stage

Lead: 1370 sxs Halcem-C + 2% CaCl (mixed at 12.9 ppg, 1.88 ft³/sx, 9.61 gal/sx water)

Tail: 150 sxs Halcem-C + 2% CaCl (mixed at 14.8 ppg, 1.33 ft³/sx, 6.39 gal/sx water)
Compressives: 12-hr = 900 psi 24 hr = 1500 psi

2nd Stage

Lead: 670 sxs Halcem-C + 2% CaCl (mixed at 12.9 ppg, 1.88 ft³/sx, 9.61 gal/sx water)

Tail: 150 sxs Halcem-C + 2% CaCl (mixed at 14.8 ppg, 1.33 ft³/sx, 6.39 gal/sx water)
Compressives: 12-hr = 900 psi 24 hr = 1500 psi

Production Casing: 5-1/2", 20 New P-110, BTC casing to be set at +/- 21758'

Tail: 1650 sxs VersaCem (mixed at 13.2 ppg, 1.61 ft³/sx, 8.38 gal/sx water)
Compressives: 12-hr = 1375 psi 24 hr = 2285 psi

XTO requests a variance to be able to batch drill these wells if necessary. In doing so, XTO will set 11-3/4" intermediate casing and ensure that the well is cemented properly and the well is dead. With floats holding, no pressure on the intermediate csg annulus, and the installation of a TA cap as per GE recommendations, XTO will contact the BLM to skid the rig to drill the surface and intermediate for the remaining wells on the pad. Once surface and intermediate are all completed, XTO will begin drilling the production hole on each of the wells. Batch drill approved on 5/29/29 (WIS: 466444).

5. Pressure Control Equipment

The blow out preventer equipment (BOP) on surface casing/temp. wellhead will consist of a 21-1/4" minimum 2M Hydril. MASP should not exceed 1068 psi.

Once the permanent WH is installed on the 13-3/8 casing, the blow out preventer equipment (BOP) will consist of a 13-5/8" minimum 5M Hydril and a 13-5/8" minimum 5M 3-Ram BOP. MASP should not exceed 3629 psi. In any instance where 10M BOP is required by BLM, XTO requests a variance to utilize 5M annular with 10M ram preventers (a common BOP configuration, which allows use of 10M rams in unlikely event that pressures exceed 5M).

All BOP testing will be done by an independent service company. Annular pressure tests will be limited to 50% of the working pressure. When nipping up on the 13-5/8" 5M bradenhead and flange, the BOP test will be limited to 5000 psi. Since a multibowl system will be used, subsequent BOP pressure tests will be performed as necessary based on required testing schedule (i.e., at least every 30 days). All BOP tests will include a low pressure test as per BLM regulations. The 5M BOP diagrams are attached. Blind rams will be functioned tested each trip, pipe rams will be functioned tested each day.

A variance is requested to allow use of a flex hose as the choke line from the BOP to the Choke Manifold. If this hose is used, a copy of the manufacturer's certification and pressure test chart will be kept on the rig. Attached is an example of a certification and pressure test chart. The manufacturer does not require anchors.

3695' 150' below previous shoe) See COAS.

see (OAS)

6. Proposed Mud Circulation System

INTERVAL	Hole Size	Mud Type	MW (ppg)	Viscosity (sec/qt)	Fluid Loss (cc)
0' - 640'	18-1/2"	FW/Native	8.4-9.0	45-60	NC
640' - 3440'	14-3/4"	Brine / OBM	9.0-10.2	30-32	NC
3440' to 10210'	10-5/8"	FW/Cut Brine	8.7-10.0	30-32	NC
10210' to 21758'	7-7/8"	FW / Cut Brine / Polymer / OBM	10.1 - 10.9	29-32	NC - 20

The necessary mud products for weight addition and fluid loss control will be on location at all times.

Spud with fresh water/native mud. Drill out from under 16" surface casing with brine solution. A 9.0ppg-10.2ppg brine mud will be used while drilling through the salt formation. Use fibrous materials as needed to control seepage and lost circulation. Pump viscous sweeps as needed for hole cleaning. Pump speed will be recorded on a daily drilling report after mudding up. A Pason or Totco will be used to detect changes in loss or gain of mud volume. A mud test will be performed every 24 hours to determine: density, viscosity, strength, filtration and pH as necessary. Use available solids controls equipment to help keep mud weight down after mud up. Rig up solids control equipment to operate as a closed loop system.



GE Oil & Gas

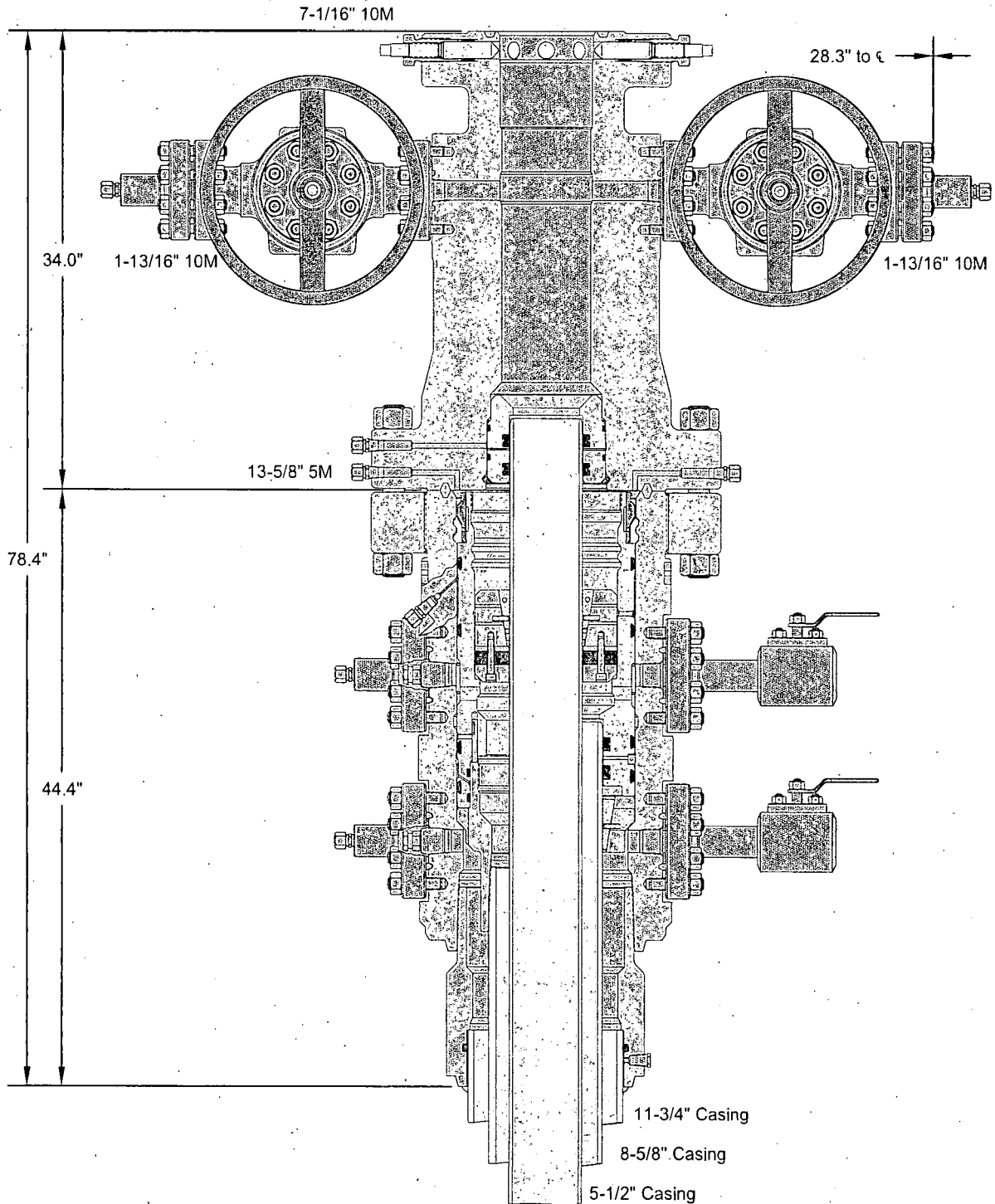

ALL DIMENSIONS ARE APPROXIMATE

This drawing is the property of GE Oil & Gas Pressure Control LP and is considered confidential. Unless otherwise approved in writing, neither it nor its contents may be used, copied, transmitted or reproduced except for the sole purpose of GE Oil & Gas Pressure Control LP.

XTO ENERGY, INC.

11-3/4" x 8-5/8" x 5-1/2" 10M.RSH-2 Wellhead
Assembly, With T-EBS-F Tubing Head

DRAWN VJK 31OCT16

APPRV KN 31OCT16

FOR REFERENCE ONLY

DRAWING NO. 10012358

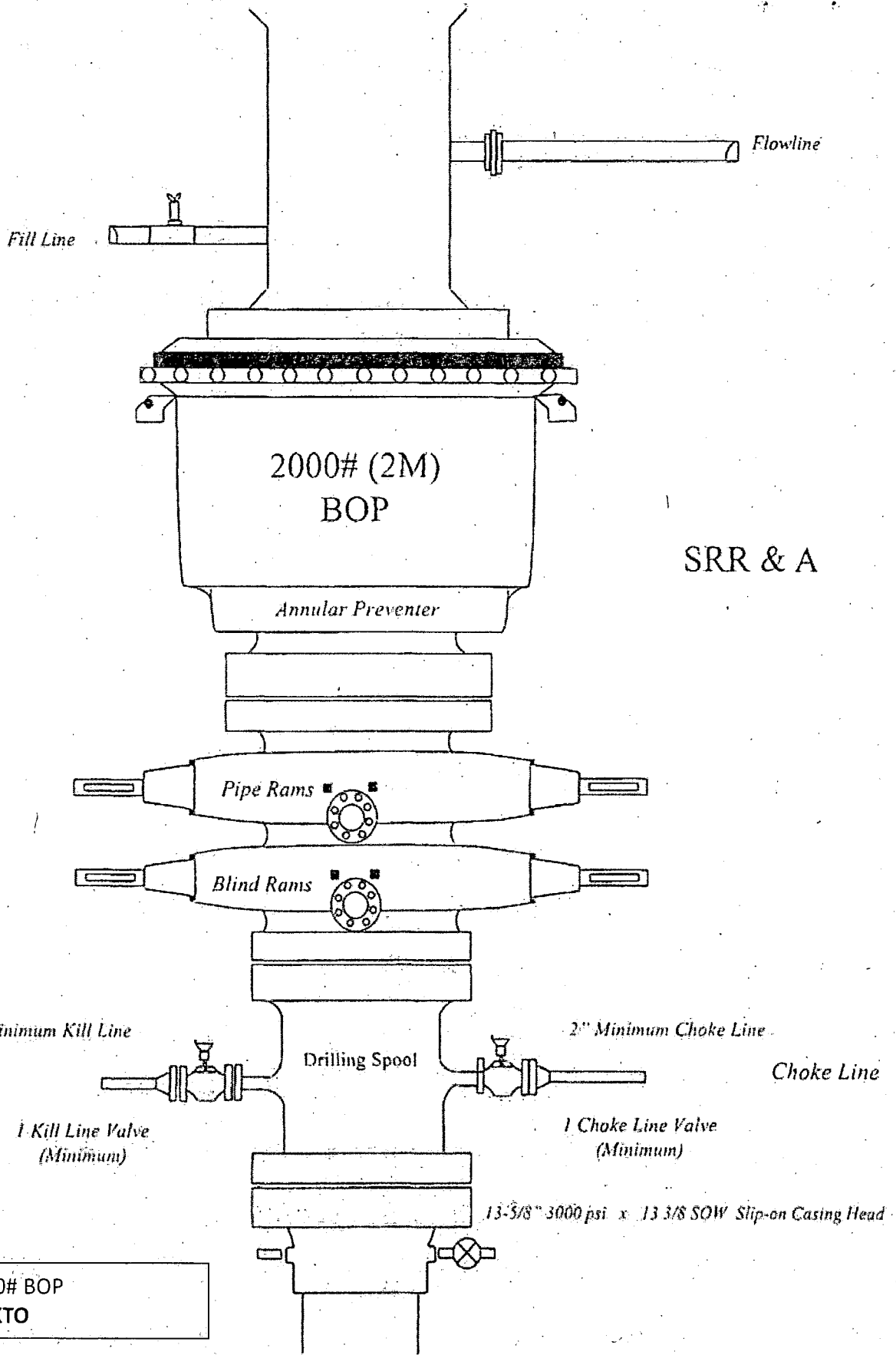

SRR & A

2000# BOP
XTO

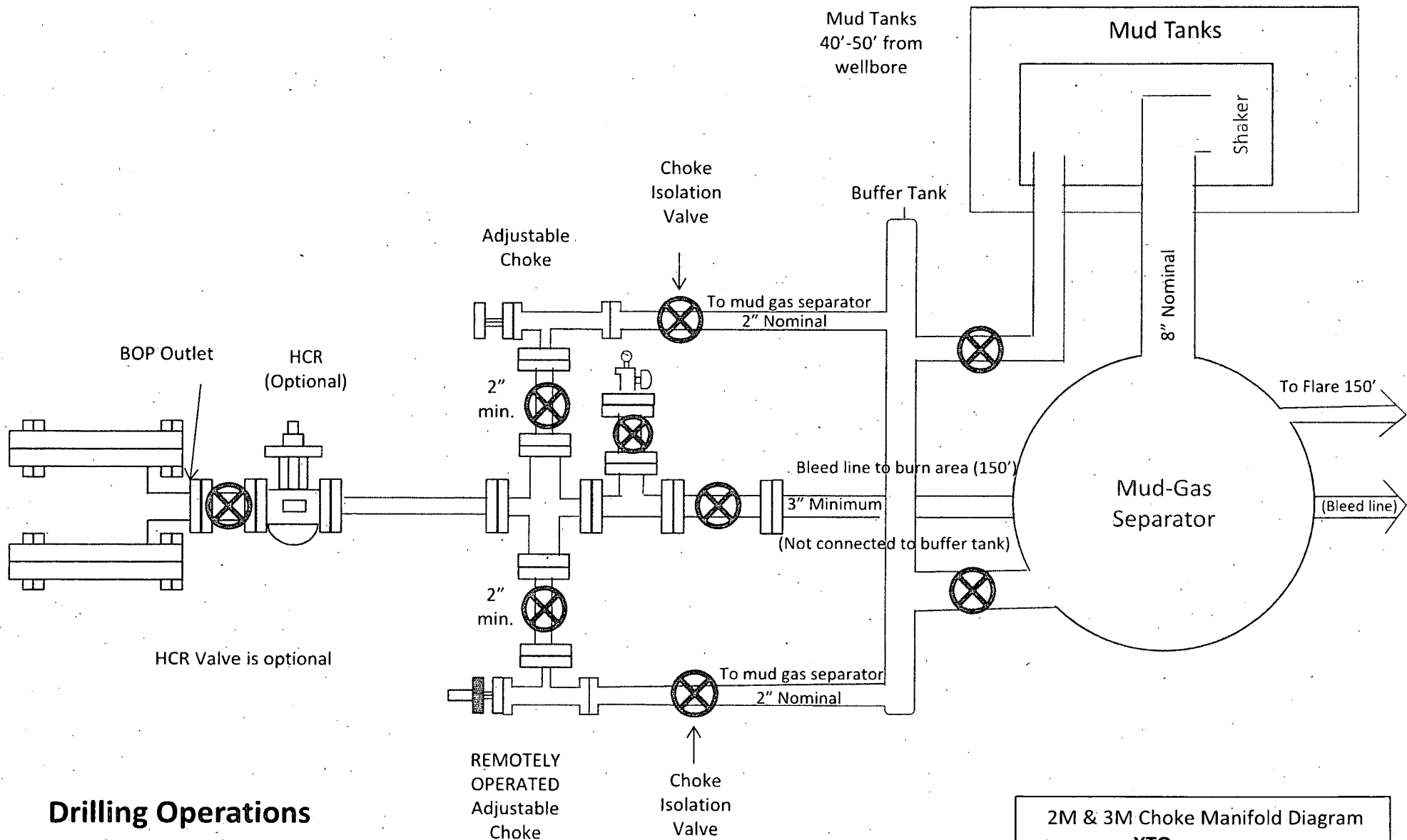

**Drilling Operations
Choke Manifold
2M & 3M Service**

**2M & 3M Choke Manifold Diagram
XTO**

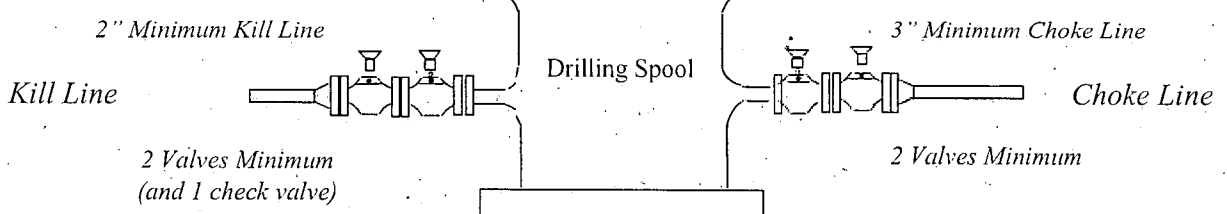
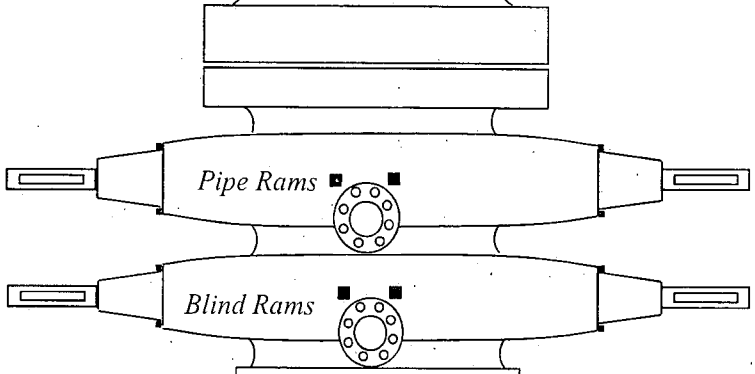
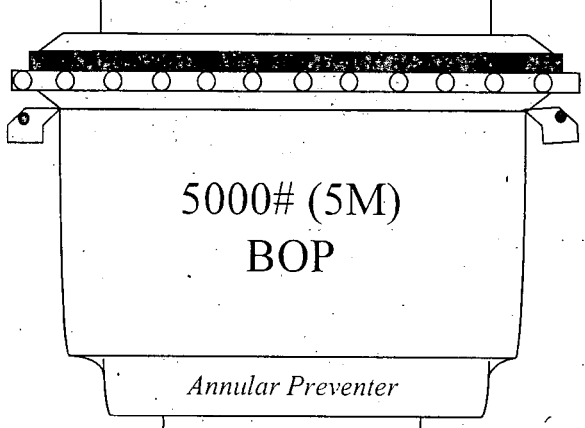
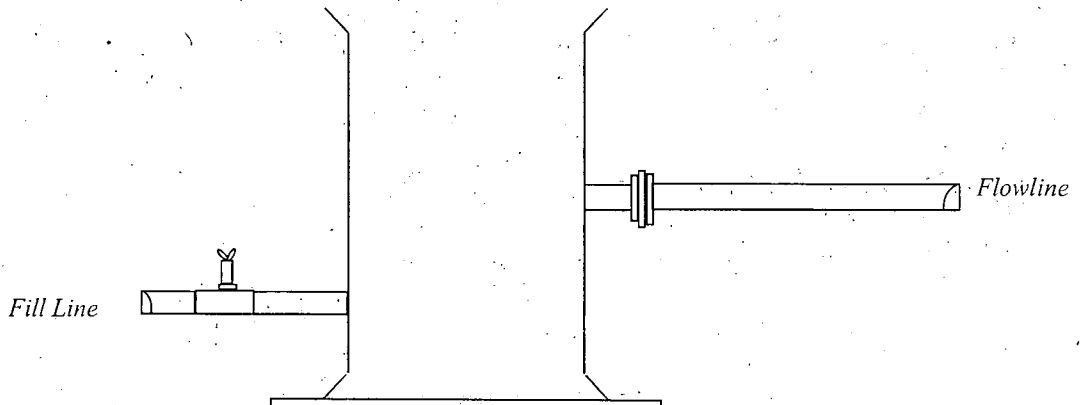

5000# BOP
XTO

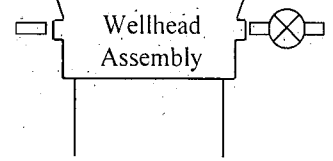

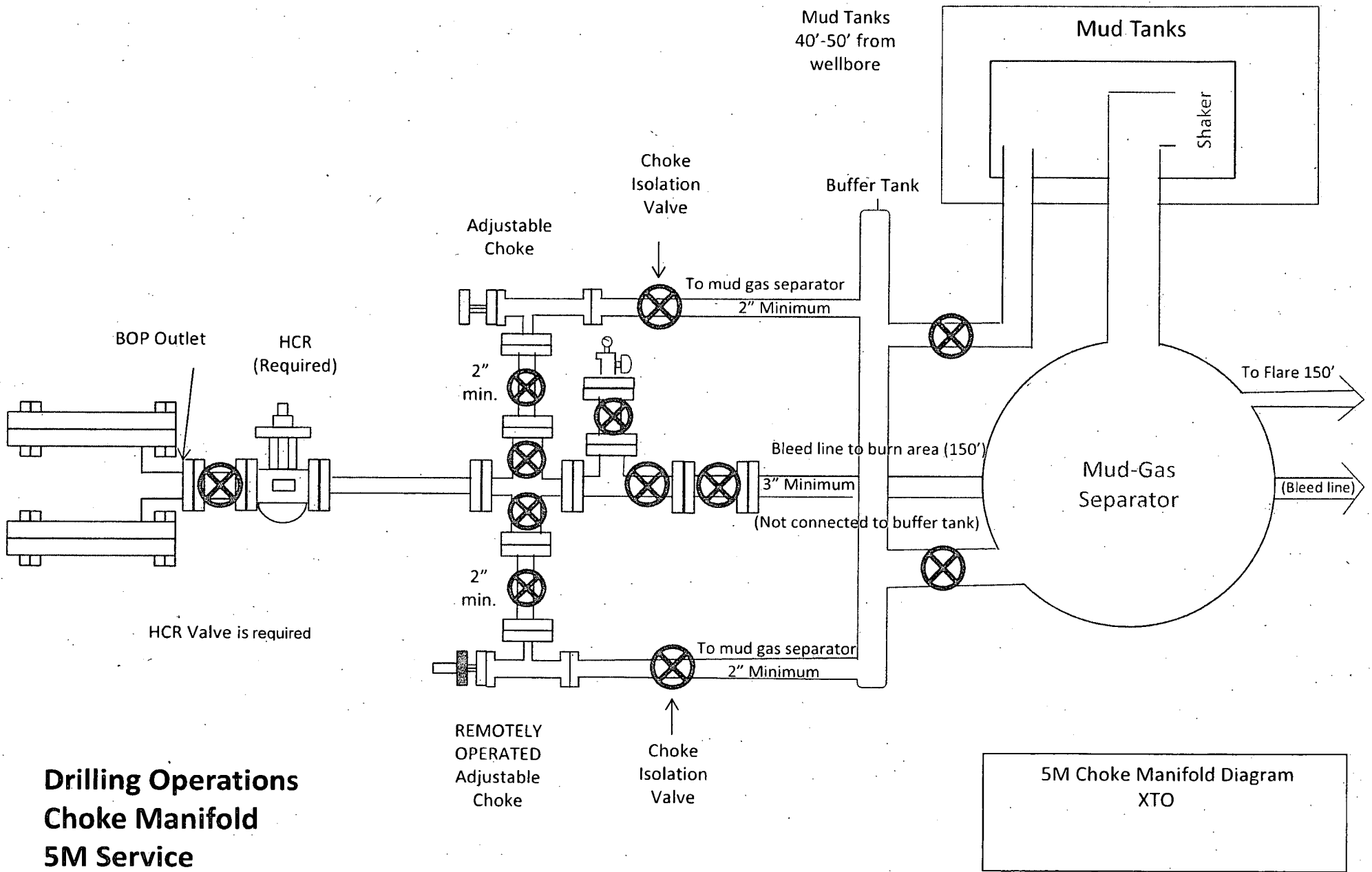

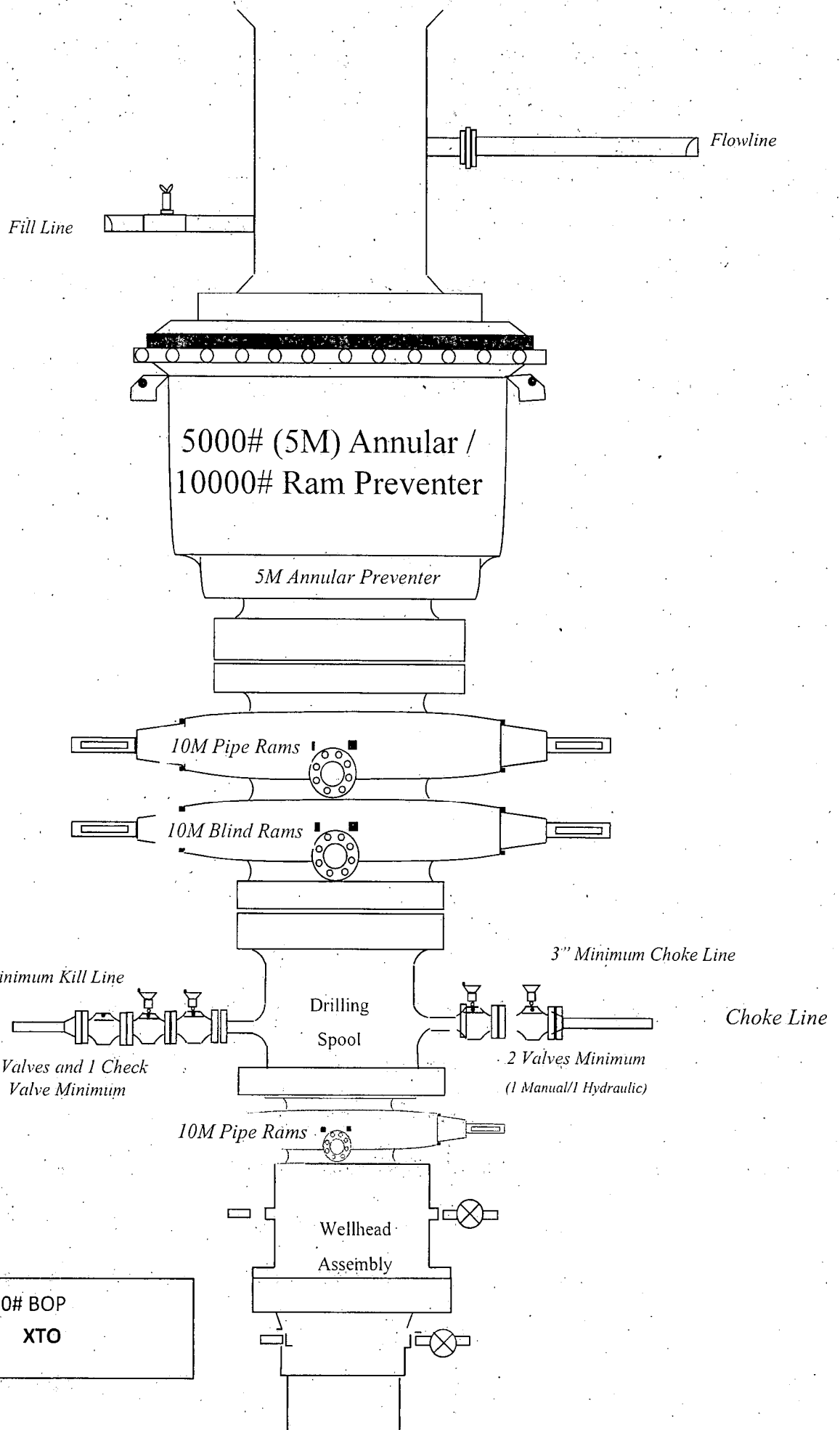

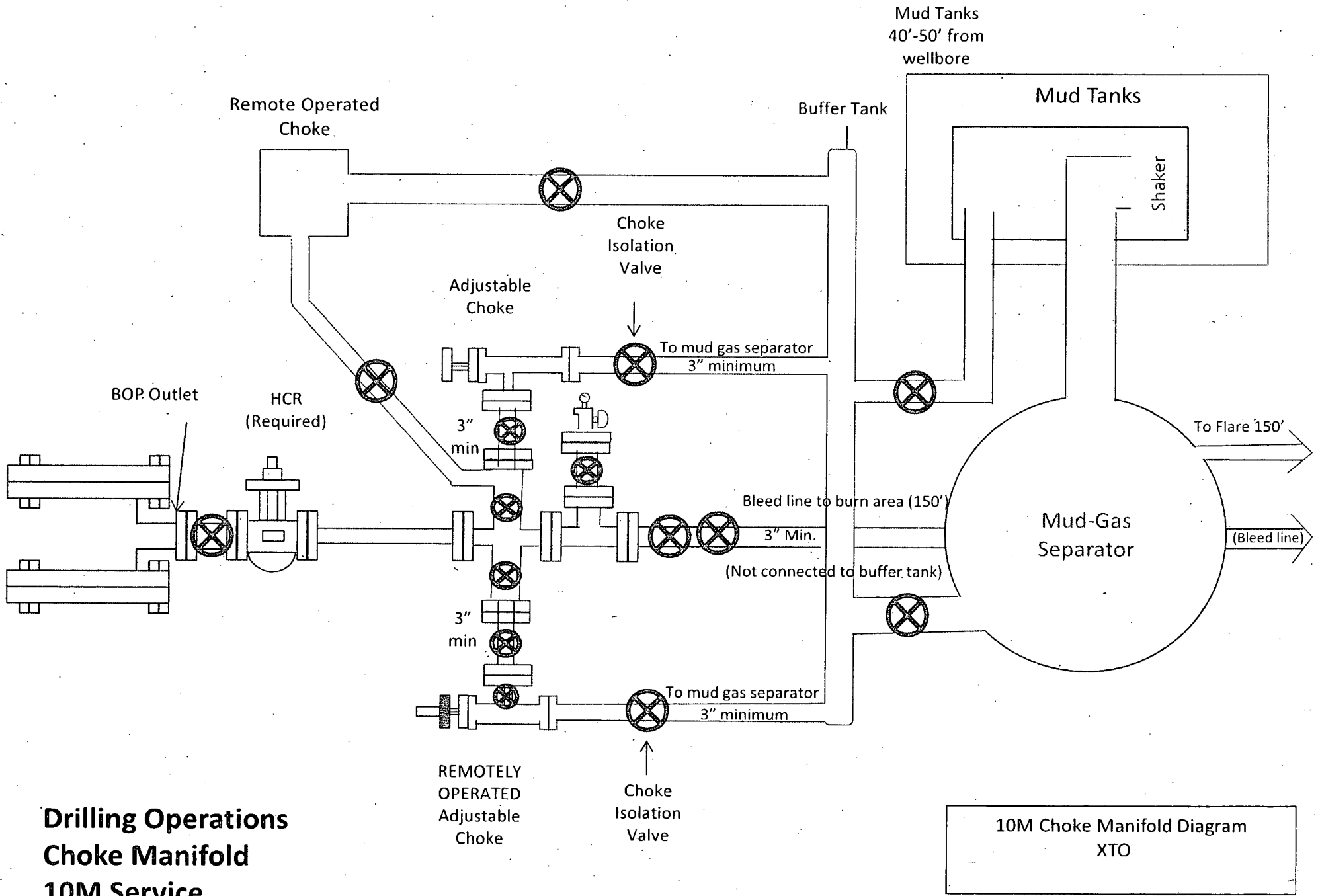

**Drilling Operations
Choke Manifold
10M Service**

10M Choke Manifold Diagram
XTO

10,000 PSI Annular BOP Variance Request

XTO Energy/XTO Permian Op. request a variance to use a 5000 psi annular BOP with a 10,000 psi BOP stack. The component and compatibility tables along with the general well control plans demonstrate how the 5000 psi annular BOP will be protected from pressures that exceed its rated working pressure (RWP). The pressure at which the control of the wellbore is transferred from the annular preventer to another available preventer will not exceed 3500 psi (70% of the RWP of the 5000 psi annular BOPL).

1. Component and Preventer Compatibility Tables

The tables below outline the tubulars and the compatible preventers in use. This table, combined with the drilling fluid, documents that two barriers to flow will be maintained at all times.

8-1/2" Production Hole Section 10M psi Requirement					
Component	OD	Primary Preventer	RWP	Alternate Preventer(s)	RWP
Drillpipe	5.000" or 4.500"	Annular	5M	Upper 3.5"-5.5" VBR Lower 3.5"-5.5" VBR	10M 10M
HWDP	5.000" or 4.500"	Annular	5M	Upper 3.5"-5.5" VBR Lower 3.5"-5.5" VBR	10M 10M
Jars	6.500"	Annular	5M	-	-
DCs and MWD tools	6.500"-8.000"	Annular	5M	-	-
Mud Motor	6.750"-8.000"	Annular	5M	-	-
Production Casing	5-1/2"	Annular	5M	-	-
Open-Hole	-	Blind Rams	10M	-	-

2. Well Control Procedures

Below are the minimal high-level tasks prescribed to assure a proper shut-in while drilling, tripping, running casing, pipe out of the hole (open hole), and moving the BHA through the BOPs. At least one well control drill will be performed weekly per crew to demonstrate compliance with the procedure and well control plan. The well control drill will be recorded in the daily drilling log. The type of drill will be determined by the ongoing operations, but reasonable attempts will be made to vary the type of drill conducted (pit, trip, open hole, choke, etc.). This well control plan will be available for review by rig personnel in the XTO Energy/Permian Operating drilling supervisor's office on location and on the rig floor. All BOP equipment will be tested as per Onshore O&G Order No. 2 with the exception of the 5000 psi annular which will be tested to 70% of its RWP.

General Procedure While Drilling

1. Sound alarm (alert crew)
2. Space out drill string
3. Shut down pumps (stop pumps and rotary)
4. Shut-in well (uppermost applicable BOP, typically annular preventer, first. HCR & choke will already be in the closed position.)
5. Confirm shut-in
6. Notify toolpusher/company representative
7. Read and record the following:
 - a. SIDPP & SICP
 - b. Pit gain
 - c. Time
8. Regroup and identify forward plan

9. If pressure has built or is anticipated during the kill to reach 70% or greater of the RWP of the annular preventer, confirm spacing and close the upper variable bore rams.

General Procedure While Tripping

1. Sound alarm (alert crew)
2. Stab full-opening safety valve & close
3. Space out drill string
4. Shut-in well (uppermost applicable BOP, typically annular preventer, first. HCR & choke will already be in the closed position.)
5. Confirm shut-in
6. Notify toolpusher/company representative
7. Read and record the following:
 - a. SIDPP & SICP
 - b. Pit gain
 - c. Time
8. Regroup and identify forward plan
9. If pressure has built or is anticipated during the kill to reach 70% of the RWP of the annular preventer, confirm spacing and close the upper variable bore rams.

General Procedure While Running Production Casing

1. Sound alarm (alert crew)
2. Stab crossover and full-opening safety valve and close
3. Space out string
4. Shut-in well (uppermost applicable BOP, typically annular preventer, first. HCR & choke will already be in the closed position.)
5. Confirm shut-in
6. Notify toolpusher/company representative
7. Read and record the following:
 - a. SIDPP & SICP
 - b. Pit gain
 - c. Time
8. Regroup and identify forward plan
9. If pressure has built or is anticipated during the kill to reach 70% or greater of the RWP of the annular preventer, confirm spacing and close the upper variable bore rams.

General Procedure With No Pipe In Hole (Open Hole)

1. Sound alarm (alert crew)
2. Shut-in with blind rams (HCR & choke will already be in the closed position)
3. Confirm shut-in
4. Notify toolpusher/company representative
5. Read and record the following:
 - a. SICP
 - b. Pit gain
 - c. Time
6. Regroup and identify forward plan

General Procedures While Pulling BHA Through Stack

1. PRIOR to pulling last joint of drillpipe through stack:
 - a. Perform flow check. If flowing, continue to (b).
 - b. Sound alarm (alert crew)
 - c. Stab full-opening safety valve and close
 - d. Space out drill string with tool joint just beneath the upper variable bore rams
 - e. Shut-in using upper variable bore rams (HCR & choke will already be in the closed position)
 - f. Confirm shut-in
 - g. Notify toolpusher/company representative
 - h. Read and record the following:
 - i. SIDPP & SICP
 - ii. Pit gain
 - iii. Time
 - i. Regroup and identify forward plan
2. With BHA in the stack and compatible ram preventer and pipe combination immediately available:
 - a. Sound alarm (alert crew)
 - b. Stab crossover and full-opening safety valve and close
 - c. Space out drill string with upset just beneath the upper variable bore rams
 - d. Shut-in using upper variable bore rams (HCR & choke will already be in the closed position)
 - e. Confirm shut-in
 - f. Notify toolpusher/company representative
 - g. Read and record the following:
 - i. SIDPP & SICP

- ii. Pit gain
 - iii. Time
 - h. Regroup and identify forward plan
- 3. With BHA in the stack and NO compatible ram preventer and pipe combination immediately available:
 - a. Sound alarm (alert crew)
 - b. If possible, pull string clear of the stack and follow "Open Hole" procedure.
 - c. If impossible to pull string clear of the stack:
 - d. Stab crossover, make up one joint/stand of drillpipe and full-opening safety valve and close
 - e. Space out drill string with tooljoint just beneath the upper variable bore ram
 - f. Shut-in using upper variable bore ram (HCR & choke will already be in the closed position)
 - g. Confirm shut-in
 - h. Notify toolpusher/company representative
 - i. Read and record the following:
 - i. SIDPP & SICP
 - ii. Pit gain
 - iii. Time
 - j. Regroup and identify forward plan



GATES E & S NORTH AMERICA, INC
 DU-TEX
 134 44TH STREET
 CORPUS CHRISTI, TEXAS 78405.

PHONE: 361-887-9807
 FAX: 361-887-0812
 EMAIL: crpe@s@gates.com
 WEB: www.gates.com

GRADE D PRESSURE TEST CERTIFICATE

Customer :	AUSTIN DISTRIBUTING	Test Date:	6/8/2014
Customer Ref. :	PENDING	Hose Serial No.:	D-060811-1
Invoice No. :	201709	Created By:	NORI-1A
Product Description:	FD3.042.0R41/16.5KFLGE/E LE		
End Fitting 1 :	4 1/16 in.5K FLG	End Fitting 2 :	4 1/16 in.5K FLG
Gates Part No. :	4774-6001	Assembly Code :	L33090011S13D-060811-1
Working Pressure :	5,000 PSI	Test Pressure :	7,500 PSI

Gates E & S North America, Inc. certifies that the following hose assembly has been tested to the Gates Oilfield Roughneck Agreement/Specification requirements and passed the 15 minute hydrostatic test per API Spec 7K/Q1, Fifth Edition, June 2010, Test pressure 9.6.7 and per Table 9 to 7,500 psi in accordance with this product number. Hose burst pressure 9.6.7.2 exceeds the minimum of 2.5 times the working pressure per Table 9.

Quality:	QUALITY	Technical Supervisor :	PRODUCTION
Date :	6/8/2014	Date :	6/8/2014
Signature :	<i>[Signature]</i>	Signature :	<i>[Signature]</i>

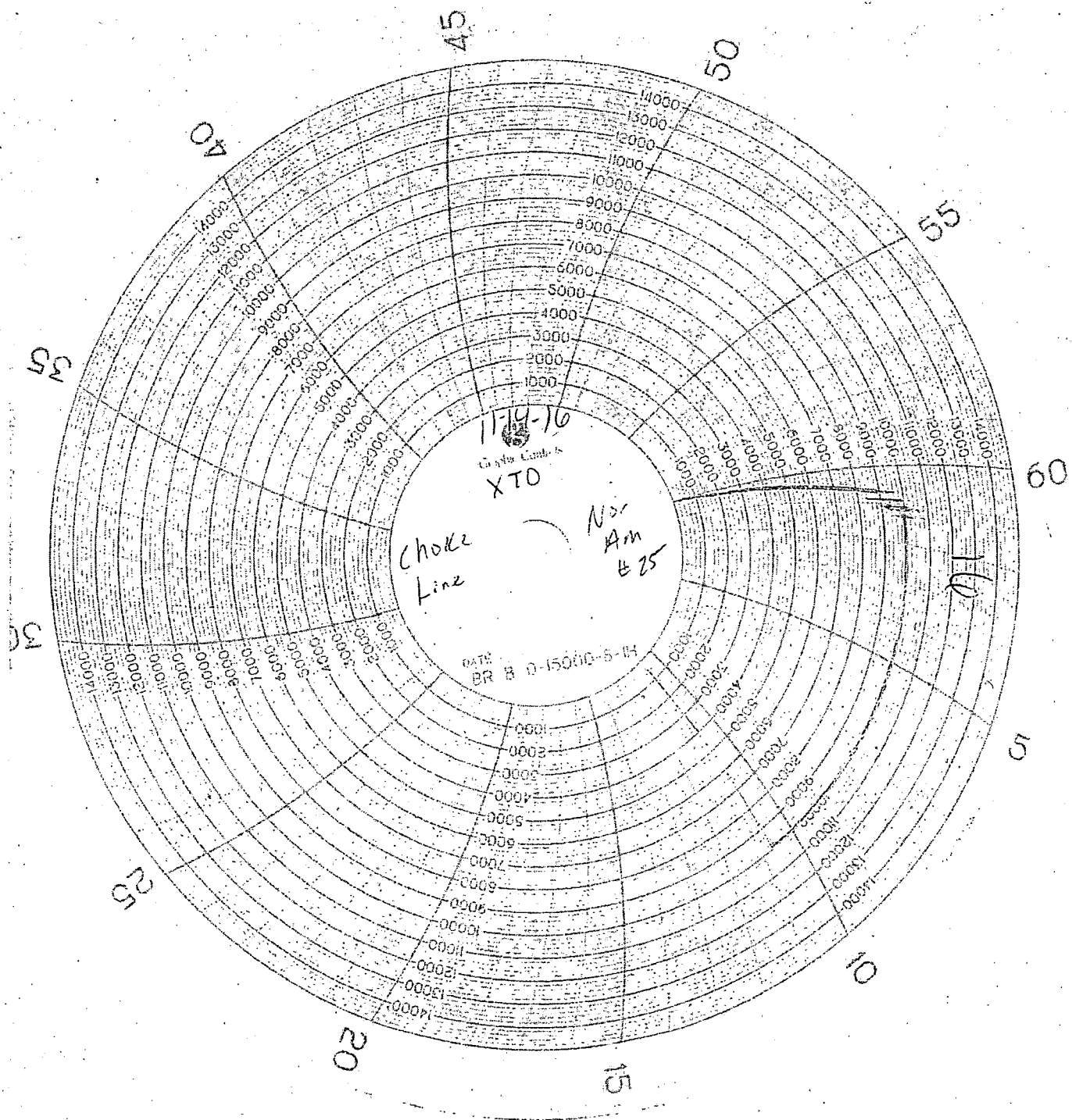

Choke Line

179-16
XTO

No. Am
E 25

PATH
BR B 0-15000-8-14

CA

CA

25

20

15

10

15

60

10

55

50

45

40

NOON

NOSE I.D. 2 3/4" LENGTH 42" END 1 4 1/16" 3/4" END 2 4 1/16" 3/4"

GRADE 24000 WORKING PRESSURE 5000 PSI

TEST PRESSURE 7500 PSI ASSEMBLY DATE 6-8-14

TEST DATE 6-8-14 SERIAL # L3309001513D-060814-13000

NAME D. J. G. CR # 25613

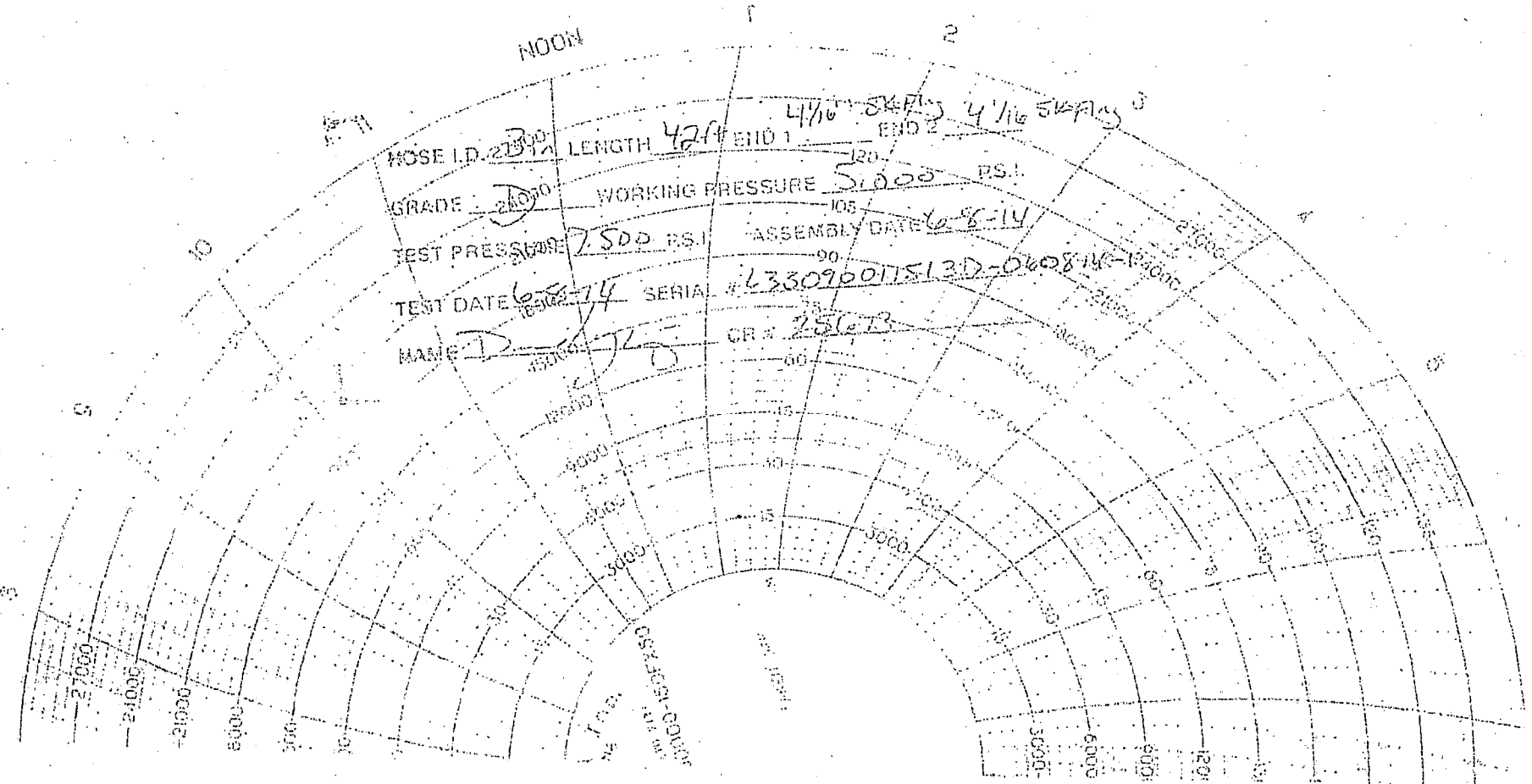

00-21-51-0010
 11-11-11
 11-11-11



XTO Energy

Eddy County, NM

PLU 20 Brushy Draw

PLU 20 Brushy Draw 122H 4/5

Wellbore #1

Plan: plan1

Standard Planning Report

26 July, 2019



a business unit of Turbo Drill Industries, Inc.



Project: Eddy County, NM
 Site: PLU 20 Brushy Draw
 Well: PLU 20 Brushy Draw 122H 4/5
 GL: GL 3158' + 31' KB @ 3189.00usft (Nabors F34)
 SHL Northing: 403645.69
 SHL Easting: 631125.30
 Rig: Nabors F34
 Plan: plan1



SECTION DETAILS

MD	Inc	Azi	TVD	+N-S	+E-W	Dleg	TFace	VSect	Annotation
0.00	0.00	0.00	0.00	0.00	0.00	0.00	0.00	0.00	
10410.12	0.00	0.00	10410.12	0.00	0.00	0.00	0.00	0.00	Start Build 10.00
10860.12	45.00	110.00	10815.26	-57.40	157.69	10.00	110.00	57.97	Start DLS 10.00 TFO 75.41
11618.73	90.00	179.79	11131.00	-611.91	456.03	10.00	75.41	613.57	LP - Start 10138.86 hold at 11618.73 MD
21757.58	90.00	179.79	11131.00	-10750.69	493.20	0.00	0.00	10752.43	TD at 21757.59 MD

FORMATION TOP DETAILS

TVDPath	MDPath	Formation
609.00	609.00	RSLR
686.00	686.00	T5sh
2098.00	2098.00	CS 1L
3397.00	3397.00	San B
3587.00	3587.00	DLWR
3612.00	3612.00	BLCN
4515.00	4515.00	CVCN
6102.00	6102.00	BYCL
7173.00	7173.00	8BYCN
7433.00	7433.00	BSPG LM
7559.00	7559.00	BSPG Avn SS
7574.00	7574.00	BSPG U Avn SH
7970.00	7970.00	BSPG L Avn SH
8354.00	8354.00	BSPG1 LM
8378.00	8378.00	BSPG1
8807.00	8807.00	BSPG2 LM
9200.00	9200.00	BSPG2
9539.00	9539.00	BSPG3 LM
9849.00	9849.00	BSPG Flyk
9879.00	9879.00	BSPG3 SH
10092.00	10092.00	BSPG3 LM Lwr
10133.00	10133.00	BSPG3 SH Lwr
10259.00	10259.00	BSPG3
10614.00	10614.00	BSPG3 RH
10655.00	10655.00	WFMP
10795.00	10795.00	WFMP X
10872.00	10872.00	WFMP Y
10848.00	10853.99	WFMP X
10899.00	11150.34	WFMP A Lower

DESIGN TARGET DETAILS

Name	TVD	+N-S	+E-W	Northing	Easting
PLU 20 Brushy Draw 122H BHL	11131.00	-10750.69	493.20	392895.00	631618.50
PLU 20 Brushy Draw 122H FTP	11131.00	-654.69	453.40	402991.00	631578.70
PLU 20 Brushy Draw 122H LTP	11131.00	-10620.69	493.00	393025.00	631618.30

T G M
 Azimuths to Grid North
 True North: -0.23°
 Magnetic North: 6.58°
 Magnetic Field
 Strength: 47837.05nT
 Dip Angle: 59.75°
 Date: 04/29/2019
 Model: HDGM

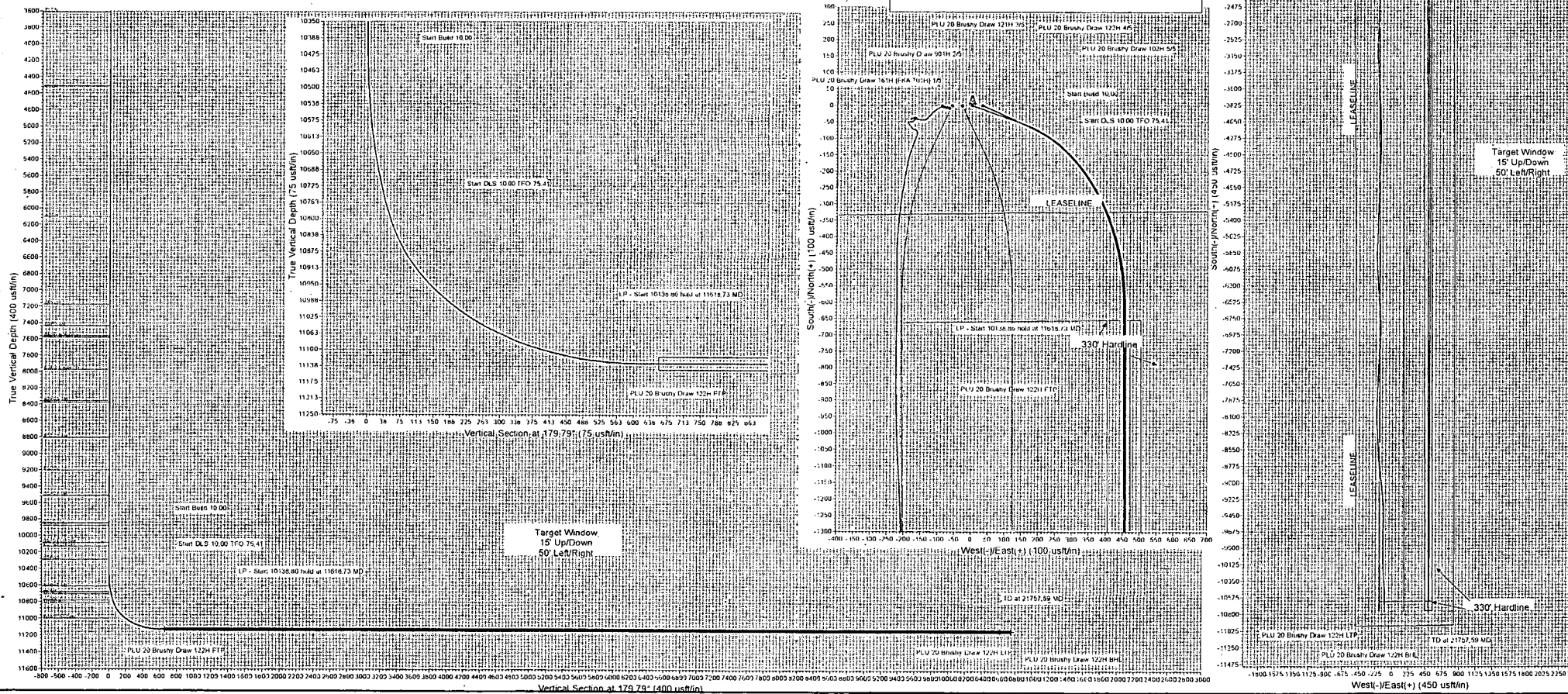



Planning Report



Database:	EDM 5000.14 Single User Db	Local Co-ordinate Reference:	Well: PLU 20 Brushy Draw 122H 4/5
Company:	XTO Energy	TVD Reference:	GL 3158' + 31' KB @ 3189.00usft (Nabors F34)
Project:	Eddy County, NM	MD Reference:	GL 3158' + 31' KB @ 3189.00usft (Nabors F34)
Site:	PLU 20 Brushy Draw	North Reference:	Grid:
Well:	PLU 20 Brushy Draw 122H 4/5	Survey Calculation Method:	Minimum Curvature
Wellbore:	Wellbore #1		
Design:	plan1		

Project:	Eddy County, NM		
Map System:	US State Plane 1927 (Exact solution)	System Datum:	Mean Sea Level
Geo Datum:	NAD 1927 (NADCON CONUS)		
Map Zone:	New Mexico East 3001		

Site:	PLU 20 Brushy Draw		
Site Position:	Map	Northing:	403,644.60 usft
From:		Easting:	631,035.20 usft
Position Uncertainty:	0.00 usft	Slot Radius:	13-3/16 "
		Latitude:	32° 6' 32.501 N
		Longitude:	103° 54' 36.475 W
		Grid Convergence:	0.22 °

Well:	PLU 20 Brushy Draw 122H 4/5		
Well Position	+N-S	1.09 usft	Northing:
	+E-W	90.10 usft	Easting:
Position Uncertainty	0.00 usft	Wellhead Elevation:	403,645.69 usft
		Ground Level:	631,125.30 usft
			Latitude:
			Longitude:
			31,158.00 usft

Wellbore:	Wellbore #1		
Magnetics:	Model Name	Sample Date	Declination
	HDGM	04/29/19	(°)
			Dip Angle
			(°)
			Field Strength
			(nT)
			6.80
			59.75
			47,837.00000000

Design:	plan1		
Audit Notes:			
Version:	Phase:	PLAN	Tie On Depth:
			0.00
Vertical Section:	Depth From (TVD)	+N-S	+E-W
	(usft)	(usft)	(usft)
	0.00	0.00	0.00
			Direction
			(°)
			179.79

Plan Survey Tool Program	Date:	07/26/19	
Depth From (usft)	Depth To (usft)	Survey (Wellbore)	Tool Name
1	0.00	21,757.59 plan1 (Wellbore #1)	A008Mb_MWD+IFR1+MS
			OWSG MWD + IFR1 + Multi-St

Plan Sections										
Measured Depth (usft)	Inclination (°)	Azimuth (°)	Vertical Depth (usft)	+N-S (usft)	+E-W (usft)	Dogleg Rate (°/100usft)	Build Rate (°/100usft)	Turn Rate (°/100usft)	TFO (°)	Target
0.00	0.00	0.00	0.00	0.00	0.00	0.00	0.00	0.00	0.00	
10,410.12	0.00	0.00	10,410.12	0.00	0.00	0.00	0.00	0.00	0.00	
10,860.12	45.00	110.00	10,815.26	-57.40	157.69	10.00	10.00	0.00	110.00	
11,618.73	90.00	179.79	11,131.00	-611.91	456.03	10.00	5.93	9.20	75.41	
21,757.58	90.00	179.79	11,131.00	-10,750.69	493.20	0.00	0.00	0.00	0.00	PLU 20 Brushy Draw



Planning Report



Database:	EDM 5000.14 Single User Db	Local Co-ordinate Reference:	Well PLU 20 Brushy Draw 122H 4/5
Company:	XTO Energy	TVD Reference:	GL 3158' + 31' KB @ 3189.00usft (Nabors F34)
Project:	Eddy County, NM	MD Reference:	GL 3158' + 31' KB @ 3189.00usft (Nabors F34)
Site:	PLU 20 Brushy Draw	North Reference:	Grid
Well:	PLU 20 Brushy Draw 122H 4/5	Survey Calculation Method:	Minimum Curvature
Wellbore:	Wellbore #1		
Design:	plan1		

Planned Survey										
Measured Depth (usft)	Inclination (°)	Azimuth (°)	Vertical Depth (usft)	+N/S (usft)	+E/W (usft)	Vertical Section (usft)	Dogleg Rate (°/100usft)	Build Rate (°/100usft)	Turn Rate (°/100usft)	
0.00	0.00	0.00	0.00	0.00	0.00	0.00	0.00	0.00	0.00	0.00
100.00	0.00	0.00	100.00	0.00	0.00	0.00	0.00	0.00	0.00	0.00
200.00	0.00	0.00	200.00	0.00	0.00	0.00	0.00	0.00	0.00	0.00
300.00	0.00	0.00	300.00	0.00	0.00	0.00	0.00	0.00	0.00	0.00
400.00	0.00	0.00	400.00	0.00	0.00	0.00	0.00	0.00	0.00	0.00
500.00	0.00	0.00	500.00	0.00	0.00	0.00	0.00	0.00	0.00	0.00
600.00	0.00	0.00	600.00	0.00	0.00	0.00	0.00	0.00	0.00	0.00
609.00	0.00	0.00	609.00	0.00	0.00	0.00	0.00	0.00	0.00	0.00
RSLR										
696.00	0.00	0.00	696.00	0.00	0.00	0.00	0.00	0.00	0.00	0.00
T/Salt										
700.00	0.00	0.00	700.00	0.00	0.00	0.00	0.00	0.00	0.00	0.00
800.00	0.00	0.00	800.00	0.00	0.00	0.00	0.00	0.00	0.00	0.00
900.00	0.00	0.00	900.00	0.00	0.00	0.00	0.00	0.00	0.00	0.00
1,000.00	0.00	0.00	1,000.00	0.00	0.00	0.00	0.00	0.00	0.00	0.00
1,100.00	0.00	0.00	1,100.00	0.00	0.00	0.00	0.00	0.00	0.00	0.00
1,200.00	0.00	0.00	1,200.00	0.00	0.00	0.00	0.00	0.00	0.00	0.00
1,300.00	0.00	0.00	1,300.00	0.00	0.00	0.00	0.00	0.00	0.00	0.00
1,400.00	0.00	0.00	1,400.00	0.00	0.00	0.00	0.00	0.00	0.00	0.00
1,500.00	0.00	0.00	1,500.00	0.00	0.00	0.00	0.00	0.00	0.00	0.00
1,600.00	0.00	0.00	1,600.00	0.00	0.00	0.00	0.00	0.00	0.00	0.00
1,700.00	0.00	0.00	1,700.00	0.00	0.00	0.00	0.00	0.00	0.00	0.00
1,800.00	0.00	0.00	1,800.00	0.00	0.00	0.00	0.00	0.00	0.00	0.00
1,900.00	0.00	0.00	1,900.00	0.00	0.00	0.00	0.00	0.00	0.00	0.00
2,000.00	0.00	0.00	2,000.00	0.00	0.00	0.00	0.00	0.00	0.00	0.00
2,098.00	0.00	0.00	2,098.00	0.00	0.00	0.00	0.00	0.00	0.00	0.00
CSTL										
2,100.00	0.00	0.00	2,100.00	0.00	0.00	0.00	0.00	0.00	0.00	0.00
2,200.00	0.00	0.00	2,200.00	0.00	0.00	0.00	0.00	0.00	0.00	0.00
2,300.00	0.00	0.00	2,300.00	0.00	0.00	0.00	0.00	0.00	0.00	0.00
2,400.00	0.00	0.00	2,400.00	0.00	0.00	0.00	0.00	0.00	0.00	0.00
2,500.00	0.00	0.00	2,500.00	0.00	0.00	0.00	0.00	0.00	0.00	0.00
2,600.00	0.00	0.00	2,600.00	0.00	0.00	0.00	0.00	0.00	0.00	0.00
2,700.00	0.00	0.00	2,700.00	0.00	0.00	0.00	0.00	0.00	0.00	0.00
2,800.00	0.00	0.00	2,800.00	0.00	0.00	0.00	0.00	0.00	0.00	0.00
2,900.00	0.00	0.00	2,900.00	0.00	0.00	0.00	0.00	0.00	0.00	0.00
3,000.00	0.00	0.00	3,000.00	0.00	0.00	0.00	0.00	0.00	0.00	0.00
3,100.00	0.00	0.00	3,100.00	0.00	0.00	0.00	0.00	0.00	0.00	0.00
3,200.00	0.00	0.00	3,200.00	0.00	0.00	0.00	0.00	0.00	0.00	0.00
3,300.00	0.00	0.00	3,300.00	0.00	0.00	0.00	0.00	0.00	0.00	0.00
3,397.00	0.00	0.00	3,397.00	0.00	0.00	0.00	0.00	0.00	0.00	0.00
Salt B										
3,400.00	0.00	0.00	3,400.00	0.00	0.00	0.00	0.00	0.00	0.00	0.00
3,500.00	0.00	0.00	3,500.00	0.00	0.00	0.00	0.00	0.00	0.00	0.00
3,587.00	0.00	0.00	3,587.00	0.00	0.00	0.00	0.00	0.00	0.00	0.00
DLWR										
3,600.00	0.00	0.00	3,600.00	0.00	0.00	0.00	0.00	0.00	0.00	0.00
3,612.00	0.00	0.00	3,612.00	0.00	0.00	0.00	0.00	0.00	0.00	0.00
BLCN										
3,700.00	0.00	0.00	3,700.00	0.00	0.00	0.00	0.00	0.00	0.00	0.00
3,800.00	0.00	0.00	3,800.00	0.00	0.00	0.00	0.00	0.00	0.00	0.00



Database:	EDM 5000.14 Single User Db.	Local Co-ordinate Reference:	Well PLU 20 Brushy Draw 122H 4/5
Company:	XTO Energy	TVD Reference:	GL 3158' + 31' KB @ 3189.00usft (Nabors F34)
Project:	Eddy County, NM	MD Reference:	GL 3158' + 31' KB @ 3189.00usft (Nabors F34)
Site:	PLU 20 Brushy Draw	North Reference:	Grid
Well:	PLU 20 Brushy Draw 122H 4/5	Survey Calculation Method:	Minimum Curvature
Wellbore:	Wellbore #1		
Design:	plan1		

Planned Survey										
Measured Depth (usft)	Inclination (°)	Azimuth (°)	Vertical Depth (usft)	+N/-S (usft)	+E/-W (usft)	Vertical Section (usft)	Dogleg Rate (°/100usft)	Build Rate (°/100usft)	Turn Rate (°/100usft)	
3,900.00	0.00	0.00	3,900.00	0.00	0.00	0.00	0.00	0.00	0.00	0.00
4,000.00	0.00	0.00	4,000.00	0.00	0.00	0.00	0.00	0.00	0.00	0.00
4,100.00	0.00	0.00	4,100.00	0.00	0.00	0.00	0.00	0.00	0.00	0.00
4,200.00	0.00	0.00	4,200.00	0.00	0.00	0.00	0.00	0.00	0.00	0.00
4,300.00	0.00	0.00	4,300.00	0.00	0.00	0.00	0.00	0.00	0.00	0.00
4,400.00	0.00	0.00	4,400.00	0.00	0.00	0.00	0.00	0.00	0.00	0.00
4,500.00	0.00	0.00	4,500.00	0.00	0.00	0.00	0.00	0.00	0.00	0.00
4,515.00	0.00	0.00	4,515.00	0.00	0.00	0.00	0.00	0.00	0.00	0.00
CYCN										
4,600.00	0.00	0.00	4,600.00	0.00	0.00	0.00	0.00	0.00	0.00	0.00
4,700.00	0.00	0.00	4,700.00	0.00	0.00	0.00	0.00	0.00	0.00	0.00
4,800.00	0.00	0.00	4,800.00	0.00	0.00	0.00	0.00	0.00	0.00	0.00
4,900.00	0.00	0.00	4,900.00	0.00	0.00	0.00	0.00	0.00	0.00	0.00
5,000.00	0.00	0.00	5,000.00	0.00	0.00	0.00	0.00	0.00	0.00	0.00
5,100.00	0.00	0.00	5,100.00	0.00	0.00	0.00	0.00	0.00	0.00	0.00
5,200.00	0.00	0.00	5,200.00	0.00	0.00	0.00	0.00	0.00	0.00	0.00
5,300.00	0.00	0.00	5,300.00	0.00	0.00	0.00	0.00	0.00	0.00	0.00
5,400.00	0.00	0.00	5,400.00	0.00	0.00	0.00	0.00	0.00	0.00	0.00
5,500.00	0.00	0.00	5,500.00	0.00	0.00	0.00	0.00	0.00	0.00	0.00
5,600.00	0.00	0.00	5,600.00	0.00	0.00	0.00	0.00	0.00	0.00	0.00
5,700.00	0.00	0.00	5,700.00	0.00	0.00	0.00	0.00	0.00	0.00	0.00
5,800.00	0.00	0.00	5,800.00	0.00	0.00	0.00	0.00	0.00	0.00	0.00
5,900.00	0.00	0.00	5,900.00	0.00	0.00	0.00	0.00	0.00	0.00	0.00
6,000.00	0.00	0.00	6,000.00	0.00	0.00	0.00	0.00	0.00	0.00	0.00
6,100.00	0.00	0.00	6,100.00	0.00	0.00	0.00	0.00	0.00	0.00	0.00
6,102.00	0.00	0.00	6,102.00	0.00	0.00	0.00	0.00	0.00	0.00	0.00
BYCN										
6,200.00	0.00	0.00	6,200.00	0.00	0.00	0.00	0.00	0.00	0.00	0.00
6,300.00	0.00	0.00	6,300.00	0.00	0.00	0.00	0.00	0.00	0.00	0.00
6,400.00	0.00	0.00	6,400.00	0.00	0.00	0.00	0.00	0.00	0.00	0.00
6,500.00	0.00	0.00	6,500.00	0.00	0.00	0.00	0.00	0.00	0.00	0.00
6,600.00	0.00	0.00	6,600.00	0.00	0.00	0.00	0.00	0.00	0.00	0.00
6,700.00	0.00	0.00	6,700.00	0.00	0.00	0.00	0.00	0.00	0.00	0.00
6,800.00	0.00	0.00	6,800.00	0.00	0.00	0.00	0.00	0.00	0.00	0.00
6,900.00	0.00	0.00	6,900.00	0.00	0.00	0.00	0.00	0.00	0.00	0.00
7,000.00	0.00	0.00	7,000.00	0.00	0.00	0.00	0.00	0.00	0.00	0.00
7,100.00	0.00	0.00	7,100.00	0.00	0.00	0.00	0.00	0.00	0.00	0.00
7,173.00	0.00	0.00	7,173.00	0.00	0.00	0.00	0.00	0.00	0.00	0.00
BBYCN										
7,200.00	0.00	0.00	7,200.00	0.00	0.00	0.00	0.00	0.00	0.00	0.00
7,300.00	0.00	0.00	7,300.00	0.00	0.00	0.00	0.00	0.00	0.00	0.00
7,400.00	0.00	0.00	7,400.00	0.00	0.00	0.00	0.00	0.00	0.00	0.00
7,433.00	0.00	0.00	7,433.00	0.00	0.00	0.00	0.00	0.00	0.00	0.00
BSPG LM										
7,500.00	0.00	0.00	7,500.00	0.00	0.00	0.00	0.00	0.00	0.00	0.00
7,559.00	0.00	0.00	7,559.00	0.00	0.00	0.00	0.00	0.00	0.00	0.00
BSPG Avin SS										
7,574.00	0.00	0.00	7,574.00	0.00	0.00	0.00	0.00	0.00	0.00	0.00
BSPG U Avin SH										
7,600.00	0.00	0.00	7,600.00	0.00	0.00	0.00	0.00	0.00	0.00	0.00
7,700.00	0.00	0.00	7,700.00	0.00	0.00	0.00	0.00	0.00	0.00	0.00



Database:	EDM 5000.14 Single User Db	Local Co-ordinate Reference:	Well PLU 20 Brushy Draw 122H 4/5
Company:	XTO Energy	TVD Reference:	GL 3158' + 31' KB @ 3189.00usft (Nabors F34)
Project:	Eddy County, NM	MD Reference:	GL 3158' + 31' KB @ 3189.00usft (Nabors F34)
Site:	PLU 20 Brushy Draw	North Reference:	Grid:
Well:	PLU 20 Brushy Draw 122H 4/5	Survey Calculation Method:	Minimum Curvature
Wellbore:	Wellbore #1		
Design:	plan1		

Planned Survey										
Measured Depth (usft)	Inclination (°)	Azimuth (°)	Vertical Depth (usft)	+N/S (usft)	+E/W (usft)	Vertical Section (usft)	Dogleg Rate (°/100usft)	Build Rate (°/100usft)	Turn Rate (°/100usft)	
7,800.00	0.00	0.00	7,800.00	0.00	0.00	0.00	0.00	0.00	0.00	0.00
7,900.00	0.00	0.00	7,900.00	0.00	0.00	0.00	0.00	0.00	0.00	0.00
7,970.00	0.00	0.00	7,970.00	0.00	0.00	0.00	0.00	0.00	0.00	0.00
BSPG L Avln SH										
8,000.00	0.00	0.00	8,000.00	0.00	0.00	0.00	0.00	0.00	0.00	0.00
8,100.00	0.00	0.00	8,100.00	0.00	0.00	0.00	0.00	0.00	0.00	0.00
8,200.00	0.00	0.00	8,200.00	0.00	0.00	0.00	0.00	0.00	0.00	0.00
8,300.00	0.00	0.00	8,300.00	0.00	0.00	0.00	0.00	0.00	0.00	0.00
8,354.00	0.00	0.00	8,354.00	0.00	0.00	0.00	0.00	0.00	0.00	0.00
BSPG1 LM										
8,378.00	0.00	0.00	8,378.00	0.00	0.00	0.00	0.00	0.00	0.00	0.00
BSPG1										
8,400.00	0.00	0.00	8,400.00	0.00	0.00	0.00	0.00	0.00	0.00	0.00
8,500.00	0.00	0.00	8,500.00	0.00	0.00	0.00	0.00	0.00	0.00	0.00
8,600.00	0.00	0.00	8,600.00	0.00	0.00	0.00	0.00	0.00	0.00	0.00
8,700.00	0.00	0.00	8,700.00	0.00	0.00	0.00	0.00	0.00	0.00	0.00
8,800.00	0.00	0.00	8,800.00	0.00	0.00	0.00	0.00	0.00	0.00	0.00
8,807.00	0.00	0.00	8,807.00	0.00	0.00	0.00	0.00	0.00	0.00	0.00
BSPG2 LM										
8,900.00	0.00	0.00	8,900.00	0.00	0.00	0.00	0.00	0.00	0.00	0.00
9,000.00	0.00	0.00	9,000.00	0.00	0.00	0.00	0.00	0.00	0.00	0.00
9,100.00	0.00	0.00	9,100.00	0.00	0.00	0.00	0.00	0.00	0.00	0.00
9,200.00	0.00	0.00	9,200.00	0.00	0.00	0.00	0.00	0.00	0.00	0.00
BSPG2										
9,300.00	0.00	0.00	9,300.00	0.00	0.00	0.00	0.00	0.00	0.00	0.00
9,400.00	0.00	0.00	9,400.00	0.00	0.00	0.00	0.00	0.00	0.00	0.00
9,500.00	0.00	0.00	9,500.00	0.00	0.00	0.00	0.00	0.00	0.00	0.00
9,509.00	0.00	0.00	9,509.00	0.00	0.00	0.00	0.00	0.00	0.00	0.00
BSPG3 LM										
9,600.00	0.00	0.00	9,600.00	0.00	0.00	0.00	0.00	0.00	0.00	0.00
9,700.00	0.00	0.00	9,700.00	0.00	0.00	0.00	0.00	0.00	0.00	0.00
9,800.00	0.00	0.00	9,800.00	0.00	0.00	0.00	0.00	0.00	0.00	0.00
9,849.00	0.00	0.00	9,849.00	0.00	0.00	0.00	0.00	0.00	0.00	0.00
BSPG Hrky										
9,879.00	0.00	0.00	9,879.00	0.00	0.00	0.00	0.00	0.00	0.00	0.00
BSPG3 SH										
9,900.00	0.00	0.00	9,900.00	0.00	0.00	0.00	0.00	0.00	0.00	0.00
10,000.00	0.00	0.00	10,000.00	0.00	0.00	0.00	0.00	0.00	0.00	0.00
10,092.00	0.00	0.00	10,092.00	0.00	0.00	0.00	0.00	0.00	0.00	0.00
BSPG3 LM Lwr										
10,100.00	0.00	0.00	10,100.00	0.00	0.00	0.00	0.00	0.00	0.00	0.00
10,133.00	0.00	0.00	10,133.00	0.00	0.00	0.00	0.00	0.00	0.00	0.00
BSPG3 SH Lwr										
10,200.00	0.00	0.00	10,200.00	0.00	0.00	0.00	0.00	0.00	0.00	0.00
10,289.00	0.00	0.00	10,289.00	0.00	0.00	0.00	0.00	0.00	0.00	0.00
BSPG3										
10,300.00	0.00	0.00	10,300.00	0.00	0.00	0.00	0.00	0.00	0.00	0.00
10,400.00	0.00	0.00	10,400.00	0.00	0.00	0.00	0.00	0.00	0.00	0.00
10,410.12	0.00	0.00	10,410.12	0.00	0.00	0.00	0.00	0.00	0.00	0.00
Start Build 10.00										
10,500.00	8.99	110.00	10,499.63	-2.41	6.61	2.43	10.00	10.00	0.00	0.00



Planning Report



Database:	EDM 5000.14 Single User Db	Local Co-ordinate Reference:	Well PLU 20 Brushy Draw 122H 4/5
Company:	XTO Energy	TVD Reference:	GL 3158' + 31' KB @ 3189.00usft (Nabors F34)
Project:	Eddy County, NM	MD Reference:	GL 3158' + 31' KB @ 3189.00usft (Nabors F34)
Site:	PLU 20 Brushy Draw	North Reference:	Grid:
Well:	PLU 20 Brushy Draw 122H 4/5	Survey Calculation Method:	Minimum Curvature
Wellbore:	Wellbore #1		
Design:	plan1		

Planned Survey									
Measured Depth (usft)	Inclination (°)	Azimuth (°)	Vertical Depth (usft)	+N/-S (usft)	+E/-W (usft)	Vertical Section (usft)	Dogleg Rate (°/100usft)	Build Rate (°/100usft)	Turn Rate (°/100usft)
10,600.00	18.99	110.00	10,596.54	-10.66	29.30	10.77	10.00	10.00	0.00
10,618.57	20.84	110.00	10,614.00	-12.83	35.24	12.96	10.00	10.00	0.00
BSPG3 RH									
10,696.81	28.67	110.00	10,685.00	-24.02	66.01	24.27	10.00	10.00	0.00
WFMP									
10,700.00	28.99	110.00	10,687.79	-24.55	67.45	24.80	10.00	10.00	0.00
10,723.37	31.33	110.00	10,708.00	-28.57	78.48	28.85	10.00	10.00	0.00
WFMP X									
10,800.00	38.99	110.00	10,770.60	-43.65	119.91	44.08	10.00	10.00	0.00
10,821.43	41.13	110.00	10,787.00	-48.36	132.87	48.85	10.00	10.00	0.00
WFMP Y									
10,860.12	45.00	110.00	10,815.26	-57.40	157.69	57.97	10.00	10.00	0.00
Start DLS 10.00 TFO 75.41									
10,864.00	45.10	110.53	10,818.00	-58.35	160.27	58.93	10.00	2.55	13.66
WFMP A									
10,900.00	46.13	115.36	10,843.19	-68.38	183.95	69.05	10.00	2.87	13.41
11,000.00	49.98	127.79	10,910.17	-107.38	246.94	108.28	10.00	3.85	12.43
11,100.00	55.00	138.71	10,971.16	-161.75	304.37	162.86	10.00	5.02	10.92
11,150.34	57.87	143.67	10,999.00	-194.43	330.62	195.64	10.00	5.70	9.87
WFMP A Lower									
11,200.00	60.87	148.26	11,024.31	-229.84	354.50	231.14	10.00	6.06	9.25
11,300.00	67.35	156.74	11,068.01	-309.58	395.81	311.03	10.00	6.48	8.48
11,400.00	74.24	164.43	11,100.93	-398.56	427.02	400.12	10.00	6.88	7.69
11,500.00	81.37	171.60	11,122.06	-494.06	447.21	495.69	10.00	7.13	7.17
11,600.00	88.63	178.51	11,130.78	-593.18	455.75	594.85	10.00	7.26	6.90
11,618.73	90.00	179.79	11,131.00	-611.91	456.03	613.57	10.00	7.29	6.84
LP - Start 10138.86 hold at 11618.73 MD									
11,661.50	90.00	179.79	11,131.00	-654.68	456.19	656.35	0.00	0.00	0.00
PLU 20 Brushy Draw 122H FTP									
11,700.00	90.00	179.79	11,131.00	-693.18	456.33	694.85	0.00	0.00	0.00
11,800.00	90.00	179.79	11,131.00	-793.18	456.69	794.85	0.00	0.00	0.00
11,900.00	90.00	179.79	11,131.00	-893.18	457.06	894.85	0.00	0.00	0.00
12,000.00	90.00	179.79	11,131.00	-993.18	457.43	994.85	0.00	0.00	0.00
12,100.00	90.00	179.79	11,131.00	-1,093.18	457.79	1,094.85	0.00	0.00	0.00
12,200.00	90.00	179.79	11,131.00	-1,193.17	458.16	1,194.85	0.00	0.00	0.00
12,300.00	90.00	179.79	11,131.00	-1,293.17	458.53	1,294.85	0.00	0.00	0.00
12,400.00	90.00	179.79	11,131.00	-1,393.17	458.89	1,394.85	0.00	0.00	0.00
12,500.00	90.00	179.79	11,131.00	-1,493.17	459.26	1,494.85	0.00	0.00	0.00
12,600.00	90.00	179.79	11,131.00	-1,593.17	459.63	1,594.85	0.00	0.00	0.00
12,700.00	90.00	179.79	11,131.00	-1,693.17	459.99	1,694.85	0.00	0.00	0.00
12,800.00	90.00	179.79	11,131.00	-1,793.17	460.36	1,794.85	0.00	0.00	0.00
12,900.00	90.00	179.79	11,131.00	-1,893.17	460.73	1,894.85	0.00	0.00	0.00
13,000.00	90.00	179.79	11,131.00	-1,993.17	461.09	1,994.85	0.00	0.00	0.00
13,100.00	90.00	179.79	11,131.00	-2,093.17	461.46	2,094.85	0.00	0.00	0.00
13,200.00	90.00	179.79	11,131.00	-2,193.17	461.83	2,194.85	0.00	0.00	0.00
13,300.00	90.00	179.79	11,131.00	-2,293.17	462.19	2,294.85	0.00	0.00	0.00
13,400.00	90.00	179.79	11,131.00	-2,393.17	462.56	2,394.85	0.00	0.00	0.00
13,500.00	90.00	179.79	11,131.00	-2,493.17	462.93	2,494.85	0.00	0.00	0.00
13,600.00	90.00	179.79	11,131.00	-2,593.17	463.29	2,594.85	0.00	0.00	0.00
13,700.00	90.00	179.79	11,131.00	-2,693.16	463.66	2,694.85	0.00	0.00	0.00
13,800.00	90.00	179.79	11,131.00	-2,793.16	464.03	2,794.85	0.00	0.00	0.00



Database:	EDM 5000.14 Single User Db	Local Co-ordinate Reference:	Well: PLU 20 Brushy Draw 122H 4/5
Company:	XTO Energy	TVD Reference:	GL 3158' + 31' KB @ 3189.00usft (Nabors F34)
Project:	Eddy County, NM	MD Reference:	GL 3158' + 31' KB @ 3189.00usft (Nabors F34)
Site:	PLU 20 Brushy Draw	North Reference:	Grid
Well:	PLU 20 Brushy Draw 122H 4/5	Survey Calculation Method:	Minimum Curvature
Wellbore:	Wellbore #1		
Design:	plan1		

Planned Survey										
Measured Depth (usft)	Inclination (°)	Azimuth (°)	Vertical Depth (usft)	+N-S (usft)	+E-W (usft)	Vertical Section (usft)	Dogleg Rate (°/100usft)	Build Rate (°/100usft)	Turn Rate (°/100usft)	
13,900.00	90.00	179.79	11,131.00	-2,893.16	464.39	2,894.85	0.00	0.00	0.00	
14,000.00	90.00	179.79	11,131.00	-2,993.16	464.76	2,994.85	0.00	0.00	0.00	
14,100.00	90.00	179.79	11,131.00	-3,093.16	465.13	3,094.85	0.00	0.00	0.00	
14,200.00	90.00	179.79	11,131.00	-3,193.16	465.49	3,194.85	0.00	0.00	0.00	
14,300.00	90.00	179.79	11,131.00	-3,293.16	465.86	3,294.85	0.00	0.00	0.00	
14,400.00	90.00	179.79	11,131.00	-3,393.16	466.23	3,394.85	0.00	0.00	0.00	
14,500.00	90.00	179.79	11,131.00	-3,493.16	466.59	3,494.85	0.00	0.00	0.00	
14,600.00	90.00	179.79	11,131.00	-3,593.16	466.96	3,594.85	0.00	0.00	0.00	
14,700.00	90.00	179.79	11,131.00	-3,693.16	467.33	3,694.85	0.00	0.00	0.00	
14,800.00	90.00	179.79	11,131.00	-3,793.16	467.69	3,794.85	0.00	0.00	0.00	
14,900.00	90.00	179.79	11,131.00	-3,893.16	468.06	3,894.85	0.00	0.00	0.00	
15,000.00	90.00	179.79	11,131.00	-3,993.16	468.43	3,994.85	0.00	0.00	0.00	
15,100.00	90.00	179.79	11,131.00	-4,093.16	468.79	4,094.85	0.00	0.00	0.00	
15,200.00	90.00	179.79	11,131.00	-4,193.15	469.16	4,194.85	0.00	0.00	0.00	
15,300.00	90.00	179.79	11,131.00	-4,293.15	469.53	4,294.85	0.00	0.00	0.00	
15,400.00	90.00	179.79	11,131.00	-4,393.15	469.89	4,394.85	0.00	0.00	0.00	
15,500.00	90.00	179.79	11,131.00	-4,493.15	470.26	4,494.85	0.00	0.00	0.00	
15,600.00	90.00	179.79	11,131.00	-4,593.15	470.63	4,594.85	0.00	0.00	0.00	
15,700.00	90.00	179.79	11,131.00	-4,693.15	470.99	4,694.85	0.00	0.00	0.00	
15,800.00	90.00	179.79	11,131.00	-4,793.15	471.36	4,794.85	0.00	0.00	0.00	
15,900.00	90.00	179.79	11,131.00	-4,893.15	471.73	4,894.85	0.00	0.00	0.00	
16,000.00	90.00	179.79	11,131.00	-4,993.15	472.09	4,994.85	0.00	0.00	0.00	
16,100.00	90.00	179.79	11,131.00	-5,093.15	472.46	5,094.85	0.00	0.00	0.00	
16,200.00	90.00	179.79	11,131.00	-5,193.15	472.83	5,194.85	0.00	0.00	0.00	
16,300.00	90.00	179.79	11,131.00	-5,293.15	473.19	5,294.85	0.00	0.00	0.00	
16,400.00	90.00	179.79	11,131.00	-5,393.15	473.56	5,394.85	0.00	0.00	0.00	
16,500.00	90.00	179.79	11,131.00	-5,493.15	473.93	5,494.85	0.00	0.00	0.00	
16,600.00	90.00	179.79	11,131.00	-5,593.15	474.29	5,594.85	0.00	0.00	0.00	
16,700.00	90.00	179.79	11,131.00	-5,693.14	474.66	5,694.85	0.00	0.00	0.00	
16,800.00	90.00	179.79	11,131.00	-5,793.14	475.03	5,794.85	0.00	0.00	0.00	
16,900.00	90.00	179.79	11,131.00	-5,893.14	475.39	5,894.85	0.00	0.00	0.00	
17,000.00	90.00	179.79	11,131.00	-5,993.14	475.76	5,994.85	0.00	0.00	0.00	
17,100.00	90.00	179.79	11,131.00	-6,093.14	476.13	6,094.85	0.00	0.00	0.00	
17,200.00	90.00	179.79	11,131.00	-6,193.14	476.49	6,194.85	0.00	0.00	0.00	
17,300.00	90.00	179.79	11,131.00	-6,293.14	476.86	6,294.85	0.00	0.00	0.00	
17,400.00	90.00	179.79	11,131.00	-6,393.14	477.22	6,394.85	0.00	0.00	0.00	
17,500.00	90.00	179.79	11,131.00	-6,493.14	477.59	6,494.85	0.00	0.00	0.00	
17,600.00	90.00	179.79	11,131.00	-6,593.14	477.96	6,594.85	0.00	0.00	0.00	
17,700.00	90.00	179.79	11,131.00	-6,693.14	478.32	6,694.85	0.00	0.00	0.00	
17,800.00	90.00	179.79	11,131.00	-6,793.14	478.69	6,794.85	0.00	0.00	0.00	
17,900.00	90.00	179.79	11,131.00	-6,893.14	479.06	6,894.85	0.00	0.00	0.00	
18,000.00	90.00	179.79	11,131.00	-6,993.14	479.42	6,994.85	0.00	0.00	0.00	
18,100.00	90.00	179.79	11,131.00	-7,093.14	479.79	7,094.85	0.00	0.00	0.00	
18,200.00	90.00	179.79	11,131.00	-7,193.13	480.16	7,194.85	0.00	0.00	0.00	
18,300.00	90.00	179.79	11,131.00	-7,293.13	480.52	7,294.85	0.00	0.00	0.00	
18,400.00	90.00	179.79	11,131.00	-7,393.13	480.89	7,394.85	0.00	0.00	0.00	
18,500.00	90.00	179.79	11,131.00	-7,493.13	481.26	7,494.85	0.00	0.00	0.00	
18,600.00	90.00	179.79	11,131.00	-7,593.13	481.62	7,594.85	0.00	0.00	0.00	
18,700.00	90.00	179.79	11,131.00	-7,693.13	481.99	7,694.85	0.00	0.00	0.00	
18,800.00	90.00	179.79	11,131.00	-7,793.13	482.36	7,794.85	0.00	0.00	0.00	
18,900.00	90.00	179.79	11,131.00	-7,893.13	482.72	7,894.85	0.00	0.00	0.00	
19,000.00	90.00	179.79	11,131.00	-7,993.13	483.09	7,994.85	0.00	0.00	0.00	

Database:	EDM 5000.14 Single User Db	Local Co-ordinate Reference:	Well PLU 20 Brushy Draw 122H 4/5
Company:	XTO Energy	TVD Reference:	GL 3158' + 31' KB @ 3189.00usft (Nabors F34)
Project:	Eddy County, NM	MD Reference:	GL 3158' + 31' KB @ 3189.00usft (Nabors F34)
Site:	PLU 20 Brushy Draw	North Reference:	Grid
Well:	PLU 20 Brushy Draw 122H 4/5	Survey Calculation Method:	Minimum Curvature
Wellbore:	Wellbore #1		
Design:	plan1		

Planned Survey										
Measured Depth (usft)	Inclination (°)	Azimuth (°)	Vertical Depth (usft)	+N/-S (usft)	+E/-W (usft)	Vertical Section (usft)	Dogleg Rate (°/100usft)	Build Rate (°/100usft)	Turn Rate (°/100usft)	
19,100.00	90.00	179.79	11,131.00	-8,093.13	483.46	8,094.85	0.00	0.00	0.00	
19,200.00	90.00	179.79	11,131.00	-8,193.13	483.82	8,194.85	0.00	0.00	0.00	
19,300.00	90.00	179.79	11,131.00	-8,293.13	484.19	8,294.85	0.00	0.00	0.00	
19,400.00	90.00	179.79	11,131.00	-8,393.13	484.56	8,394.85	0.00	0.00	0.00	
19,500.00	90.00	179.79	11,131.00	-8,493.13	484.92	8,494.85	0.00	0.00	0.00	
19,600.00	90.00	179.79	11,131.00	-8,593.13	485.29	8,594.85	0.00	0.00	0.00	
19,700.00	90.00	179.79	11,131.00	-8,693.12	485.66	8,694.85	0.00	0.00	0.00	
19,800.00	90.00	179.79	11,131.00	-8,793.12	486.02	8,794.85	0.00	0.00	0.00	
19,900.00	90.00	179.79	11,131.00	-8,893.12	486.39	8,894.85	0.00	0.00	0.00	
20,000.00	90.00	179.79	11,131.00	-8,993.12	486.76	8,994.85	0.00	0.00	0.00	
20,100.00	90.00	179.79	11,131.00	-9,093.12	487.12	9,094.85	0.00	0.00	0.00	
20,200.00	90.00	179.79	11,131.00	-9,193.12	487.49	9,194.85	0.00	0.00	0.00	
20,300.00	90.00	179.79	11,131.00	-9,293.12	487.86	9,294.85	0.00	0.00	0.00	
20,400.00	90.00	179.79	11,131.00	-9,393.12	488.22	9,394.85	0.00	0.00	0.00	
20,500.00	90.00	179.79	11,131.00	-9,493.12	488.59	9,494.85	0.00	0.00	0.00	
20,600.00	90.00	179.79	11,131.00	-9,593.12	488.96	9,594.85	0.00	0.00	0.00	
20,700.00	90.00	179.79	11,131.00	-9,693.12	489.32	9,694.85	0.00	0.00	0.00	
20,800.00	90.00	179.79	11,131.00	-9,793.12	489.69	9,794.85	0.00	0.00	0.00	
20,900.00	90.00	179.79	11,131.00	-9,893.12	490.06	9,894.85	0.00	0.00	0.00	
21,000.00	90.00	179.79	11,131.00	-9,993.12	490.42	9,994.85	0.00	0.00	0.00	
21,100.00	90.00	179.79	11,131.00	-10,093.12	490.79	10,094.85	0.00	0.00	0.00	
21,200.00	90.00	179.79	11,131.00	-10,193.11	491.16	10,194.85	0.00	0.00	0.00	
21,300.00	90.00	179.79	11,131.00	-10,293.11	491.52	10,294.85	0.00	0.00	0.00	
21,400.00	90.00	179.79	11,131.00	-10,393.11	491.89	10,394.85	0.00	0.00	0.00	
21,500.00	90.00	179.79	11,131.00	-10,493.11	492.26	10,494.85	0.00	0.00	0.00	
21,600.00	90.00	179.79	11,131.00	-10,593.11	492.62	10,594.85	0.00	0.00	0.00	
21,627.58	90.00	179.79	11,131.00	-10,620.69	492.72	10,622.43	0.00	0.00	0.00	
PLU 20 Brushy Draw 122H LTP										
21,700.00	90.00	179.79	11,131.00	-10,693.11	492.99	10,694.85	0.00	0.00	0.00	
21,757.58	90.00	179.79	11,131.00	-10,750.69	493.20	10,752.43	0.00	0.00	0.00	
TD at 21757.59 MD - PLU 20 Brushy Draw 122H BHL										

Design Targets										
Target Name	Dip Angle (°)	Dip Dir. (°)	TVD (usft)	+N/-S (usft)	+E/-W (usft)	Northing (usft)	Easting (usft)	Latitude	Longitude	
PLU 20 Brushy Draw 12 - hit/miss target - Shape - Point	0.00	0.00	11,131.00	-10,620.69	493.00	393,025.00	631,618.30	32° 4' 47.384 N	103° 54' 30.182 W	- plan misses target center by 0.28usft at 21627.58usft MD (11131.00 TVD, -10620.69 N, 492.72 E)
PLU 20 Brushy Draw 12 - plan hits target center - Rectangle (sides W100.00 H10,096.08 D30.00)	0.00	0.00	11,131.00	-10,750.69	493.20	392,895.00	631,618.50	32° 4' 46.097 N	103° 54' 30.186 W	
PLU 20 Brushy Draw 12 - plan misses target center by 2.79usft at 11661.50usft MD (11131.00 TVD, -654.68 N, 456.19 E) - Point	0.00	0.00	11,131.00	-654.69	453.40	402,991.00	631,578.70	32° 6' 26.012 N	103° 54' 30.186 W	



Database:	EDM 5000.14 Single User Db	Local Co-ordinate Reference:	Well PLU 20 Brushy Draw 122H 4/5
Company:	XTO Energy	TVD Reference:	GL 3158' + 31' KB @ 3189.00usft (Nabors F34)
Project:	Eddy County, NM	MD Reference:	GL 3158' + 31' KB @ 3189.00usft (Nabors F34)
Site:	PLU 20 Brushy Draw	North Reference:	Grid
Well:	PLU 20 Brushy Draw 122H 4/5	Survey Calculation Method:	Minimum Curvature
Wellbore:	Wellbore #1		
Design:	plan 1		

Formations						
Measured Depth (usft)	Vertical Depth (usft)	Name	Lithology	Dip (°)	Dip Direction (°)	
609.00	609.00	RSLR		0.00		
696.00	696.00	T/Salt		0.00		
2,098.00	2,098.00	CSTL		0.00		
3,397.00	3,397.00	Salt B		0.00		
3,587.00	3,587.00	DLWR		0.00		
3,612.00	3,612.00	BLCN		0.00		
4,515.00	4,515.00	CYCN		0.00		
6,102.00	6,102.00	BYCN		0.00		
7,173.00	7,173.00	BBYCN		0.00		
7,433.00	7,433.00	BSPG LM		0.00		
7,559.00	7,559.00	BSPG Avln SS		0.00		
7,574.00	7,574.00	BSPG U Avln SH		0.00		
7,970.00	7,970.00	BSPG L Avln SH		0.00		
8,354.00	8,354.00	BSPG1 LM		0.00		
8,378.00	8,378.00	BSPG1		0.00		
8,807.00	8,807.00	BSPG2 LM		0.00		
9,200.00	9,200.00	BSPG2		0.00		
9,509.00	9,509.00	BSPG3 LM		0.00		
9,849.00	9,849.00	BSPG Hrky		0.00		
9,879.00	9,879.00	BSPG3 SH		0.00		
10,092.00	10,092.00	BSPG3 LM Lwr		0.00		
10,133.00	10,133.00	BSPG3 SH Lwr		0.00		
10,289.00	10,289.00	BSPG3		0.00		
10,618.57	10,614.00	BSPG3 RH		0.00		
10,696.81	10,685.00	WFMP		0.00		
10,723.37	10,708.00	WFMP X		0.00		
10,821.43	10,787.00	WFMP Y		0.00		
10,864.00	10,818.00	WFMP A		0.00		
11,150.34	10,999.00	WFMP A Lower		0.00		

Plan Annotations					
Measured Depth (usft)	Vertical Depth (usft)	Local Coordinates		Comment	
		+N/-S (usft)	+E/-W (usft)		
10,410.12	10,410.12	0.00	0.00	Start Build 10.00	
10,860.12	10,815.26	-57.40	157.69	Start DLS 10.00 TFO 75.41	
11,618.73	11,131.00	-611.91	456.03	LP - Start 10138.86 hold at 11618.73 MD	
21,757.58	11,131.00	-10,750.69	493.20	TD at 21757.59 MD	

PECOS DISTRICT DRILLING CONDITIONS OF APPROVAL

OPERATOR'S NAME:	XTO Permian Operating, LLC
LEASE NO.:	NMLC-0064894
WELL NAME & NO.:	Poker Lake Unit 20 BD 122H
SURFACE HOLE FOOTAGE:	0330' FSL & 0540' FWL
BOTTOM HOLE FOOTAGE:	0200' FSL & 0990' FWL Sec. 32, T. 25 S., R 30 E.
LOCATION:	Section 20, T. 25 S., R 30 E., NMPM
COUNTY:	Eddy County, New Mexico

Commercial Well Determination

A commercial well determination shall be submitted after production has been established for at least six months.

Unit Wells

The well sign for a unit well shall include the unit number in addition to the surface and bottom hole lease numbers. This also applies to participating area numbers. If a participating area has not been established, the operator can use the general unit designation, but will replace the unit number with the participating area number when the sign is replaced.

A. DRILLING OPERATIONS REQUIREMENTS

The BLM is to be notified in advance for a representative to witness:

- a. Spudding well (minimum of 24 hours)
- b. Setting and/or Cementing of all casing strings (minimum of 4 hours)
- c. BOPE tests (minimum of 4 hours)

Eddy County

Call the Carlsbad Field Office, 620 East Greene St., Carlsbad, NM 88220,
(575) 361-2822

1. A Hydrogen Sulfide (H₂S) Drilling Plan shall be activated 500 feet prior to drilling into the **Delaware** formation. **As a result, the Hydrogen Sulfide area must meet Onshore Order 6 requirements, which includes equipment and personnel/public protection items. If Hydrogen Sulfide is encountered, please provide measured values and formations to the BLM.**
2. Unless the production casing has been run and cemented or the well has been properly plugged, the drilling rig shall not be removed from over the hole without prior approval. **If the drilling rig is removed without approval – an Incident of Non-Compliance will be written and will be a “Major” violation.**

3. **The operator has proposed to drill multiple wells utilizing a skid/walking rig. Operator shall secure the wellbore on the current well, after installing and testing the wellhead, by installing a blind flange of like pressure rating to the wellhead and a pressure gauge that can be monitored while drilling is performed on the other wells.**
4. **Floor controls are required for 3M or Greater systems. These controls will be on the rig floor, unobstructed, readily accessible to the driller and will be operational at all times during drilling and/or completion activities. Rig floor is defined as the area immediately around the rotary table; the area immediately above the substructure on which the draw works is located, this does not include the dog house or stairway area.**
5. **The record of the drilling rate along with the GR/N well log run from TD to surface (horizontal well – vertical portion of hole) shall be submitted to the BLM office as well as all other logs run on the borehole 30 days from completion. If available, a digital copy of the logs is to be submitted in addition to the paper copies. The Rustler top and top and bottom of Salt are to be recorded on the Completion Report.**

B. CASING

Changes to the approved APD casing program need prior approval if the items substituted are of lesser grade or different casing size or are Non-API. The Operator can exchange the components of the proposal with that of superior strength (i.e. changing from J-55 to N-80, or from 36# to 40#). Changes to the approved cement program need prior approval if the altered cement plan has less volume or strength or if the changes are substantial (i.e. Multistage tool, ECP, etc.). The initial wellhead installed on the well will remain on the well with spools used as needed.

Centralizers required on surface casing per Onshore Order 2.III.B.1.f.

Wait on cement (WOC) for Water Basin:

After cementing but before commencing any tests, the casing string shall stand cemented under pressure until both of the following conditions have been met: 1) cement reaches a minimum compressive strength of 500 psi at the shoe, 2) until cement has been in place at least 8 hours. WOC time will be recorded in the driller's log. See individual casing strings for details regarding lead cement slurry requirements.

Provide compressive strengths including hours to reach required 500 pounds compressive strength prior to cementing each casing string. Have well specific cement details onsite prior to pumping the cement for each casing string.

No pea gravel permitted for remedial or fall back remedial without prior authorization from the BLM engineer.

Possibility of water flows in the Salado and Castile.

Possibility of lost circulation in the Red beds, Rustler, and Delaware.

Abnormal pressures may be encountered upon penetrating the 3rd Bone Spring Sandstone and all subsequent formations.

1. The 16 inch surface casing shall be set at approximately 700 feet (**in a competent bed below the Magenta Dolomite, which is a Member of the Rustler, and if salt is encountered, set casing at least 25 feet above the salt**) and cemented to the surface.
 - a. If cement does not circulate to the surface, the appropriate BLM office shall be notified and a temperature survey utilizing an electronic type temperature survey with surface log readout will be used or a cement bond log shall be run to verify the top of the cement. Temperature survey will be run a minimum of six hours after pumping cement and ideally between 8-10 hours after completing the cement job.
 - b. **Wait on cement (WOC) time for a primary cement job is to include the lead cement slurry.**
 - c. Wait on cement (WOC) time for a remedial job will be a minimum of 4 hours after bringing cement to surface or 500 pounds compressive strength, whichever is greater.
 - d. If cement falls back, remedial cementing will be done prior to drilling out that string.

11-3/4" 1st Intermediate casing shall be kept fluid filled while running into hole to meet BLM minimum collapse requirements.

2. The minimum required fill of cement behind the 11-3/4 inch 1st intermediate casing, which shall be set at approximately 3645 feet, is:

Cement to surface. If cement does not circulate see B.1.a, c-d above.

Formation below the 11-3/4" shoe to be tested according to Onshore Order 2.III.B.1.i. Test to be done as a mud equivalency test using the mud weight necessary for the pore pressure of the formation below the shoe (not the mud weight required to prevent dissolving the salt formation) and the mud weight for the bottom of the hole. Report results to BLM office.

8-5/8" 2nd Intermediate casing shall be kept fluid filled while running into hole to meet BLM minimum collapse requirements.

3. The minimum required fill of cement behind the 8-5/8 inch 2nd intermediate casing is:

Operator has proposed DV tool at depth of 3695', but will adjust cement proportionately if moved. DV tool shall be set a minimum of 50' below previous shoe and a minimum of 200' above current shoe. Operator shall submit sundry if DV tool depth cannot be set in this range. If an ECP is used, it is to be set a minimum of 50' below the shoe to provide cement across the shoe. If it cannot be set below the shoe, a CBL shall be run to verify cement coverage.

a. First stage to DV tool:

- Cement to circulate. If cement does not circulate, contact the appropriate BLM office before proceeding with second stage cement job. Operator should have plans as to how they will achieve circulation on the next stage.

b. Second stage above DV tool:

- Cement should tie-back at least 200 feet into previous casing string. Operator shall provide method of verification.

Formation below the 8-5/8" shoe to be tested according to Onshore Order 2.III.B.1.i. Test to be done as a mud equivalency test using the mud weight necessary for the pore pressure of the formation below the shoe and the mud weight for the bottom of the hole. Report results to BLM office.

Centralizers required through the curve and a minimum of one every other joint.

4. The minimum required fill of cement behind the 5-1/2 inch production casing is:

- Cement should tie-back at least 200 feet into previous casing string. Operator shall provide method of verification.

5. If hardband drill pipe is rotated inside casing, returns will be monitored for metal. If metal is found in samples, drill pipe will be pulled and rubber protectors which have a larger diameter than the tool joints of the drill pipe will be installed prior to continuing drilling operations.

C. PRESSURE CONTROL

1. All blowout preventer (BOP) and related equipment (BOPE) shall comply with well control requirements as described in Onshore Oil and Gas Order No. 2 and API 53.

2. Variance approved to use flex line from BOP to choke manifold. Check condition of flexible line from BOP to choke manifold, replace if exterior is damaged or if line fails test. Line to be as straight as possible with no hard bends and is to be anchored according to Manufacturer's requirements. The flexible hose can be exchanged with a hose of equal size and equal or greater pressure rating. **Anchor requirements, specification sheet and hydrostatic pressure test certification matching the hose in service, to be onsite for review. These documents shall be posted in the company man's trailer and on the rig floor.** If the BLM inspector questions the straightness of the hose, a BLM engineer will be contacted and will review in the field or via picture supplied by inspector to determine if changes are required (operator shall expect delays if this occurs).
3. Minimum working pressure of the blowout preventer (BOP) and related equipment (BOPE) required for drilling below the surface casing shoe shall be **2000 (2M) psi.**
4. **Operator has proposed a multi-bowl wellhead assembly. This assembly will only be tested when installed on the 11-3/4" 1st intermediate casing. Minimum working pressure of the blowout preventer (BOP) and related equipment (BOPE) required for drilling below the 11-3/4" 1st intermediate casing shoe shall be 5000 (5M) psi.**
 - a. Wellhead shall be installed by manufacturer's representatives, submit documentation with subsequent sundry.
 - b. If the welding is performed by a third party, the manufacturer's representative shall monitor the temperature to verify that it does not exceed the maximum temperature of the seal.
 - c. Manufacturer representative shall install the test plug for the initial BOP test.
 - d. Operator shall perform the 8-5/8" intermediate casing integrity test to 70% of the casing burst. This will test the multi-bowl seals.
 - e. If the cement does not circulate and one inch operations would have been possible with a standard wellhead, the well head shall be cut off, cementing operations performed and another wellhead installed.

5M system requires an HCR valve, remote kill line and annular to match. The remote kill line is to be installed prior to testing the system and tested to stack pressure.

5. The appropriate BLM office shall be notified a minimum of 4 hours in advance for a representative to witness the tests.
 - a. In a water basin, for all casing strings utilizing slips, these are to be set as soon as the crew and rig are ready and any fallback cement remediation has been done. The casing cut-off and BOP installation can be initiated four hours after installing the slips, which will be approximately six hours after bumping the plug. For those casing strings not using slips, the minimum wait time before cut-off is eight hours after bumping the plug. BOP/BOPE testing can begin after cut-off or once cement reaches 500 psi compressive strength (including lead when specified), whichever is greater. However, if the float does not hold, cut-off cannot be initiated until cement reaches 500 psi compressive strength (including lead when specified).
 - b. The tests shall be done by an independent service company utilizing a test plug **not a cup or J-packer**.
 - c. The test shall be run on a 5000 psi chart for a 2-3M BOP/BOP, on a 10000 psi chart for a 5M BOP/BOPE and on a 15000 psi chart for a 10M BOP/BOPE. If a linear chart is used, it shall be a one hour chart. A circular chart shall have a maximum 2 hour clock. If a twelve hour or twenty-four hour chart is used, tester shall make a notation that it is run with a two hour clock.
 - d. The results of the test shall be reported to the appropriate BLM office.
 - e. All tests are required to be recorded on a calibrated test chart. **A copy of the BOP/BOPE test chart and a copy of independent service company test will be submitted to the appropriate BLM office.**
 - f. The BOP/BOPE test shall include a low pressure test from 250 to 300 psi. The test will be held for a minimum of 10 minutes if test is done with a test plug and 30 minutes without a test plug. This test shall be performed prior to the test at full stack pressure.
 - g. BOP/BOPE must be tested by an independent service company within 500 feet of the top of the **Wolfcamp** formation if the time between the setting of the intermediate casing and reaching this depth exceeds 20 days. This test does not exclude the test prior to drilling out the casing shoe as per Onshore Order No. 2.

D. DRILLING MUD

Mud system monitoring equipment, with derrick floor indicators and visual and audio alarms, shall be operating before drilling into the **Wolfcamp** formation, and shall be used until production casing is run and cemented.

E. DRILL STEM TEST

If drill stem tests are performed, Onshore Order 2.III.D shall be followed.

F. WASTE MATERIAL AND FLUIDS

All waste (i.e. drilling fluids, trash, salts, chemicals, sewage, gray water, etc.) created as a result of drilling operations and completion operations shall be safely contained and disposed of properly at a waste disposal facility. No waste material or fluid shall be disposed of on the well location or surrounding area.

Porto-johns and trash containers will be on-location during fracturing operations or any other crew-intensive operations.

JAM 080719