

UNITED STATES  
DEPARTMENT OF THE INTERIOR  
BUREAU OF LAND MANAGEMENT

**Operator**

FORM APPROVED  
OMB NO. 1004-0137  
Expires: January 31, 2018

**SUNDRY NOTICES AND REPORTS ON WELLS**  
Do not use this form for proposals to drill or to re-enter an abandoned well. Use form 3160-3 (APD) for such proposals.

REC'D MIDLAND  
JAN 23 2020

**SUBMIT IN TRIPLICATE - Other instructions on page 2**

1. Type of Well <input type="checkbox"/> Oil Well <input checked="" type="checkbox"/> Gas Well <input type="checkbox"/> Other		5. Lease Serial No. NMLC063875A
2. Name of Operator XTO PERMIAN OPERATING LLC Contact: KELLY KARDOS E-Mail: kelly_kardos@xtoenergy.com		6. If Indian, Allottee or Tribe Name
3a. Address 6401 HOLIDAY HILL ROAD BLDG 5 MIDLAND, TX 79707	3b. Phone No. (include area code) Ph: 432-620-4374	7. If Unit or CA/Agreement, Name and/or No. 891000303X
4. Location of Well (Footage, Sec., T., R., M. or Survey Description) Sec 27 T25S R30E SWNW 2510FNL 693FWL 32.101524 N Lat, 103.875336 W Lon		8. Well Name and No. POKER LAKE UNIT 27 BD 152H
		9. API Well No. 30-015-46257-00-X1
		10. Field and Pool or Exploratory Area PURPLE SAGE-WOLFCAMP (GAS)
		11. County or Parish, State EDDY COUNTY, NM

**12. CHECK THE APPROPRIATE BOX(ES) TO INDICATE NATURE OF NOTICE, REPORT, OR OTHER DATA.**

TYPE OF SUBMISSION	TYPE OF ACTION			
<input checked="" type="checkbox"/> Notice of Intent	<input type="checkbox"/> Acidize	<input type="checkbox"/> Deepen	<input type="checkbox"/> Production (Start/Resume)	<input type="checkbox"/> Water Shut-Off
<input type="checkbox"/> Subsequent Report	<input type="checkbox"/> Alter Casing	<input type="checkbox"/> Hydraulic Fracturing	<input type="checkbox"/> Reclamation	<input type="checkbox"/> Well Integrity
<input type="checkbox"/> Final Abandonment Notice	<input type="checkbox"/> Casing Repair	<input type="checkbox"/> New Construction	<input type="checkbox"/> Recomplete	<input checked="" type="checkbox"/> Other
	<input type="checkbox"/> Change Plans	<input type="checkbox"/> Plug and Abandon	<input type="checkbox"/> Temporarily Abandon	Change to Original APD
	<input type="checkbox"/> Convert to Injection	<input type="checkbox"/> Plug Back	<input type="checkbox"/> Water Disposal	

13. Describe Proposed or Completed Operation: Clearly state all pertinent details, including estimated starting date of any proposed work and approximate duration thereof. If the proposal is to deepen directionally or recompleat horizontally, give subsurface locations and measured and true vertical depths of all pertinent markers and zones. Attach the Bond under which the work will be performed or provide the Bond No. on file with BLM/BIA. Required subsequent reports must be filed within 30 days following completion of the involved operations. If the operation results in a multiple completion or recompleat in a new interval, a Form 3160-4 must be filed once testing has been completed. Final Abandonment Notices must be filed only after all requirements, including reclamation, have been completed and the operator has determined that the site is ready for final inspection.

XTO Permian Operating, LLC requests permission to make the following changes to the original APD:

Change the casing/cement design per the attached drilling program.

XTO requests to not utilize centralizers in the curve and lateral.

XTO requests a variance to be able to batch drill this well if necessary. In doing so, XTO will set each casing string and ensure that the well is cemented properly and the well is static. With floats holding, no pressure on the csg annulus, and the installation of a 10K TA cap as per GE recommendations, XTO will contact the BLM to skid the rig to drill the remaining wells on the pad. Once surface and intermediate strings are all completed, XTO will begin drilling the production hole on each of the wells.

ATTACHED FOR  
CONDITIONS OF APPROVAL

RECEIVED  
JAN 27 2020

EMNRD-OCD ARTESIA

14. I hereby certify that the foregoing is true and correct.

Electronic Submission #497781 verified by the BLM Well Information System  
For XTO PERMIAN OPERATING LLC, sent to the Carlsbad  
Committed to AFMSS for processing by JENNIFER SANCHEZ on 01/07/2020 (20JA000715E)

Name (Printed/Typed)	KELLY KARDOS	Title	REGULATORY COORDINATOR
Signature	(Electronic Submission)	Date	01/06/2020 APPROVED

THIS SPACE FOR FEDERAL OR STATE OFFICE USE

JAN 14 2020

Approved By	Title	Date

Conditions of approval, if any, are attached. Approval of this notice does not warrant or certify that the applicant holds legal or equitable title to those rights in the subject lease which would entitle the applicant to conduct operations thereon.

Office: BUREAU OF LAND MANAGEMENT  
ROSWELL FIELD OFFICE

Title 18 U.S.C. Section 1001 and Title 43 U.S.C. Section 1212, make it a crime for any person knowingly and willfully to make to any department or agency of the United States any false, fictitious or fraudulent statements or representations as to any matter within its jurisdiction.

(Instructions on page 2) **\*\* BLM REVISED \*\* BLM REVISED \*\* BLM REVISED \*\* BLM REVISED \*\* BLM REVISED \*\***

Accepted 2/4/20 ES

**Additional data for EC transaction #497781 that would not fit on the form**

**32. Additional remarks, continued**

Poker Lake Unit 27 BD 161H 30-015-46249  
Poker Lake Unit 27 BD 121H 30-015-46264  
Poker Lake Unit 27 BD 102H 30-015-46245  
Poker Lake Unit 27 BD 152H 30-015-46257  
Poker Lake Unit 27 BD 122H 30-015-46265

**Revisions to Operator-Submitted EC Data for Sundry Notice #497781**

	<b>Operator Submitted</b>	<b>BLM Revised (AFMSS)</b>
Sundry Type:	APDCH NOI	APDCH NOI
Lease:	NMLC063875A	NMLC063875A
Agreement:	NMNM71016X	891000303X (NMNM71016X)
Operator:	XTO PERMIAN OPERATING, LLC 6401 HOLIDAY HILL RD BLDG 5 MIDLAND, TX 79707 Ph: 432-620-4374	XTO PERMIAN OPERATING LLC 6401 HOLIDAY HILL ROAD BLDG 5 MIDLAND, TX 79707 Ph: 432.683 2277
Admin Contact:	KELLY KARDOS REGULATORY COORDINATOR E-Mail: kelly_kardos@xtoenergy.com  Ph: 432-620-4374	KELLY KARDOS REGULATORY COORDINATOR E-Mail: kelly_kardos@xtoenergy.com  Ph: 432-620-4374
Tech Contact:	KELLY KARDOS REGULATORY COORDINATOR E-Mail: kelly_kardos@xtoenergy.com  Ph: 432-620-4374	KELLY KARDOS REGULATORY COORDINATOR E-Mail: kelly_kardos@xtoenergy.com  Ph: 432-620-4374
Location:		
State:	NM	NM
County:	EDDY	EDDY
Field/Pool:	PURPLE SAGE WOLFCAMP	PURPLE SAGE-WOLFCAMP (GAS)
Well/Facility:	POKER LAKE UNIT 27 BD 152H Sec 27 T25S R30E Mer NMP SWNW 2510FNL 693FWL	POKER LAKE UNIT 27 BD 152H Sec 27 T25S R30E SWNW 2510FNL 693FWL 32.101524 N Lat, 103.875336 W Lon

**DRILLING PLAN: BLM COMPLIANCE**  
(Supplement to BLM 3160-3)

XTO Energy Inc.  
Poker Lake Unit 27 Brushy Draw 152H  
Projected TD: 27807' MD / 12071' TVD  
SHL: 2510' FNL & 693' FWL, Section 27, T25S, R30E  
BHL: 2440' FNL & 990' FWL, Section 10, T26S, R30E  
Eddy County, NM

**1. Geologic Name of Surface Formation**  
A. Quaternary

**2. Estimated Tops of Geological Markers & Depths of Anticipated Fresh Water, Oil or Gas**

Formation	Well Depth (TVD)	Water/Oil/Gas
Rustler	1061'	Water
Top of Salt	1351'	Water
Base of Salt	3641'	Water
Delaware	3856'	Water
Bone Spring	7661'	Water
1st Bone Spring Ss	8596'	Water/Oil/Gas
2nd Bone Spring Ss	9399'	Water/Oil/Gas
3rd Bone Spring Ss	10556'	Water/Oil/Gas
Wolfcamp Shale	10956'	Water/Oil/Gas
Wolfcamp A	11099'	Water/Oil/Gas
Wolfcamp E	12051'	Water/Oil/Gas
Target/Land Curve	12071'	Water/Oil/Gas

\*\*\* Hydrocarbons @ Brushy Canyon  
\*\*\* Groundwater depth 40' (per NM State Engineers Office).

No other formations are expected to yield oil, gas or fresh water in measurable volumes. The surface fresh water sands will be protected by setting 13 3/8" inch casing @ 1250' (101' above the salt) and circulating cement back to surface. The 9-5/8" intermediate casing will be set at 11250' and bring TOC back 200' inside the previous shoe. An 8-3/4 inch curve and lateral hole will be drilled to MD/TD and 5-1/2 inch casing will be set at TD and cemented back 500' into the 9-5/8" casing shoe.

**3. Casing Design**

Hole Size	Depth	OD Csg	Weight	Collar	Grade	New/Used	SF Burst	SF Collapse	SF Tension
17-1/2"	0' - 1250'	13 3/8"	68	STC	J-55	New	1.12	3.45	7.94
12-1/4"	0' - 11250'	9-5/8"	40	BTC	HCL-80	New	1.04	1.24	2.10
8-3/4 - 8-1/2"	0' - 27807'	5-1/2"	20	BTC	P-110	New	1.20	1.36	1.87

- XTO requests to not utilize centralizers in the curve and lateral
- 9-5/8" Collapse analyzed using 50% evacuation based on regional experience.
- 5-1/2" Tension calculated using vertical hanging weight plus the lateral weight multiplied by a friction factor of 0.35
- Test on Casing will be limited to 70% burst of the casing or 1500 psi, whichever is less

**Wellhead:**

Permanent Wellhead - GE RSH Multibowl System

A. Starting Head: 13-5/8" 10M top flange x 13-3/8" SOW bottom

B. Tubing Head: 13-5/8" 10M bottom flange x 7-1/16" 15M top flange

- Wellhead will be installed by manufacturer's representatives.
- Manufacturer will monitor welding process to ensure appropriate temperature of seal.
- Operator will test the 9-5/8" casing per BLM Onshore Order 2
- Wellhead Manufacturer representative will not be present for BOP test plug installation

#### 4. Cement Program

**Surface Casing: 13 3/8", 68 New J-55, STC casing to be set at +/- 1250'**

Lead: 700 sxs EconoCem-HLTRRC (mixed at 12.9 ppg, 1.87 ft<sup>3</sup>/sx, 10.13 gal/sx water)  
Tail: 300 sxs Halcem-C + 2% CaCl (mixed at 14.8 ppg, 1.35 ft<sup>3</sup>/sx, 6.39 gal/sx water)  
Compressives: 12-hr = 900 psi 24 hr = 1500 psi  
TOC @ Surface

**Intermediate Casing: 9-5/8", 40 New HCL-80, BTC casing to be set at +/- 11250'**  
ECP/DV Tool to be set at 6000'

##### 1st Stage

Lead: 1420 sxs EconoCem-HLTRRC (mixed at 12.9 ppg, 1.87 ft<sup>3</sup>/sx, 10.13 gal/sx water)  
Tail: 460 sxs Halcem-C + 2% CaCl (mixed at 14.8 ppg, 1.35 ft<sup>3</sup>/sx, 6.39 gal/sx water)  
Compressives: 12-hr = 900 psi 24 hr = 1500 psi

##### 2nd Stage

Lead: 1490 sxs EconoCem-HLTRRC (mixed at 12.9 ppg, 1.88 ft<sup>3</sup>/sx, 10.13 gal/sx water)  
Tail: 230 sxs Halcem-C + 2% CaCl (mixed at 14.8 ppg, 1.33 ft<sup>3</sup>/sx, 6.39 gal/sx water)  
Compressives: 12-hr = 900 psi 24 hr = 1500 psi

TOC @ 1000' *surface*

**Production Casing: 5-1/2", 20 New P-110, BTC casing to be set at +/- 27807'**

Tail: 3180 sxs VersaCem (mixed at 13.2 ppg, 1.61 ft<sup>3</sup>/sx, 8.38 gal/sx water)  
Compressives: 12-hr = 1375 psi 24 hr = 2285 psi

#### 5. Pressure Control Equipment

Once the permanent WH is installed on the 13 3/8" casing, the blow out preventer equipment (BOP) will consist of a 13-5/8" minimum 5M Hydral and a 13-5/8" minimum 10M 3-Ram BOP. MASP should not exceed 5504 psi. In any instance where 10M BOP is required by BLM; XTO requests a variance to utilize 5M annular with 10M ram preventers (a common BOP configuration, which allows use of 10M rams in unlikely event that pressures exceed 5M). Also a variance is requested to test the 5M annular to 70% of working pressure at 3500 psi.

All BOP testing will be done by an independent service company. Annular pressure tests will be limited to 70% of the working pressure. When nipping up on the 13 3/8", 10M bradenhead and flange, the BOP test will be limited to 10000 psi. All BOP tests will include a low pressure test as per BLM regulations. The 10M BOP diagrams are attached. Blind rams will be functioned tested each trip, pipe rams will be functioned tested each day.

A variance is requested to allow use of a flex hose as the choke line from the BOP to the Choke Manifold. If this hose is used, a copy of the manufacturer's certification and pressure test chart will be kept on the rig. Attached is an example of a certification and pressure test chart. The manufacturer does not require anchors.

XTO requests a variance to be able to batch drill this well if necessary. In doing so, XTO will set each casing string and ensure that the well is cemented properly and the well is static. With floats holding, no pressure on the csg annulus, and the installation of a 10K TA cap as per GE recommendations, XTO will contact the BLM to skid the rig to drill the remaining wells on the pad. Once surface and intermediate strings are all completed, XTO will begin drilling the production hole on each of the wells.

*10m BOP  
system  
Required.*

## 6. Proposed Mud Circulation System

INTERVAL	Hole Size	Mud Type	MW (ppg)	Viscosity (sec/qt)	Fluid Loss (cc)
0' - 1250'	17-1/2"	FW / Native	8.4-8.8	35-40	NC
1250' - 11250'	12-1/4"	Brine / Cut Brine / WBM	8.8-9.8	30-32	NC
11250' to 27807'	8-3/4"	Cut Brine / WBM / OBM	12.0-13.0	32-36	NC

The necessary mud products for weight addition and fluid loss control will be on location at all times. Spud with fresh water/native mud and set 13 3/8" surface casing, isolating the fresh water aquifer. Drill out from under 13-3/8" surface casing with a brine/oil direct emulsion water-based mud. Use fibrous materials as needed to control seepage and lost circulation. Pump viscous sweeps as needed for hole cleaning. Pump speed will be recorded on a daily drilling report after mudding up. A Pason or Totco will be used to detect changes in loss or gain of mud volume. A mud test will be performed every 24 hours to determine: density, viscosity, strength, filtration and pH as necessary. Use available solids controls equipment to help keep mud weight down after mud up. Rig up solids control equipment to operate as a closed loop system.

## 7. Auxiliary Well Control and Monitoring Equipment

- A. A Kelly cock will be in the drill string at all times.
- B. A full opening drill pipe stabbing valve having appropriate connections will be on the rig floor at all times.
- C. H2S monitors will be on location when drilling below the 13 3/8" casing.

## 8. Logging, Coring and Testing Program

Mud Logger: Mud Logging Unit (2 man) below intermediate casing.

Open hole logging will not be done on this well.

## 9. Abnormal Pressures and Temperatures / Potential Hazards

None Anticipated. BHT of 155 to 175 F is anticipated. No H2S is expected but monitors will be in place to detect any H2S occurrences. Should these circumstances be encountered the operator and drilling contractor are prepared to take all necessary steps to ensure safety of all personnel and environment. Lost circulation could occur but is not expected to be a serious problem in this area and hole seepage will be compensated for by additions of small amounts of LCM in the drilling fluid. The maximum anticipated bottom hole pressure for this well is 8160 psi.

## 10. Anticipated Starting Date and Duration of Operations

Road and location construction will begin after Santa Fe and BLM have approved the APD. Anticipated spud date will be as soon after Santa Fe and BLM approval and as soon as a rig will be available. Move in operations and drilling is expected to take 45 days. If production casing is run, an additional 30 days will be needed to complete well and construct surface facilities and/or lay flow lines in order to place well on production.

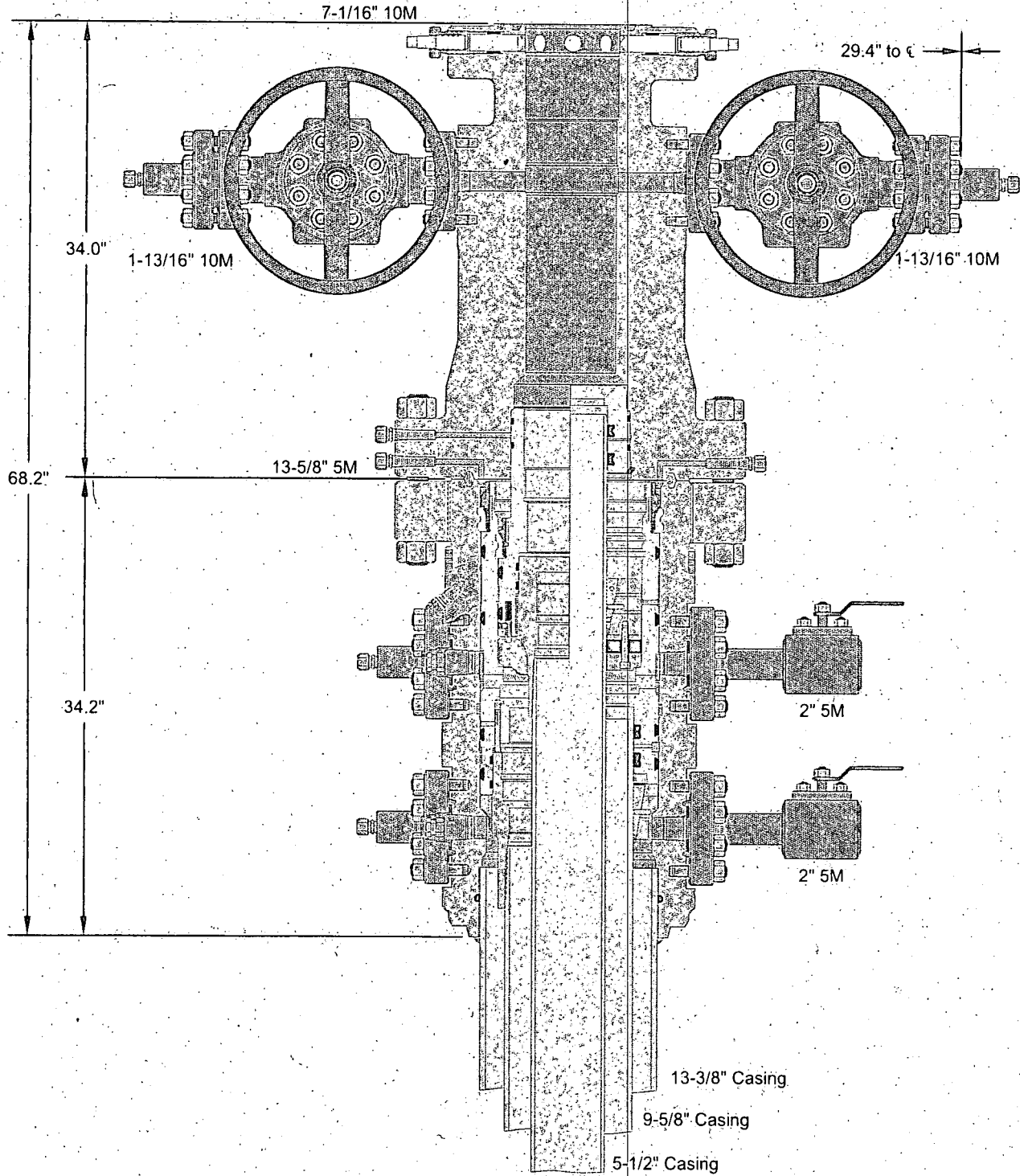

ALL DIMENSIONS ARE APPROXIMATE

This drawing is the property of GE Oil & Gas Pressure Control LP and is considered confidential. Unless otherwise approved in writing, neither it nor its contents may be used, copied, transmitted or reproduced except for the sole purpose of GE Oil & Gas Pressure Control LP.

XTO ENERGY, INC.

13-3/8" x 9-5/8" x 5-1/2" 10M RSH-2 Wellhead Assembly, With T-EBS-F Tubing Head

DRAWN	VJK	16FEB17
APPRV	KN	16FEB17

FOR REFERENCE ONLY  
DRAWING NO: 10012842

Fill Line

Flowline

5000# (5M) Annular /  
10000# Ram Preventer

5M Annular Preventer

10M Pipe Rams

10M Blind Rams

2" Minimum Kill Line

Kill Line

2 Valves and 1 Check  
Valve Minimum

3" Minimum Choke Line

Choke Line

Drilling  
Spool

2 Valves Minimum  
(1 Manual/1 Hydraulic)

10M Pipe Rams

Wellhead  
Assembly

10000# BOP  
XTO

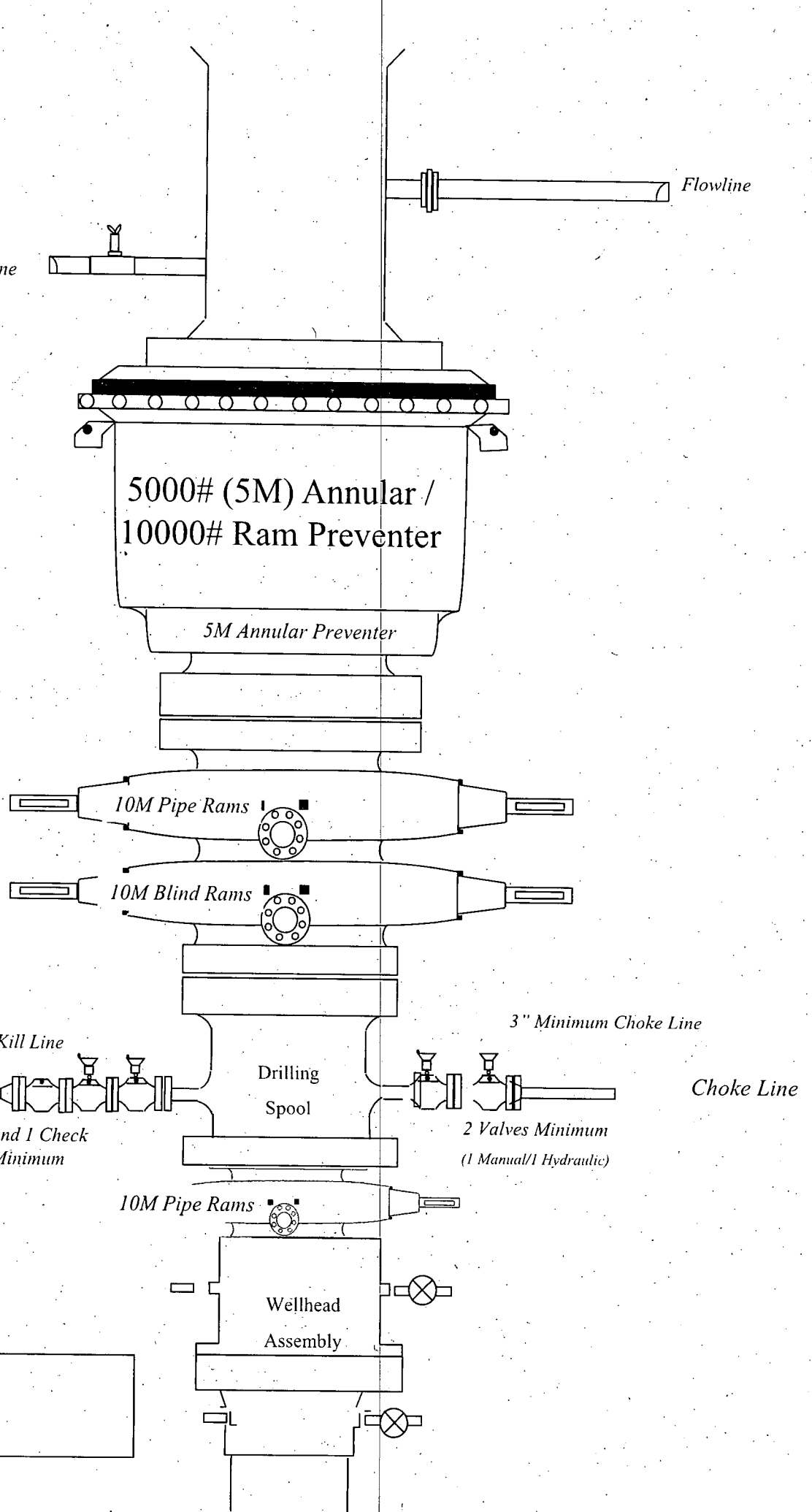
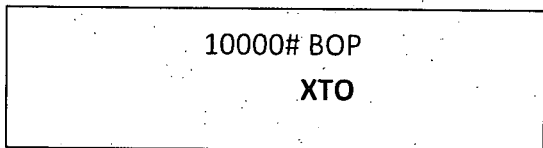



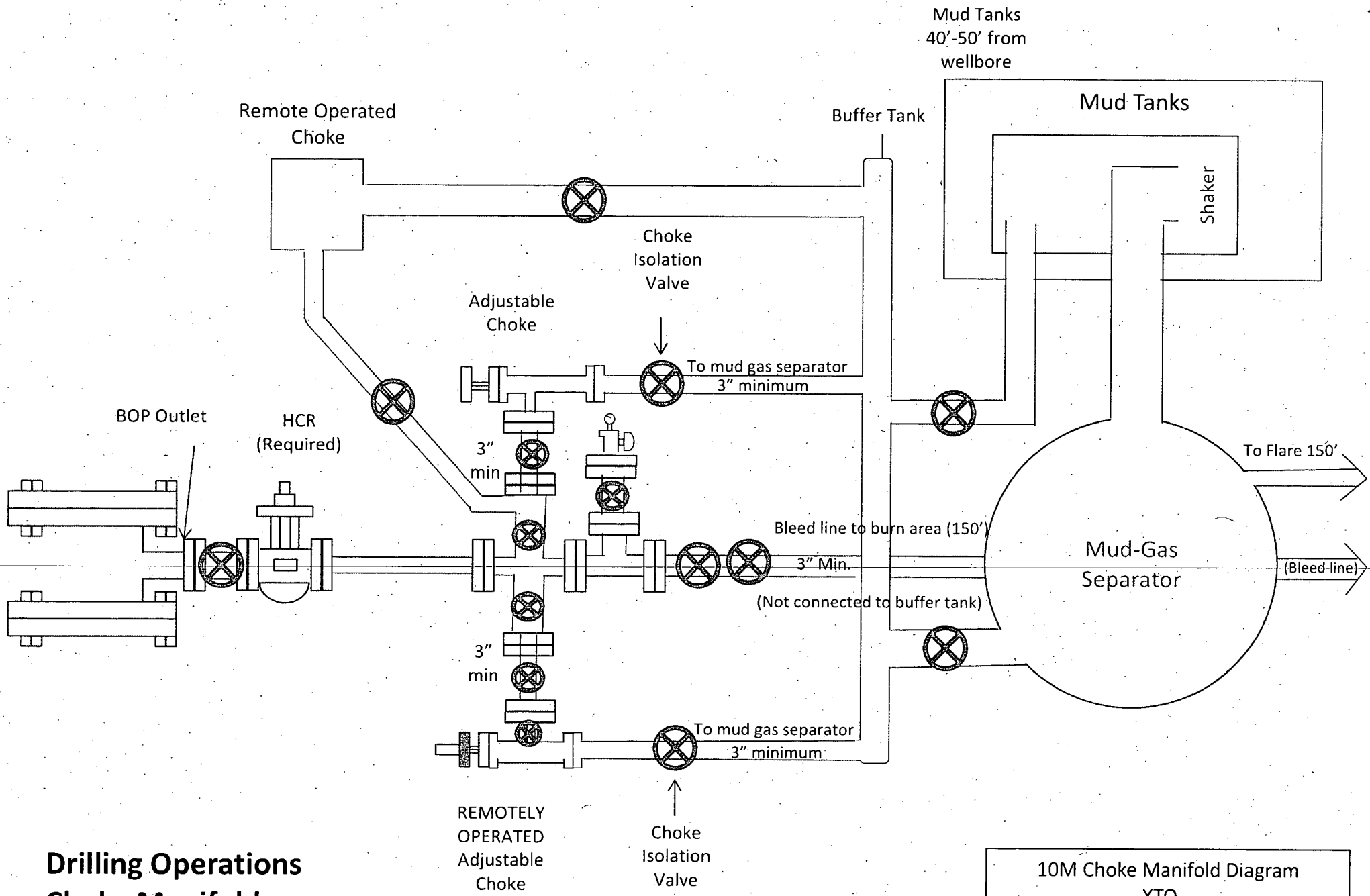

**Drilling Operations  
Choke Manifold  
10M Service**

10M Choke Manifold Diagram  
XTO

## 10,000 PSI Annular BOP Variance Request

XTO Energy/XTO Permian Op. request a variance to use a 5000 psi annular BOP with a 10,000 psi BOP stack. The component and compatibility tables along with the general well control plans demonstrate how the 5000 psi annular BOP will be protected from pressures that exceed its rated working pressure (RWP). The pressure at which the control of the wellbore is transferred from the annular preventer to another available preventer will not exceed 3500 psi (70% of the RWP of the 5000 psi annular BOPL).

### 1. Component and Preventer Compatibility Tables

The tables below outline the tubulars and the compatible preventers in use. This table, combined with the drilling fluid, documents that two barriers to flow will be maintained at all times.

8-1/2" Production Hole Section 10M psi Requirement					
Component	OD	Primary Preventer	RWP	Alternate Preventer(s)	RWP
Drillpipe	5.000" or 4.500"	Annular	5M	Upper 3.5"-5.5" VBR Lower 3.5"-5.5" VBR	10M 10M
HWDP	5.000" or 4.500"	Annular	5M	Upper 3.5"-5.5" VBR Lower 3.5"-5.5" VBR	10M 10M
Jars	6.500"	Annular	5M	-	-
DCs and MWD tools	6.500"-8.000"	Annular	5M	-	-
Mud Motor	6.750"-8.000"	Annular	5M	-	-
Production Casing	5-1/2"	Annular	5M	-	-
Open-Hole	-	Blind Rams	10M	-	-

## 2. Well Control Procedures

Below are the minimal high-level tasks prescribed to assure a proper shut-in while drilling, tripping, running casing, pipe out of the hole (open hole), and moving the BHA through the BOPs. At least one well control drill will be performed weekly per crew to demonstrate compliance with the procedure and well control plan. The well control drill will be recorded in the daily drilling log. The type of drill will be determined by the ongoing operations, but reasonable attempts will be made to vary the type of drill conducted (pit, trip, open hole, choke, etc.). This well control plan will be available for review by rig personnel in the XTO Energy/Permian Operating drilling supervisor's office on location and on the rig floor. All BOP equipment will be tested as per Onshore O&G Order No. 2 with the exception of the 5000 psi annular which will be tested to 70% of its RWP.

### General Procedure While Drilling

1. Sound alarm (alert crew)
2. Space out drill string
3. Shut down pumps (stop pumps and rotary)
4. Shut-in well (uppermost applicable BOP, typically annular preventer, first. HCR & choke will already be in the closed position.)
5. Confirm shut-in
6. Notify toolpusher/company representative
7. Read and record the following:
  - a. SIDPP & SICP
  - b. Pit gain
  - c. Time
8. Regroup and identify forward plan

9. If pressure has built or is anticipated during the kill to reach 70% or greater of the RWP of the annular preventer, confirm spacing and close the upper variable bore rams.

#### General Procedure While Tripping

1. Sound alarm (alert crew)
2. Stab full-opening safety valve & close
3. Space out drill string
4. Shut-in well (uppermost applicable BOP, typically annular preventer, first. HCR & choke will already be in the closed position.)
5. Confirm shut-in
6. Notify toolpusher/company representative
7. Read and record the following:
  - a. SIDPP & SICP
  - b. Pit gain
  - c. Time
8. Regroup and identify forward plan
9. If pressure has built or is anticipated during the kill to reach 70% of the RWP of the annular preventer, confirm spacing and close the upper variable bore rams.

#### General Procedure While Running Production Casing

1. Sound alarm (alert crew)
2. Stab crossover and full-opening safety valve and close
3. Space out string
4. Shut-in well (uppermost applicable BOP, typically annular preventer, first. HCR & choke will already be in the closed position.)
5. Confirm shut-in
6. Notify toolpusher/company representative
7. Read and record the following:
  - a. SIDPP & SICP
  - b. Pit gain
  - c. Time
8. Regroup and identify forward plan
9. If pressure has built or is anticipated during the kill to reach 70% or greater of the RWP of the annular preventer, confirm spacing and close the upper variable bore rams.

### General Procedure With No Pipe In Hole (Open Hole)

1. Sound alarm (alert crew)
2. Shut-in with blind rams (HCR & choke will already be in the closed position)
3. Confirm shut-in
4. Notify toolpusher/company representative
5. Read and record the following:
  - a. SICP
  - b. Pit gain
  - c. Time
6. Regroup and identify forward plan

### General Procedures While Pulling BHA Through Stack

1. PRIOR to pulling last joint of drillpipe through stack:
  - a. Perform flow check. If flowing, continue to (b).
  - b. Sound alarm (alert crew)
  - c. Stab full-opening safety valve and close
  - d. Space out drill string with tool joint just beneath the upper variable bore rams
  - e. Shut-in using upper variable bore rams (HCR & choke will already be in the closed position)
  - f. Confirm shut-in
  - g. Notify toolpusher/company representative
  - h. Read and record the following:
    - i. SIDPP & SICP
    - ii. Pit gain
    - iii. Time
  - i. Regroup and identify forward plan
2. With BHA in the stack and compatible ram preventer and pipe combination immediately available:
  - a. Sound alarm (alert crew)
  - b. Stab crossover and full-opening safety valve and close
  - c. Space out drill string with upset just beneath the upper variable bore rams
  - d. Shut-in using upper variable bore rams (HCR & choke will already be in the closed position)
  - e. Confirm shut-in
  - f. Notify toolpusher/company representative
  - g. Read and record the following:
    - i. SIDPP & SICP

- ii. Pit gain
  - iii. Time
- h. Regroup and identify forward plan
- 3. With BHA in the stack and NO compatible ram preventer and pipe combination immediately available:
  - a. Sound alarm (alert crew)
  - b. If possible, pull string clear of the stack and follow "Open Hole" procedure.
  - c. If impossible to pull string clear of the stack:
  - d. Stab crossover, make up one joint/stand of drillpipe and full-opening safety valve and close
  - e. Space out drill string with tooljoint just beneath the upper variable bore ram
  - f. Shut-in using upper variable bore ram (HCR & choke will already be in the closed position)
  - g. Confirm shut-in
  - h. Notify toolpusher/company representative
  - i. Read and record the following:
    - i. SIDPP & SICP
    - ii. Pit gain
    - iii. Time
  - j. Regroup and identify forward plan

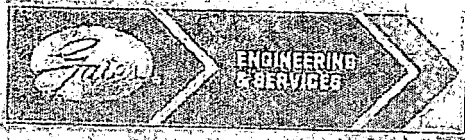

GATES E & S NORTH AMERICA, INC.  
 DU-TEX  
 134 44TH STREET  
 CORPUS CHRISTI, TEXAS 78405

PHONE: 361-887-9807  
 FAX: 361-887-0812  
 EMAIL: crpe@s@gates.com  
 WEB: www.gates.com

**GRADE D PRESSURE TEST CERTIFICATE**

Customer #	AUSTIN DISTRIBUTING	Test Date	6/8/2014
Customer Ref. #	PENDING	Hose Serial No.	D-060814-1
Invoice No.	201709	Created By	NORI-IA
Product Description	FD3.042.08 1 1/16.5K FLG/E LE		
End Fitting 1	1 1/16 in. SK FLG	End Fitting 2	1 1/16 in. SK FLG
Gates Part No.	4774-6001	Assembly Code	L3309001J513D-060814-1
Working Pressure	5,000 PSI	Test Pressure	7,500 PSI

Gates E & S North America, Inc. certifies that the following hose assembly has been tested to the Gates Oilfield Roughneck Agreement/Specification requirements and passed the 15 minute hydrostatic test per API Spec 7K/Q1, Fifth Edition, June 2010, Test pressure 9.6.7 and per Table 9 to 7,500 psi in accordance with this product number. Hose burst pressure 9.6.7.2 exceeds the minimum of 2.5 times the working pressure per Table 9.

Quality Control	QUALITY	Technical Supervisor	PRODUCTION
Signature	<i>[Signature]</i>	Date	6/8/2014
		Signature	<i>[Signature]</i>

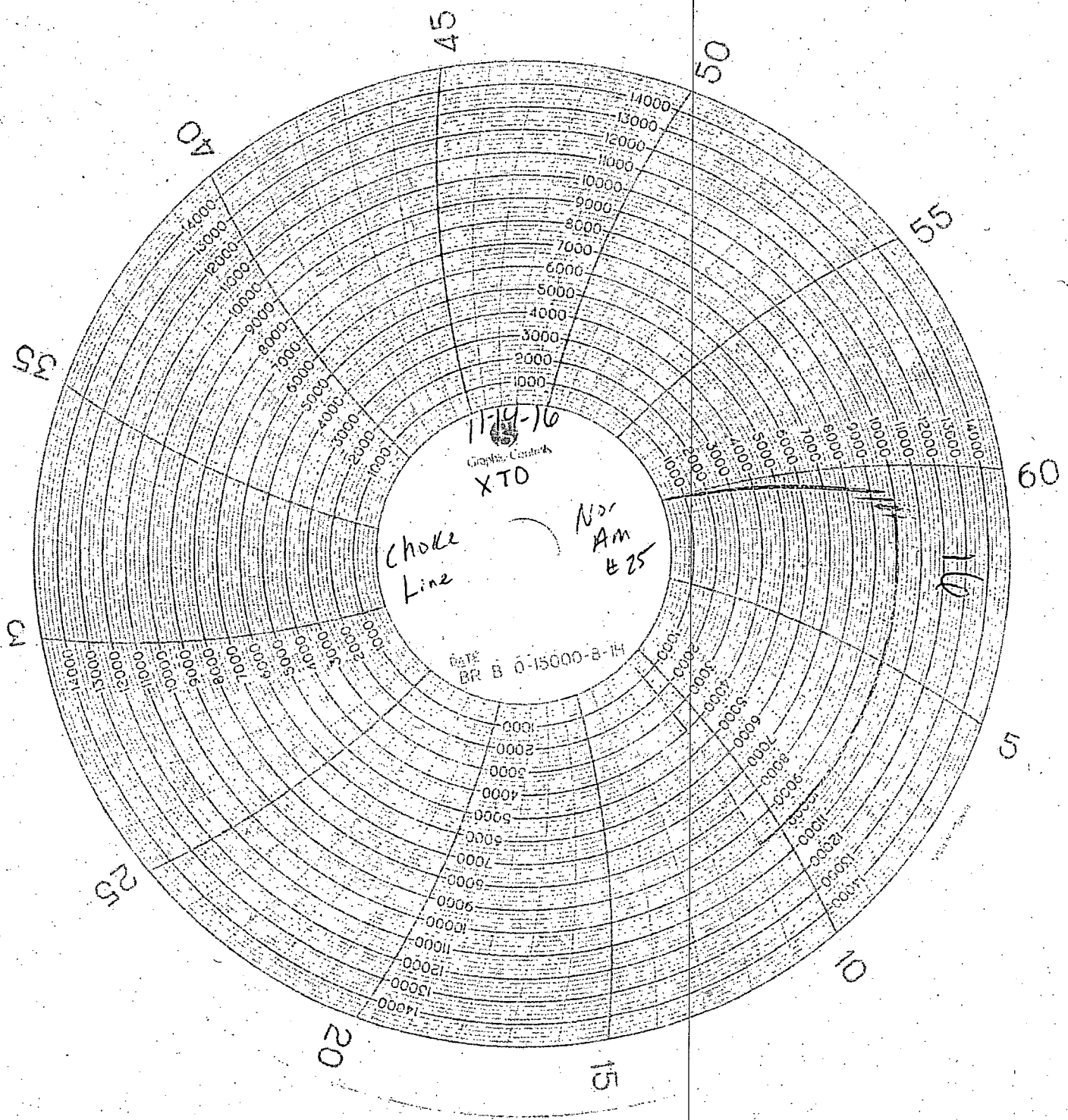

11-14-16  
Graphs, Castells  
XTO  
Nºr Am # 25  
Choke Line

DATE BR B 0-15000-8-14

CM  
CM



NOON

HOSE I.D.  $2\frac{1}{2}$ " LENGTH 42ft END 1  $4\frac{1}{16}$ " SKAFAS END 2  $4\frac{1}{16}$ " SKAFAS

GRADE  $2\frac{1}{2}$ " WORKING PRESSURE 5,000 PS.I.

TEST PRESSURE 7,500 PS.I. ASSEMBLY DATE 6-8-14

TEST DATE 6-8-14 SERIAL # L330960115137-060814-82000

NAME D. J. CR # 25613

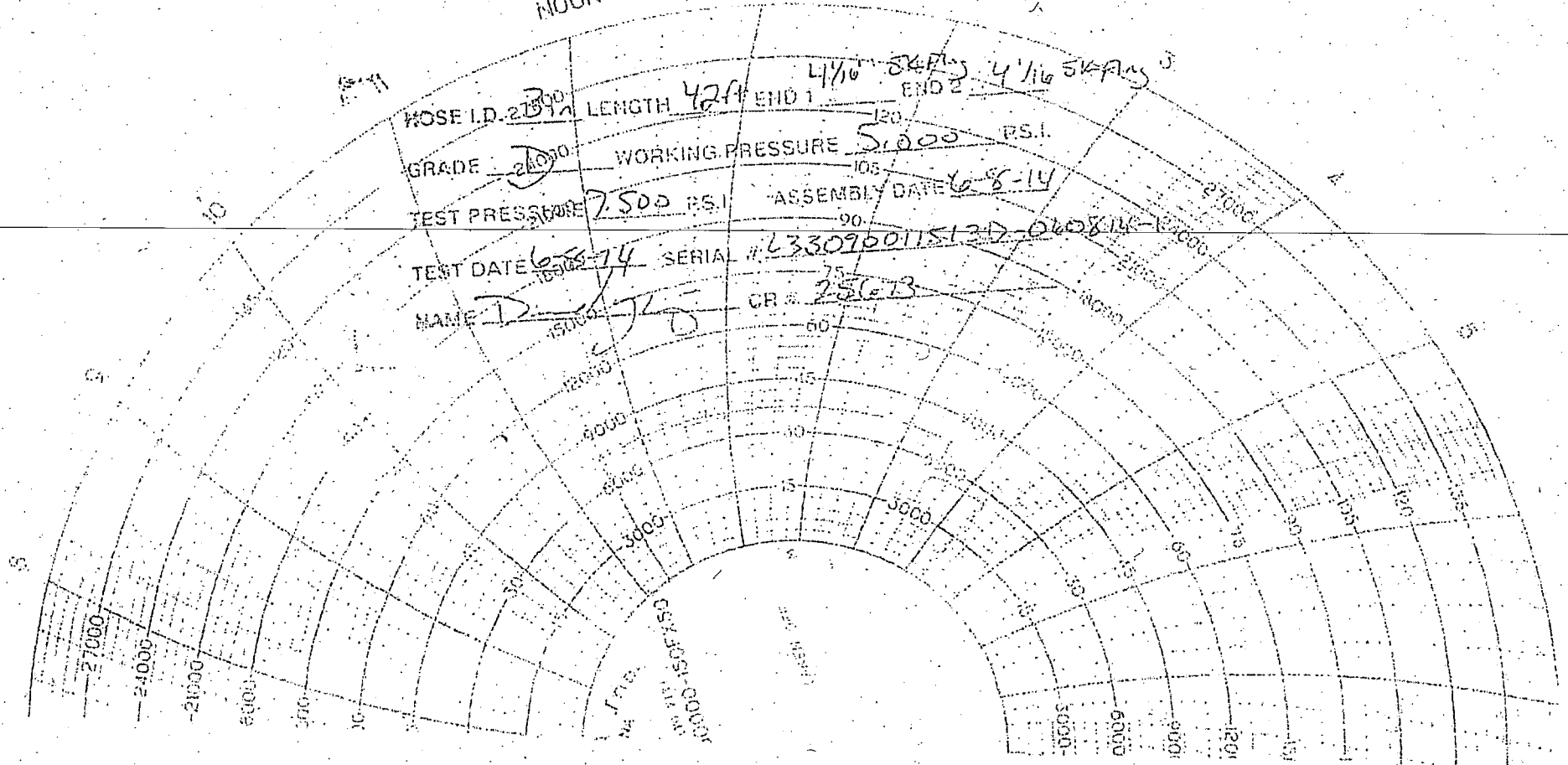

Plan Editor - 152H/152H Lateral/Plan #1

	MD (usft)	CL (usft)	Inc (°)	Azi (°)	TVD (usft)	NS (usft)	EW (usft)	V.Sec (usft)	Dogleg (°/100ft)	T.Face (°)	Build (°/100ft)	Turn (°/100ft)	Section Type	Target
1	0.00		0.00	0.00	0.00	0.00	0.00	0.00	0.00	0.00	0.00	0.00	Tie Line	
2	2500.00	2500.00	0.00	0.00	2500.00	0.00	0.00	0.00	0.00	0.00	0.00	0.00	S-Shape	
3	2766.94	266.94	4.00	75.49	2766.72	2.34	9.03	-2.32	1.50	75.49	1.50	0.00	(ditto)	
4	6810.01	4043.07	4.00	75.49	6799.92	73.06	282.34	-72.51	0.00	0.00	0.00	0.00	(ditto)	
5	7210.41	400.40	0.00	0.00	7200.00	76.56	295.88	-75.99	1.00	180.00	-1.00	0.00	(ditto)	
6	11508.4	4298.04	0.00	0.00	11498.04	76.56	295.88	-75.99	0.00	0.00	0.00	0.00	Straight TVD	
7	12408.4	900.00	90.00	179.89	12071.00	496.40	296.98	496.96	10.00	179.89	10.00	0.00	Inc Azi DLS	
8	27806.8	15398.43	90.00	179.89	12071.00	15894.80	326.54	15895.40	0.00	0.00	0.00	0.00	Straight VSEC	PLU27BD 152H PBH
9													Insert Line	

# **XTO Energy**

**Eddy County, NM (NAD27) NMEZ Grid**

**PLU 27 BD**

**152H - Slot PLU27BD 152H SHL**

**152H Lateral**

**Plan: Plan #1**

## **Standard Planning Report**

**10 December, 2019**

\\XTO\IT\GIS\Projects\152H\152H\_Slot\_PLU27BD\_152H\_SHL\152H\_Lateral\152H\_Lateral\_Summary\_Report\152H\_Lateral\_Summary\_Report.dwg



Planning Report

<b>Database:</b>	STRYKER_EDM	<b>Local Co-ordinate Reference:</b>	Well 152H - Slot PLU27BD 152H SHL
<b>Company:</b>	XTO Energy	<b>TVD Reference:</b>	3268+23 @ 3291.00usft (M7504)
<b>Project:</b>	Eddy County, NM (NAD27) NMEZ Grid	<b>MD Reference:</b>	3268+23 @ 3291.00usft (M7504)
<b>Site:</b>	PLU 27 BD	<b>North Reference:</b>	Grid
<b>Well:</b>	152H	<b>Survey Calculation Method:</b>	Minimum Curvature
<b>Wellbore:</b>	152H Lateral		
<b>Design:</b>	Plan #1		

<b>Project:</b>	Eddy County, NM (NAD27) NMEZ Grid		
<b>Map System:</b>	US State Plane 1927 (Exact solution)	<b>System Datum:</b>	Mean Sea Level
<b>Geo Datum:</b>	NAD 1927 (NADCON CONUS)		
<b>Map Zone:</b>	New Mexico East 3001		

<b>Site:</b>	PLU 27 BD				
<b>Site Position:</b>	<b>Northing:</b>	400,913.60 usft	<b>Latitude:</b>	32° 6' 5.03442199 N	
<b>From:</b>	Map	<b>Easting:</b>	641,911.20 usft	<b>Longitude:</b>	103° 52' 30.16021613 W
<b>Position Uncertainty:</b>	0.00 usft	<b>Slot Radius:</b>	13.20 in	<b>Grid Convergence:</b>	0.24 °

<b>Well:</b>	152H - Slot PLU27BD 152H SHL					
<b>Well Position</b>	<b>+N-S</b>	0.80 usft	<b>Northing:</b>	400,914.40 usft	<b>Latitude:</b>	32° 6' 5.03981449 N
	<b>+E-W</b>	60.00 usft	<b>Easting:</b>	641,971.20 usft	<b>Longitude:</b>	103° 52' 29.46264410 W
<b>Position Uncertainty</b>	0.00 usft	<b>Wellhead Elevation:</b>		<b>Ground Level:</b>	3,268.00 usft	

<b>Wellbore:</b>	152H Lateral				
------------------	--------------	--	--	--	--

Magnetics	Model Name	Sample Date	Declination (°)	Dip Angle (°)	Field Strength (nT)
	IGRF2015	12/10/19	6.82	59.87	47,580.00663977

<b>Design:</b>	Plan #1				
----------------	---------	--	--	--	--

<b>Audit Notes:</b>						
<b>Version:</b>	Phase:	PROTOTYPE			<b>Tie On Depth:</b>	0.00

Vertical Section:	Depth From (TVD) (usft)	+N-S (usft)	+E-W (usft)	Direction (°)
	0.00	0.00	0.00	179.89

<b>Plan Survey Tool Program</b>	Date	12/10/19			
---------------------------------	------	----------	--	--	--

Depth From (usft)	Depth To (usft)	Survey (Wellbore)	Tool Name	Remarks
1	0.00	27,806.88	Plan #1 (152H Lateral)	MWD+IFR1+MS OWSG MWD + IFR1 + Multi-SI

**Plan Sections**

Measured Depth (usft)	Inclination (°)	Azimuth (°)	Vertical Depth (usft)	+N-S (usft)	+E-W (usft)	Dogleg Rate (%/100ft)	Build Rate (%/100ft)	Turn Rate (%/100ft)	TFO (°)	Target
0.00	0.00	0.00	0.00	0.00	0.00	0.00	0.00	0.00	0.00	
2,500.00	0.00	0.00	2,500.00	0.00	0.00	0.00	0.00	0.00	0.00	
2,766.94	4.00	75.49	2,766.72	2.34	9.03	1.50	1.50	0.00	75.49	
6,810.01	4.00	75.49	6,799.92	73.06	282.34	0.00	0.00	0.00	0.00	
7,210.41	0.00	0.00	7,200.00	76.56	295.88	1.00	-1.00	0.00	180.00	
11,508.45	0.00	0.00	11,498.04	76.56	295.88	0.00	0.00	0.00	0.00	
12,408.45	90.00	179.89	12,071.00	-496.40	296.98	10.00	10.00	0.00	179.89	
27,806.88	90.00	179.89	12,071.00	-15,894.80	326.54	0.00	0.00	0.00	0.00	PLU27BD 152H PBHI

Planning Report

<b>Database:</b>	STRYKER.EDM	<b>Local Co-ordinate Reference:</b>	Well 152H - Slot PLU27BD 152H SHL
<b>Company:</b>	XTO Energy	<b>TVD Reference:</b>	3268+23 @ 3291.00usft (M7504)
<b>Project:</b>	Eddy County, NM (NAD27) NMEZ Grid	<b>MD Reference:</b>	3268+23 @ 3291.00usft (M7504)
<b>Site:</b>	PLU 27 BD	<b>North Reference:</b>	Grid
<b>Well:</b>	152H	<b>Survey Calculation Method:</b>	Minimum Curvature
<b>Wellbore:</b>	152H Lateral		
<b>Design:</b>	Plan #1		

Planned Survey										
Measured Depth (usft)	Inclination (°)	Azimuth (°)	Vertical Depth (usft)	+N-S (usft)	+E-W (usft)	Vertical Section (usft)	Dogleg Rate (°/100ft)	Build Rate (°/100ft)	Turn Rate (°/100ft)	
0.00	0.00	0.00	0.00	0.00	0.00	0.00	0.00	0.00	0.00	0.00
100.00	0.00	0.00	100.00	0.00	0.00	0.00	0.00	0.00	0.00	0.00
200.00	0.00	0.00	200.00	0.00	0.00	0.00	0.00	0.00	0.00	0.00
300.00	0.00	0.00	300.00	0.00	0.00	0.00	0.00	0.00	0.00	0.00
400.00	0.00	0.00	400.00	0.00	0.00	0.00	0.00	0.00	0.00	0.00
500.00	0.00	0.00	500.00	0.00	0.00	0.00	0.00	0.00	0.00	0.00
600.00	0.00	0.00	600.00	0.00	0.00	0.00	0.00	0.00	0.00	0.00
700.00	0.00	0.00	700.00	0.00	0.00	0.00	0.00	0.00	0.00	0.00
800.00	0.00	0.00	800.00	0.00	0.00	0.00	0.00	0.00	0.00	0.00
900.00	0.00	0.00	900.00	0.00	0.00	0.00	0.00	0.00	0.00	0.00
1,000.00	0.00	0.00	1,000.00	0.00	0.00	0.00	0.00	0.00	0.00	0.00
1,100.00	0.00	0.00	1,100.00	0.00	0.00	0.00	0.00	0.00	0.00	0.00
1,200.00	0.00	0.00	1,200.00	0.00	0.00	0.00	0.00	0.00	0.00	0.00
1,300.00	0.00	0.00	1,300.00	0.00	0.00	0.00	0.00	0.00	0.00	0.00
1,400.00	0.00	0.00	1,400.00	0.00	0.00	0.00	0.00	0.00	0.00	0.00
1,500.00	0.00	0.00	1,500.00	0.00	0.00	0.00	0.00	0.00	0.00	0.00
1,600.00	0.00	0.00	1,600.00	0.00	0.00	0.00	0.00	0.00	0.00	0.00
1,700.00	0.00	0.00	1,700.00	0.00	0.00	0.00	0.00	0.00	0.00	0.00
1,800.00	0.00	0.00	1,800.00	0.00	0.00	0.00	0.00	0.00	0.00	0.00
1,900.00	0.00	0.00	1,900.00	0.00	0.00	0.00	0.00	0.00	0.00	0.00
2,000.00	0.00	0.00	2,000.00	0.00	0.00	0.00	0.00	0.00	0.00	0.00
2,100.00	0.00	0.00	2,100.00	0.00	0.00	0.00	0.00	0.00	0.00	0.00
2,200.00	0.00	0.00	2,200.00	0.00	0.00	0.00	0.00	0.00	0.00	0.00
2,300.00	0.00	0.00	2,300.00	0.00	0.00	0.00	0.00	0.00	0.00	0.00
2,400.00	0.00	0.00	2,400.00	0.00	0.00	0.00	0.00	0.00	0.00	0.00
2,500.00	0.00	0.00	2,500.00	0.00	0.00	0.00	0.00	0.00	0.00	0.00
2,600.00	1.50	75.49	2,599.99	0.33	1.27	-0.33	1.50	1.50	0.00	0.00
2,700.00	3.00	75.49	2,699.91	1.31	5.07	-1.30	1.50	1.50	0.00	0.00
2,766.94	4.00	75.49	2,766.72	2.34	9.03	-2.32	1.50	1.50	0.00	0.00
2,800.00	4.00	75.49	2,799.70	2.91	11.26	-2.89	0.00	0.00	0.00	0.00
2,900.00	4.00	75.49	2,899.46	4.66	18.02	-4.63	0.00	0.00	0.00	0.00
3,000.00	4.00	75.49	2,999.21	6.41	24.78	-6.36	0.00	0.00	0.00	0.00
3,100.00	4.00	75.49	3,098.97	8.16	31.54	-8.10	0.00	0.00	0.00	0.00
3,200.00	4.00	75.49	3,198.73	9.91	38.30	-9.84	0.00	0.00	0.00	0.00
3,300.00	4.00	75.49	3,298.48	11.66	45.06	-11.57	0.00	0.00	0.00	0.00
3,400.00	4.00	75.49	3,398.24	13.41	51.82	-13.31	0.00	0.00	0.00	0.00
3,500.00	4.00	75.49	3,497.99	15.16	58.58	-15.05	0.00	0.00	0.00	0.00
3,600.00	4.00	75.49	3,597.75	16.91	65.34	-16.78	0.00	0.00	0.00	0.00
3,700.00	4.00	75.49	3,697.51	18.66	72.10	-18.52	0.00	0.00	0.00	0.00
3,800.00	4.00	75.49	3,797.26	20.41	78.86	-20.25	0.00	0.00	0.00	0.00
3,900.00	4.00	75.49	3,897.02	22.16	85.62	-21.99	0.00	0.00	0.00	0.00
4,000.00	4.00	75.49	3,996.77	23.90	92.38	-23.73	0.00	0.00	0.00	0.00
4,100.00	4.00	75.49	4,096.53	25.65	99.14	-25.46	0.00	0.00	0.00	0.00
4,200.00	4.00	75.49	4,196.28	27.40	105.90	-27.20	0.00	0.00	0.00	0.00
4,300.00	4.00	75.49	4,296.04	29.15	112.66	-28.94	0.00	0.00	0.00	0.00
4,400.00	4.00	75.49	4,395.80	30.90	119.42	-30.67	0.00	0.00	0.00	0.00
4,500.00	4.00	75.49	4,495.55	32.65	126.18	-32.41	0.00	0.00	0.00	0.00
4,600.00	4.00	75.49	4,595.31	34.40	132.94	-34.14	0.00	0.00	0.00	0.00
4,700.00	4.00	75.49	4,695.06	36.15	139.70	-35.88	0.00	0.00	0.00	0.00
4,800.00	4.00	75.49	4,794.82	37.90	146.46	-37.62	0.00	0.00	0.00	0.00
4,900.00	4.00	75.49	4,894.58	39.65	153.22	-39.35	0.00	0.00	0.00	0.00
5,000.00	4.00	75.49	4,994.33	41.40	159.98	-41.09	0.00	0.00	0.00	0.00
5,100.00	4.00	75.49	5,094.09	43.15	166.74	-42.83	0.00	0.00	0.00	0.00
5,200.00	4.00	75.49	5,193.84	44.89	173.50	-44.56	0.00	0.00	0.00	0.00

Planning Report

Database:	STRYKER_EDM	Local Co-ordinate Reference:	Well 152H - Slot PLU27BD 152H SHL
Company:	XTO Energy	TVD Reference:	3268+23 @ 3291.00usft (M7504)
Project:	Eddy County, NM (NAD27) NMEZ Grid	MD Reference:	3268+23 @ 3291.00usft (M7504)
Site:	PLU 27 BD	North Reference:	Grid
Well:	152H	Survey Calculation Method:	Minimum Curvature
Wellbore:	152H Lateral		
Design:	Plan #1		

Planned Survey										
Measured Depth (usft)	Inclination (°)	Azimuth (°)	Vertical Depth (usft)	+N/S (usft)	+E/W (usft)	Vertical Section (usft)	Dogleg Rate (°/100ft)	Build Rate (°/100ft)	Turn Rate (°/100ft)	
5,300.00	4.00	75.49	5,293.60	46.64	180.26	-46.30	0.00	0.00	0.00	
5,400.00	4.00	75.49	5,393.36	48.39	187.02	-48.03	0.00	0.00	0.00	
5,500.00	4.00	75.49	5,493.11	50.14	193.78	-49.77	0.00	0.00	0.00	
5,600.00	4.00	75.49	5,592.87	51.89	200.54	-51.51	0.00	0.00	0.00	
5,700.00	4.00	75.49	5,692.62	53.64	207.30	-53.24	0.00	0.00	0.00	
5,800.00	4.00	75.49	5,792.38	55.39	214.06	-54.98	0.00	0.00	0.00	
5,900.00	4.00	75.49	5,892.14	57.14	220.82	-56.71	0.00	0.00	0.00	
6,000.00	4.00	75.49	5,991.89	58.89	227.58	-58.45	0.00	0.00	0.00	
6,100.00	4.00	75.49	6,091.65	60.64	234.34	-60.19	0.00	0.00	0.00	
6,200.00	4.00	75.49	6,191.40	62.39	241.10	-61.92	0.00	0.00	0.00	
6,300.00	4.00	75.49	6,291.16	64.14	247.86	-63.66	0.00	0.00	0.00	
6,400.00	4.00	75.49	6,390.92	65.88	254.62	-65.40	0.00	0.00	0.00	
6,500.00	4.00	75.49	6,490.67	67.63	261.38	-67.13	0.00	0.00	0.00	
6,600.00	4.00	75.49	6,590.43	69.38	268.14	-68.87	0.00	0.00	0.00	
6,700.00	4.00	75.49	6,690.18	71.13	274.90	-70.60	0.00	0.00	0.00	
6,800.00	4.00	75.49	6,789.94	72.88	281.66	-72.34	0.00	0.00	0.00	
6,810.01	4.00	75.49	6,799.92	73.06	282.34	-72.51	0.00	0.00	0.00	
6,900.00	3.10	75.49	6,889.74	74.45	287.74	-73.90	1.00	-1.00	0.00	
7,000.00	2.10	75.49	6,989.64	75.59	292.14	-75.03	1.00	-1.00	0.00	
7,100.00	1.10	75.49	7,089.60	76.29	294.85	-75.73	1.00	-1.00	0.00	
7,200.00	0.10	75.49	7,189.59	76.56	295.87	-75.99	1.00	-1.00	0.00	
7,210.41	0.00	0.00	7,200.00	76.56	295.88	-75.99	1.00	-1.00	0.00	
7,300.00	0.00	0.00	7,289.59	76.56	295.88	-75.99	0.00	0.00	0.00	
7,400.00	0.00	0.00	7,389.59	76.56	295.88	-75.99	0.00	0.00	0.00	
7,500.00	0.00	0.00	7,489.59	76.56	295.88	-75.99	0.00	0.00	0.00	
7,600.00	0.00	0.00	7,589.59	76.56	295.88	-75.99	0.00	0.00	0.00	
7,700.00	0.00	0.00	7,689.59	76.56	295.88	-75.99	0.00	0.00	0.00	
7,800.00	0.00	0.00	7,789.59	76.56	295.88	-75.99	0.00	0.00	0.00	
7,900.00	0.00	0.00	7,889.59	76.56	295.88	-75.99	0.00	0.00	0.00	
8,000.00	0.00	0.00	7,989.59	76.56	295.88	-75.99	0.00	0.00	0.00	
8,100.00	0.00	0.00	8,089.59	76.56	295.88	-75.99	0.00	0.00	0.00	
8,200.00	0.00	0.00	8,189.59	76.56	295.88	-75.99	0.00	0.00	0.00	
8,300.00	0.00	0.00	8,289.59	76.56	295.88	-75.99	0.00	0.00	0.00	
8,400.00	0.00	0.00	8,389.59	76.56	295.88	-75.99	0.00	0.00	0.00	
8,500.00	0.00	0.00	8,489.59	76.56	295.88	-75.99	0.00	0.00	0.00	
8,600.00	0.00	0.00	8,589.59	76.56	295.88	-75.99	0.00	0.00	0.00	
8,700.00	0.00	0.00	8,689.59	76.56	295.88	-75.99	0.00	0.00	0.00	
8,800.00	0.00	0.00	8,789.59	76.56	295.88	-75.99	0.00	0.00	0.00	
8,900.00	0.00	0.00	8,889.59	76.56	295.88	-75.99	0.00	0.00	0.00	
9,000.00	0.00	0.00	8,989.59	76.56	295.88	-75.99	0.00	0.00	0.00	
9,100.00	0.00	0.00	9,089.59	76.56	295.88	-75.99	0.00	0.00	0.00	
9,200.00	0.00	0.00	9,189.59	76.56	295.88	-75.99	0.00	0.00	0.00	
9,300.00	0.00	0.00	9,289.59	76.56	295.88	-75.99	0.00	0.00	0.00	
9,400.00	0.00	0.00	9,389.59	76.56	295.88	-75.99	0.00	0.00	0.00	
9,500.00	0.00	0.00	9,489.59	76.56	295.88	-75.99	0.00	0.00	0.00	
9,600.00	0.00	0.00	9,589.59	76.56	295.88	-75.99	0.00	0.00	0.00	
9,700.00	0.00	0.00	9,689.59	76.56	295.88	-75.99	0.00	0.00	0.00	
9,800.00	0.00	0.00	9,789.59	76.56	295.88	-75.99	0.00	0.00	0.00	
9,900.00	0.00	0.00	9,889.59	76.56	295.88	-75.99	0.00	0.00	0.00	
10,000.00	0.00	0.00	9,989.59	76.56	295.88	-75.99	0.00	0.00	0.00	
10,100.00	0.00	0.00	10,089.59	76.56	295.88	-75.99	0.00	0.00	0.00	
10,200.00	0.00	0.00	10,189.59	76.56	295.88	-75.99	0.00	0.00	0.00	
10,300.00	0.00	0.00	10,289.59	76.56	295.88	-75.99	0.00	0.00	0.00	
10,400.00	0.00	0.00	10,389.59	76.56	295.88	-75.99	0.00	0.00	0.00	

Planning Report

<b>Database:</b>	STRYKER_EDM	<b>Local Co-ordinate Reference:</b>	Well 152H - Slot PLU27BD 152H SHL
<b>Company:</b>	XTO Energy	<b>TVD Reference:</b>	3268+23 @ 3291.00usft (M7504)
<b>Project:</b>	Eddy County, NM (NAD27) NMEZ Grid	<b>MD Reference:</b>	3268+23 @ 3291.00usft (M7504)
<b>Site:</b>	PLU 27 BD	<b>North Reference:</b>	Grid
<b>Well:</b>	152H	<b>Survey Calculation Method:</b>	Minimum Curvature
<b>Wellbore:</b>	152H Lateral		
<b>Design:</b>	Plan #1		

Planned Survey										
Measured Depth (usft)	Inclination (°)	Azimuth (°)	Vertical Depth (usft)	+N/S (usft)	+E/W (usft)	Vertical Section (usft)	Dogleg Rate (°/100ft)	Build Rate (°/100ft)	Turn Rate (°/100ft)	
10,500.00	0.00	0.00	10,489.59	76.56	295.88	-75.99	0.00	0.00	0.00	0.00
10,600.00	0.00	0.00	10,589.59	76.56	295.88	-75.99	0.00	0.00	0.00	0.00
10,700.00	0.00	0.00	10,689.59	76.56	295.88	-75.99	0.00	0.00	0.00	0.00
10,800.00	0.00	0.00	10,789.59	76.56	295.88	-75.99	0.00	0.00	0.00	0.00
10,900.00	0.00	0.00	10,889.59	76.56	295.88	-75.99	0.00	0.00	0.00	0.00
11,000.00	0.00	0.00	10,989.59	76.56	295.88	-75.99	0.00	0.00	0.00	0.00
11,100.00	0.00	0.00	11,089.59	76.56	295.88	-75.99	0.00	0.00	0.00	0.00
11,200.00	0.00	0.00	11,189.59	76.56	295.88	-75.99	0.00	0.00	0.00	0.00
11,300.00	0.00	0.00	11,289.59	76.56	295.88	-75.99	0.00	0.00	0.00	0.00
11,400.00	0.00	0.00	11,389.59	76.56	295.88	-75.99	0.00	0.00	0.00	0.00
11,508.45	0.00	0.00	11,498.04	76.56	295.88	-75.99	0.00	0.00	0.00	0.00
11,550.00	4.15	179.89	11,539.55	75.05	295.88	-74.49	10.00	10.00	0.00	0.00
11,600.00	9.15	179.89	11,589.20	69.26	295.89	-68.69	10.00	10.00	0.00	0.00
11,650.00	14.15	179.89	11,638.15	59.16	295.91	-58.60	10.00	10.00	0.00	0.00
11,700.00	19.15	179.89	11,686.04	44.84	295.94	-44.27	10.00	10.00	0.00	0.00
11,750.00	24.15	179.89	11,732.50	26.39	295.98	-25.83	10.00	10.00	0.00	0.00
11,800.00	29.15	179.89	11,777.17	3.97	296.02	-3.40	10.00	10.00	0.00	0.00
11,850.00	34.15	179.89	11,819.72	-22.26	296.07	22.83	10.00	10.00	0.00	0.00
11,900.00	39.15	179.89	11,859.82	-52.10	296.13	52.67	10.00	10.00	0.00	0.00
11,950.00	44.15	179.89	11,897.16	-85.32	296.19	85.89	10.00	10.00	0.00	0.00
12,000.00	49.15	179.89	11,931.47	-121.67	296.26	122.24	10.00	10.00	0.00	0.00
12,050.00	54.15	179.89	11,962.48	-160.88	296.34	161.44	10.00	10.00	0.00	0.00
12,100.00	59.15	179.89	11,989.96	-202.63	296.42	203.20	10.00	10.00	0.00	0.00
12,150.00	64.15	179.89	12,013.69	-246.62	296.50	247.19	10.00	10.00	0.00	0.00
12,200.00	69.15	179.89	12,033.49	-292.51	296.59	293.08	10.00	10.00	0.00	0.00
12,250.00	74.15	179.89	12,049.23	-339.96	296.68	340.53	10.00	10.00	0.00	0.00
12,300.00	79.15	179.89	12,060.76	-388.59	296.77	389.16	10.00	10.00	0.00	0.00
12,350.00	84.15	179.89	12,068.02	-438.05	296.87	438.62	10.00	10.00	0.00	0.00
12,400.00	89.16	179.89	12,070.93	-487.95	296.96	488.52	10.00	10.00	0.00	0.00
12,408.45	90.00	179.89	12,071.00	-496.40	296.98	496.96	10.00	10.00	0.00	0.00
12,500.00	90.00	179.89	12,071.00	-587.95	297.16	588.51	0.00	0.00	0.00	0.00
12,600.00	90.00	179.89	12,071.00	-687.95	297.35	688.51	0.00	0.00	0.00	0.00
12,700.00	90.00	179.89	12,071.00	-787.95	297.54	788.51	0.00	0.00	0.00	0.00
12,800.00	90.00	179.89	12,071.00	-887.94	297.73	888.51	0.00	0.00	0.00	0.00
12,900.00	90.00	179.89	12,071.00	-987.94	297.92	988.51	0.00	0.00	0.00	0.00
13,000.00	90.00	179.89	12,071.00	-1,087.94	298.12	1,088.51	0.00	0.00	0.00	0.00
13,100.00	90.00	179.89	12,071.00	-1,187.94	298.31	1,188.51	0.00	0.00	0.00	0.00
13,200.00	90.00	179.89	12,071.00	-1,287.94	298.50	1,288.51	0.00	0.00	0.00	0.00
13,300.00	90.00	179.89	12,071.00	-1,387.94	298.69	1,388.51	0.00	0.00	0.00	0.00
13,400.00	90.00	179.89	12,071.00	-1,487.94	298.88	1,488.51	0.00	0.00	0.00	0.00
13,500.00	90.00	179.89	12,071.00	-1,587.94	299.08	1,588.51	0.00	0.00	0.00	0.00
13,600.00	90.00	179.89	12,071.00	-1,687.94	299.27	1,688.51	0.00	0.00	0.00	0.00
13,700.00	90.00	179.89	12,071.00	-1,787.94	299.46	1,788.51	0.00	0.00	0.00	0.00
13,800.00	90.00	179.89	12,071.00	-1,887.94	299.65	1,888.51	0.00	0.00	0.00	0.00
13,900.00	90.00	179.89	12,071.00	-1,987.94	299.84	1,988.51	0.00	0.00	0.00	0.00
14,000.00	90.00	179.89	12,071.00	-2,087.94	300.04	2,088.51	0.00	0.00	0.00	0.00
14,100.00	90.00	179.89	12,071.00	-2,187.94	300.23	2,188.51	0.00	0.00	0.00	0.00
14,200.00	90.00	179.89	12,071.00	-2,287.94	300.42	2,288.51	0.00	0.00	0.00	0.00
14,300.00	90.00	179.89	12,071.00	-2,387.94	300.61	2,388.51	0.00	0.00	0.00	0.00
14,400.00	90.00	179.89	12,071.00	-2,487.94	300.80	2,488.51	0.00	0.00	0.00	0.00
14,500.00	90.00	179.89	12,071.00	-2,587.94	301.00	2,588.51	0.00	0.00	0.00	0.00
14,600.00	90.00	179.89	12,071.00	-2,687.94	301.19	2,688.51	0.00	0.00	0.00	0.00
14,700.00	90.00	179.89	12,071.00	-2,787.94	301.38	2,788.51	0.00	0.00	0.00	0.00
14,800.00	90.00	179.89	12,071.00	-2,887.94	301.57	2,888.51	0.00	0.00	0.00	0.00

Planning Report

<b>Database:</b>	STRYKER_EDM	<b>Local Co-ordinate Reference:</b>	Well 152H - Slot PLU27BD 152H SHL
<b>Company:</b>	XTO Energy	<b>TVD Reference:</b>	3268+23 @ 3291.00usft (M7504)
<b>Project:</b>	Eddy County, NM (NAD27) NMEZ Grid	<b>MD Reference:</b>	3268+23 @ 3291.00usft (M7504)
<b>Site:</b>	PLU 27 BD	<b>North Reference:</b>	Grid
<b>Well:</b>	152H	<b>Survey Calculation Method:</b>	Minimum Curvature
<b>Wellbore:</b>	152H Lateral		
<b>Design:</b>	Plan #1		

Planned Survey										
Measured Depth (usft)	Inclination (°)	Azimuth (°)	Vertical Depth (usft)	+N/S (usft)	+E/W (usft)	Vertical Section (usft)	Dogleg Rate (°/100ft)	Build Rate (°/100ft)	Turn Rate (°/100ft)	
14,900.00	90.00	179.89	12,071.00	-2,987.94	301.76	2,988.51	0.00	0.00	0.00	
15,000.00	90.00	179.89	12,071.00	-3,087.94	301.96	3,088.51	0.00	0.00	0.00	
15,100.00	90.00	179.89	12,071.00	-3,187.94	302.15	3,188.51	0.00	0.00	0.00	
15,200.00	90.00	179.89	12,071.00	-3,287.94	302.34	3,288.51	0.00	0.00	0.00	
15,300.00	90.00	179.89	12,071.00	-3,387.94	302.53	3,388.51	0.00	0.00	0.00	
15,400.00	90.00	179.89	12,071.00	-3,487.94	302.72	3,488.51	0.00	0.00	0.00	
15,500.00	90.00	179.89	12,071.00	-3,587.94	302.92	3,588.51	0.00	0.00	0.00	
15,600.00	90.00	179.89	12,071.00	-3,687.94	303.11	3,688.51	0.00	0.00	0.00	
15,700.00	90.00	179.89	12,071.00	-3,787.94	303.30	3,788.51	0.00	0.00	0.00	
15,800.00	90.00	179.89	12,071.00	-3,887.94	303.49	3,888.51	0.00	0.00	0.00	
15,900.00	90.00	179.89	12,071.00	-3,987.94	303.68	3,988.51	0.00	0.00	0.00	
16,000.00	90.00	179.89	12,071.00	-4,087.94	303.88	4,088.51	0.00	0.00	0.00	
16,100.00	90.00	179.89	12,071.00	-4,187.94	304.07	4,188.51	0.00	0.00	0.00	
16,200.00	90.00	179.89	12,071.00	-4,287.94	304.26	4,288.51	0.00	0.00	0.00	
16,300.00	90.00	179.89	12,071.00	-4,387.94	304.45	4,388.51	0.00	0.00	0.00	
16,400.00	90.00	179.89	12,071.00	-4,487.94	304.64	4,488.51	0.00	0.00	0.00	
16,500.00	90.00	179.89	12,071.00	-4,587.94	304.84	4,588.51	0.00	0.00	0.00	
16,600.00	90.00	179.89	12,071.00	-4,687.94	305.03	4,688.51	0.00	0.00	0.00	
16,700.00	90.00	179.89	12,071.00	-4,787.94	305.22	4,788.51	0.00	0.00	0.00	
16,800.00	90.00	179.89	12,071.00	-4,887.94	305.41	4,888.51	0.00	0.00	0.00	
16,900.00	90.00	179.89	12,071.00	-4,987.94	305.60	4,988.51	0.00	0.00	0.00	
17,000.00	90.00	179.89	12,071.00	-5,087.94	305.80	5,088.52	0.00	0.00	0.00	
17,100.00	90.00	179.89	12,071.00	-5,187.94	305.99	5,188.52	0.00	0.00	0.00	
17,200.00	90.00	179.89	12,071.00	-5,287.94	306.18	5,288.52	0.00	0.00	0.00	
17,300.00	90.00	179.89	12,071.00	-5,387.94	306.37	5,388.52	0.00	0.00	0.00	
17,400.00	90.00	179.89	12,071.00	-5,487.94	306.56	5,488.52	0.00	0.00	0.00	
17,500.00	90.00	179.89	12,071.00	-5,587.94	306.76	5,588.52	0.00	0.00	0.00	
17,600.00	90.00	179.89	12,071.00	-5,687.94	306.95	5,688.52	0.00	0.00	0.00	
17,700.00	90.00	179.89	12,071.00	-5,787.94	307.14	5,788.52	0.00	0.00	0.00	
17,800.00	90.00	179.89	12,071.00	-5,887.94	307.33	5,888.52	0.00	0.00	0.00	
17,900.00	90.00	179.89	12,071.00	-5,987.94	307.52	5,988.52	0.00	0.00	0.00	
18,000.00	90.00	179.89	12,071.00	-6,087.94	307.72	6,088.52	0.00	0.00	0.00	
18,100.00	90.00	179.89	12,071.00	-6,187.94	307.91	6,188.52	0.00	0.00	0.00	
18,200.00	90.00	179.89	12,071.00	-6,287.94	308.10	6,288.52	0.00	0.00	0.00	
18,300.00	90.00	179.89	12,071.00	-6,387.93	308.29	6,388.52	0.00	0.00	0.00	
18,400.00	90.00	179.89	12,071.00	-6,487.93	308.48	6,488.52	0.00	0.00	0.00	
18,500.00	90.00	179.89	12,071.00	-6,587.93	308.67	6,588.52	0.00	0.00	0.00	
18,600.00	90.00	179.89	12,071.00	-6,687.93	308.87	6,688.52	0.00	0.00	0.00	
18,700.00	90.00	179.89	12,071.00	-6,787.93	309.06	6,788.52	0.00	0.00	0.00	
18,800.00	90.00	179.89	12,071.00	-6,887.93	309.25	6,888.52	0.00	0.00	0.00	
18,900.00	90.00	179.89	12,071.00	-6,987.93	309.44	6,988.52	0.00	0.00	0.00	
19,000.00	90.00	179.89	12,071.00	-7,087.93	309.63	7,088.52	0.00	0.00	0.00	
19,100.00	90.00	179.89	12,071.00	-7,187.93	309.83	7,188.52	0.00	0.00	0.00	
19,200.00	90.00	179.89	12,071.00	-7,287.93	310.02	7,288.52	0.00	0.00	0.00	
19,300.00	90.00	179.89	12,071.00	-7,387.93	310.21	7,388.52	0.00	0.00	0.00	
19,400.00	90.00	179.89	12,071.00	-7,487.93	310.40	7,488.52	0.00	0.00	0.00	
19,500.00	90.00	179.89	12,071.00	-7,587.93	310.59	7,588.52	0.00	0.00	0.00	
19,600.00	90.00	179.89	12,071.00	-7,687.93	310.79	7,688.52	0.00	0.00	0.00	
19,700.00	90.00	179.89	12,071.00	-7,787.93	310.98	7,788.52	0.00	0.00	0.00	
19,800.00	90.00	179.89	12,071.00	-7,887.93	311.17	7,888.52	0.00	0.00	0.00	
19,900.00	90.00	179.89	12,071.00	-7,987.93	311.36	7,988.52	0.00	0.00	0.00	
20,000.00	90.00	179.89	12,071.00	-8,087.93	311.55	8,088.52	0.00	0.00	0.00	
20,100.00	90.00	179.89	12,071.00	-8,187.93	311.75	8,188.52	0.00	0.00	0.00	
20,200.00	90.00	179.89	12,071.00	-8,287.93	311.94	8,288.52	0.00	0.00	0.00	



Planning Report

<b>Database:</b>	STRYKER_EDM	<b>Local Co-ordinate Reference:</b>	Well 152H - Slot PLU27BD 152H.SHL
<b>Company:</b>	XTO Energy	<b>TVD Reference:</b>	3268+23 @ 3291.00usft (M7504)
<b>Project:</b>	Eddy County, NM (NAD27) NMEZ Grid	<b>MD Reference:</b>	3268+23 @ 3291.00usft (M7504)
<b>Site:</b>	PLU 27 BD	<b>North Reference:</b>	Grid
<b>Well:</b>	152H	<b>Survey Calculation Method:</b>	Minimum Curvature
<b>Wellbore:</b>	152H Lateral		
<b>Design:</b>	Plan #1		

Planned Survey										
Measured Depth (usft)	Inclination (°)	Azimuth (°)	Vertical Depth (usft)	+N/S (usft)	+E/W (usft)	Vertical Section (usft)	Dogleg Rate (°/100ft)	Build Rate (°/100ft)	Turn Rate (°/100ft)	
20,300.00	90.00	179.89	12,071.00	-8,387.93	312.13	8,388.52	0.00	0.00	0.00	
20,400.00	90.00	179.89	12,071.00	-8,487.93	312.32	8,488.52	0.00	0.00	0.00	
20,500.00	90.00	179.89	12,071.00	-8,587.93	312.51	8,588.52	0.00	0.00	0.00	
20,600.00	90.00	179.89	12,071.00	-8,687.93	312.71	8,688.52	0.00	0.00	0.00	
20,700.00	90.00	179.89	12,071.00	-8,787.93	312.90	8,788.52	0.00	0.00	0.00	
20,800.00	90.00	179.89	12,071.00	-8,887.93	313.09	8,888.52	0.00	0.00	0.00	
20,900.00	90.00	179.89	12,071.00	-8,987.93	313.28	8,988.52	0.00	0.00	0.00	
21,000.00	90.00	179.89	12,071.00	-9,087.93	313.47	9,088.52	0.00	0.00	0.00	
21,100.00	90.00	179.89	12,071.00	-9,187.93	313.67	9,188.52	0.00	0.00	0.00	
21,200.00	90.00	179.89	12,071.00	-9,287.93	313.86	9,288.52	0.00	0.00	0.00	
21,300.00	90.00	179.89	12,071.00	-9,387.93	314.05	9,388.52	0.00	0.00	0.00	
21,400.00	90.00	179.89	12,071.00	-9,487.93	314.24	9,488.52	0.00	0.00	0.00	
21,500.00	90.00	179.89	12,071.00	-9,587.93	314.43	9,588.52	0.00	0.00	0.00	
21,600.00	90.00	179.89	12,071.00	-9,687.93	314.63	9,688.52	0.00	0.00	0.00	
21,700.00	90.00	179.89	12,071.00	-9,787.93	314.82	9,788.52	0.00	0.00	0.00	
21,800.00	90.00	179.89	12,071.00	-9,887.93	315.01	9,888.52	0.00	0.00	0.00	
21,900.00	90.00	179.89	12,071.00	-9,987.93	315.20	9,988.52	0.00	0.00	0.00	
22,000.00	90.00	179.89	12,071.00	-10,087.93	315.39	10,088.52	0.00	0.00	0.00	
22,100.00	90.00	179.89	12,071.00	-10,187.93	315.59	10,188.52	0.00	0.00	0.00	
22,200.00	90.00	179.89	12,071.00	-10,287.93	315.78	10,288.52	0.00	0.00	0.00	
22,300.00	90.00	179.89	12,071.00	-10,387.93	315.97	10,388.52	0.00	0.00	0.00	
22,400.00	90.00	179.89	12,071.00	-10,487.93	316.16	10,488.52	0.00	0.00	0.00	
22,500.00	90.00	179.89	12,071.00	-10,587.93	316.35	10,588.52	0.00	0.00	0.00	
22,600.00	90.00	179.89	12,071.00	-10,687.93	316.55	10,688.52	0.00	0.00	0.00	
22,700.00	90.00	179.89	12,071.00	-10,787.93	316.74	10,788.52	0.00	0.00	0.00	
22,800.00	90.00	179.89	12,071.00	-10,887.93	316.93	10,888.52	0.00	0.00	0.00	
22,900.00	90.00	179.89	12,071.00	-10,987.93	317.12	10,988.52	0.00	0.00	0.00	
23,000.00	90.00	179.89	12,071.00	-11,087.93	317.31	11,088.52	0.00	0.00	0.00	
23,100.00	90.00	179.89	12,071.00	-11,187.93	317.51	11,188.52	0.00	0.00	0.00	
23,200.00	90.00	179.89	12,071.00	-11,287.93	317.70	11,288.52	0.00	0.00	0.00	
23,300.00	90.00	179.89	12,071.00	-11,387.93	317.89	11,388.52	0.00	0.00	0.00	
23,400.00	90.00	179.89	12,071.00	-11,487.93	318.08	11,488.52	0.00	0.00	0.00	
23,500.00	90.00	179.89	12,071.00	-11,587.93	318.27	11,588.52	0.00	0.00	0.00	
23,600.00	90.00	179.89	12,071.00	-11,687.93	318.47	11,688.52	0.00	0.00	0.00	
23,700.00	90.00	179.89	12,071.00	-11,787.93	318.66	11,788.52	0.00	0.00	0.00	
23,800.00	90.00	179.89	12,071.00	-11,887.92	318.85	11,888.52	0.00	0.00	0.00	
23,900.00	90.00	179.89	12,071.00	-11,987.92	319.04	11,988.52	0.00	0.00	0.00	
24,000.00	90.00	179.89	12,071.00	-12,087.92	319.23	12,088.52	0.00	0.00	0.00	
24,100.00	90.00	179.89	12,071.00	-12,187.92	319.43	12,188.52	0.00	0.00	0.00	
24,200.00	90.00	179.89	12,071.00	-12,287.92	319.62	12,288.52	0.00	0.00	0.00	
24,300.00	90.00	179.89	12,071.00	-12,387.92	319.81	12,388.52	0.00	0.00	0.00	
24,400.00	90.00	179.89	12,071.00	-12,487.92	320.00	12,488.52	0.00	0.00	0.00	
24,500.00	90.00	179.89	12,071.00	-12,587.92	320.19	12,588.52	0.00	0.00	0.00	
24,600.00	90.00	179.89	12,071.00	-12,687.92	320.39	12,688.52	0.00	0.00	0.00	
24,700.00	90.00	179.89	12,071.00	-12,787.92	320.58	12,788.52	0.00	0.00	0.00	
24,800.00	90.00	179.89	12,071.00	-12,887.92	320.77	12,888.52	0.00	0.00	0.00	
24,900.00	90.00	179.89	12,071.00	-12,987.92	320.96	12,988.52	0.00	0.00	0.00	
25,000.00	90.00	179.89	12,071.00	-13,087.92	321.15	13,088.52	0.00	0.00	0.00	
25,100.00	90.00	179.89	12,071.00	-13,187.92	321.35	13,188.52	0.00	0.00	0.00	
25,200.00	90.00	179.89	12,071.00	-13,287.92	321.54	13,288.52	0.00	0.00	0.00	
25,300.00	90.00	179.89	12,071.00	-13,387.92	321.73	13,388.52	0.00	0.00	0.00	
25,400.00	90.00	179.89	12,071.00	-13,487.92	321.92	13,488.52	0.00	0.00	0.00	
25,500.00	90.00	179.89	12,071.00	-13,587.92	322.11	13,588.52	0.00	0.00	0.00	
25,600.00	90.00	179.89	12,071.00	-13,687.92	322.31	13,688.52	0.00	0.00	0.00	

Planning Report

<b>Database:</b>	STRYKER_EDM	<b>Local Co-ordinate Reference:</b>	Well 152H - Slot PLU27BD 152H SHL
<b>Company:</b>	XTO Energy	<b>TVD Reference:</b>	3268+23 @ 3291.00usft (M7504)
<b>Project:</b>	Eddy County, NM (NAD27) NMEZ Grid	<b>MD Reference:</b>	3268+23 @ 3291.00usft (M7504)
<b>Site:</b>	PLU 27 BD	<b>North Reference:</b>	Grid
<b>Well:</b>	152H	<b>Survey Calculation Method:</b>	Minimum Curvature
<b>Wellbore:</b>	152H Lateral		
<b>Design:</b>	Plan #1		

Planned Survey										
Measured Depth (usft)	Inclination (°)	Azimuth (°)	Vertical Depth (usft)	+N/S (usft)	+E/W (usft)	Vertical Section (usft)	Dogleg Rate (°/100ft)	Build Rate (°/100ft)	Turn Rate (°/100ft)	
25,700.00	90.00	179.89	12,071.00	-13,787.92	322.50	13,788.52	0.00	0.00	0.00	
25,800.00	90.00	179.89	12,071.00	-13,887.92	322.69	13,888.52	0.00	0.00	0.00	
25,900.00	90.00	179.89	12,071.00	-13,987.92	322.88	13,988.52	0.00	0.00	0.00	
26,000.00	90.00	179.89	12,071.00	-14,087.92	323.07	14,088.52	0.00	0.00	0.00	
26,100.00	90.00	179.89	12,071.00	-14,187.92	323.27	14,188.52	0.00	0.00	0.00	
26,200.00	90.00	179.89	12,071.00	-14,287.92	323.46	14,288.52	0.00	0.00	0.00	
26,300.00	90.00	179.89	12,071.00	-14,387.92	323.65	14,388.52	0.00	0.00	0.00	
26,400.00	90.00	179.89	12,071.00	-14,487.92	323.84	14,488.52	0.00	0.00	0.00	
26,500.00	90.00	179.89	12,071.00	-14,587.92	324.03	14,588.52	0.00	0.00	0.00	
26,600.00	90.00	179.89	12,071.00	-14,687.92	324.23	14,688.52	0.00	0.00	0.00	
26,700.00	90.00	179.89	12,071.00	-14,787.92	324.42	14,788.52	0.00	0.00	0.00	
26,800.00	90.00	179.89	12,071.00	-14,887.92	324.61	14,888.52	0.00	0.00	0.00	
26,900.00	90.00	179.89	12,071.00	-14,987.92	324.80	14,988.52	0.00	0.00	0.00	
27,000.00	90.00	179.89	12,071.00	-15,087.92	324.99	15,088.52	0.00	0.00	0.00	
27,100.00	90.00	179.89	12,071.00	-15,187.92	325.19	15,188.52	0.00	0.00	0.00	
27,200.00	90.00	179.89	12,071.00	-15,287.92	325.38	15,288.52	0.00	0.00	0.00	
27,300.00	90.00	179.89	12,071.00	-15,387.92	325.57	15,388.52	0.00	0.00	0.00	
27,400.00	90.00	179.89	12,071.00	-15,487.92	325.76	15,488.52	0.00	0.00	0.00	
27,500.00	90.00	179.89	12,071.00	-15,587.92	325.95	15,588.52	0.00	0.00	0.00	
27,600.00	90.00	179.89	12,071.00	-15,687.92	326.15	15,688.52	0.00	0.00	0.00	
27,700.00	90.00	179.89	12,071.00	-15,787.92	326.34	15,788.52	0.00	0.00	0.00	
27,806.88	90.00	179.89	12,071.00	-15,894.80	326.54	15,895.40	0.00	0.00	0.00	

Design Targets										
Target Name	hit/miss target	Dip Angle (°)	Dip Dir (°)	TVD (usft)	+N/S (usft)	+E/W (usft)	Northing (usft)	Easting (usft)	Latitude	Longitude
PLU27BD 152H SHL	- plan hits target center	0.00	0.00	0.00	0.00	0.00	400,914.40	641,971.20	32° 6' 5.03981449 N	3° 52' 29.46264410 W
	- Point									
PLU27BD KOPB	- plan misses target center by 305.62usft at 0.00usft MD (0.00 TVD, 0.00 N, 0.00 E)	0.00	0.00	0.00	76.56	295.88	400,990.96	642,267.08	32° 6' 5.78499648 N	3° 52' 26.01913756 W
	- Point									
PLU27BD 152H PBHL_	- plan misses target center by 0.46usft at 27806.88usft MD (12071.00 TVD, -15894.80 N, 326.54 E)	0.00	0.00	12,071.00	-15,894.80	327.00	385,019.60	642,298.20	32° 3' 27.72644181 N	3° 52' 26.44785469 W
	- Point									
PLU27BD 152H FTP_35	- plan misses target center by 0.01usft at 12412.45usft MD (12071.00 TVD, -500.40 N, 296.99 E)	0.00	0.00	12,071.00	-500.40	297.00	400,414.00	642,268.20	32° 6' 0.07521426 N	3° 52' 26.03464825 W
	- Point									
PLU27BD 152H LTP_34	- plan misses target center by 0.19usft at 27676.88usft MD (12071.00 TVD, -15764.80 N, 326.29 E)	0.00	0.00	12,071.00	-15,764.80	326.10	385,149.60	642,297.30	32° 3' 29.01300225 N	3° 52' 26.45188491 W
	- Point									

# **XTO Energy**

**Eddy County, NM (NAD27) NMEZ Grid**

**PLU 27 BD**

**152H**

**152H Lateral**

**Plan #1**

## **Anticollision Report**

**10 December, 2019**

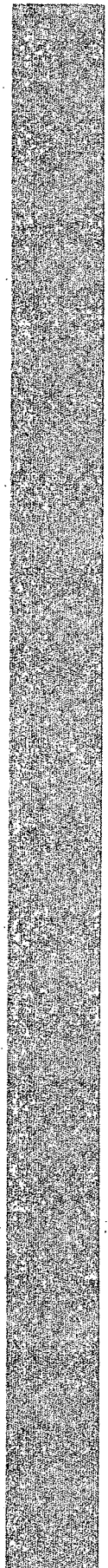

# PECOS DISTRICT DRILLING CONDITIONS OF APPROVAL

<b>OPERATOR'S NAME:</b>	<b>XTO Permian Operating, LLC</b>
<b>LEASE NO.:</b>	<b>NMLC-0063875A</b>
<b>WELL NAME &amp; NO.:</b>	<b>Poker Lake Unit 27 BD 152H</b>
<b>SURFACE HOLE FOOTAGE:</b>	<b>2510' FNL &amp; 0693' FWL</b>
<b>BOTTOM HOLE FOOTAGE:</b>	<b>2440' FNL &amp; 0990' FWL Sec. 10, T. 26 S., R 30 E.</b>
<b>LOCATION:</b>	<b>Section 27, T. 25 S., R 30 E., NMPM</b>
<b>COUNTY:</b>	<b>Eddy County, New Mexico</b>

## Commercial Well Determination

A commercial well determination shall be submitted after production has been established for at least six months.

## Unit Wells

The well sign for a unit well shall include the unit number in addition to the surface and bottom hole lease numbers. This also applies to participating area numbers. If a participating area has not been established, the operator can use the general unit designation, but will replace the unit number with the participating area number when the sign is replaced.

## **A. DRILLING OPERATIONS REQUIREMENTS**

The BLM is to be notified in advance for a representative to witness:

- a. Spudding well (minimum of 24 hours)
- b. Setting and/or Cementing of all casing strings (minimum of 4 hours)
- c. BOPE tests (minimum of 4 hours)

### **Eddy County**

Call the Carlsbad Field Office, 620 East Greene St., Carlsbad, NM 88220,  
(575) 361-2822

1. **Hydrogen Sulfide (H<sub>2</sub>S) monitors shall be installed prior to drilling out the surface shoe. If H<sub>2</sub>S is detected in concentrations greater than 100 ppm, the Hydrogen Sulfide area shall meet Onshore Order 6 requirements, which includes equipment and personnel/public protection items. If Hydrogen Sulfide is encountered, provide measured values and formations to the BLM.**
2. Unless the production casing has been run and cemented or the well has been properly plugged, the drilling rig shall not be removed from over the hole without prior approval. **If the drilling rig is removed without approval – an Incident of Non-Compliance will be written and will be a “Major” violation.**

3. **The operator has proposed to drill multiple wells utilizing a skid/walking rig. Operator shall secure the wellbore on the current well, after installing and testing the wellhead, by installing a blind flange of like pressure rating to the wellhead and a pressure gauge that can be monitored while drilling is performed on the other wells.**
4. **Floor controls are required for 3M or Greater systems. These controls will be on the rig floor, unobstructed, readily accessible to the driller and will be operational at all times during drilling and/or completion activities. Rig floor is defined as the area immediately around the rotary table; the area immediately above the substructure on which the draw works is located, this does not include the dog house or stairway area.**
5. **The record of the drilling rate along with the GR/N well log run from TD to surface (horizontal well – vertical portion of hole) shall be submitted to the BLM office as well as all other logs run on the borehole 30 days from completion. If available, a digital copy of the logs is to be submitted in addition to the paper copies. The Rustler top and top and bottom of Salt are to be recorded on the Completion Report.**

## **B. CASING**

**Changes to the approved APD casing program need prior approval if the items substituted are of lesser grade or different casing size or are Non-API. The Operator can exchange the components of the proposal with that of superior strength (i.e. changing from J-55 to N-80, or from 36# to 40#). Changes to the approved cement program need prior approval if the altered cement plan has less volume or strength or if the changes are substantial (i.e. Multistage tool, ECP, etc.). The initial wellhead installed on the well will remain on the well with spools used as needed.**

**Centralizers required on surface casing per Onshore Order 2.III.B.1.f.**

### **Wait on cement (WOC) for Water Basin:**

**After cementing but before commencing any tests, the casing string shall stand cemented under pressure until both of the following conditions have been met: 1) cement reaches a minimum compressive strength of 500 psi at the shoe, 2) until cement has been in place at least 8 hours. WOC time will be recorded in the driller's log. See individual casing strings for details regarding lead cement slurry requirements.**

**Provide compressive strengths including hours to reach required 500 pounds compressive strength prior to cementing each casing string. Have well specific cement details onsite prior to pumping the cement for each casing string.**

**No pea gravel permitted for remedial or fall back remedial without prior authorization from the BLM engineer.**

**Possibility of water flows in the Salado and Castile.**

**Possibility of lost circulation in the Red beds, Rustler, and Delaware.**

**Abnormal pressures may be encountered in the 3rd Bone Spring and all subsequent formations.**

1. The 13-3/8 inch surface casing shall be set at approximately 1250 feet (in a competent bed below the Magenta Dolomite, which is a Member of the Rustler, and if salt is encountered, set casing at least 25 feet above the salt) and cemented to the surface.
  - a. If cement does not circulate to the surface, the appropriate BLM office shall be notified and a temperature survey utilizing an electronic type temperature survey with surface log readout will be used or a cement bond log shall be run to verify the top of the cement. Temperature survey will be run a minimum of six hours after pumping cement and ideally between 8-10 hours after completing the cement job.
  - b. **Wait on cement (WOC) time for a primary cement job is to include the lead cement slurry.**
  - c. Wait on cement (WOC) time for a remedial job will be a minimum of 4 hours after bringing cement to surface or 500 pounds compressive strength, whichever is greater.
  - d. If cement falls back, remedial cementing will be done prior to drilling out that string.

**Formation below the 13-3/8" shoe to be tested according to Onshore Order 2.III.B.1.i. Test to be done as a mud equivalency test using the mud weight necessary for the pore pressure of the formation below the shoe and the mud weight for the bottom of the hole. Report results to BLM office.**

**Intermediate casing shall be kept fluid filled while running into hole to meet BLM minimum collapse requirements.**

2. The minimum required fill of cement behind the 9-5/8 inch intermediate casing is:

**Operator has proposed DV tool at depth of 6000', but will adjust cement proportionately if moved. DV tool shall be set a minimum of 50' below previous shoe and a minimum of 200' above current shoe. Operator shall submit sundry if DV tool depth cannot be set in this range. If an ECP is used, it is to be set a minimum of 50' below the shoe to provide cement across the shoe. If it cannot be set below the shoe, a CBL shall be run to verify cement coverage.**

a. First stage to DV tool:

- Cement to circulate. If cement does not circulate, contact the appropriate BLM office before proceeding with second stage cement job. Operator should have plans as to how they will achieve circulation on the next stage.

b. Second stage above DV tool:

- Cement to surface. If cement does not circulate, contact the appropriate BLM office.

**Formation below the 9-5/8" shoe to be tested according to Onshore Order 2.III.B.1.i. Test to be done as a mud equivalency test using the mud weight necessary for the pore pressure of the formation below the shoe and the mud weight for the bottom of the hole. Report results to BLM office.**

**Centralizers required through the curve and a minimum of one every other joint.**

3. The minimum required fill of cement behind the 5-1/2 inch production casing is:

- Cement should tie-back at least 200 feet into previous casing string. Operator shall provide method of verification. **Excess calculates to 21% - Additional cement may be required.**

4. If hardband drill pipe is rotated inside casing, returns will be monitored for metal. If metal is found in samples, drill pipe will be pulled and rubber protectors which have a larger diameter than the tool joints of the drill pipe will be installed prior to continuing drilling operations.

### **C. PRESSURE CONTROL**

1. All blowout preventer (BOP) and related equipment (BOPE) shall comply with well control requirements as described in Onshore Oil and Gas Order No. 2 and API 53.
2. Variance approved to use flex line from BOP to choke manifold. Check condition of flexible line from BOP to choke manifold, replace if exterior is damaged or if line fails test. Line to be as straight as possible with no hard bends and is to be anchored according to Manufacturer's requirements. The flexible hose can be exchanged with a hose of equal size and equal or greater pressure rating. **Anchor requirements, specification sheet and hydrostatic pressure test certification matching the hose in service, to be onsite for review. These documents shall be posted in the company man's trailer and on the rig floor.** If the BLM inspector questions the straightness of the hose, a BLM engineer will be contacted and will review in the field or via picture supplied by inspector to determine if changes are required (operator shall expect delays if this occurs).

3. **Operator has proposed a multi-bowl wellhead assembly. This assembly will only be tested when installed on the surface casing. Minimum working pressure of the blowout preventer (BOP) and related equipment (BOPE) required for drilling below the surface casing shoe shall be 10,000 (10M) psi.**
  - a. **Wellhead shall be installed by manufacturer's representatives, submit documentation with subsequent sundry.**
  - b. **If the welding is performed by a third party, the manufacturer's representative shall monitor the temperature to verify that it does not exceed the maximum temperature of the seal.**
  - c. **Manufacturer representative shall install the test plug for the initial BOP test.**
  - d. **Operator shall perform the intermediate casing integrity test to 70% of the casing burst. This will test the multi-bowl seals.**
  - e. **If the cement does not circulate and one inch operations would have been possible with a standard wellhead, the well head shall be cut off, cementing operations performed and another wellhead installed.**

**Variance approved to use a 5M annular. The annular must be tested to full working pressure (5000 psi.)**

**10M system requires an HCR valve, remote kill line and annular to match. The remote kill line is to be installed prior to testing the system and tested to stack pressure.**

4. **The appropriate BLM office shall be notified a minimum of 4 hours in advance for a representative to witness the tests.**
  - a. **In a water basin, for all casing strings utilizing slips, these are to be set as soon as the crew and rig are ready and any fallback cement remediation has been done. The casing cut-off and BOP installation can be initiated four hours after installing the slips, which will be approximately six hours after bumping the plug. For those casing strings not using slips, the minimum wait time before cut-off is eight hours after bumping the plug. BOP/BOPE testing can begin after cut-off or once cement reaches 500 psi compressive strength (including lead when specified), whichever is greater. However, if the float does not hold, cut-off cannot be initiated until cement reaches 500 psi compressive strength (including lead when specified).**
  - b. **The tests shall be done by an independent service company utilizing a test plug not a cup or J-packer.**
  - c. **The test shall be run on a 5000 psi chart for a 2-3M BOP/BOP, on a 10000 psi chart for a 5M BOP/BOPE and on a 15000 psi chart for a 10M BOP/BOPE. If a linear chart is used, it shall be a one hour chart. A circular chart shall have a maximum 2 hour clock. If a twelve hour or twenty-four hour chart is used, tester shall make a notation that it is run with a two hour clock.**



- d. The results of the test shall be reported to the appropriate BLM office.
- e. All tests are required to be recorded on a calibrated test chart. **A copy of the BOP/BOPE test chart and a copy of independent service company test will be submitted to the appropriate BLM office.**
- f. The BOP/BOPE test shall include a low pressure test from 250 to 300 psi. The test will be held for a minimum of 10 minutes if test is done with a test plug and 30 minutes without a test plug. This test shall be performed prior to the test at full stack pressure.
- g. BOP/BOPE must be tested by an independent service company within 500 feet of the top of the **Wolfcamp** formation if the time between the setting of the intermediate casing and reaching this depth exceeds 20 days. This test does not exclude the test prior to drilling out the casing shoe as per Onshore Order No. 2.

#### **D. DRILLING MUD**

Mud system monitoring equipment, with derrick floor indicators and visual and audio alarms, shall be operating before drilling into the **Wolfcamp** formation, and shall be used until production casing is run and cemented.

#### **E. DRILL STEM TEST**

If drill stem tests are performed, Onshore Order 2.III.D shall be followed.

#### **F. WASTE MATERIAL AND FLUIDS**

All waste (i.e. drilling fluids, trash, salts, chemicals, sewage, gray water, etc.) created as a result of drilling operations and completion operations shall be safely contained and disposed of properly at a waste disposal facility. No waste material or fluid shall be disposed of on the well location or surrounding area.

Porto-johns and trash containers will be on-location during fracturing operations or any other crew-intensive operations.

**JAM 011420**