

N. M. Oil Cons. Division

811 S. 1ST ST.

AP A, NM 88210-2834

SUBMIT INPLICATE\* (Other Inst. on reverse side)

FORM APPROVED OMB NO. 1004-0136 Expires: February 28, 1995

Form 3160-3 (July 1992)

UNITED STATES DEPARTMENT OF THE INTERIOR BUREAU OF LAND MANAGEMENT

APPLICATION FOR PERMIT TO DRILL OR DEEPEN

1a. TYPE OF WORK

DRILL [X] DEEPEN [ ]

b. TYPE OF WELL

OIL WELL [ ] GAS WELL [X] OTHER [ ] SINGLE ZONE [ ] MULTIPLE ZONE [ ]

2. NAME OF OPERATOR

YATES PETROLEUM CORPORATION

3. ADDRESS AND TELEPHONE NO.

105 South Fourth Street, Artesia, New Mexico 88210 (505) 748-1471

4. LOCATION OF WELL (Report location clearly and in accordance with any State requirements.)\*

At surface 1500' FSL and 1160' FEL At proposed prod. zone Same

14. DISTANCE IN MILES AND DIRECTION FROM NEAREST TOWN OR POST OFFICE\*

Approximately 20 miles east of Roswell, New Mexico

15. DISTANCE FROM PROPOSED\* LOCATION TO NEAREST PROPERTY OR LEASE LINE, FT. (Also to nearest drlg. unit line, if any)

1160'

16. NO. OF ACRES IN LEASE

2120.0

17. NO. OF ACRES ASSIGNED TO THIS WELL

160

18. DISTANCE FROM PROPOSED LOCATION\* TO NEAREST WELL, DRILLING, COMPLETED, OR APPLIED FOR, ON THIS LEASE, FT.

19. PROPOSED DEPTH

4850'

20. ROTARY OR CABLE TOOLS

Rotary

21. ELEVATIONS (Show whether DF, RT, GR, etc.)

3890'

22. APPROX. DATE WORK WILL START\*

ASAP

23. PROPOSED CASING AND CEMENTING PROGRAM

Table with 5 columns: SIZE OF HOLE, GRADE SIZE OF CASING, WEIGHT PER FOOT, SETTING DEPTH, QUANTITY OF CEMENT. Rows include 12 3/4" hole with 8 5/8" casing and 7 7/8" hole with 4 1/2" casing.

Yates Petroleum Corporation proposes to drill and test the Abo and intermediate formations. Approximately 900' of surface casing will be set and cement circulated. If commercial, production casing will be run and cement circulated back to 3900'. Will perforate and stimulate as needed for production.

MUD PROGRAM: 0-900' FW Gel/paper/LCM; 900'-4400' Brine; 4400'-TD Polyachriliamide.

BOPE PROGRAM: BOPE will be installed on the 8 5/8" casing and tested daily for operational.

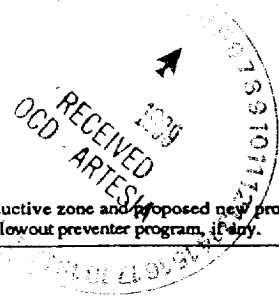

IN ABOVE SPACE DESCRIBE PROPOSED PROGRAM: If proposal is to deepen, give data on present productive zone and proposed new productive zone. If proposal is to drill or deepen directionally, give pertinent data on subsurface locations and measured and true vertical depths. Give blowout preventer program, if any.

24. SIGNED [Signature] TITLE Landman DATE June 8, 1999

(This space for Federal or State office use)

PERMIT NO. APPROVAL DATE

Application approval does not warrant or certify that the applicant holds legal or equitable title to those rights in the subject lease which would entitle the applicant to conduct operations thereon. CONDITIONS OF APPROVAL, IF ANY: Acting

APPROVED BY /S/LARRY D. BRAY Assistant Field Office Manager, Lands and Minerals DATE AUG 03 1999

\*See Instructions On Reverse Side

ROSMETT, N. M.  
BUREAU OF LAND MANAGEMENT  
RECEIVED  
JUN 09 1999

DISTRICT I  
P.O. Box 1980, Hobbs, NM 88240

State of New Mexico  
Energy, Minerals and Natural Resources Department

Form C-102  
Revised February 10, 1994  
Instruction on back  
Submit to Appropriate District Office  
State Lease - 4 Copies  
Fee Lease - 3 Copies

DISTRICT II  
P.O. Drawer DD, Artesia, NM 88210

OIL CONSERVATION DIVISION  
P.O. Box 2088  
Santa Fe, New Mexico 87504-2088

DISTRICT III  
1000 Rio Brazos Rd., Aztec, NM 87410

AMENDED REPORT

WELL LOCATION AND ACREAGE DEDICATION PLAT

API Number	Pool Code	Pool Name Pecos Slope Abo
Property Code	Property Name HORN "YG" FEDERAL	Well Number 2
OGRID No. 025575	Operator Name YATES PETROLEUM CORPORATION	Elevation 3890

Surface Location

UL or lot No.	Section	Township	Range	Lot Idn	Feet from the	North/South line	Feet from the	East/West line	County
1	10	8S	26E		1500	SOUTH	1160	EAST	CHAVES

Bottom Hole Location If Different From Surface

UL or lot No.	Section	Township	Range	Lot Idn	Feet from the	North/South line	Feet from the	East/West line	County

Dedicated Acres 160	Joint or Infill	Consolidation Code	Order No.
------------------------	-----------------	--------------------	-----------

NO ALLOWABLE WILL BE ASSIGNED TO THIS COMPLETION UNTIL ALL INTERESTS HAVE BEEN CONSOLIDATED OR A NON-STANDARD UNIT HAS BEEN APPROVED BY THE DIVISION

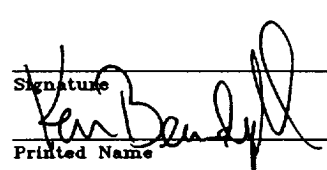
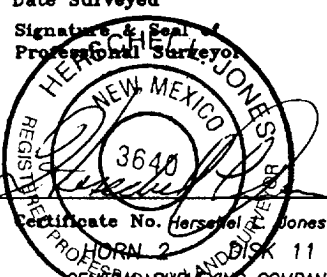
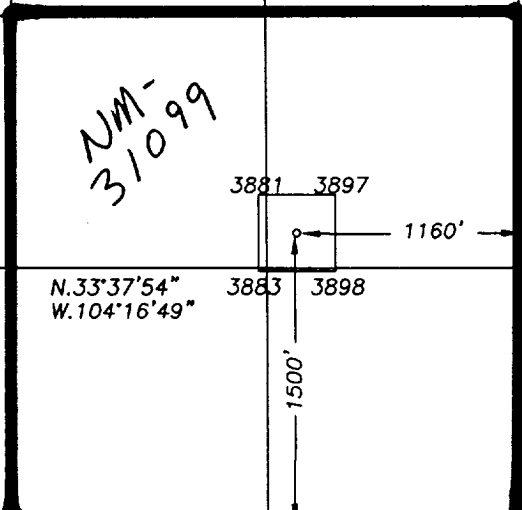
				<p><b>OPERATOR CERTIFICATION</b></p> <p><i>I hereby certify the the information contained herein is true and complete to the best of my knowledge and belief.</i></p> <p>Signature _____              Printed Name            Ken Beardemphl            Title            Landman            Date            June 8, 1999</p>	
				<p><b>SURVEYOR CERTIFICATION</b></p> <p><i>I hereby certify that the well location shown on this plat was plotted from field notes of actual surveys made by me or under my supervision, and that the same is true and correct to the best of my belief.</i></p> <p>Date Surveyed            6/02/99            Signature &amp; Seal of Professional Surveyor              Certificate No. Herschel Jones RLS 3640            HORN 2            GENERAL SURVEYING COMPANY</p>	
					

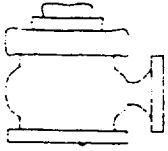

# Yates Petroleum Corporation

BOP-2

## Typical 2,000 psi Pressure System Schematic Double Ram Preventer Stack

**Yates Petroleum Corporation**  
105 SOUTH 4th STREET  
ARTESIA, NEW MEXICO 88210

Horn YG Federal #2  
1500' FSL and 1160' FEL  
Section 10, T8S-R26E  
Chaves County, New Mexico  
NM-31099

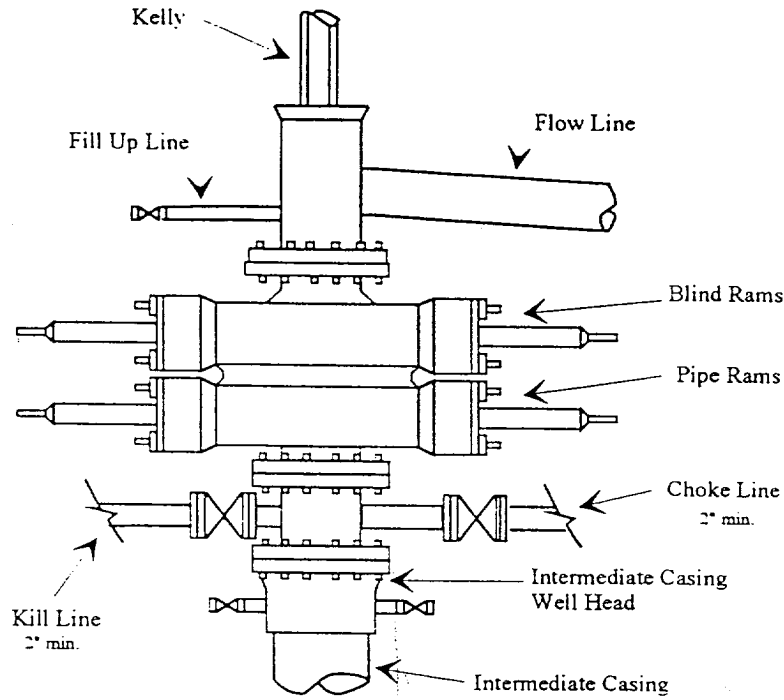

Typical 2,000 psi choke manifold assembly with at least these minimum features

