

UNITED STATES  
DEPARTMENT OF THE INTERIOR  
BUREAU OF LAND MANAGEMENT

N.M. Oil & Gas Div-Dist. 2  
1301 W. Grand Avenue  
Artesia, NM 88210

Approved.  
Budget Bureau No. 1004-0136  
Date: December 31, 1991

95F

APPLICATION FOR PERMIT TO DRILL OR DEEPEN  
DESIGNATION AND SERIAL NO. NM-98122

1a. TYPE OF WORK  
 DRILL  DEEPEN

b. TYPE OF WELL  
 OIL WELL  Gas Well  OTHER  SINGLE ZONE  MULTIZONE

2. NAME OF OPERATOR  
 Mack Energy Corporation *13837*

3. ADDRESS AND TELEPHONE NO.  
 P.O. Box 960, Artesia, NM 88211-0960 (505) 748-1288

4. LOCATION OF WELL (Report location clearly and in accordance with any state requirements)  
 At surface: 990 FSL & 660 FWL  
 At proposed prod. zone: *U.M.*

6. IF INDIAN, ALLOTTEE OR TRIBE NAME

7. UNIT AGREEMENT NAME  
*30490*

8. FARM OR LEASE NAME, WELL NO.  
 Skelly Unit #951

9. API WELL NO.  
*30-015-32436*

10. FIELD AND POOL, OR WILDCAT  
*Order Lake Morrow*

11. SEC., T., R., M., OR BLK. AND SURVEY OR AREA  
 Sec 21-T17S-R31E

12. COUNTY OR PARISH  
 Eddy

13. STATE  
 NM

14. DISTANCE IN MILES AND DIRECTION FROM NEAREST TOWN OR POST OFFICE\*  
 6 miles east of Loco Hills Post Office

15. DISTANCE FROM PROPOSED\* LOCATION TO NEAREST PROPERTY OR LEASE LINE, FT. (Also to nearest drlg. unit line, if any)  
 660

16. NO. OF ACRES IN LEASE  
 4160

17. NO. OF ACRES IN LEASE TO THIS WELL  
 320

18. DISTANCE FROM PROPOSED LOCATION\* TO NEAREST WELL, DRILLING, COMPLETED OR APPLIED FOR, ON THIS LEASE, FT.  
 330

19. PROPOSED DEPTH  
 12,200'

20. ROTARY OR CABLE TOOLS  
 Rotary

21. ELEVATIONS (Show whether DF, RT, GR, etc.)  
 3793' GR

22. APPROX. DATE WORK WILL START\*  
 8/23/02

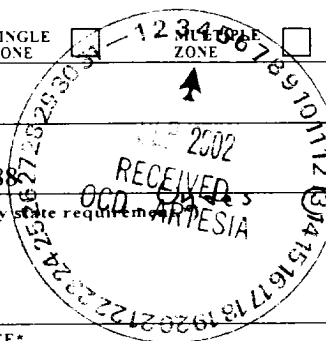

23. PROPOSED CASING AND CEMENTING PROGRAM

SIZE OF HOLE	GRADE, SIZE OF CASING	WEIGHT PER FOOT	SETTING DEPTH	QUANTITY OF CEMENT
17 1/2	J-55, 13 3/8	48	400	Circ
12 1/4	J-55, 8 5/8	32	4500	Sufficient to Circ
7 7/8	S-95 & N-80, 5 1/2	17	12,200	Sufficient to Circ

Mack Energy proposes to drill to a depth sufficient to test the Morrow Formation for gas. If productive, 5 1/2" casing will be cemented. If non-productive, plugging and abandoning in a manor consistent with federal regulation. Specific programs as per Onshore Oil and Gas Order #1 are outlined in the following attachments:

- 1. Surveys  
 Exhibit #1- Well Location Plat  
 Exhibit #2- Vicinity Map  
 Exhibit #3- Location Verification Map
- 2. Drilling Program
- 3. Surface Use & Operating Plan  
 Exhibit #4- One Mile Radius Map  
 Exhibit #5- Production Facilities Layout  
 Exhibit #6- Location Layout
- 4. Certification
- 5. Hydrogen Sulfide Drilling Operation Plan  
 Exhibit #7- H2S Warning Sign  
 Exhibit #8- H2S Safety Equipment
- 6. Blowout Preventers  
 Exhibit #9- BOPE Schematic  
 Exhibit #10- Blowout Preventer Requirements  
 Exhibit #11- Choke Manifold
- 7. Responsibility Statement

**APPROVAL SUBJECT TO GENERAL REQUIREMENTS AND SPECIAL STIPULATIONS ATTACHED**

IN ABOVE SPACE DESCRIBE PROPOSED PROGRAM: If proposal is to deepen, give data on present productive zone and proposed new productive zone. If proposal is to drill or deepen directionally, give pertinent data on subsurface locations and measured and true vertical depths. Give blowout preventer program, if any.

24. SIGNED *Cristina D. Carter* TITLE Production Analyst DATE 7/23/02

(This space for Federal or State office use)

PERMIT NO. \_\_\_\_\_ APPROVAL DATE \_\_\_\_\_

Application approval does not warrant or certify that the applicant holds legal or equitable title to those rights in the subject lease which would entitle the applicant to conduct operations thereon.  
 CONDITIONS OF APPROVAL, IF ANY:

APPROVED BY /s/ JOE G. LARA *ACTING* FIELD MANAGER DATE AUG 30 2002

\*See Instructions On Reverse Side APPROVAL FOR 1 YEAR

DISTRICT I  
P.O. Box 1980, Hobbs, NM 88241-1980

State of New Mexico  
Energy, Minerals and Natural Resources Department

Form C-102  
Revised February 10, 1994  
Submit to Appropriate District Office  
State Lease - 4 Copies  
Fee Lease - 3 Copies

DISTRICT II  
P.O. Drawer DD, Artesia, NM 88211-0719

OIL CONSERVATION DIVISION  
P.O. Box 2088  
Santa Fe, New Mexico 87504-2088

DISTRICT III  
1000 Rio Brazos Rd., Aztec, NM 87410

DISTRICT IV  
P.O. BOX 2088, SANTA FE, N.M. 87504-2088

WELL LOCATION AND ACREAGE DEDICATION PLAT

AMENDED REPORT

API Number	Pool Code	Pool Name Morrow
Property Code 11091	Property Name SKELLY UNIT	Well Number 951
OGRID No. 013837	Operator Name MACK ENERGY CORPORATION	Elevation 3793'

Surface Location

UL or lot No.	Section	Township	Range	Lot Idn	Feet from the	North/South line	Feet from the	East/West line	County
M	21	17-S	31-E		990	SOUTH	660	WEST	EDDY

Bottom Hole Location: If Different From Surface

UL or lot No.	Section	Township	Range	Lot Idn	Feet from the	North/South line	Feet from the	East/West line	County

Dedicated Acres	Joint or Infill	Consolidation Code	Order No.
320			

NO ALLOWABLE WILL BE ASSIGNED TO THIS COMPLETION UNTIL ALL INTERESTS HAVE BEEN CONSOLIDATED OR A NON-STANDARD UNIT HAS BEEN APPROVED BY THE DIVISION

	<p>GEOGRAPHIC COORDINATES SPC NVE NAD 1927 Y = 660646.9 X = 639094.5 LAT = 32°48'55.39"N LONG. = 103°52'50.10"W</p>	<p><b>OPERATOR CERTIFICATION</b></p> <p>I hereby certify the the information contained herein is true and complete to the best of my knowledge and belief.</p> <p><i>Crissa D. Carter</i> Signature</p> <p>Crissa D. Carter Printed Name</p> <p>Production Analyst Title</p> <p>7/23/2002 Date</p>
	<p><b>SURVEYOR CERTIFICATION</b></p> <p>I hereby certify that the well location shown on this plat was plotted from field notes of actual surveys made by me or under my supervision, and that the same is true and correct to the best of my belief.</p> <p>JUNE 27, 2002</p> <p>Date Surveyed <span style="float: right;">AWB</span></p> <p>Signatures &amp; Seal of Professional Surveyor</p> <p><i>Ronald J. Eirson</i> 7/01/02 02.11.0477</p>	
	<p>Certificate No. RONALD J. EIRSON 3239 GARY EIRSON 12641</p>	

# VICINITY MAP

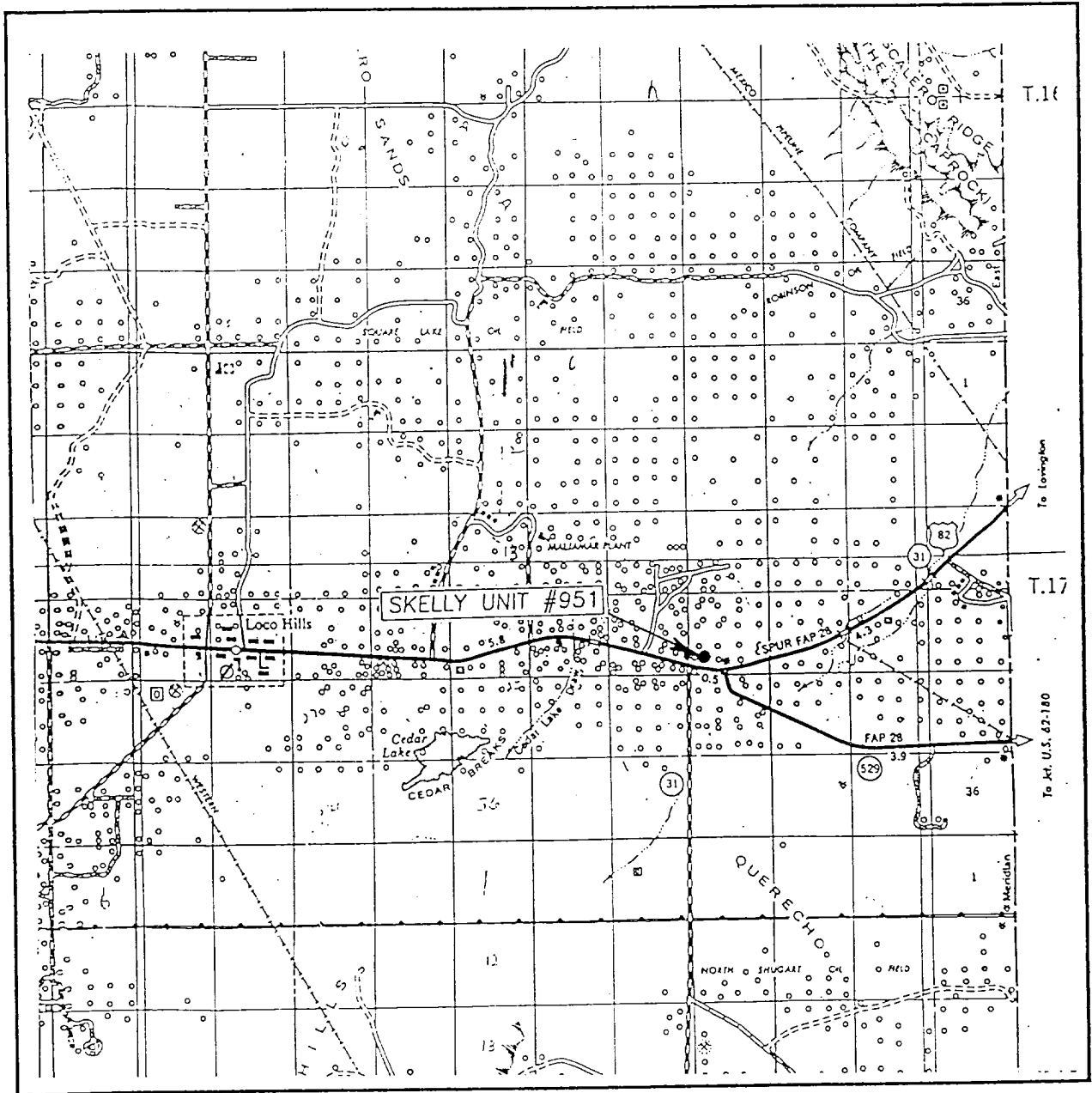

SCALE: 1" = 2 MILES

SEC. 21 TWP. 17-S RGE. 31-E

SURVEY N.M.P.M.

COUNTY EDDY

DESCRIPTION 990' FSL & 660' FWL

ELEVATION 3793'

OPERATOR MACK ENERGY CORPORATION

LEASE SKELLY UNIT

JOHN WEST SURVEYING  
 HOBBS, NEW MEXICO  
 (505) 393-3117

# LOCATION VERIFICATION MAP

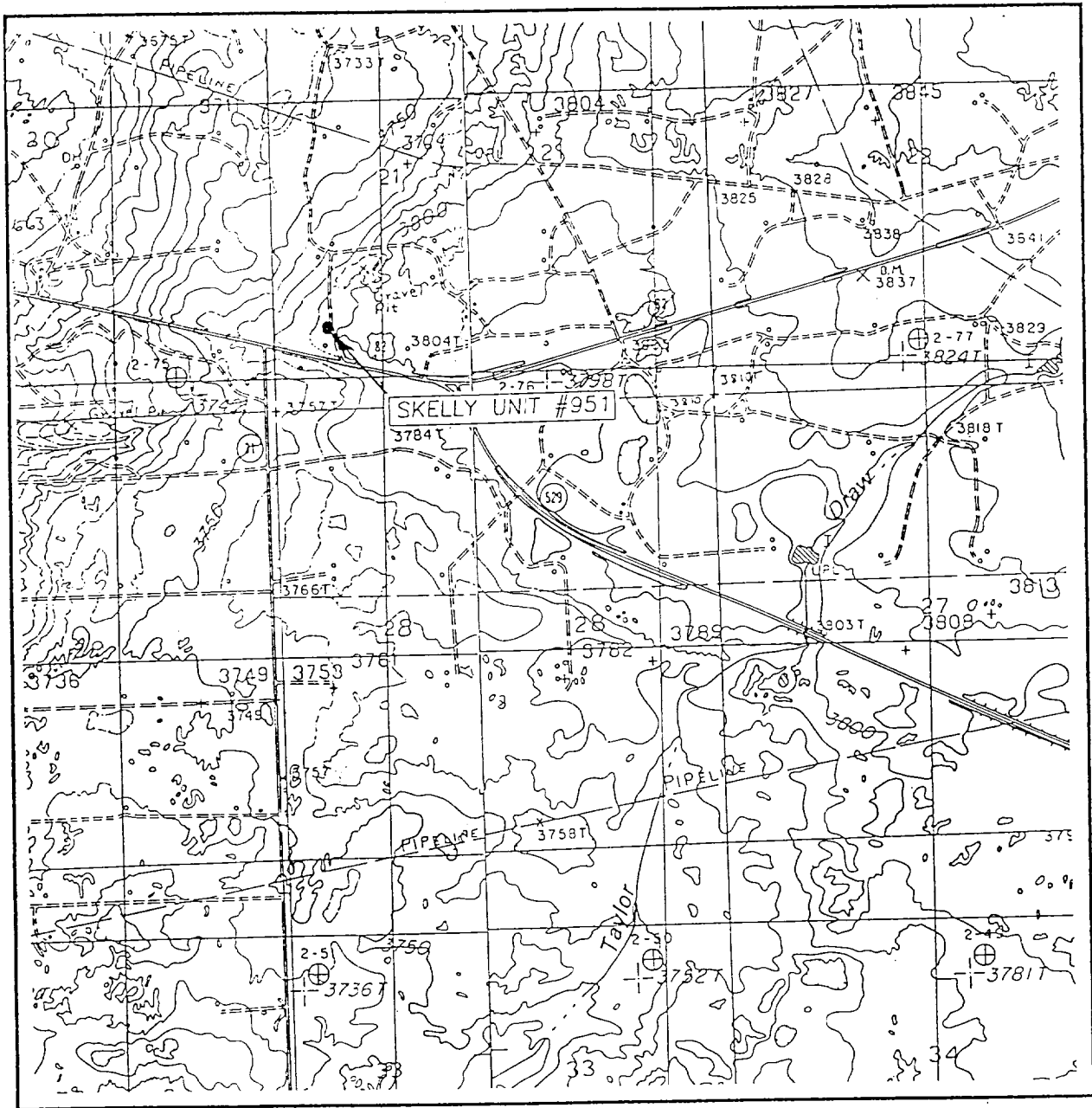

SCALE: 1" = 2000'

CONTOUR INTERVAL: 10'  
 LOCO HILLS,  
 MALJAMAR, N.M.

SEC. 21 TWP. 17-S RGE. 31-E

SURVEY N.M.F.M.

COUNTY EDDY

DESCRIPTION 990' FSL & 660' FWL

ELEVATION 3793'

OPERATOR MACK ENERGY CORPORATION

LEASE SKELLY UNIT

U.S.G.S. TOPOGRAPHIC MAP  
LOCO HILLS, MALJAMAR, N.M.

JOHN WEST SURVEYING  
 HOBBS, NEW MEXICO  
 (505) 393-3117

Attached to Form 60-3  
Mack Energy Corporation  
Skelly Unit #951  
990 FSL & 660 FWL  
SW/4 SW/4, Sec 21 T17S R31E  
Eddy County, NM

## DRILLING PROGRAM

### 1. Geologic Name of Surface Formation

Quaternary

### 2. Estimated Tops of Important Geologic Markers:

Quaternary	Surface	Tubb	6300'	MSSP 12150'
Top of Salt	800'	Abo	7180'	
Base of Salt	1800'	Wolfcamp	8300'	
Yates	1680'	Cisco	9300'	
Queen	2630'	Strawn	10800'	
San Andres	3450'	Atoka	11100'	
Glorietta	4900'	Morrow	11500'	

### 3. Estimated Depths of Anticipated Fresh Water, Oil and Gas:

Water Sand	150'	Fresh Water
Grayburg	3100'	Oil/Gas
San Andres	3450'	Oil/Gas
Paddock	4900'	Oil/Gas
Abo	6500'	Oil/Gas
Wolfcamp	8300'	Oil/Gas
Atoka	11000'	Gas
Morrow	11500'	Gas

No other formations are expected to give up oil, gas or fresh water in measurable quantities. Setting 13 3/8" casing to 400' and circulating cement back to surface will protect the surface fresh water sand. Salt Section will be protected by setting 8 5/8" casing to 4500' and circulating cement back to surface. Any shallower zones above TD, which contain commercial quantities of oil and/or gas, will have cement circulated across them by cementing 5 1/2" production casing, which will be run at TD.

### 4. Casing Program:

Hole Size	Interval	OD Casing	Weight, Grade, Jt, Cond., Type
17 1/2"	0-400'	13 3/8"	48#, J-55, ST&C, New, R-3
12 1/4"	0-4500'	8 5/8"	32#, J-55, ST&C, New, R-3
7 7/8"	0-TD	5 1/2"	17#, S-95 & N-80, LT&C, New, R-3

Attached to Form 3160-3  
Mack Energy Corporation  
Skelly Unit #951  
990 FSL & 660 FWL  
SW/4 SW/4, Sec 21 T17S R31E  
Eddy County, NM

5. **Cement Program:**

13 3/8" Surface Casing: Circulate to Surface with Class C w/2% CaCl<sub>2</sub>.

8 5/8 Intermediate Casing: Circulate to Surface with Class C W/2% CaCl<sub>2</sub>.

5 1/2" Production Casing: Cement Casing with Class C w/6# Salt & 2/10 of 1% CFR-3 per sack. We will run a hole caliper and run sufficient cement to circulate to surface.

6. **Minimum Specifications for Pressure Control:**

The blowout preventer equipment (BOP) shown in Exhibit #9 will consist of a double ram-type (3000 psi or higher WP) preventer. This unit will be hydraulically operated and the ram type preventer will be equipped with blind rams on top of 4 1/2" drill pipe rams on bottom. The BOP will be nipped up on the 13 3/8" surface casing and tested to 70% of the internal yield of the 13 3/8" casing. This will be tested with the Drilling Rig Pumps (which can test to 1500 psi). The BOP will then be nipped up on the 8 5/8" intermediate casing and tested by a 3<sup>rd</sup> party to 2000 psi and used continuously until TD is reached. All BOP's and accessory equipment will be tested to 3000 psi before drilling out of intermediate casing. Pipe rams will be operationally checked each 24-hour period. Blind rams will be operationally checked on each trip out of the hole. These checks will be noted on the daily tour sheets. Other accessories to the BOP equipment (Exhibit #10) will include a Kelly cock and floor safety valve and choke lines and choke manifold (Exhibit #11) with 3000 psi WP rating.

7. **Types and Characteristics of the Proposed Mud System:**

The well will be drilled to TD with a combination of brine, cut brine and polymer mud system. The applicable depths and properties of this system are as follows:

DEPTH	TYPE	WEIGHT	VISCOSITY	WATERLOSS
0-400'	Fresh Water	8.5	28	N.C.
400-4500'	Brine	10	30	N.C.
4500'-TD	Cut Brine	9.1	29	N.C.

Sufficient mud materials to maintain mud properties and meet minimum lost circulation and weight increase requirements will be kept at the well site at all times.

8. **Auxiliary Well Control and Monitoring Equipment:**

- A. Kelly cock will be kept in the drill string at all times.
- B. A full opening drill pipe-stabbing valve with proper drill pipe connections will be on the rig floor at all times.

Attached to Fr  
 Mack Energy  
 Skelly Unit #9:  
 990 FSL & 660  
 SW/4 SW/4, Se  
 Eddy County, W

160-3  
 oration  
 L  
 T17S R31E

**5. Cement Program:**

13 3/8" Surface casing: Circulate to Surface with Class C w/2% CaCl<sub>2</sub>.

8 5/8" Intermediate casing: Circulate to Surface with Class C W/2% CaCl<sub>2</sub>.

5 1/2" Productive Casing: Cement Casing with Class C w/6# Salt & 2/10 of 1% CFR-3 per sack. We will run a hole caliper and run sufficient cement to circulate to surface.

**6. Minimum Specifications for Pressure Control:**

The blowout preventer equipment (BOP) shown in Exhibit #9 will consist of a double ram-type (2000 psi WP) preventer. This unit will be hydraulically operated and the ram type preventer will be equipped with blind rams on top of 4 1/2" drill pipe rams on bottom. The BOP will be nipped up on the 13 3/8" surface casing and tested to 70% of the internal yield of the 13 3/8" casing. This will be tested with the Drilling Rig Pumps (which can test to 1500 psi). The BOP will then be nipped up on the 8 5/8" intermediate casing and tested by a 3<sup>rd</sup> party to 2000 psi and used continuously until TD is reached. All BOP's and accessory equipment will be tested to 2000 psi before drilling out of intermediate casing. Pipe rams will be operationally checked each 24-hour period. Blind rams will be operationally checked on each trip out of the hole. These checks will be noted on the daily tour sheets. Other accessories to the BOP equipment (Exhibit #10) will include a Kelly cock and floor safety valve and choke lines and choke manifold (Exhibit #11) with 2000 psi WP rating.

**7. Types and Characteristics of the Proposed Mud System:**

The well will be drilled to TD with a combination of brine, cut brine and polymer mud system. The applicable depths and properties of this system are as follows:

DEPTH	TYPE	WEIGHT	VISCOSITY	WATERLOSS
0-400'	Fresh Water	8.5	28	N.C.
400-4500'	Brine	10	30	N.C.
4500'-TD	Cut Brine	9.1	29	N.C.

Sufficient mud materials to maintain mud properties and meet minimum lost circulation and weight increase requirements will be kept at the well site at all times.

**8. Auxiliary Well Control and Monitoring Equipment:**

- A. Kelly cock will be kept in the drill string at all times.
- B. A full opening drill pipe-stabbing valve with proper drill pipe connections will be on the rig floor at all times.

Attached to Fo1 160-3  
Mack Energy Corporation  
Skelly Unit #951  
990 FSL & 660 FWL  
SW/4 SW/4, Sec 21 T17S R31E  
Eddy County, NM

**9. Logging, Testing and Coring Program:**

- A. The electric logging program will consist of GR-Dual Laterolog, Spectral Density, Dual Spaced Neutron, CSNG Log and will be ran from T.D. to 8 5/8 casing shoe.
- B. Drill Stem test is not anticipated.
- C. No conventional coring is anticipated.
- D. Further testing procedures will be determined after the 5 1/2" production casing has been cemented at TD based on drill shows and log evaluation.

**10. Abnormal Conditions, Pressures, Temperatures and Potential Hazards:**

No abnormal pressures or temperatures are anticipated. The estimated bottom hole at TD is 110 degrees and estimated maximum bottom hole pressure is 2300 psig. Low levels of Hydrogen sulfide has been detected in producing wells in the area, so H2S may be present while drilling of the well a plan is attached to the Drilling program. No major loss of circulation zones has been reported in offsetting wells.

**11. Anticipated Starting Date and Duration of Operations:**

Road and location work will not begin until approval has been received from the BLM. The anticipated spud date is August 23, 2002. Once commenced, the drilling operation should be finished in approximately 30 days. If the well is productive, an additional 30 days will be required for completion and testing before a decision is made to install permanent facilities.



Attached to Form 3160-3  
Mack Energy Corporation  
Skelly Unit #951  
990 FSL & 660 FWL  
SW/4 SW/4, Sec 21 T17S R31E  
Eddy County, NM

## SURFACE USE AND OPERATING PLAN

### 1. Existing & Proposed Access Roads

- A. The well site and elevation plat for the proposed well is shown in Exhibit #1. It was staked by John West Engineering, Hobbs, NM.
- B. All roads to the location are shown in Exhibit below. The existing lease roads are illustrated in Blue and are adequate for travel during drilling and production operations. Upgrading existing roads prior to drilling well will be done where necessary.
- C. Directions to Location: From Locust Hills, go east 1.10 mile past mile marker 138, turn north 1.10 mile to location.
- D. Routine grading and maintenance of existing roads will be conducted as necessary to maintain their condition as long as any operations continue on this lease.

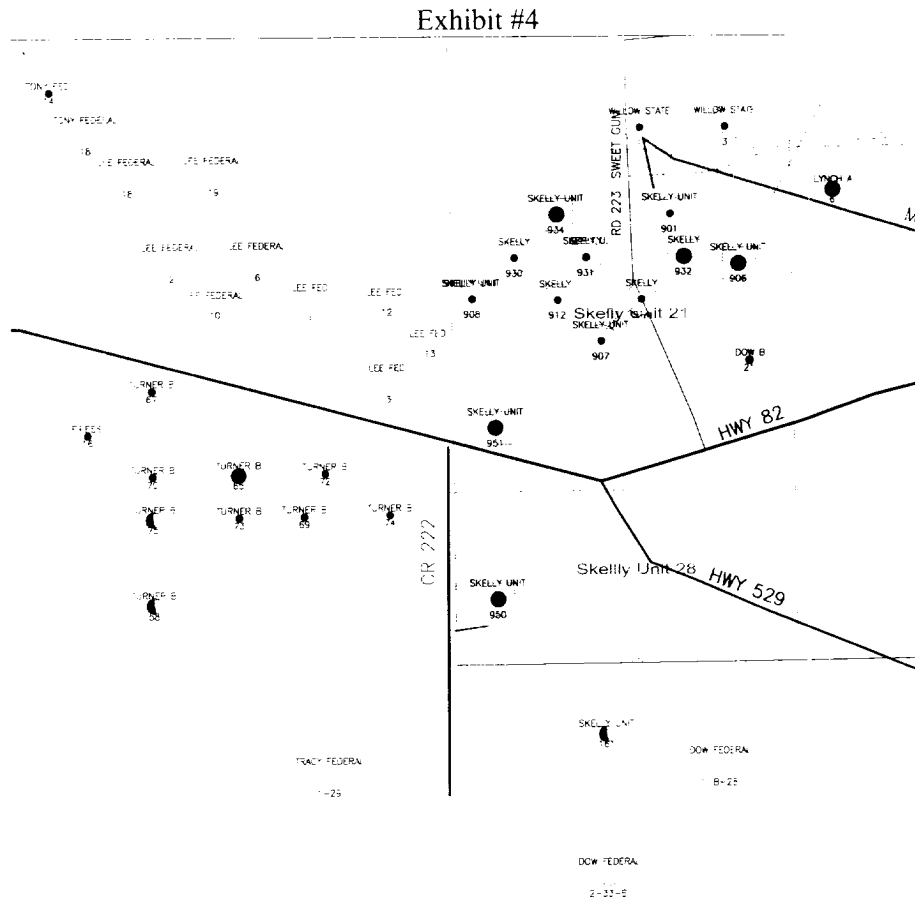

### 2. Proposed Access Road:

Attached to Form 60-3  
Mack Energy Corporation  
Skelly Unit #951  
990 FSL & 660 FWL  
SW/4 SW/4, Sec 21 T17S R31E  
Eddy County, NM

## **2. Proposed Access Road:**

Exhibit #3 shows 0' of new access road to be constructed. The road will be constructed as follows:

- A. The Maximum width of the running surface will be 14'. The road will be crowned and ditched and constructed of 6" rolled and compacted caliche. Ditches will be at 3:1 slope and 4 feet wide. Water will be diverted where necessary to avoid ponding, prevent erosion, maintain good drainage, and to be consistent with local drainage patterns.
- B. The average grade will be less than 1%.
- C. No turnouts are planned.
- D. No culverts, cattleguard, gates, low water crossings or fence cuts are necessary.
- E. Surfacing material will consist of native caliche. Caliche will be obtained from the nearest BLM approved caliche pit or reserve pit area.
- F. The proposed access road as shown in Exhibit #3 has been centerline flagged by John West Engineering, Hobbs, New Mexico.

## **3. Location of Existing Wells & Proposed flow lines for New Wells:**

Exhibit #4 shows all existing wells within a one-mile radius of this well. As shown on this plat there are numerous wells producing Paddock formations. Proposed flow line, in green, will stay on the same location.

## **4. Location of Existing and/or Proposed Facilities:**

- A. Mack Energy Corporation does operate a production facility on this lease.
- B. If the well is productive, contemplated facilities will be as follows:
  - 1) Morrow Completion: Will be sent to the Skelly Unit 951 tank battery. The Facility is shown in Exhibit #5.
  - 2) The tank battery and facilities including all flow lines and piping will be installed according to API specifications.
  - 3) Any additional caliche will be obtained from a BLM approved caliche pit. Any additional construction materials will be purchased from contractors.

Attached to Form 60-3  
 Mack Energy Corporation  
 Skelly Unit #951  
 990 FSL & 660 FWL  
 SW/4 SW/4, Sec 21 T17S R31E  
 Eddy County, NM

- 4) It will be necessary to run electric power if this well is productive. Power will be run by CVE and they will send in a separate plan for power.

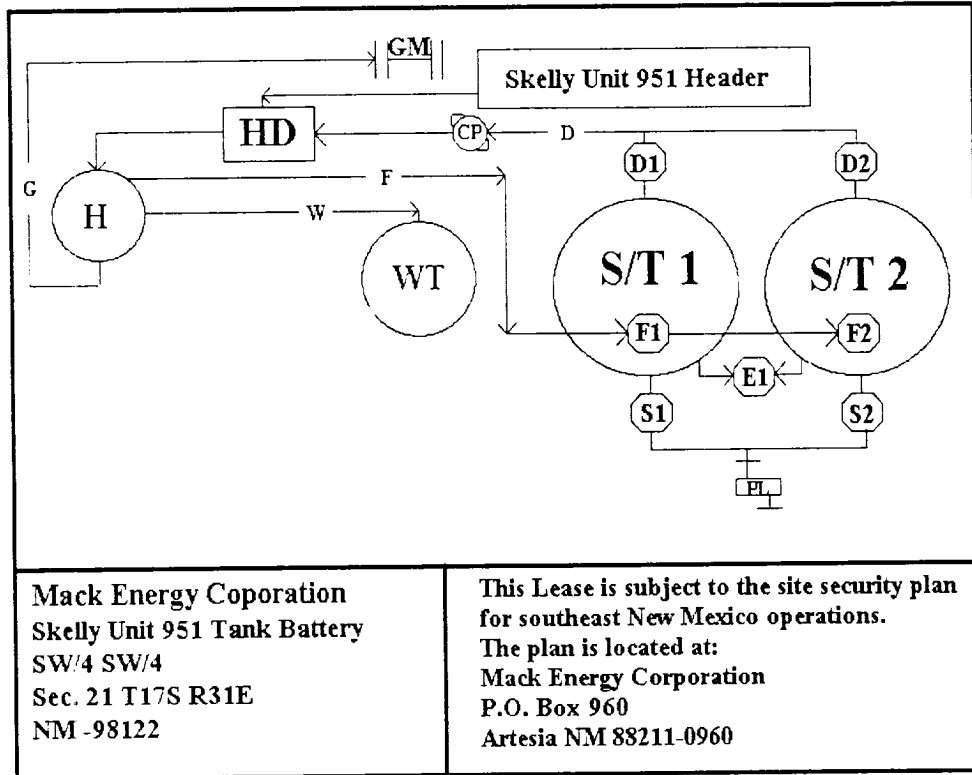

Exhibit #5

- A. If the well is productive, rehabilitation plans are as follows:
- 1) The reserve pit will be back filled after the contents of the pit are dry (within 120 days after the well is completed).
  - 2) Topsoil removed from the drill site will be used to recontour the pit area to the original natural level, as nearly as possible, and reseeded as per BLM specifications.

**5. Location and Type of Water Supply:**

The well will be drilled with combination brine and fresh water mud system as outlined in the drilling program. The water will be obtained from commercial water stations in the area and hauled to location by transport truck over the existing and proposed access roads shown in Exhibit #4. If a commercial fresh water source is nearby, fasline may be laid along existing road ROW's and fresh water pumped to the well. No water well will be drilled on the location.

Attached to Form 50-3  
Mack Energy Corporation  
Skelly Unit #951  
990 FSL & 660 FWL  
SW/4 SW/4, Sec 21 T17S R31E  
Eddy County, NM

**6. Source of Construction Materials:**

All caliche required for construction of the drill pad and proposed new access road (approximately 2500 cubic yards) will be obtained from a BLM approved caliche pit or the reserve pit.

**7. Methods of Handling Water Disposal:**

- A. Drill cuttings not retained for evaluation purposes will be disposed into the reserve pit.
- B. Drilling fluids will be contained in a lined working pit. The reserve pit will contain any excess drilling fluid or flow from the well during drilling, cementing and completion operations. The reserve pit will be an earthen pit, approximately 150' X 100' X 10' deep and fenced on three sides prior to drilling. It will be fenced on the fourth side immediately following rig removal. The reserve pit will be only lined 100' X 100' X 10' the remaining 50' of pit will not be lined and used only as an emergency pit. In the event that it is used fluid will be removed in 48 hours. The reserve pit and working pit will be lined (5-7-mil thickness) to minimize loss of drilling fluids and saturation of the ground with brine water.
- C. Water produced from the well during completion may be disposed into the reserve pit or a steel tank (depending on the rates). After the well is permanently placed on production, produced water will be collected in tanks (fiberglass) until pumped to an approved disposal system; produced oil will be collected in steel tanks until sold.
- D. Garbage and trash produced during drilling or completion operations will be collected in a trash bin and hauled to an approved landfill. All water and fluids will be disposed of into the reserve pit. Salts and other chemicals produced during drilling or testing will be disposed into the reserve pit. No toxic waste or hazardous chemicals will be produced by this operation.
- E. After the rig is moved out and the well is either completed or abandoned, all waste materials will be cleaned up within 30 days. The reserve pit will be completely fenced and kept closed until it has dried. When the reserve pit is dry enough to breakout and backfill and reseeded as per BLM specifications as weather permits. In the event of a dry hole only a dry hole marker will remain.

**8. Ancillary Facilities:**

No airstrip, campsite or other facilities will be built as a result of the operation on this well.

**9. Well Site Layout:**

- A. The drill pad layout, with elevations staked by John West Engineering, is shown in Exhibit #6. Dimensions of the pad and pits are shown. Topsoil, if available, will be stockpiled per BLM specifications. Because the pad is almost level no major cuts will be required.
- B. Diagram below shows the proposed orientation of reserve pit, working pit. There is a possibility that the pits will be moved around depending on Caliche in the area. No permanent living facilities are planned, but a temporary foreman/toolpusher's trailer will be on location during the drilling operations.
- C. The reserve pit will be lined with high quality plastic sheeting (5-7 mil thickness).

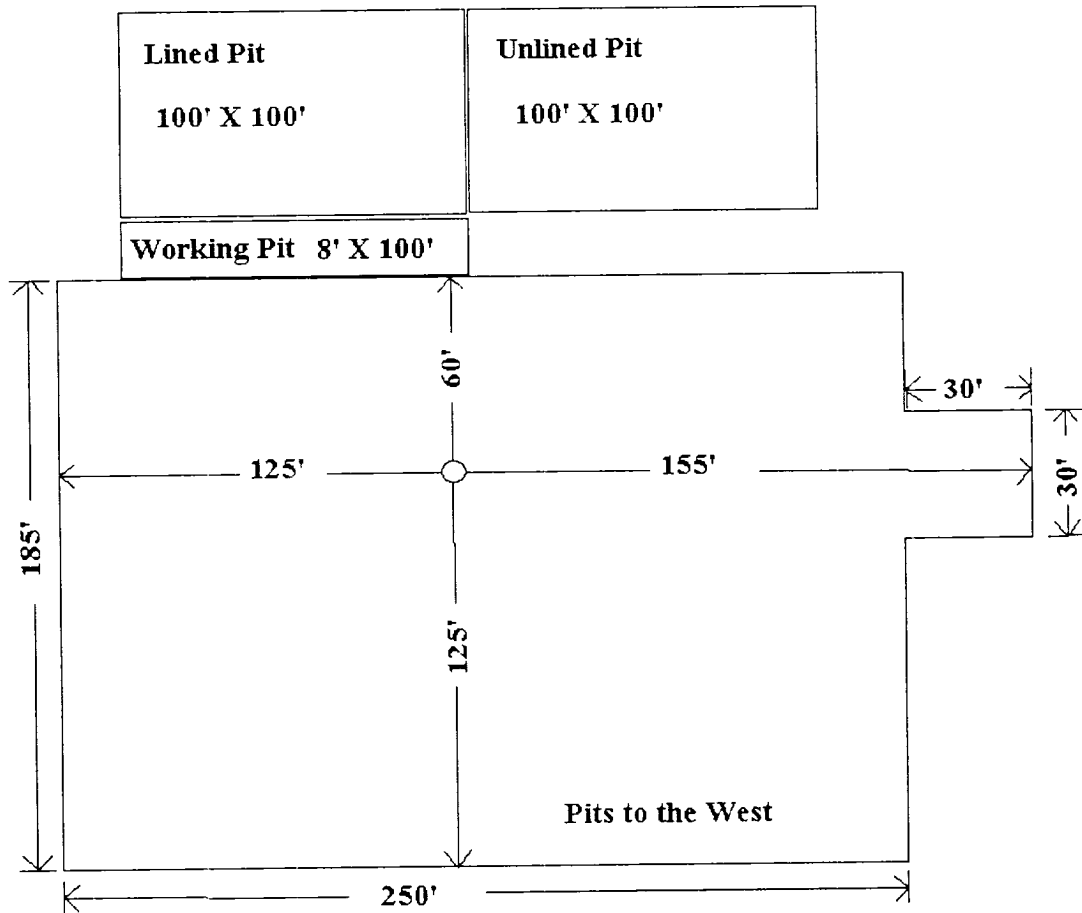

Exhibit #6

Attached to Forr. 60-3  
Mack Energy Corporation  
Skelly Unit #951  
990 FSL & 660 FWL  
SW/4 SW/4, Sec 21 T17S R31E  
Eddy County, NM

**10. Plans for Restoration of the Surface:**

- A. Upon completion of the proposed operations, The pit area, after allowing drying, will be broken out and leveled. The original topsoil will be returned to the pit area, which will be leveled and contoured to as nearly the original topography as possible.
- B. The disturbed area will be revegetated by reseeding during the proper growing season with a seed mixture of native grasses as recommended by the BLM.
- C. Three sides of the reserve pit will be fenced prior to and during drilling operations. At the time that the rig is removed, the reserve pit will be fenced on the rig (fourth) side to prevent livestock from being entrapped. The fencing will remain in place until the pit area is cleaned up and leveled. No oil will be left on the surface of the fluid in the pit.
- D. Upon completion of proposed operations, if the well is completed, the reserve pit area will be treated as outlined above within the same prescribed time. Any additional caliche required for facilities will be obtained from a BLM approved caliche pit. Topsoil removed from the drill site will be used to recontour the pit area to its original natural level and reseeded as per BLM specifications.

**11. Surface Ownership:**

The well site and lease is located entirely on Federal surface. We have notified the surface lessee of the impending operations. According to BLM the lessee is Caviness Cattle Co., 1316 South Main, Portales, NM 88130.

**12. Other Information:**

- A. The area around the well site is grassland and the topsoil is sandy. The vegetation is native scrub grass with sagebrush.
- B. There is no permanent or live water in the immediate area.
- C. A Cultural Resources Examination has been requested and will be forwarded to your office in the near future.

**13. Lessee's and Operator's Representative:**

The Mack Energy Corporation representative responsible for assuring compliance with the surface use plan is as follows:

Matt J. Brewer  
Mack Energy Corporation  
P.O. Box 960  
Artesia, NM 88211-0960  
Phone (505) 748-1288 (office)

Attached to Form 60-3  
Mack Energy Corporation  
Skelly Unit #951  
990 FSL & 660 FWL  
SW/4 SW/4, Sec 21 T17S R31E  
Eddy County, NM

### CERTIFICATION

I hereby certify that I, or person under my direct supervision, have inspected the proposed drill site and access route; that I am familiar with the conditions which currently exist; that the statements made in this plan are to the best of my knowledge, true and correct; and the work associated with the operations proposed herein will be performed by Mack Energy Corporation and its contractors and subcontractors in conformity with this plan and the terms and conditions which it is approved. This statement is subject to the provisions of 18 U.S.C. 1001 for the filing of a false statement.

Date: 7/22/02

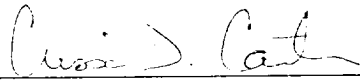
Signed:   
Crissa D. Carter

## Mack Energy Corporation

### Hydrogen Sulfide Drilling Operation Plan

#### I. HYDROGEN SULFIDE TRAINING

All personnel, whether regularly assigned, contracted, or employed on an unscheduled basis, will receive training from a qualified instructor in the following areas prior to commencing drilling operations on this well:

1. The hazards an characteristics of hydrogen sulfide (H2S)
2. The proper use and maintenance of personal protective equipment and life support systems.
3. The proper use of H2S detectors alarms warning systems, briefing areas, evacuation procedures, and prevailing winds.
4. The proper techniques for first aid and rescue procedures.

In addition, supervisory personnel will be trained in the following areas:

1. The effects of H2S on metal components. If high tensile tubular are to be used, personnel well be trained in their special maintenance requirements.
2. Corrective action and shut-in procedures when drilling or reworking a well and blowout prevention and well control procedures.
3. The contents and requirements of the H2S Drilling Operations Plan and Public Protection Plan.

There will be an initial training session just prior to encountering a known or probable H2S zone (within 3 days or 500 feet) and weekly H2S and well control drills for all personnel in each crew. The initial training session shall include a review of the site specific H2S Drilling Operations Plan and the Public Protection Plan. This plan shall be available at the well site. All personnel will be required to carry documentation that they have received the proper training.



## II. H2S SAFETY EQUIPMENT AND SYSTEMS

Note: All H2S safety equipment and systems will be installed, tested, and operational when drilling reaches a depth of 500 feet above, or three days prior to penetrating the first zone containing or reasonable expected to contain H2S.

### 1. Well Control Equipment:

- A. Flare line.
- B. Choke manifold.
- C. Blind rams and pipe rams to accommodate all pipe sizes with properly sized closing unit.
- D. Auxiliary equipment may include if applicable: annular preventer & rotating head.

### 2. Protective equipment for essential personnel:

- A. Mark II Survive air 30-minute units located in the doghouse and at briefing areas, as indicated on well site diagram.

### 3. H2S detection and monitoring equipment:

- A. 1 portable H2S monitors positioned on location for best coverage and response. These units have warning lights and audible sirens when H2S levels of 20 PPM are reached.

### 4. Visual warning systems:

- A. Wind direction indicators as shown on well site diagram (Exhibit #8).
- B. Caution/Danger signs (Exhibit #7) shall be posted on roads providing direct access to location. Signs will be painted a high visibility yellow with black lettering of sufficient size to be readable at a reasonable distance from the immediate location. Bilingual signs will be used, when appropriate. See example attached.

### 5. Mud program:

- A. The mud program has been designed to minimize the volume of H2S circulated to surface. Proper mud weight, safe drilling practices, and the use of H2S scavengers will minimize hazards when penetrating H2S bearing zones.

**6. Metallurgy:**

- A. All drill strings, casings, tubing, wellhead, blowout preventer, drilling spool, kill lines, choke manifold and lines, and valves shall be suitable for H<sub>2</sub>S service.
- B. All elastomers used for packing and seals shall be H<sub>2</sub>S trim.

**7. Communication:**

- A. Radio communications in company vehicles including cellular telephone and 2-way radio.
- B. Land line (telephone) communication at Office.

**8. Well testing:**

- A. Drill stem testing will be performed with a minimum number of personnel in the immediate vicinity, which are necessary to safely and adequately conduct the test. The drill stem testing will be conducted during daylight hours and formation fluids will not be flowed to the surface. All drill-stem-testing operations conducted in an H<sub>2</sub>S environment will use the closed chamber method of testing.
- B. There will be no drill stem testing.

**EXHIBIT #7****WARNING  
YOU ARE ENTERING AN H<sub>2</sub>S  
AUTHORIZED PERSONNEL ONLY**

- 1. BEARDS OR CONTACT LENSES NOT ALLOWED**
- 2. HARD HATS REQUIRED**
- 3. SMOKING IN DESIGNATED AREAS ONLY**
- 4. BE WIND CONSCIOUS AT ALL TIMES**
- 5. CHECK WITH MACK ENERGY FOREMAN AT OFFICE**

**MACK ENERGY CORPORATION****1-505-748-1288**

**DRILLING LOCATION H2S SAFTY EQUIPMENT**  
Exhibit # 8

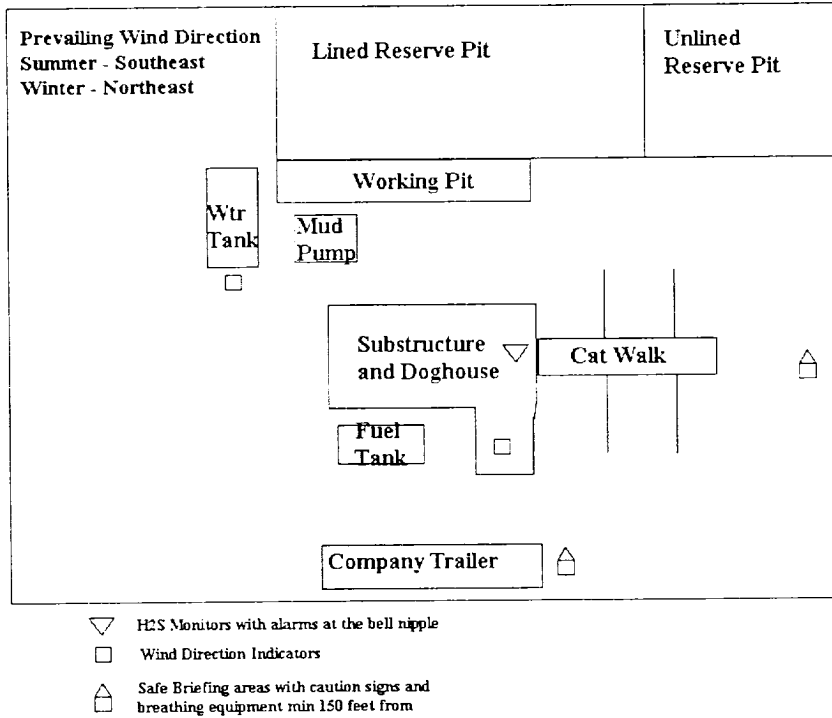

**Attachment to Exhibit #9**  
**NOTES REGARDING THE BLOWOUT PREVENTERS**  
**Skelly Unit #951**  
**Eddy County, New Mexico**

1. Drilling nipple to be so constructed that it can be removed without use of a welder through rotary table opening, with minimum I.D. equal to preventer bore.
2. Wear ring to be properly installed in head.
3. Blow out preventer and all fittings must be in good condition, 2000 psi WP minimum.
4. All fittings to be flanged.
5. Safety valve must be available on rig floor at all times with proper connections, valve to be full 2000 psi WP minimum.
6. All choke and fill lines to be securely anchored especially ends of choke lines.
7. Equipment through which bit must pass shall be at least as large as the diameter of the casing being drilled through.
8. Kelly cock on Kelly.
9. Extension wrenches and hands wheels to be properly installed.
10. Blow out preventer control to be located as close to driller's position as feasible.
11. Blow out preventer closing equipment to include minimum 40-gallon accumulator, two independent sources of pump power on each closing unit installation all API specifications.

# Meck Energy Corporation

## Exhibit #9

### BOPE Schematic

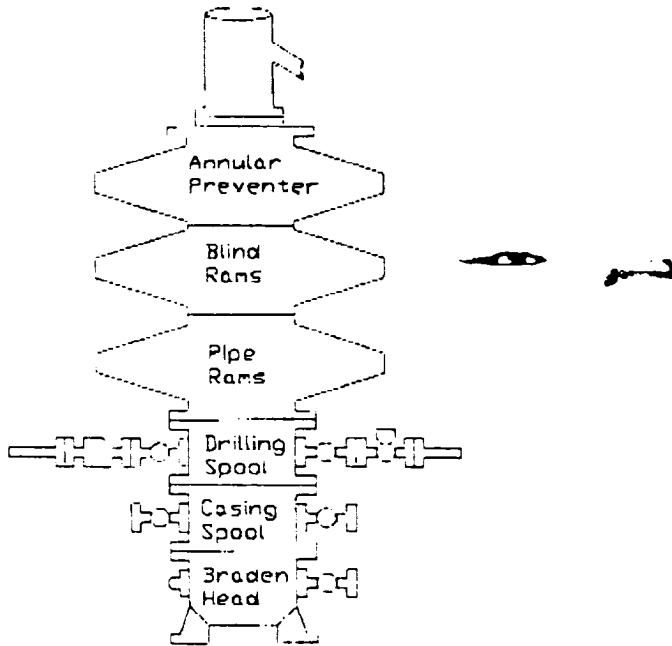

#### Choke Manifold Requirement (3000 psi WP)

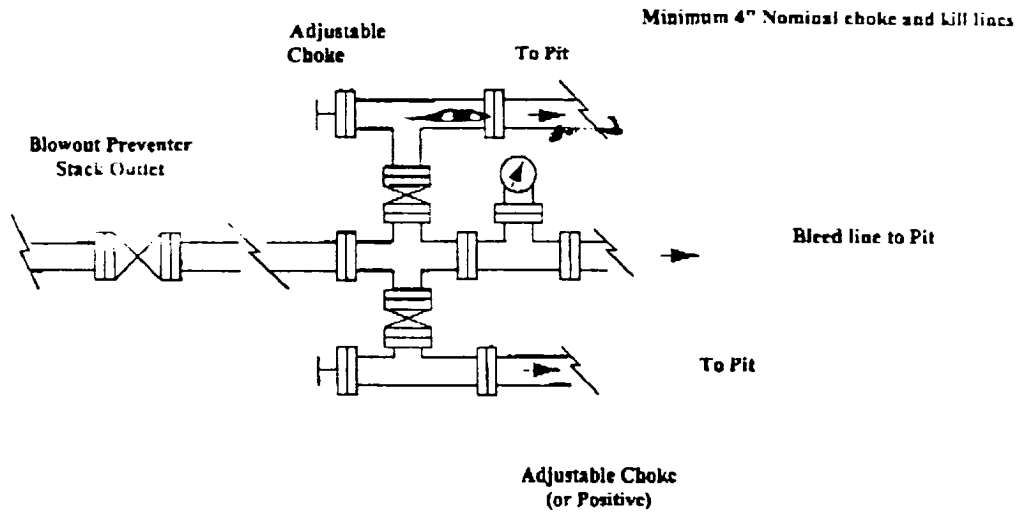

# Mack Energy Corporation

## Exhibit #9 BOPE Schematic

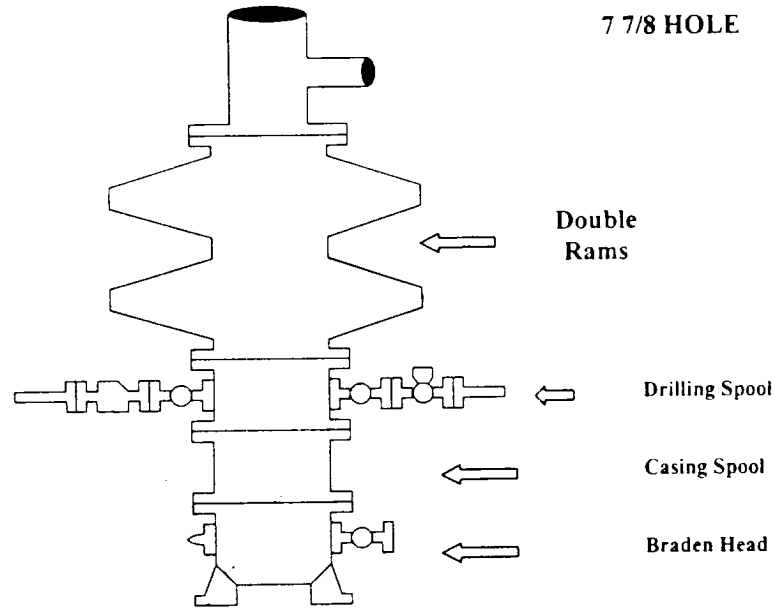

Choke Manifold Requirement (2000 psi WP)  
No Annular Required

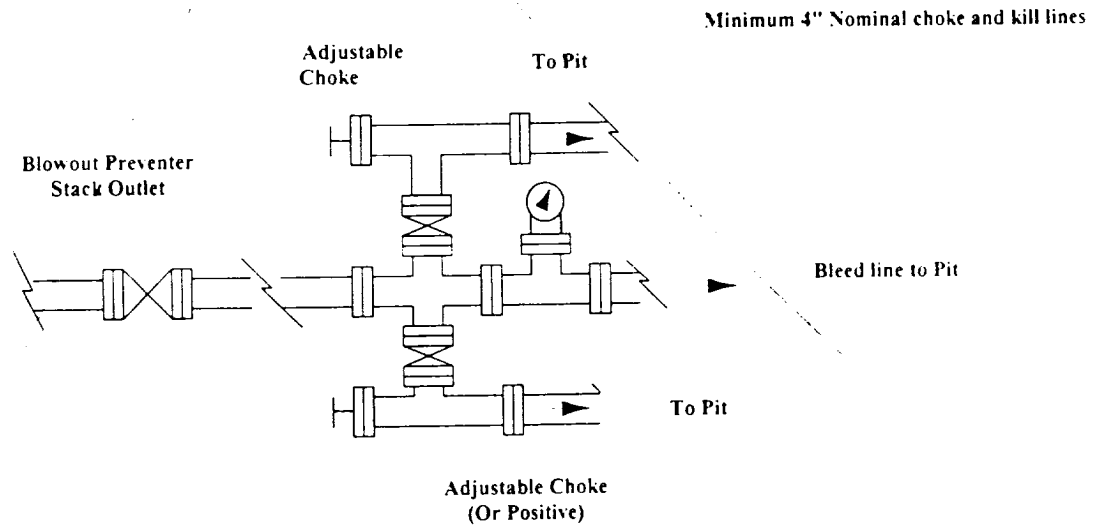

**Mack Energy Corporation**  
**Minimum Blowout Preventer Requirements**  
 3000 psi Working Pressure  
 3 MWP  
 EXHIBIT #10

**Stack Requirements**

NO.	Items	Max. ID.	Min. Nominal
1	Flowline		2"
2	Fill up line		2"
3	Drilling nipple		
4	Annular preventer		
5	Two single or one dual hydraulically operated rams		
6a	Drilling spool with 2" min. kill line and 3" min choke line outlets		2" Choke
6b	2" min. kill line and 3" min choke line outlets in ram. (Alternate to 6a above)		
7	Valve Gate Plug	3 1/8	
8	Gate valve-power operated	3 1/8	
9	Line to choke manifold		3"
10	Valve Gate Plug	2 1/16	
11	Check valve	2 1/16	
12	Casing head		
13	Valve Gate Plug	1 13/16	
14	Pressure gauge with needle valve		
15	Kill line to rig mud pump manifold		2"

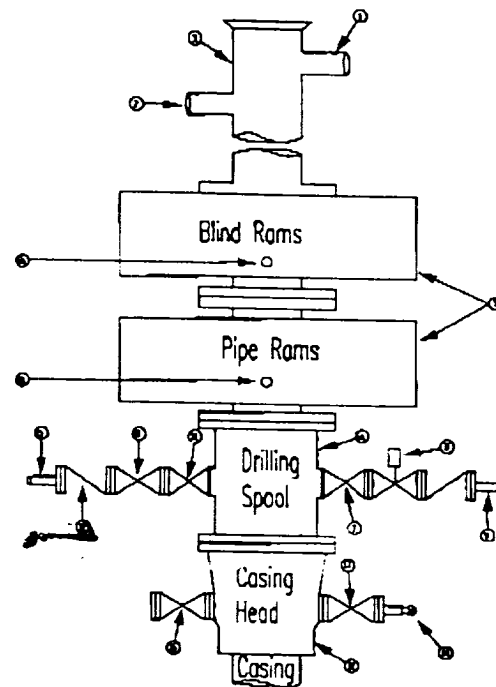

**OPTIONAL**

16	Flanged Valve	1 13/16	
----	---------------	---------	--

**CONTRACTOR'S OPTION TO FURNISH:**

- All equipment and connections above bradenhead or casinghead. Working pressure of preventers to be 3000 psi minimum.
- Automatic accumulator (80 gallon, minimum) capable of closing BOP in 30 seconds or less and, holding them closed against full rated working pressure.
- BOP controls, to be located near drillers' position.
- Kelly equipped with Kelly cock.
- Inside blowout preventer or its equivalent on derrick floor at all times with proper threads to fit pipe being used.
- Kelly saver-sub equipped with rubber casing protector at all times.
- Plug type blowout preventer tester.
- Extra set pipe rams to fit drill pipe in use on location at all times.
- Type RX ring gaskets in place of Type R.

**MFC TO FURNISH:**

- Bradenhead or casing head and side valves.
- Wear bushing. If required.

**GENERAL NOTES:**

- Deviations from this drawing may be made only with the express permission of MEC's Drilling Manager.
- All connections, valves, fittings, piping, etc., subject to well or pump pressure must be flanged (suitable clamp connections acceptable) and have minimum working pressure equal to rated working pressure of preventers up through choke valves must be full opening and suitable for high pressure mud service.
- Controls to be of standard design and each marked, showing opening and closing position.
- Chokes will be positioned so as not to hamper or delay changing of choke beans. Replaceable parts for adjustable choke, or bean sizes, retainers, and choke wrenches to be conveniently located for immediate use.
- All valves to be equipped with hand-wheels or handles ready for immediate use.
- Choke lines must be suitably anchored.
- Handwheels and extensions to be connected and ready for use.
- Valves adjacent to drilling spool to be kept open. Use outside valves except for emergency.
- All seamless steel control piping (3000 psi working pressure) to have flexible joints to avoid stress. Hoses will be permitted.
- Casinghead connections shall not be used except in case of emergency.
- Do not use kill line for routine fill up operations.

**Mack Energy Corporation**  
**Minimum Blowout Preventer Requirements**  
 2000 psi Working Pressure  
 2 MWP  
 EXHIBIT #10

**Stack Requirements**

NO.	Items	Min. I.D.	Min. Nominal
1	Flowline		2"
2	Fill up line		2"
3	Drilling nipple		
4	Annular preventer		
5	Two single or one dual hydraulically operated rams		
6a	Drilling spool with 2" min. kill line and 3" min choke line outlets		2" Choke
6b	2" min. kill line and 3" min. choke line outlets in ram. (Alternate to 6a above)		
7	Valve Gate Plug	3 1/8	
8	Gate valve-power operated	3 1/8	
9	Line to choke manifold		3"
10	Valve Gate Plug	2 1/16	
11	Check valve	2 1/16	
12	Casing head		
13	Valve Gate Plug	1 13/16	
14	Pressure gauge with needle valve		
15	Kill line to rig mud pump manifold		2"

**OPTIONAL**

16	Flanged Valve	1 13/16	
----	---------------	---------	--

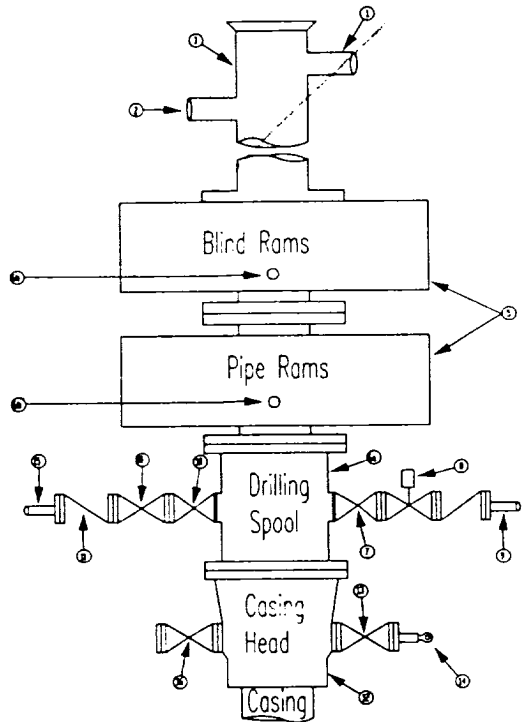

**CONTRACTOR'S OPTION TO FURNISH:**

- All equipment and connections above bradenhead or casinghead Working pressure of preventers to be 2000 psi minimum.
- Automatic accumulator (80 gallon, minimum) capable of closing BOP in 30 seconds or less and, holding them closed against full rated working pressure.
- BOP controls, to be located near drillers' position.
- Kelly equipped with Kelly cock.
- Inside blowout preventer or its equivalent on derrick floor at all times with proper threads to fit pipe being used.
- Kelly saver-sub equipped with rubber casing protector at all times.
- Plug type blowout preventer tester.
- Extra set pipe rams to fit drill pipe in use on location at all times.
- Type RX ring gaskets in place of Type R.

**MEC TO FURNISH:**

- Bradenhead or casing head and side valves.
- Wear bushing. If required.
- 

**GENERAL NOTES:**

- Deviations from this drawing may be made only with the express permission of MEC's Drilling Manager.
- All connections, valves, fittings, piping, etc., subject to well or pump pressure must be flanged (suitable clamp connections acceptable) and have minimum working pressure equal to rated working pressure of preventers up through choke valves must be full opening and suitable for high pressure mud service.
- Controls to be of standard design and each marked, showing opening and closing position.
- Chokes will be positioned so as not to hamper or delay changing of choke beans. Replaceable parts for adjustable choke, or bean

sizes, retainers, and choke wrenches to be conveniently located for immediate use.

- All valves to be equipped with hand-wheels or handles ready for immediate use.
- Choke lines must be suitably anchored.
- Handwheels and extensions to be connected and ready for use.
- Valves adjacent to drilling spool to be kept open. Use outside valves except for emergency.
- All seamless steel control piping (2000 psi working pressure) to have flexible joints to avoid stress. Hoses will be permitted.
- Casinghead connections shall not be used except in case of emergency.
- Do not use kill line for routine fill up operations.



# Mack Energy Corporation

Exhibit #11

## MINIMUM CHOKE MANIFOLD

3,000, 5,000, and 10,000 PSI Working Pressure

2 M will be used or greater

3 MWP - 5 MWP - 10 MWP

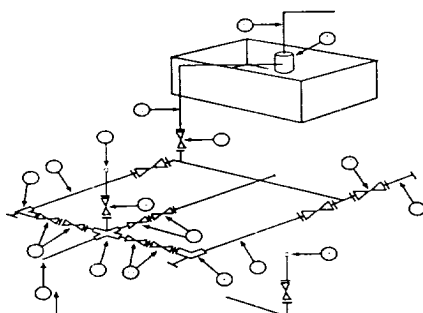

Mud Pit

Reserve Pit

\* Location of separator optional

Below Substructure

### Minimum requirements

No.		3,000 MWP			5,000 MWP			10,000 MWP		
		I.D.	NOMINAL	Rating	I.D.	Nominal	Rating	I.D.	Nominal	Rating
1	Line from drilling Spool		3"	3,000	3"	5,000		3"	10,000	
2	Cross 3" x 3" x 3" x 2"			3,000		5,000			10,000	
2	Cross 3" x 3" x 3" x 2"								10,000	
3	Valve Gate Plug	3 1/8"		3,000	3 1/8"	5,000	3 1/8"		10,000	
4	Valve Gate Plug	1 13/16"		3,000	1 13/16"	5,000	1 13/16"		10,000	
4a	Valves (1)	2 1/16"		3,000	2 1/16"	5,000	2 1/16"		10,000	
5	Pressure Gauge			3,000		5,000			10,000	
6	Valve Gate Plug	3 1/8"		3,000	3 1/8"	5,000	3 1/8"		10,000	
7	Adjustable Choke (3)	2"		3,000	2"	5,000	2"		10,000	
8	Adjustable Choke	1"		3,000	1"	5,000	2"		10,000	
9	Line		3"	3,000		3"		3"	10,000	
10	Line		2"	3,000		2"		2"	10,000	
11	Valve Gate Plug	3 1/8"		3,000	3 1/8"	5,000	3 1/8"		10,000	
12	Line		3"	1,000		3"		3"	2,000	
13	Line		3"	1,000		3"		3"	2,000	
14	Remote reading compund Standpipe pressure quage			3,000		5,000			10,000	
15	Gas Separator		2' x 5'			2' x 5'		2' x 5'		
16	Line		4"	1,000		4"		4"	2,000	
17	Valve Gate Plug	3 1/8"		3,000	3 1/8"	5,000	3 1/8"		10,000	

- (1) Only one required in Class 3M
- (2) Gate valves only shall be used for Class 10 M
- (3) Remote operated hydraulic choke required on 5,000 psi and 10,000 psi for drilling.

### EQUIPMENT SPECIFICATIONS AND INSTALLATION INSTRUCTION

1. All connections in choke manifold shall be welded, studded, flanged or Cameron clamp of comparable rating.
2. All flanges shall be API 6B or 6BX and ring gaskets shall be API RX or BX. Use only BX for 10 MWP.
3. All lines shall be securely anchored.
4. Chokes shall be equipped with tungsten carbide seats and needles, and replacements shall be available.
5. Choke manifold pressure and standpipe pressure gauges shall be available at the choke manifold to assist in regulating chokes. As an alternate with automatic chokes, a choke manifold pressure gauge shall be located on the rig floor in conjunction with the standpipe pressure gauge.
6. Line from drilling spool to choke manifold should be as straight as possible. Lines downstream from chokes shall make turns by large bends or 90 degree bends using bull plugged tees.

**United State Department of the Interior**

**BUREAU OF LAND MANAGEMENT**

Roswell Resource Area

P.O. Drawer 1857

Roswell, New Mexico 88202-1857

**Statement Accepting Responsibility for Operations**

**Operator name:** Mack Energy Corporation  
**Street or box :** P.O. Box 960  
**City, State :** Artesia, NM  
**Zip Code, :** 88211-0960

**The undersigned accepts all applicable terms, conditions, stipulations, and restrictions concerning operations conducted on the leased land or portion thereof, as described below:**

**Lease No.:** NM-98122 Skelly Unit #951

**Legal Description of land:** Sec 21-T17S-R30E SW/4 SW/4

**Formation(s) (if applicable):** Morrow

**Bond Coverage: (State if individually bonded or another's bond)**  
Individually Bonded

**BLM Bond File No.:** 58 59 88

**Authorized Signature:**



Crissa D. Carter

**Title:** Production Analyst

**Date:** 7/23/02