

ADMINISTRATIVE ORDER  
OF THE OIL CONSERVATION DIVISION

Under the provisions of Rule 112-A Amoco Production Company made application to the New Mexico Oil Conservation Division on June 26, 1981, for permission to dually complete its Jicarilla Contract 155 Well No. 28 located in Unit D of Section 31, Township 26 North, Range 5 West, NMPM, Rio Arriba County, New Mexico, in such a manner as to permit production of gas from the Otero-Chacra Pool and from the Mesaverde Formation adjacent to the Gonzales Mesaverde Pool.

NOW, on this 20th day of July, 1981, the Division Director finds:

1. That application has been filed under the provisions of Rule 112-A of the Division's Rules and Regulations;
2. That satisfactory information has been provided that all operators of offset acreage have been duly notified;
3. That no objections have been received within the waiting period as prescribed by said rule.
4. That the proposed dual completion will not cause waste nor impair correlative rights.
5. That the mechanics of the proposed dual completion are feasible and consonant with good conservation practices.

IT IS THEREFORE ORDERED:

That the applicant herein, Amoco Production Company, be and the same is hereby authorized to dually complete its Jicarilla Contract 155 Well No. 28 located in Unit D of Section 31, Township 26 North, Range 5 West, NMPM, Rio Arriba County, New Mexico, in such a manner as to permit production of gas from the Otero-Chacra Pool and from the Mesaverde Formation adjacent to the the Gonzales Mesaverde Pool through parallel strings of tubing.

PROVIDED HOWEVER, That applicant shall complete, operate, and produce said well in accordance with the provisions of Rule 112-A.

PROVIDED FURTHER, That applicant shall take packer-leakage tests upon completion and annually thereafter.

IT IS FURTHER ORDERED: That jurisdiction of this cause is hereby retained for the entry of such further orders as the Division may deem necessary.

DONE at Santa Fe, New Mexico, on the day and year hereinabove designated.

STATE OF NEW MEXICO  
OIL CONSERVATION DIVISION

*Joe D. Ramey*  
JOE D. RAMEY  
Division Director

SEAL





STATE OF NEW MEXICO  
ENERGY AND MINERALS DEPARTMENT

OIL CONSERVATION DIVISION  
AZTEC DISTRICT OFFICE

1000 RIO BRAZOS ROAD  
AZTEC, NEW MEXICO 87410  
(505) 334-6178

OIL CONSERVATION DIVISION  
BOX 2088  
SANTA FE, NEW MEXICO 87501

DATE 6-19-81

RE: Proposed MC α  
Proposed DHC \_\_\_\_\_  
Proposed NSL \_\_\_\_\_  
Proposed SWD \_\_\_\_\_  
Proposed WFX \_\_\_\_\_  
Proposed PMX \_\_\_\_\_

Gentlemen:

I have examined the application dated 6-12-81  
for the Amoco Jicamilla Contract 155 #28 D-31-26N-5W  
Operator Lease and Well No. Unit, S-T-R

and my recommendations are as follows:

Approve  
\_\_\_\_\_  
\_\_\_\_\_  
\_\_\_\_\_  
\_\_\_\_\_

Yours truly,

Frank J. Long

NEW MEXICO OIL CONSERVATION COMMISSION  
SANTA FE, NEW MEXICO  
APPLICATION FOR MULTIPLE COMPLETION

Form C-107  
5-1-61

Operator <b>Amoco Production Company</b>		County <b>Rio Arriba</b>	Date <b>6/11/81</b>
Address <b>501 Airport Drive, Farmington, NM 87401</b>		Lease <b>Jicarilla Contract 155</b>	Well No. <b>28</b>
Location of Well <b>D</b>	Unit <b>31</b>	Township <b>26N</b>	Range <b>5W</b>

1. Has the New Mexico Oil Conservation Commission heretofore authorized the multiple completion of a well in these same pools or in the same zones within one mile of the subject well? YES X NO \_\_\_\_\_
2. If answer is yes, identify one such instance: Order No. MC-2042 ; Operator Lease, and Well No.: Jicarilla Contract 155 No. 24

3. The following facts are submitted:	Upper Zone	Intermediate Zone	Lower Zone
a. Name of Pool and Formation	<b>Otero Chacra</b>		<b>Gonzales Mesaverde</b>
b. Top and Bottom of Pay Section (Perforations)	<b>3761' - 3876'</b>		<b>5100' - 5248'</b>
c. Type of production (Oil or Gas)	<b>Gas</b>		<b>Gas</b>
d. Method of Production (Flowing or Artificial Lift)	<b>Flowing</b>		<b>Flowing</b>

4. The following are attached. (Please check YES or NO)

Yes	No	
<input checked="" type="checkbox"/>	<input type="checkbox"/>	a. Diagrammatic Sketch of the Multiple Completion, showing all casing strings, including diameters and setting depths, centralizers and/or turbolizers and location thereof, quantities used and top of cement, perforated intervals, tubing strings, including diameters and setting depth, location and type of packers and side door chokes, and such other information as may be pertinent.
<input checked="" type="checkbox"/>	<input type="checkbox"/>	b. Plat showing the location of all wells on applicant's lease, all offset wells on offset leases, and the names and addresses of operators of all leases offsetting applicant's lease.
<input checked="" type="checkbox"/>	<input type="checkbox"/>	c. Waivers consenting to such multiple completion from each offset operator, or in lieu thereof, evidence that said offset operators have been furnished copies of the application.*
<input checked="" type="checkbox"/>	<input type="checkbox"/>	d. Electrical log of the well or other acceptable log with tops and bottoms of producing zones and intervals of perforation indicated thereon. (If such log is not available at the time application is filed it shall be submitted as provided by Rule 112-A.)

5. List all offset operators to the lease on which this well is located together with their correct mailing address.

**El Paso Natural Gas, P. O. Box 990, Farmington, New Mexico 87401**

**Caulkins Oil Company, P. O. Box 780, Farmington, New Mexico 87401**

**Conoco, P. O. Box 460, 1000 North Turner, Hobbs, New Mexico 88240**



6. Were all operators listed in Item 5 above notified and furnished a copy of this application? YES X NO \_\_\_\_\_. If answer is yes, give date of such notification June 11, 1981.

CERTIFICATE: I, the undersigned, state that I am the District Superintendent of the Farmington District of Amoco Production Company (company), and that I am authorized by said company to make this report; and that this report was prepared under my supervision and direction and that the facts stated therein are true, correct and complete to the best of my knowledge.

*R. W. Schroeder*  
Signature

\*Should waivers from all offset operators not accompany an application for administrative approval, the New Mexico Oil Conservation Commission will hold the application for a period of twenty (20) days from date of receipt by the Commission's Santa Fe office. If, after said twenty-day period, no protest nor request for hearing is received by the Santa Fe office, the application will then be processed.

NOTE: If the proposed multiple completion will result in an unorthodox well location and/or a non-standard proration unit in one or more of the producing zones, then separate application for approval of the same should be filed simultaneously with this application.

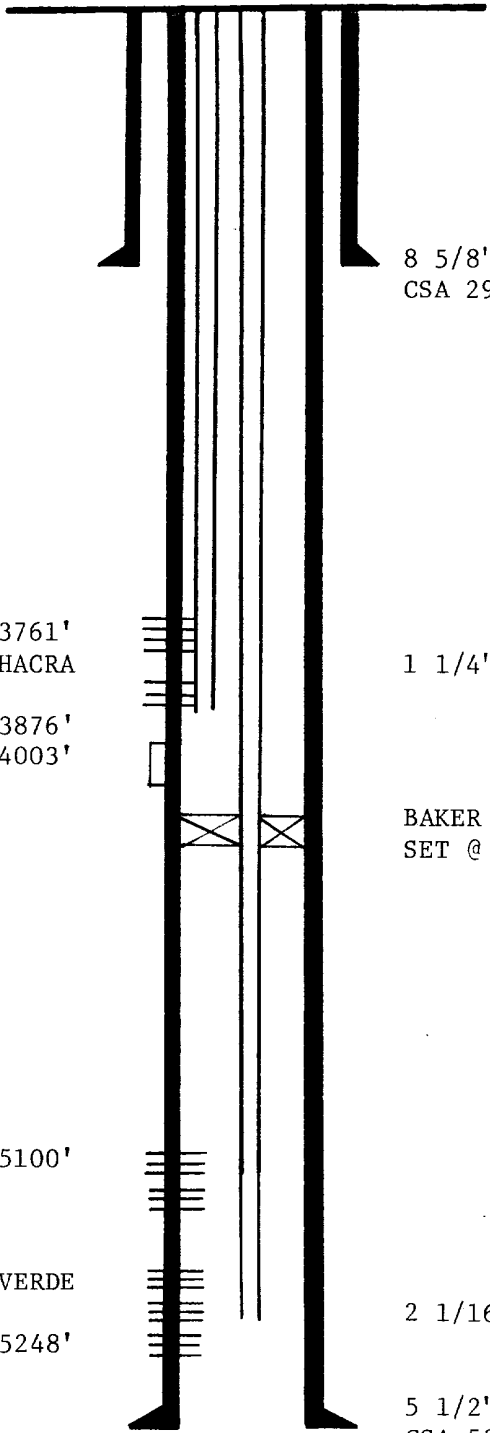

8 5/8" 24# K-55 ST&C  
 CSA 295' X 315 SX CMT

3761'  
 TOTAL OF 80' OF BLAST CHACRA  
 JOINTS ACROSS CHACRA

1 1/4" 2.4# J-55 IJ TBG @ 3897'

3876'  
 DV TOOL 4003'

BAKER MODEL D PACKER  
 SET @ 4052'



5100'

MESAVERDE

2 1/16" 3.4# J-55 IJ TBG @ 5250'

5248'

5 1/2" 14# K-55 ST&C  
 CSA 5395' X 1195 SX CMT

CENTRALIZERS RUN EVERY OTHER JOINT FROM TD TO 4360' AND FROM DV TOOL TO 3683'

Amoco Production Company		SCALE:
JICARILLA CONTRACT 155 #28		DRG. NO.

R6W

R5W

T 26 N

T 25 N

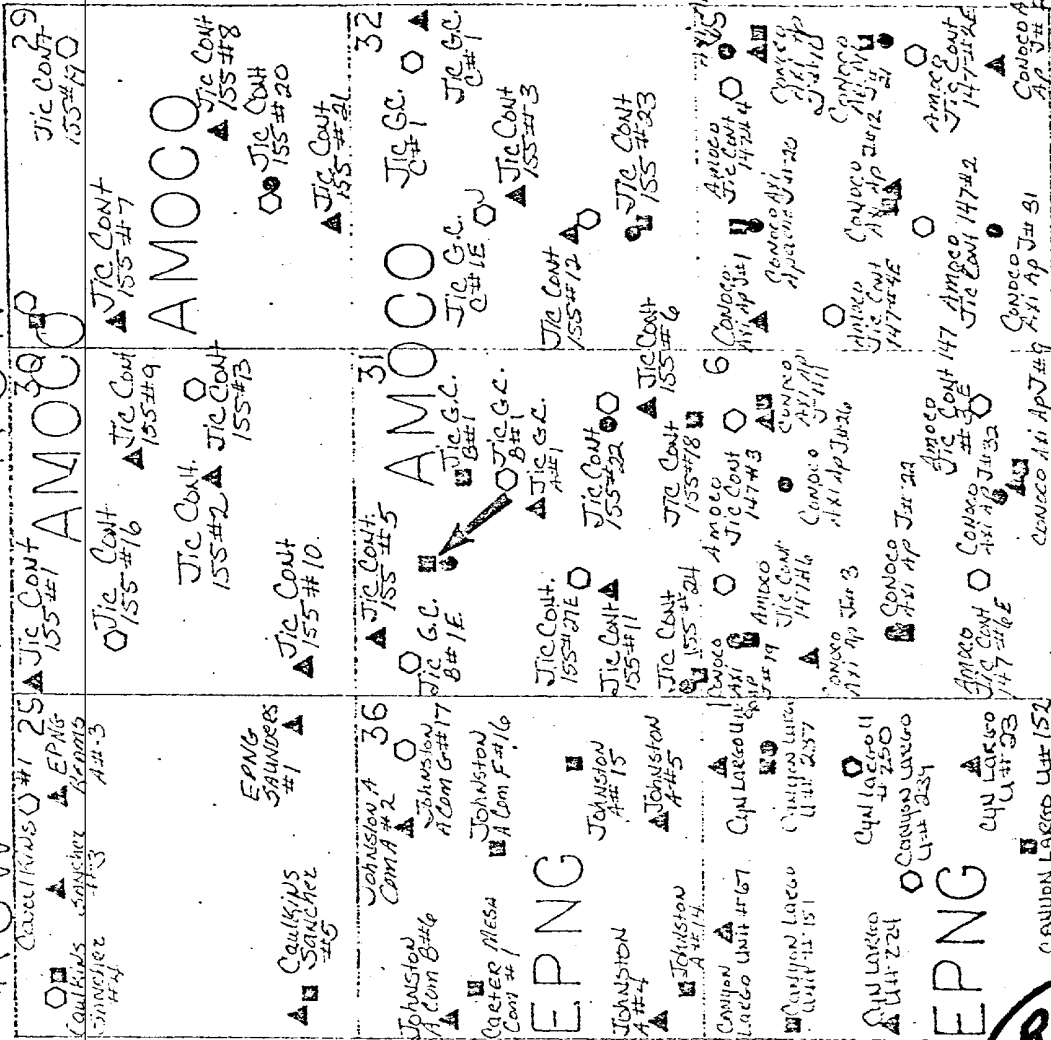

**RECEIVED**  
 JUN 12 1981  
 OIL CON. COM.  
 DIST. 3

○ BASIN DAKOTA WELLS

▲ SOUTH BLANCO PICTURED CLIFFS WELLS

■ OTERO CHACRA WELLS

● GONZALES MESAVERDE WELLS