

*Denny E. Fort*  
DEPUTY OIL & GAS INSPECTOR

DEC 29 1997

*Approved*

Meter Number:90168

Location Name:VALENCIA CANYON UNIT #24

Location:TN-28 RG-04

SC-15 UL-D

2 - Federal

NMOCD Zone:OUTSIDE

Hazard Ranking Score:00

RECEIVED  
APR 14 1997  
OIL CON. DIV.  
DIST. 3

**RATIONALE FOR RISK-BASED CLOSURE OF PRODUCTION PITS  
LOCATED OUTSIDE OF THE VULNERABLE ZONE  
IN THE SAN JUAN BASIN**

This production pit location was ranked according to the criteria in the New Mexico Oil Conservation Division's Unlined Surface Impoundment Closure Guidelines and received a ranking score of zero. The estimated depth to groundwater is greater than 100-feet beneath ground surface (bgs), the pit is not in a well head protection area, and there are no surface water bodies within 1,000 horizontal feet of the pit location.

The primary source, discharge to the pit has been removed. There has been no discharge to the pits for at least 4 years and the pits have been closed for at least one year.

Each pit was backfilled with clean soil and graded in a manner to divert precipitation away from the excavated area. Minimal infiltration of rainfall is expected. Any rainfall that does infiltrate the ground surface must migrate through clean backfill before reaching the residual hydrocarbons.

There is no source material at the ground surface, so direct contact of hydrocarbons with livestock and the populous is not likely.

In general, outside of the vulnerable area and alluvial valleys, bedrock material is generally encountered within 20 feet of the ground surface. Bedrock material in the San Juan Basin consists of interbedded sandstones, shales and clays. According to Freeze and Cherry, 1979, the hydraulic conductivity of the bedrock material are as follows:

Sandstone	$10^{-9}$ to $10^{-13}$ cm/sec
Shale	$10^{-12}$ to $10^{-16}$ cm/sec
Clay	$10^{-12}$ to $10^{-15}$ cm/sec

Based on this information, the residual hydrocarbons should not migrate to groundwater.

Natural process (bioremediation) are degrading the residual hydrocarbon to carbon dioxide and water and will continue until the source is gone, therefore minimizing any impact to the environment.

Based on the above information, it is highly unlikely that any source material will impact groundwater or ever find an exposure pathway to affect human health and therefore El Paso Field Services Company (EPFS) requests closure of this pit location.

FIELD PIT SITE ASSESSMENT FORM



<b>GENERAL</b>	Meter: <u>90168</u> Location: <u>VALENCIA CANYON UNIT #24</u> Operator #: <u>0203</u> Operator Name: <u>AMOCO</u> P/L District: <u>BLOOMFIELD</u> Coordinates: Letter: <u>D</u> Section <u>15</u> Township: <u>28</u> Range: <u>§4 AM</u> Or Latitude _____ Longitude _____ Pit Type: Dehydrator _____ Location Drip: <u>X</u> Line Drip: _____ Other: _____ Site Assessment Date: <u>5-14-94</u> Area: <u>10</u> Run: <u>62</u>																				
<b>SITE ASSESSMENT</b>	<p><b>NMOCD Zone:</b> (From NMOCD Maps)</p> <p style="margin-left: 150px;"><b>Land Type:</b></p> <table style="width:100%; border: none;"> <tr> <td style="width: 150px;">Inside</td> <td style="width: 50px;"><input type="checkbox"/> (1)</td> <td style="width: 50px;">BLM</td> <td style="width: 50px;"><input type="checkbox"/> (1)</td> </tr> <tr> <td>Outside</td> <td><input checked="" type="checkbox"/> (2)</td> <td>State</td> <td><input type="checkbox"/> (2)</td> </tr> <tr> <td></td> <td></td> <td>Fee</td> <td><input type="checkbox"/> (3)</td> </tr> <tr> <td></td> <td></td> <td>Indian</td> <td>_____</td> </tr> <tr> <td></td> <td></td> <td>FOREST</td> <td><input checked="" type="checkbox"/></td> </tr> </table> <p><b>Depth to Groundwater</b></p> <p>Less Than 50 Feet (20 points) <input type="checkbox"/> (1)</p> <p>50 Ft to 99 Ft (10 points) <input type="checkbox"/> (2)</p> <p>Greater Than 100 Ft (0 points) <input checked="" type="checkbox"/> (3)</p> <p><b>Wellhead Protection Area :</b></p> <p>Is it less than 1000 ft from wells, springs, or other sources of fresh water extraction? , or ; Is it less than 200 ft from a private domestic water source? <input type="checkbox"/> (1) YES (20 points) <input checked="" type="checkbox"/> (2) NO (0 points)</p> <p><b>Horizontal Distance to Surface Water Body</b></p> <p>Less Than 200 Ft (20 points) <input type="checkbox"/> (1)</p> <p>200 Ft to 1000 Ft (10 points) <input type="checkbox"/> (2)</p> <p>Greater Than 1000 Ft (0 points) <input checked="" type="checkbox"/> (3)</p> <p>Name of Surface Water Body _____</p> <p>(Surface Water Body : Perennial Rivers, Major Wash, Streams, Creeks, Irrigation Canals, Ditches, Lakes, Ponds)</p> <p>Distance to Nearest Ephemeral Stream <input type="checkbox"/> (1) &lt; 100' (Navajo Pits Only)</p> <p style="margin-left: 150px;"><input type="checkbox"/> (2) &gt; 100'</p> <p><b>TOTAL HAZARD RANKING SCORE: <u>0</u> POINTS</b></p>	Inside	<input type="checkbox"/> (1)	BLM	<input type="checkbox"/> (1)	Outside	<input checked="" type="checkbox"/> (2)	State	<input type="checkbox"/> (2)			Fee	<input type="checkbox"/> (3)			Indian	_____			FOREST	<input checked="" type="checkbox"/>
Inside	<input type="checkbox"/> (1)	BLM	<input type="checkbox"/> (1)																		
Outside	<input checked="" type="checkbox"/> (2)	State	<input type="checkbox"/> (2)																		
		Fee	<input type="checkbox"/> (3)																		
		Indian	_____																		
		FOREST	<input checked="" type="checkbox"/>																		
<b>REMARKS</b>	Remarks : <u>OIL - PARAFFIN LIQUIDS IN PIT ONE PIT ON LOCATION</u>																				

ORIGINAL PIT LOCATION

Original Pit : a) Degrees from North 240° Footage from Wellhead 107'  
b) Length : 24' Width : 24' Depth : 5'

ORIGINAL PIT LOCATION

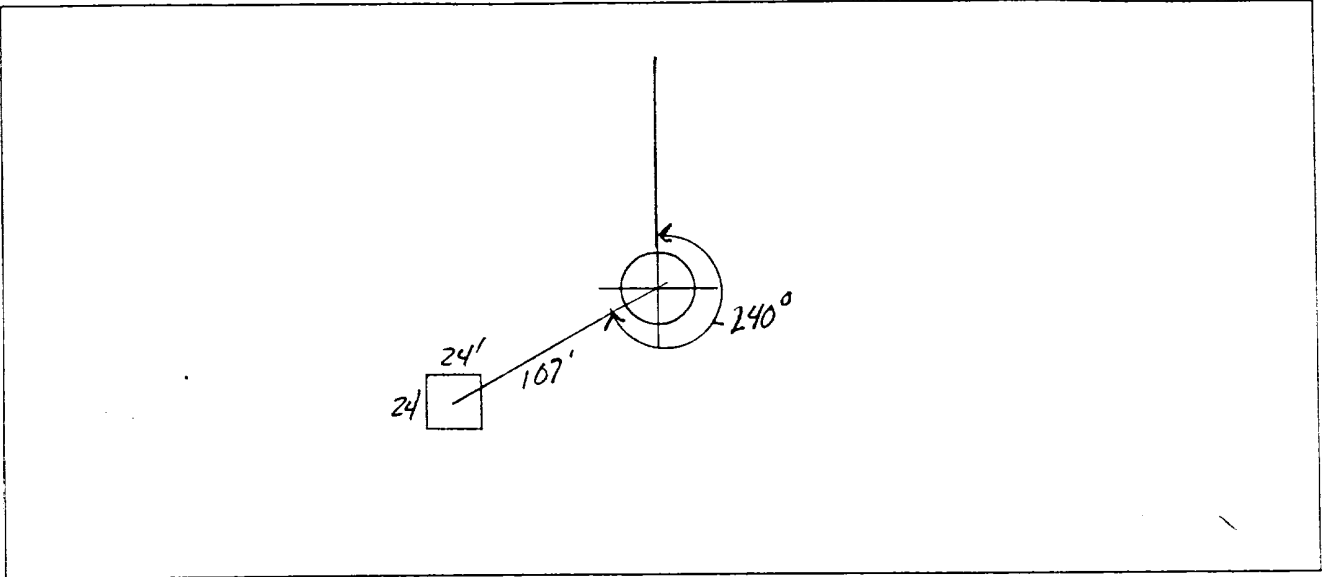

Remarks :

PHOTOGRAPHS AH-5 (19-23)

REMARKS

Completed By:

*Alta S. Harris*

Signature

5-15-94

Date

## FIELD PIT REMEDIATION/CLOSURE FORM

<b>GENERAL</b>	Meter: <u>90168</u> Location: <u>Valencia Canyon</u> Coordinates: Letter: <u>D</u> Section <u>15</u> Township: <u>28</u> Range: <u>4</u> Or Latitude _____ Longitude _____ Date Started : <u>6-16-94</u> Area: <u>10</u> Run: <u>62</u>
<b>FIELD OBSERVATIONS</b>	Sample Number(s): <u>VW 315</u> Sample Depth: <u>12'</u> Feet Final PID Reading <u>47</u> PID Reading Depth <u>12'</u> Feet Yes No Groundwater Encountered <input type="checkbox"/> (1) <input checked="" type="checkbox"/> (2) Approximate Depth _____ Feet
<b>CLOSURE</b>	Remediation Method : Excavation <input type="checkbox"/> (1) Approx. Cubic Yards _____ Onsite Bioremediation <input type="checkbox"/> (2) Backfill Pit Without Excavation <input checked="" type="checkbox"/> (3) Soil Disposition: Envirotech <input type="checkbox"/> (1) <input type="checkbox"/> (3) Tierra Other Facility <input type="checkbox"/> (2) Name: _____ Pit Closure Date: <u>6-16-94</u> Pit Closed By: <u>BEZ</u>
<b>REMARKS</b>	Remarks : <u>Wet Pit - EPN/G line markers</u> _____ _____
	Signature of Specialist: <u>Bob Wilson</u>



**FIELD SERVICES LABORATORY  
ANALYTICAL REPORT  
PIT CLOSURE PROJECT - Soil**

**SAMPLE IDENTIFICATION**

	Field ID	Lab ID
SAMPLE NUMBER:	VW 215	945468
MTR CODE   SITE NAME:	90168	N/A
SAMPLE DATE   TIME (Hrs):	6-16-94	1515
SAMPLED BY:	N/A	
DATE OF TPH EXT.   ANAL.:	6-20-94	6/20/94
DATE OF BTEX EXT.   ANAL.:	N/A	N/A
TYPE   DESCRIPTION:	VG	grey course sand & clay

REMARKS: \_\_\_\_\_

**RESULTS**

PARAMETER	RESULT	UNITS	QUALIFIERS			
			DF	Q	M(g)	V(ml)
BENZENE		MG/KG				
TOLUENE		MG/KG				
ETHYL BENZENE		MG/KG				
TOTAL XYLENES		MG/KG				
TOTAL BTEX		MG/KG				
TPH (418.1)	240 244	MG/KG <i>div 6/22/94</i>			1.99	28
HEADSPACE PID	47	PPM				
PERCENT SOLIDS	84.9	%				

- TPH is by EPA Method 418.1 and BTEX is by EPA Method 8020 -

The Surrogate Recovery was at N/A % for this sample All QA/QC was acceptable.  
Narrative: \_\_\_\_\_

DF = Dilution Factor Used

Approved By: John L. Lewis

Date: 7/21/94

\*\*\*\*\*  
 Test Method for \*  
 Oil and Grease and Petroleum Hydrocarbons \*  
 in Water and Soil \*  
 \*  
 Perkin-Elmer Model 1600 FT-IR \*  
 Analysis Report \*  
 \*\*\*\*\*

94/06/20 14:09

Sample identification  
 P45468

Initial mass of sample, g  
 1.990

Volume of sample after extraction, ml  
 13.000

Petroleum hydrocarbons, ppm  
 144,247

Net absorbance of hydrocarbons (2930 cm-1)  
 1.033

