

UNITED STATES
DEPARTMENT OF THE INTERIOR
BUREAU OF LAND MANAGEMENT

FORM APPROVED
OMB NO. 1004-0135
Expires: November 30, 2000

SUNDRY NOTICES AND REPORTS ON WELLS
Do not use this form for proposals to drill or to re-enter an abandoned well. Use form 3160-3 (APD) for such proposals.

5. Lease Serial No.
NMSF - 078039

6. If Indian, Allottee or Tribe Name

7. If Unit or CA/Agreement, Name and/or No.

SUBMIT IN TRIPLICATE - Other instructions on reverse side.

1. Type of Well <input type="checkbox"/> Oil Well <input checked="" type="checkbox"/> Gas Well <input type="checkbox"/> Other		8. Well Name and No. BARNES LS 2A	
2. Name of Operator AMOCO PRODUCTION COMPANY		Contact: MARY CORLEY E-Mail: corleym1@bp.com	9. API Well No. 30-045-22395
3a. Address P.O. BOX 3092 HOUSTON, TX 77253	3b. Phone No. (include area code) Ph: 281.366.4491 Fx: 281.366.0700		10. Field and Pool, or Exploratory BLANCO PC & BLANCO MV
4. Location of Well (Footage, Sec., T., R., M., or Survey Description) Sec 22 T32N R11W NWNW 1050FNL 1000FWL			11. County or Parish, and State SAN JUAN COUNTY, NM

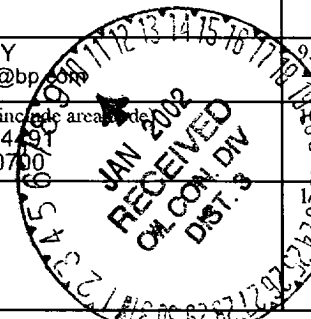

12. CHECK APPROPRIATE BOX(ES) TO INDICATE NATURE OF NOTICE, REPORT, OR OTHER DATA

TYPE OF SUBMISSION	TYPE OF ACTION			
<input checked="" type="checkbox"/> Notice of Intent	<input type="checkbox"/> Acidize	<input type="checkbox"/> Deepen	<input type="checkbox"/> Production (Start/Resume)	<input type="checkbox"/> Water Shut-Off
<input type="checkbox"/> Subsequent Report	<input type="checkbox"/> Alter Casing	<input type="checkbox"/> Fracture Treat	<input type="checkbox"/> Reclamation	<input type="checkbox"/> Well Integrity
<input type="checkbox"/> Final Abandonment Notice	<input type="checkbox"/> Casing Repair	<input type="checkbox"/> New Construction	<input type="checkbox"/> Recomplete	<input checked="" type="checkbox"/> Other Subsurface Commi ng
	<input type="checkbox"/> Change Plans	<input type="checkbox"/> Plug and Abandon	<input type="checkbox"/> Temporarily Abandon	
	<input type="checkbox"/> Convert to Injection	<input type="checkbox"/> Plug Back	<input type="checkbox"/> Water Disposal	

13. Describe Proposed or Completed Operation (clearly state all pertinent details, including estimated starting date of any proposed work and approximate duration thereof. If the proposal is to deepen directionally or recomplete horizontally, give subsurface locations and measured and true vertical depths of all pertinent markers and zones. Attach the Bond under which the work will be performed or provide the Bond No. on file with BLM/BIA. Required subsequent reports shall be filed within 30 days following completion of the involved operations. If the operation results in a multiple completion or recompletion in a new interval, a Form 3160-4 shall be filed once testing has been completed. Final Abandonment Notices shall be filed only after all requirements, including reclamation, have been completed, and the operator has determined that the site is ready for final inspection.)

Amoco Production Company request permission to convert the subject well from a dual string completion to a single string completion and commingle production downhole from the Blanco Pictured Cliffs & Blanco Mesaverde Pools as per the attached procedure.

The Blanco Pictured Cliffs (72359) & the Blanco Mesaverde (72319) Pools are Pre-Approved Pools for Downhole Commingling per NMOCD order R-11363.

The working, overriding, and royalty interest owners in the proposed commingled pools are identical, therefore, no notification of this application need be submitted via certified mail.

Production is proposed to be allocated based on actual production from both the Pictured Cliffs and Mesaverde Pools as reflected on the attached procedure.

14. I hereby certify that the foregoing is true and correct.

Electronic Submission #9867 verified by the BLM Well Information System
For AMOCO PRODUCTION COMPANY, sent to the Farmington

Name (Printed/Typed)	MARY CORLEY	Signature		Title	AUTHORIZED REPRESENTATIVE
		(Electronic Submission)		Date	12/26/2001

THIS SPACE FOR FEDERAL OR STATE OFFICE USE

Approved By	<u>/s/ Jim Lovato</u>	Title		Date	JAN - 7 2002
Conditions of approval, if any, are attached. Approval of this notice does not warrant or certify that the applicant holds legal or equitable title to those rights in the subject lease which would entitle the applicant to conduct operations thereon.				Office	

Title 18 U.S.C. Section 1001 and Title 43 U.S.C. Section 1212, make it a crime for any person knowingly and willfully to make to any department or agency of the United States any false, fictitious or fraudulent statements or representations as to any matter within its jurisdiction.

**** ORIGINAL ** ORIGINAL ** ORIGINAL ** ORIGINAL ** ORIGINAL ** ORIGINAL ** ORIGINAL ****

Additional data for EC transaction #9867 that would not fit on the form

32. Additional remarks, continued

Commingling Production Downhole in the subject well from the proposed Pools will not reduce the value of the total remaining production.

Barnes LS 2A

Downhole commingle Pictured Cliffs and Mesa Verde

ALLOCATION – FIXED % BASED ON 2001 PRODUCTION JANUARY - AUGUST

<u>POOLS</u>	<u>GAS</u>	<u>%</u>	<u>OIL</u>	<u>%</u>
Blanco Pictured Cliffs	46749 MCF	68%	0 BO	0%
Blanco Mesaverde	21687 MCF	32%	14 BO	100%

1. Check anchors. Check and record tubing, casing, and Bradenhead pressures. Tag and flag valves and bleed flow line pressure to zero. MIRU workover rig.
2. Blow down wellhead. *If necessary, kill with 2% KCl water.*
3. ND wellhead. NU BOPs and diversion spool with 3" outlets and 3" pipe to the blow tank. Pressure test BOPs to 500 psi.
4. Tally OH with short string of tubing (1-1/4", 2.33#, J-55 @ 3282') and visually inspect for potential hole and scale.
5. Tally OH with long string of tubing (2-3/8", 4.7#, J-55 @ 5733') and visually inspect for potential hole and scale.

Contingency: If tubing is in poor condition, replace as necessary.

Contingency: If scale is detected on the tubing, consult engineer about acidizing the well.

6. Pull or retrieve packer @ 3372'.
7. Cleanout fill to PBTD at 5842'.
8. Rabbit tubing and RIH with 2-3/8" production tubing with a muleshoe, F-nipple, and plug on bottom. Fill tubing with 2% KCl while RIH and periodically pressure test to 500 psi. Replace any joints that fail pressure test.
9. Land 2-3/8" production tubing @ +/- 5733'.
10. Swab water from the tubing using the sandline. RU slickline and run gauge ring for 2-3/8" tubing. Pull plug, then RD slickline unit. Clean out to PBTD. Flow to cleanup tank.
11. ND BOPs. NU WH. Notify pumper that well is ready to be returned to production. Swab in well with sandline and flow well for several hours on a choke to ensure well is unloaded and ready to produce before turning over to pumper to return to production.

Barnes LS 2A

API No: 3004522395

Spud Date: 04/27/1977
 Completion Date: 08/08/1977

Location: T32N, R11W, Sec. 22 NW/4

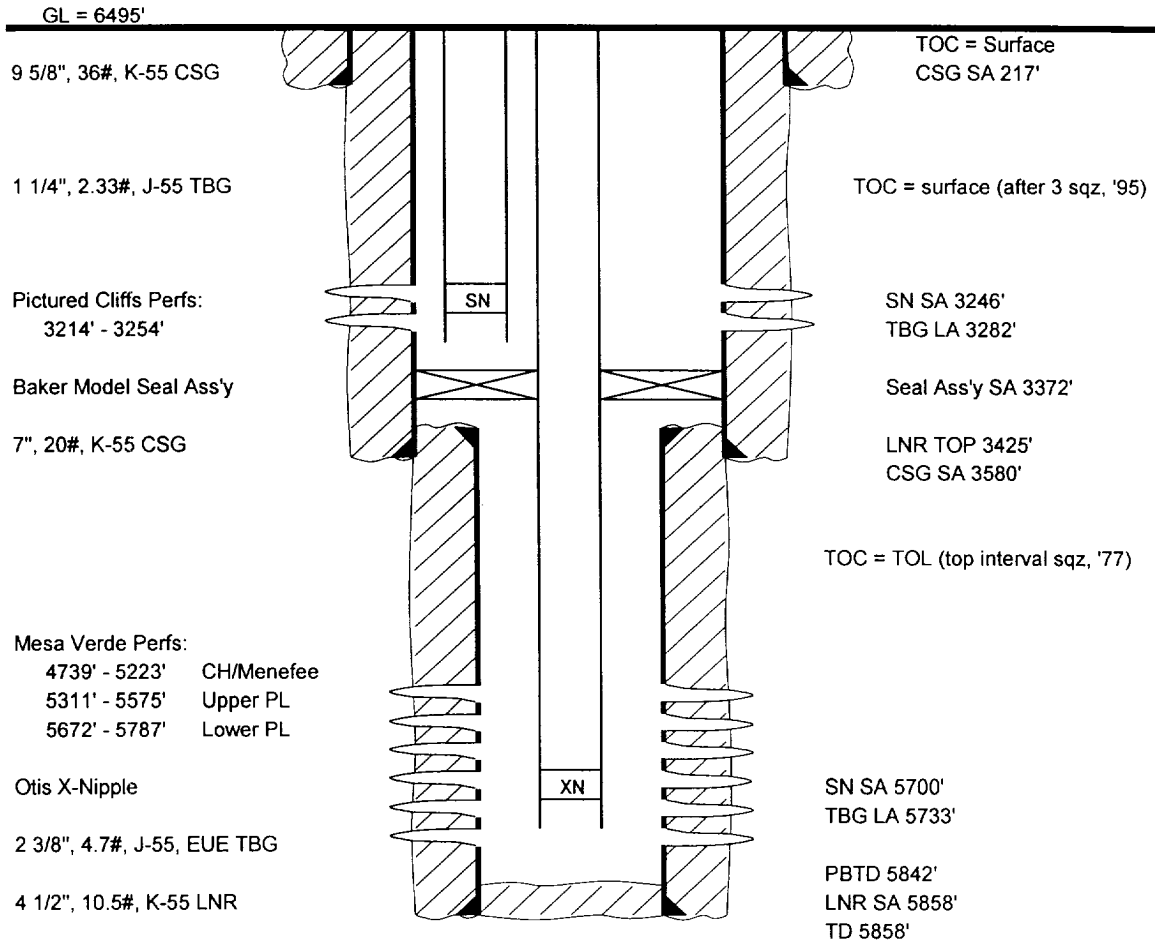

Updated: DRA 11/28/2001