

G-06-14

Form 3180-3  
(July 1992)

UNITED STATES  
DEPARTMENT OF THE INTERIOR  
BUREAU OF LAND MANAGEMENT

OCD-HOBBS  
SUBMIT IN TRIPLICATE\*

FORM APPROVED  
OMB NO. 1004-0136  
Expires: February 28, 1995

(Other instructions on reverse side)

5. LEASE DESIGNATION AND SERIAL NO.  
NM-03622

6. IF INDIAN, ALLOTTEE OR TRIBE NAME

APPLICATION FOR PERMIT TO DRILL OR DEEPEEN

1a. TYPE OF WORK  
 DRILL  DEEPEEN

1b. TYPE OF WELL  
 OIL WELL  GAS WELL  SINGLE ZONE  MULTIPLE ZONE

7. UNIT AGREEMENT NAME

2. NAME OF OPERATOR  
Cimarex Energy Co of Colorado  
Gray Petroleum Management Co. *(162683)*

8. FARM OR LEASE NAME, WELL NO. *(35708)*  
Scout 18 Federal No. 1

3. ADDRESS AND TELEPHONE NO.  
P.O. Box 140907; Irving TX 75014; 972-401-3111

9. API WELL NO.  
30-025- 37890

4. LOCATION OF WELL (Report location clearly and in accordance with any State requirements.)  
1800' FSL & 410' FWL

10. FIELD AND POOL, OR WILDCAT  
Tonto; 7 Rivers

11. SEC. T., R., M., BLOCK AND SURVEY OR AREA  
18-19S-34E

14. DISTANCE IN MILES AND DIRECTION FROM NEAREST TOWN OR POST OFFICE\*  
33 miles West of Hobbs, NM

12. COUNTY OR PARISH  
Lea

13. STATE  
NM

15. DISTANCE FROM PROPOSED LOCATION TO NEAREST PROPERTY OR LEASE LINE, T.O  
(Also to nearest drlg. unit line, if any) 410'

16. NO. OF ACRES IN LEASE

17. NO. OF ACRES ASSIGNED TO THIS WELL  
40

18. DISTANCE FROM PROPOSED LOCATION TO NEAREST WELL, DRILLING COMPLETED, OR APPLIED FOR, ON THIS LEASE, FT.  
N/A

19. PROPOSED DEPTH  
5000'

20. ROTARY OR CABLE TOOLS  
Rotary

21. ELEVATIONS (Show whether DF, RT, GR, etc.)  
3704' GR  
Cannon Controlled Water Depth

22. APPROX. DATE WORK WILL START\*  
04-30-06

23. PROPOSED CASING AND CEMENTING PROGRAM

SIZE OF HOLE	GRADE, SIZE OF CASING	WEIGHT PER FOOT	SETTING DEPTH	QUANTITY OF CEMENT
12-1/4"	J-55 8-5/8" ST&C	24#	425'	400 sx Lite/C circ surf
7-7/8"	J-55 5-1/2" ST&C	15.5#	5000'	1000sx Lite/C circ surf

The proposed well will be drilled to a depth of 5000' and completed as a Tonto; Seven Rivers producer.

From the base of the surface pipe through the running of production casing, the well will be equipped with a 3000 - psi BOP system.

APPROVAL SUBJECT TO  
GENERAL REQUIREMENTS AND  
SPECIAL STIPULATIONS  
ATTACHED

IN ABOVE SPACE, DESCRIBE PROPOSED PROGRAM: If proposal is to deepen, give data on present productive zone and proposed new productive zone. If proposal is to drill or deepen directionally, give pertinent data on subsurface locations and measured and true vertical depths. Give blowout preventer program, if any.

24. SIGNED Zeno Farris TITLE Mgr. Ops. Admin DATE 04-06-06

(This space for Federal or State office use)  
PERMIT No. \_\_\_\_\_ APPROVAL DATE \_\_\_\_\_

Application approval does not warrant or certify that the applicant holds legal or equitable title to those rights in the subject lease which would entitle the applicant to conduct operations thereon.  
CONDITIONS OF APPROVAL, IF ANY:  
APPROVED BY /s/ Tony J. Herrell TITLE FIELD MANAGER DATE MAY 19 2006

\*See Instructions On Reverse Side

Title 18 U.S.C. Section 1001, makes it a crime for any person knowingly and willfully to make to any department or agency of the United States any false, fictitious or fraudulent statements or representations as to any matter within its jurisdiction.

APPROVAL FOR 1 YEAR

*KZ*

Witness Surface Casing

UNITED STATES  
DEPARTMENT OF THE INTERIOR  
BUREAU OF LAND MANAGEMENT

FORM APPROVED  
OMB No. 1004-0137  
Expires March 31, 2007

**SUNDRY NOTICES AND REPORTS ON WELLS**  
*Do not use this form for proposals to drill or to re-enter an abandoned well. Use Form 3160-3 (APD) for such proposals.*

5. Lease Serial No.  
NM-03622

6. If Indian, Allottee or Tribe Name

7. If Unit or CA/Agreement, Name and/or No.

8. Well Name and No.  
SCOUT 18 FEDERAL #001

9. API Well No.  
30-025-

10. Field and Pool, or Exploratory Area  
TONTON; 7 RIVERS

11. County or Parish, State  
Lea County, NM

**SUBMIT IN TRIPLICATE- Other instructions on reverse side.**

1. Type of Well  
 Oil Well     Gas Well     Other

2. Name of Operator  
Cimarex Energy Co. of Colorado

3a. Address  
PO Box 140907; Irving, TX 75014-0907

3b. Phone No. (include area code)  
972-401-3111

4. Location of Well (Footage, Sec., T., R., M., or Survey Description)  
1800' FSL & 410' FWL  
3-18-19S-34E

**12. CHECK APPROPRIATE BOX(ES) TO INDICATE NATURE OF NOTICE, REPORT, OR OTHER DATA**

TYPE OF SUBMISSION	TYPE OF ACTION			
<input checked="" type="checkbox"/> Notice of Intent	<input type="checkbox"/> Acidize	<input type="checkbox"/> Deepen	<input type="checkbox"/> Production (Start/Resume)	<input type="checkbox"/> Water Shut-Off
<input type="checkbox"/> Subsequent Report	<input type="checkbox"/> Alter Casing	<input type="checkbox"/> Fracture Treat	<input type="checkbox"/> Reclamation	<input type="checkbox"/> Well Integrity
<input type="checkbox"/> Final Abandonment Notice	<input type="checkbox"/> Casing Repair	<input type="checkbox"/> New Construction	<input type="checkbox"/> Recomplete	<input checked="" type="checkbox"/> Other <u>Name change</u>
	<input type="checkbox"/> Change Plans	<input type="checkbox"/> Plug and Abandon	<input type="checkbox"/> Temporarily Abandon	
	<input type="checkbox"/> Convert to Injection	<input type="checkbox"/> Plug Back	<input type="checkbox"/> Water Disposal	

13. Describe Proposed or Completed Operation (clearly state all pertinent details, including estimated starting date of any proposed work and approximate duration thereof. If the proposal is to deepen directionally or recomplete horizontally, give subsurface locations and measured and true vertical depths of all pertinent markers and zones. Attach the Bond under which the work will be performed or provide the Bond No. on file with BLM/BIA. Required subsequent reports shall be filed within 30 days following completion of the involved operations. If the operation results in a multiple completion or recompletion in a new interval, a Form 3160-4 shall be filed once testing has been completed. Final abandonment Notices shall be filed only after all requirements, including reclamation, have been completed, and the operator has determined that the site is ready for final inspection.

Gruy Petroleum Management Co. has changed its name to Cimarex Energy Co. of Colorado. In this regard, effective 5-1-06, the subject lease will be operated by Cimarex Energy Co. of Colorado.

Cimarex Energy of Co. of Colorado accepts all responsibility under the terms and conditions of said lease. Bond coverage in the amount of \$25,000 is provided under BLM Bond No. NM 2575 in favor of the Bureau of Land Management, U.S. Department of Interior.

14. I hereby certify that the foregoing is true and correct  
Name (Printed/Typed)

Zeno Farris	Title Manager Operations Administration
Signature <i>Zeno Farris</i>	Date May 1, 2006

**THIS SPACE FOR FEDERAL OR STATE OFFICE USE**

Approved by	Title	Date
Conditions of approval, if any, are attached. Approval of this notice does not warrant or certify that the applicant holds legal or equitable title to those rights in the subject lease which would entitle the applicant to conduct operations thereon.	Office	
Title 18 U.S.C Section 1001 and Title 43 U.S.C. section 1212, make it a crime for any person knowingly and willfully to make to any department or agency of the United States any false, fictitious, or fraudulent statements or representations as to any matter within its jurisdiction.		

## Gruy Petroleum Management Co.

5215 North O'Connor Blvd. • Suite 1500 • Irving, TX 75039 • (972) 401-3111 • Fax (972) 443-6486  
Mailing Address: P.O. Box 140907 • Irving, TX 75014-0907  
*A wholly-owned subsidiary of Cimarex Energy Co., a NYSE Listed Company, "XEC"*



### STATEMENT ACCEPTING RESPONSIBILITY FOR OPERATIONS

Bureau of Land Management  
620 E. Greene St.  
Carlsbad, New Mexico 88220  
Attn: Ms. Betty Hill

Gruy Petroleum Management Co. accepts all applicable terms, conditions, stipulations and restrictions concerning operations conducted on the leased land, or portion thereof, as described below:

Lease No.: NM-03622 – All Section 18-T19S-R34E

County: Lea County, New Mexico

Formation (S): Morrow

Bond Coverage: Statewide BLM Bond

BLM Bond File No.: NM 2575

Authorized Signature: Zeno Farris  
Representing Gruy Petroleum Management Co.

Name: Zeno Farris

Title: Manager, Operations Administration

Date: April 6, 2006



## Application to Drill

Gruy Petroleum Management Co.  
Scout 18 Federal No. 1  
Lot 3 Section 18  
T19S R34E Lea County, NM

In response to questions asked under Section II B of Bulletin NTL-6 the following information is provided for your consideration:

1 Location: 1800' FSL & 410' FWL

2 Elevation above sea level: GR 3704'

3 Geologic name of surface formation: Quaternary Alluvium Deposits

4 Drilling tools and associated equipment: Conventional rotary drilling rig using fluid as a circulating medium for solids removal.

5 Proposed drilling depth: 5000'

6 Estimated tops of geological markers:

Rustler	1575'
Yates	3365'
7 Rivers	3890'
Queen	4395'
Capitan	5000'

7 Possible mineral bearing formation:

7 Rivers	Oil
Queen	Oil

8 Casing program:

Hole Size	Interval	Casing OD	Weight	Thread	Collar	Grade
12-1/4"	0-425'	8-5/8"	24#	8-R	ST&C	J-55
7-7/8"	0-5000'	5-1/2"	15.5#	8-R	ST&C	J-55



## Application to Drill

Gruy Petroleum Management Co.  
 Scout 18 Federal No. 1  
 Lot 3 Section 18  
 T19S R34E Lea County, NM

9 Cementing & Setting Depth:

8-5/8"	Intermediate	Set 425' of 8-5/8" J-55 24# ST&C casing. Cement lead with 250 Sx. Of Lite Cement + additives, tail with 150 Sx. Of Class C + additives, circulate cement to surface.
5 1/2"	Production	Set 5000' of 5 1/2" J-55 17# ST&C casing. Cement with lead of 700 Sx. of Lite Cement + additives and tail of 300 Sx of Class C. Estimated top of cement surface.

10 Pressure control Equipment:

Exhibit "E". A series 900 3000PSI working pressure B.O.P. consisting of a double ram type preventor with a bag type annular preventor. BOP unit will be hydraulically operated. Exhibit "E-1" is a Choke manifold and closing unit. BOP will be nipped up on the 8 5/8" casing and will be operated at least once a day while drilling and the blind rams will be operated when out of hole during trips. Flo sensor, PVT, full opening stabbing valve and upper kelly cock will be utilized. No abnormal pressure or temperature is expected while drilling.

11 Proposed Mud Circulating System:

Depth	Mud Wt	Viscosity	Fluid Loss	Type Mud
0-425' <i>1614'</i>	8.6 - 8.9	29 - 36	NC	Fresh water spud mud add paper to control seepage and high viscosity sweeps to clean hole.
<i>1614'</i> 425' - 5000' <i>(JSS)</i>	10 - 10 - 3	29 - 38	NC	Fresh water spud mud to the top of the Rustler then switch to brine water add paper as needed to control seepage and add lime to control pH, Use high viscosity sweeps to clean hole.

Sufficient mud materials will be kept on location at all times in order to combat lost circulation, or unexpected kicks. In order to run DST's, open hole logs, and casing, the viscosity and water loss may have to be adjusted in order to meet these needs. Mud system monitoring equipment with derrick floor indicators and visual/audio alarms shall be installed and operative prior to drilling into the Wolfcamp formation. This equipment will remain in use until production casing is run and cemented.

*22, 23, 24, 25, 26*

*22, 23, 24, 25, 26*

## Application to Drill

Gruy Petroleum Management Co.  
Scout 18 Federal No. 1  
Lot 3 Section 18  
T19S R34E Lea County, NM

### 12 Testing, Logging and Coring Program:

- A. Open hole logs: Dual Laterolog, Side Wall Neutron, Density Gamma Ray Caliper from TD to 975'
- B. Run Gamma Ray, Neutron from 475' to surface.
- C. No DSTs, cores or Mud Logger are planned at this time.

### 13 Potential Hazards:

No abnormal pressures or temperatures are expected. The area has a potential H2S hazard. An H2S drilling plan is attached. Adequate flare lines will be installed off the mud / gas separator where gas may be flared safely. All personnel will be familiar with all aspects of safe operation of equipment being used. Estimated BHP 4000 PSI, estimated BHT 175.

### 14 Anticipated Starting Date and Duration of Operations:

Road and location construction will begin after BLM approval of APD. Anticipated spud date as soon as approved. Drilling expected to take 15-30 days. If production casing is run an additional 30 days will be required to complete and construct surface facilities.

### 15 Other Facets of Operations:

After running casing, cased hole gamma ray neutron collar logs will be run from total depth over possible pay intervals. The 7 Rivers pay will be perforated and stimulated. The well will be tested and potentialed as an oil well.

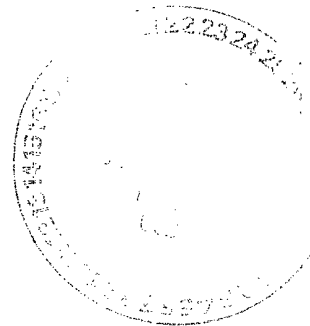

# Hydrogen Sulfide Drilling Operations Plan

Gruy Petroleum Management Co.  
Scout 18 Federal No. 1  
Lot 3 Section 18  
T19S R34E Lea County, NM

- 1 All Company and Contract personnel admitted on location must be trained by a qualified H2S safety instructor to the following:
  - A. Characteristics of H2S
  - B. Physical effects and hazards
  - C. Proper use of safety equipment and life support systems.
  - D. Principle and operation of H2S detectors, warning system and briefing
  - E. Evacuation procedure, routes and first aid.
  - F. Proper use of 30 minute pressure demand air pack.
  
- 2 H2S Detection and Alarm Systems
  - A. H2S detectors and audio alarm system to be located at bell nipple, end of flow line (mud pit) and on derrick floor or doghouse.
  
- 3 Windsock and/or wind streamers
  - A. Windsock at mudpit area should be high enough to be visible.
  - B. Windsock at briefing area should be high enough to be visible.
  
- 4 Condition Flags and Signs
  - A. Warning sign on access road to location.
  - B. Flags to be displayed on sign at entrance to location. Green flag, normal safe condition. Yellow flag indicates potential pressure and danger. Red flag, danger, H2S present in dangerous concentration. Only emergency personnel admitted to location.
  
- 5 Well control equipment
  - A. See exhibit "E"
  
- 6 Communication
  - A. While working under masks chalkboards will be used for communication.
  - B. Hand signals will be used where chalk board is inappropriate.
  - C. Two way radio will be used to communicate off location in case of emergency help is required. In most cases cellular telephones will be available at most drilling foremen's trailers or living quarters.
  
- 7 Drillstem Testing not anticipated.



## Hydrogen Sulfide Drilling Operations Plan

Gruy Petroleum Management Co.

Scout 18 Federal No. 1

Lot 3 Section 18

T19S R34E Lea County, NM

- 8 Drilling contractor supervisor will be required to be familiar with the effects H2S has on tubular goods and other mechanical equipment.
  
- 9 If H2S is encountered, mud system will be altered if necessary to maintain control of formation. A mud gas separator will be brought into service along with H2S scavengers if necessary.





## Surface Use Plan

Gruy Petroleum Management Co.  
Scout 18 Federal No. 1  
Lot 3 Section 18  
T19S R34E Lea County, NM

- 1 Existing Roads: Area maps, Exhibit "B" is a reproduction of Lea Co. General Highway Map. Exhibit "C" is a reproduction of a USGS Topographic Map, showing existing roads and proposed roads. All existing roads will be maintained in a condition equal to or better than current conditions. Any new roads will be constructed to BLM specifications.
  - A. Exhibit "A" shows the proposed well site as staked.
  - B. From the junction of US HWY 62/180 and Smith Ranch Road, go North for 2.0 miles; thence East for 2.0 miles; thence North for 1.2 miles to proposed lease road to the Pipeline Deep Unit No. 6.
  - C. Construct power lines and lay pipelines that will be necessary to produce this lease along road R-O-W.
- 2 PLANNED ACCESS ROADS: 1827' of access road will be constructed on lease.
  - A. The access road will be crowned and ditched to a 12' 00" wide travel surface with a 40' right-of-way.
  - B. Gradient on all roads will be less than 5.00%.
  - C. No turnouts will be necessary.
  - D. If needed road will be surfaced with a minimum of 4" of caliche. This material will be obtained from a
  - E. Ceterline for the new access road has been flagged. Earthwork will be required by field conditions.
  - F. Culverts in the access road will not be used. The road will be constructed to utilize low water crossings for drainage as required by the topography
- 3 LOCATION OF EXISTING WELLS IN A ONE-MILE RADIUS EXHIBIT "A"
  - A. Water wells - None known
  - B. Disposal wells - None known
  - C. Drilling wells - None known
  - D. Producing wells - As shown on Exhibit "A"
  - E. Abandoned wells - As shown on Exhibit "A"



## Surface Use Plan

Gruy Petroleum Management Co.  
Scout 18 Federal No. 1  
Lot 3 Section 18  
T19S R34E Lea County, NM

- 4 If, on completion, this well is a producer, Gruy Petroleum Management Co. will furnish maps and/or plats showing on-site facilities or off-site facilities if needed. This will be accompanied by a Sundry Notice.

5 LOCATION AND TYPE OF WATER SUPPLY:

Water will be purchased locally from a commercial source and trucked over the access roads or piped in flexible lines laid on top of the ground.

6 SOURCE OF CONSTRUCTION MATERIAL:

If possible construction will be obtained from the excavation of drill site, if additional material is needed it will be purchased from a local source and transported over the access route as shown on Exhibit "C".

7 METHODS OF HANDLING WASTE MATERIAL:

- A. Drill cuttings will be disposed of in the reserve pit.
- B. All trash, junk and other waste material will be contained in trash cages or bins to prevent scattering. When the job is completed all contents will be removed and disposed of in a approved sanitary land fill.
- C. Salts remaining after completion of well will be picked up by supplier including broken sacks.
- D. Sewage from living quarters will drain into holding tanks and be cleaned out periodically. A Porta-John will be provided for the rig crews. This equipment will be properly maintained during the drilling operations and removed upon completion of the well.
- E. Remaining drilling fluids will be allowed to evaporate in the reserve pit until the pit is dry enough for breaking out. In the event that drilling fluids do not evaporate in a reasonable time they will be hauled off by transports and be disposed of at a state approved disposal facility. Later pits will be broken out to speed drying. Water produced during testing will be put in reserve pits. Any oil or condensate produced will be stored in test tanks until sold and hauled from the site.



8 ANCILLARY FACILITIES:

- A. No camps or airstrips to be constructed.

## Surface Use Plan

Gruy Petroleum Management Co.  
Scout 18 Federal No. 1  
Lot 3 Section 18  
T19S R34E Lea County, NM

### 9 WELL SITE LAYOUT

- A. Exhibit "D" shows location and rig layout.
- B. This exhibit indicates proposed location of reserve and trash pits; and living facilities.
- C. Mud pits in the active circulating system will be steel pits and the reserve pit is proposed to be unlined, unless subsurface condition encountered during pit construction indicate that lining is needed for lateral containment of fluids.
- D. If needed, the reserve pit is to be lined with PVC or polyethylene line. The pit liner will be 12 mils thick. Pit liner will extend a minimum, 2'00" over the reserve pits dikes where the liner will be anchored down.
- E. The reserve pit will be fenced on three sides with four strands of barbed wire during drilling and completion phases. The fourth side will be fenced after all drilling operations have ceased. If the well is a producer, the reserve pit fence will be torn down. The reserve pit and those areas of the location not essential to production facilities will be reclaimed and seeded per BLM requirements.

### 10 PLANS FOR RESTORATION OF SURFACE

Rehabilitation of the location and reserve pit will start in a timely manner after all drilling operations cease. The type of reclamation will depend on whether the well is a producer or a dry hole.

However, in either event, the reserve pit will be allowed to dry properly, and fluid removed and disposed of in accordance with Article 7.B as previously noted. The pit area will then be leveled and contoured to conform to the original and surrounding area. Drainage systems, if any, will be reshaped to the original configuration with provisions made to alleviate erosion. These may need to be modified in certain circumstances to prevent inundation of the location's pad and surface facilities. After the area has been shaped and contoured, topsoil from the spoil pile will be placed over the disturbed area to the extent possible. Revegetation procedures will comply with BLM standards.

If the well is a dry hole, the pad and road area will be recontoured to match the existing terrain. Topsoil will be spread to the extent possible. Revegetation will comply with BLM standards.

Should the well be a producer, the previously noted procedures will apply to those areas which are not required for production facilities.

**Surface Use Plan**

Gruy Petroleum Management Co.  
Scout 18 Federal No. 1  
Lot 3 Section 18  
T19S R34E Lea County, NM

11 OTHER INFORMATION:

- A. Topography consists of a sloping plane with loose tan sands. Vegetation is mainly yucca, mesquite and shin oak.
  
- B. The wellsite is on surface owned by The United States Department of the Interior, Bureau of Land Management. The land is used mainly for farming, cattle ranching, recreational use, and oil and gas production.
  
- C. An Archaeological survey will be conducted on the location and proposed roads, and this report will be filed with the Bureau of Land Management in the Carlsbad BLM office.
  
- D. There are no known dwellings within 1 1/2 mile of this location.

12 OPERATORS REPRESENTATIVE:

Gruy Petroleum Management Company  
P.O. Box 140907  
Irving, TX 75014  
Office Phone: (972) 443-6489  
Zeno Farris

13 **CERTIFICATION:** I hereby certify that I, or persons under my direct supervision, have inspected the proposed drill site and access route; that I am familiar with the conditions which currently exist; that the statements made in this plan are to the best of my knowledge, true and correct; and that the work associated with the operations proposed herein will be performed by Gruy Petroleum Management Company and/or its contractors/subcontractors and is in conformity with this plan and the terms and conditions under which it is approved. This statement is subject to the provision of U.S.C. 1001 for the filing of a false statement.

NAME: Zeno Farris

DATE: 4/6/2006

TITLE: Manager, Operations Administration



DISTRICT I  
1625 N. French Dr., Hobbs, NM 88240

DISTRICT II  
811 South First, Artesia, NM 88210

DISTRICT III  
1000 Rio Brazos Rd., Aztec, NM 87410

DISTRICT IV  
2040 South Pacheco, Santa Fe, NM 87505

State of New Mexico  
Energy, Minerals and Natural Resources Department

Form C-102  
Revised March 17, 1999

Submit to Appropriate District Office  
State Lease - 4 Copies  
Fee Lease - 3 Copies

**OIL CONSERVATION DIVISION**  
2040 South Pacheco  
Santa Fe, New Mexico 87504-2088

AMENDED REPORT

**WELL LOCATION AND ACREAGE DEDICATION PLAT**

API Number <b>30-025-37890</b>	Pool Code <b>59470</b>	Pool Name Tonto; 7 Rivers
Property Code <b>35208</b>	Property Name SCOUT "18" FEDERAL	Well Number 1
OCRID No. 162683	Operator Name <b>Cimarex Energy Co of Colorado</b> <del>GRUY PETROLEUM MANAGEMENT COMPANY</del>	Elevation 3704'

**Surface Location**

UL or lot No.	Section	Township	Range	Lot Idn	Feet from the	North/South line	Feet from the	East/West line	County
LOT 3	18	19 S	34 E		1800	SOUTH	410	WEST	LEA

**Bottom Hole Location if Different From Surface**

UL or lot No.	Section	Township	Range	Lot Idn	Feet from the	North/South line	Feet from the	East/West line	County

Dedicated Acres	Joint or Infill	Consolidation Code	Order No.
40	N		

NO ALLOWABLE WILL BE ASSIGNED TO THIS COMPLETION UNTIL ALL INTERESTS HAVE BEEN CONSOLIDATED OR A NON-STANDARD UNIT HAS BEEN APPROVED BY THE DIVISION

<p>LOT 1 - 38.77 AC.</p> <p>LOT 2 - 38.99 AC.</p> <p>Scout 18 Fed #1</p> <p>LOT 3 - 39.21 AC.</p> <p>3705.1' - 3714.7'</p> <p>3702.5' - 3710.2'</p> <p>1800'</p> <p>LOT 4 - 39.43 AC.</p> <p><b>NM-03622</b></p> <p>Lot - N32°39'28.3" Long - W103°36'24.2" NMSPC - N 603827.598 E 764954.916</p>	<p><b>OPERATOR CERTIFICATION</b></p> <p>I hereby certify the the information contained herein is true and complete to the best of my knowledge and belief.</p> <p><i>Zeno Farris</i></p> <p>Signature Zeno Farris Printed Name Mgr Operations Admin Title April 6, 2006 Date</p> <p><b>SURVEYOR CERTIFICATION</b></p> <p>I hereby certify that the well location shown on this plat was plotted from field notes of actual surveys made by me or under my supervision and that the same is true and correct to the best of my belief.</p> <p>FEBRUARY 2006 Date Surveyed</p> <p><b>NEW MEXICO</b> Professional Surveyor 7877</p> <p>Certificate No. Gary L. Jones 7977</p> <p><b>BASIN SURVEYS</b></p>
---	--

DISTRICT I  
1625 N. French Dr., Hobbs, NM 88240

DISTRICT II  
811 South First, Artesia, NM 88210

DISTRICT III  
1000 Rio Brazos Rd., Aztec, NM 87410

DISTRICT IV  
2040 South Pacheco, Santa Fe, NM 87505

State of New Mexico  
Energy, Minerals and Natural Resources Department

Form C-102  
Revised March 17, 1999

Submit to Appropriate District Office  
State Lease - 4 Copies  
Fee Lease - 3 Copies

**OIL CONSERVATION DIVISION**

2040 South Pacheco  
Santa Fe, New Mexico 87504-2088

AMENDED REPORT

**WELL LOCATION AND ACREAGE DEDICATION PLAT**

API Number <b>30-025-37890</b>	Pool Code <b>59470</b>	Pool Name <b>Tonto; 7 Rivers</b>
Property Code <b>35108</b>	Property Name <b>SCOUT "18" FEDERAL</b>	Well Number <b>1</b>
OGRID No. <b>162683</b>	Operator Name <b>Cimarex Energy Co of Colorado</b> <del>GRUY PETROLEUM MANAGEMENT COMPANY</del>	Elevation <b>3704'</b>

**Surface Location**

UL or lot No.	Section	Township	Range	Lot Idn	Feet from the	North/South line	Feet from the	East/West line	County
LOT 3	18	19 S	34 E		1800	SOUTH	410	WEST	LEA

**Bottom Hole Location If Different From Surface**

UL or lot No.	Section	Township	Range	Lot Idn	Feet from the	North/South line	Feet from the	East/West line	County

Dedicated Acres <b>40</b>	Joint or Infill <b>N</b>	Consolidation Code	Order No.
------------------------------	-----------------------------	--------------------	-----------

NO ALLOWABLE WILL BE ASSIGNED TO THIS COMPLETION UNTIL ALL INTERESTS HAVE BEEN CONSOLIDATED OR A NON-STANDARD UNIT HAS BEEN APPROVED BY THE DIVISION

LOT 1 - 38.77 AC.				<p><b>OPERATOR CERTIFICATION</b></p> <p>I hereby certify the the information contained herein is true and complete to the best of my knowledge and belief.</p> <p><i>Zeno Farris</i></p> <p>Signature <b>Zeno Farris</b> Printed Name <b>Mgr Operations Admin</b> Title <b>April 6, 2006</b> Date</p> <p><b>SURVEYOR CERTIFICATION</b></p> <p>I hereby certify that the well location shown on this plat was plotted from field notes of actual surveys made by me or under my supervision, and that the same is true and correct to the best of my belief.</p> <p><b>FEBRUARY 21 2006</b> Date Surveyed</p> <p>Signature of Professional Surveyor <i>[Signature]</i></p> <p>No. <b>7977</b></p> <p>Certificate No. <b>Gary L. Jones 7977</b></p> <p><b>BASIN SURVEYS</b></p>
LOT 2 - 38.99 AC.				
Scout 18 Fed #1				
<p>LOT 3 - 39.21 AC.</p> <p>3705.1' 3714.7'</p> <p>3702.5' 3710.2'</p> <p>1800'</p> <p>Lat - N32°39'28.3" Long - W103°36'24.2" NMSPCE - N 603827.598 E 764954.916</p> <p><i>NM-03622</i></p>				
LOT 4 - 39.43 AC.				

SECTION 18, TOWNSHIP 19 SOUTH, RANGE 34 EAST, N.M.P.M.,  
LEA COUNTY, NEW MEXICO.

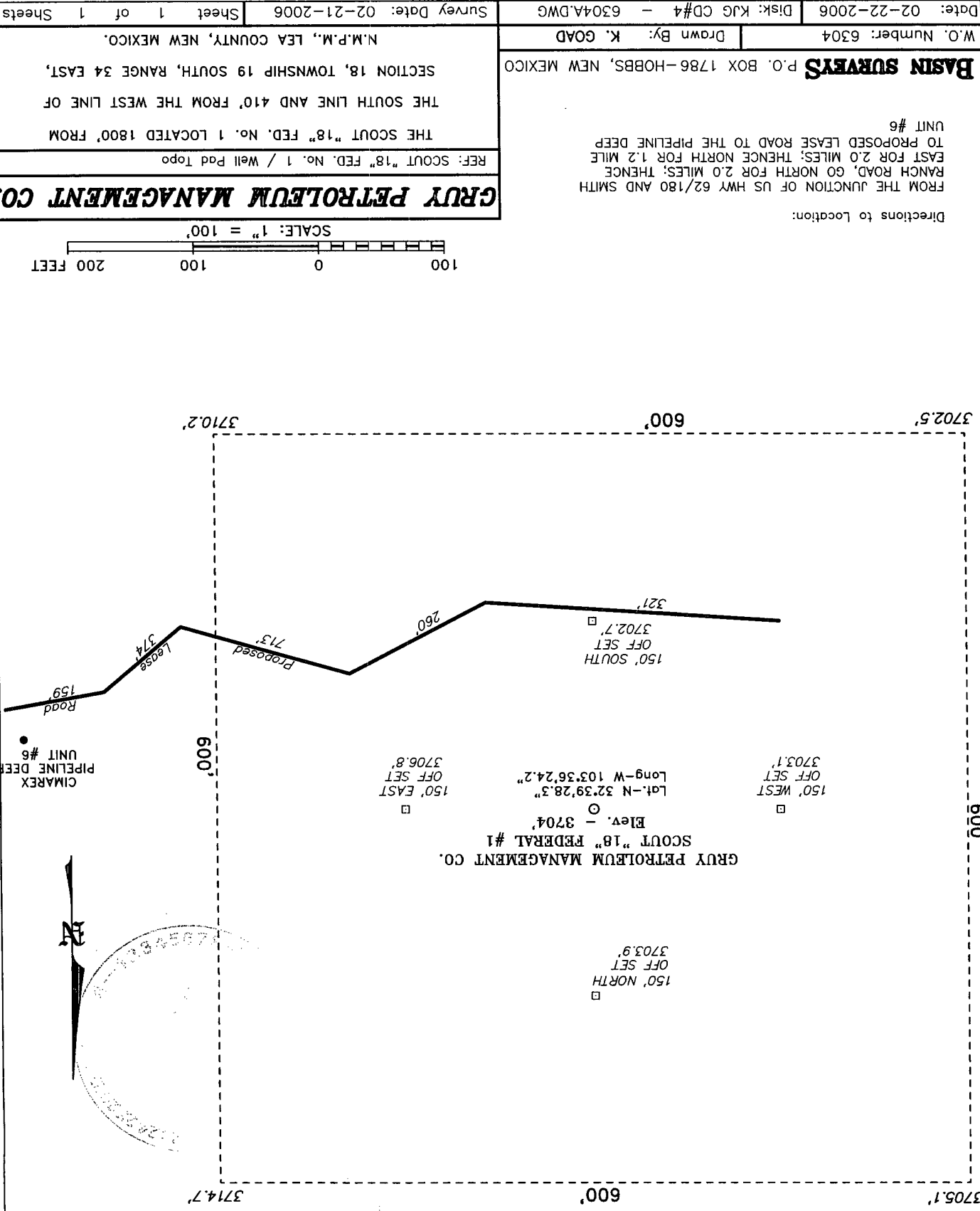

**GRUY PETROLEUM MANAGEMENT CO.**

REF: SCOUT "18" FED. No. 1 / Well Pad Topo

THE SCOUT "18" FED. No. 1 LOCATED 1800' FROM

THE SOUTH LINE AND 410' FROM THE WEST LINE OF

SECTION 18, TOWNSHIP 19 SOUTH, RANGE 34 EAST,

N.M.P.M., LEA COUNTY, NEW MEXICO.

Sheet 1 of 1 Sheets

Survey Date: 02-21-2006

**BASIN SURVEYS**

W.O. Number: 6304

Drawn By: K. GOAD

Date: 02-22-2006

Disk: KJG CD#4 - 6304A.DWG

Directions to Location:  
FROM THE JUNCTION OF US HWY 62/180 AND SMITH RANCH ROAD, GO NORTH FOR 2.0 MILES; THENCE EAST FOR 2.0 MILES; THENCE NORTH FOR 1.2 MILE TO PROPOSED LEASE ROAD TO THE PIPELINE DEEP UNIT #6

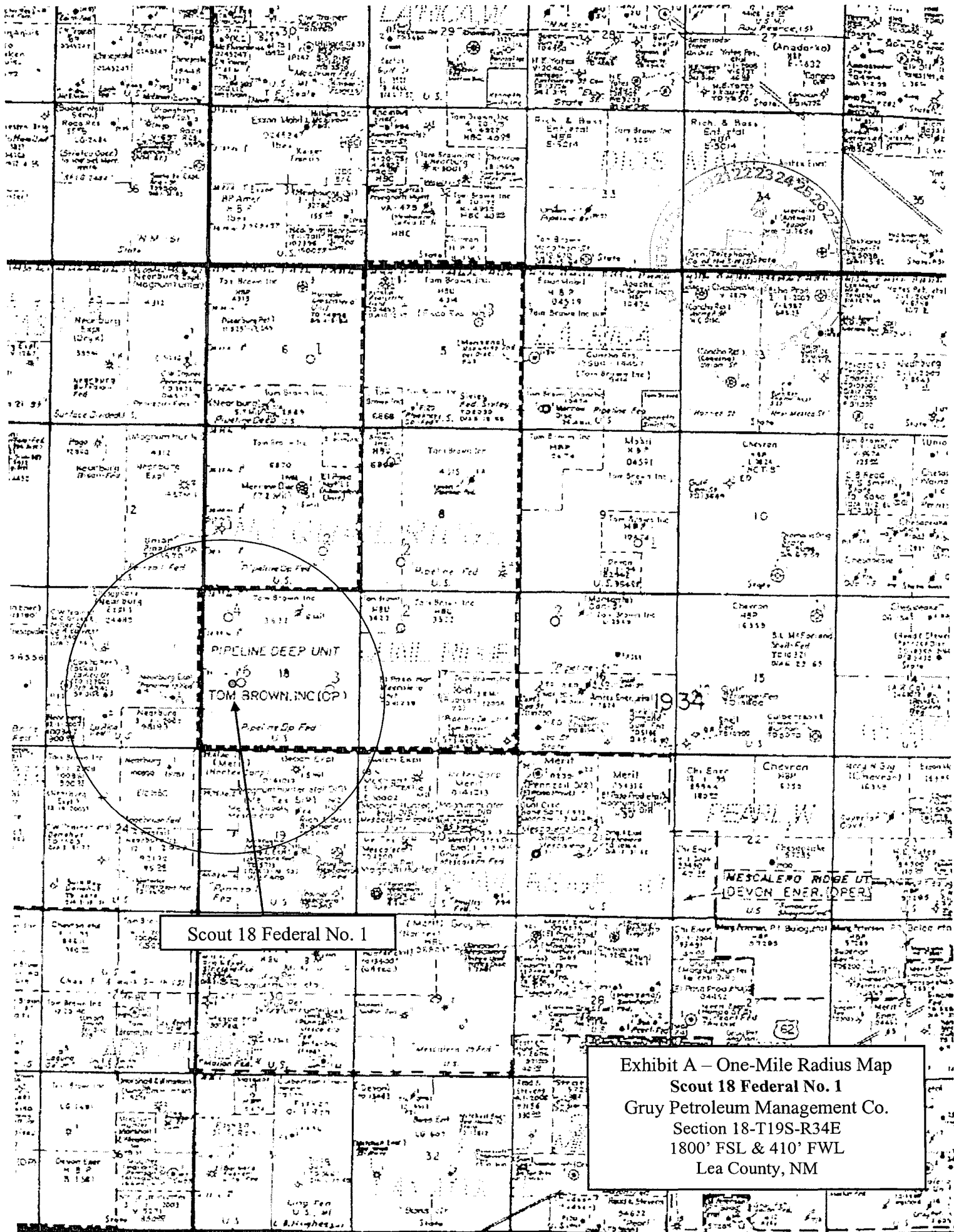

Scout 18 Federal No. 1

Exhibit A - One-Mile Radius Map  
 Scout 18 Federal No. 1  
 Gruy Petroleum Management Co.  
 Section 18-T19S-R34E  
 1800' FSL & 410' FWL  
 Lea County, NM



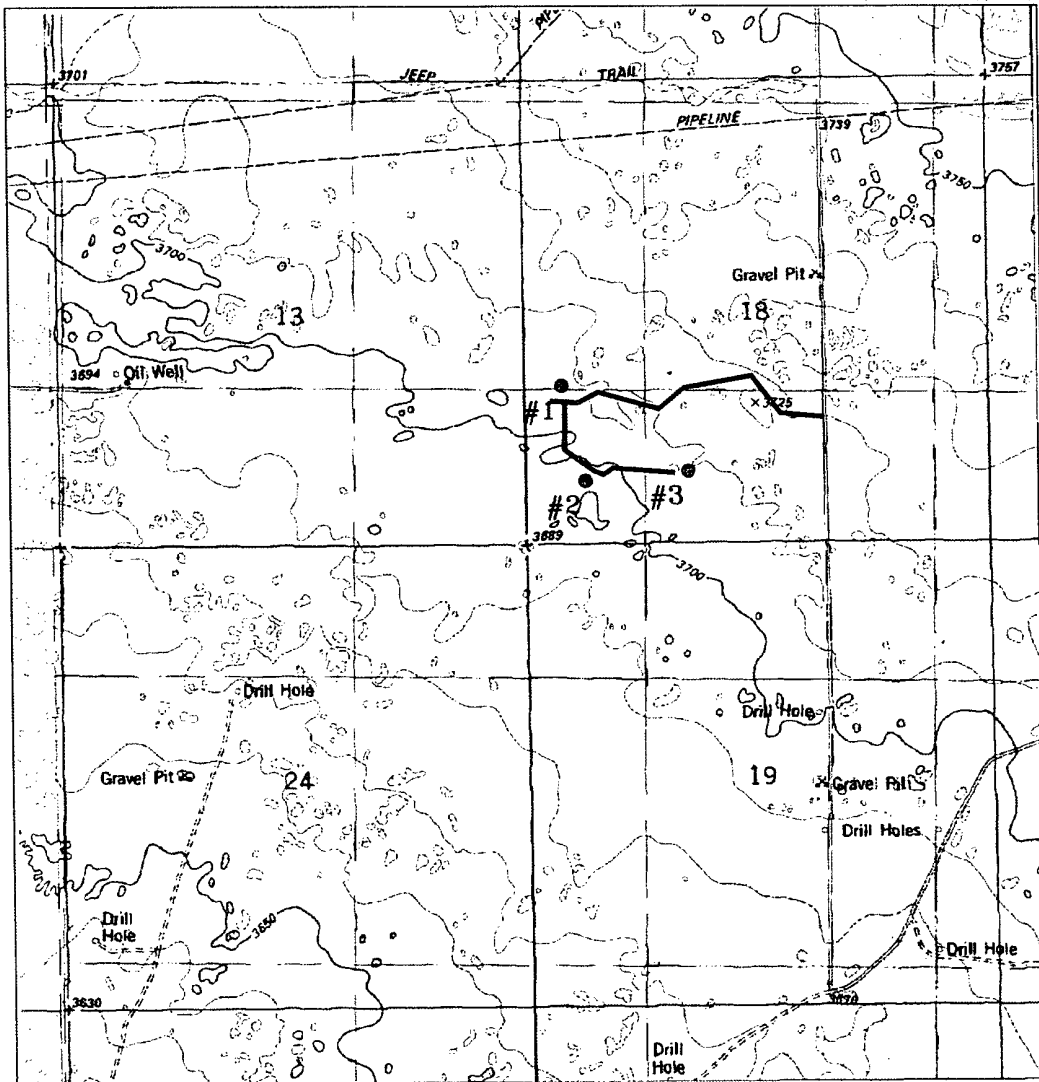
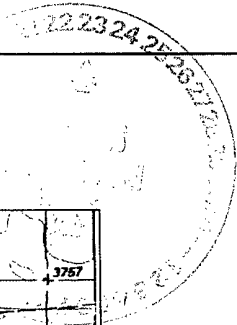

PROPOSED LEASE ROAD TO THE SCOUT "18" FEDERAL #1,2,&3  
 Section 18, Township 19 South, Range 34 East,  
 N.M.P.M., Lea County, New Mexico.

**basin surveys**  
 focused on excellence  
 in the oilfield

P.O. Box 1786  
 1120 N. West County Rd.  
 Hobbs, New Mexico 88241  
 (505) 393-7316 - Office  
 (505) 392-3074 - Fax  
 basinsurveys.com

W.O. Number: SCOUT ROAD - KJG
Survey Date: 03-29-2006
Scale: 1" = 2000'
Date: 04-05-2006

**GRUY PETROLEUM  
 MANAGEMENT CO.**

Exhibit B

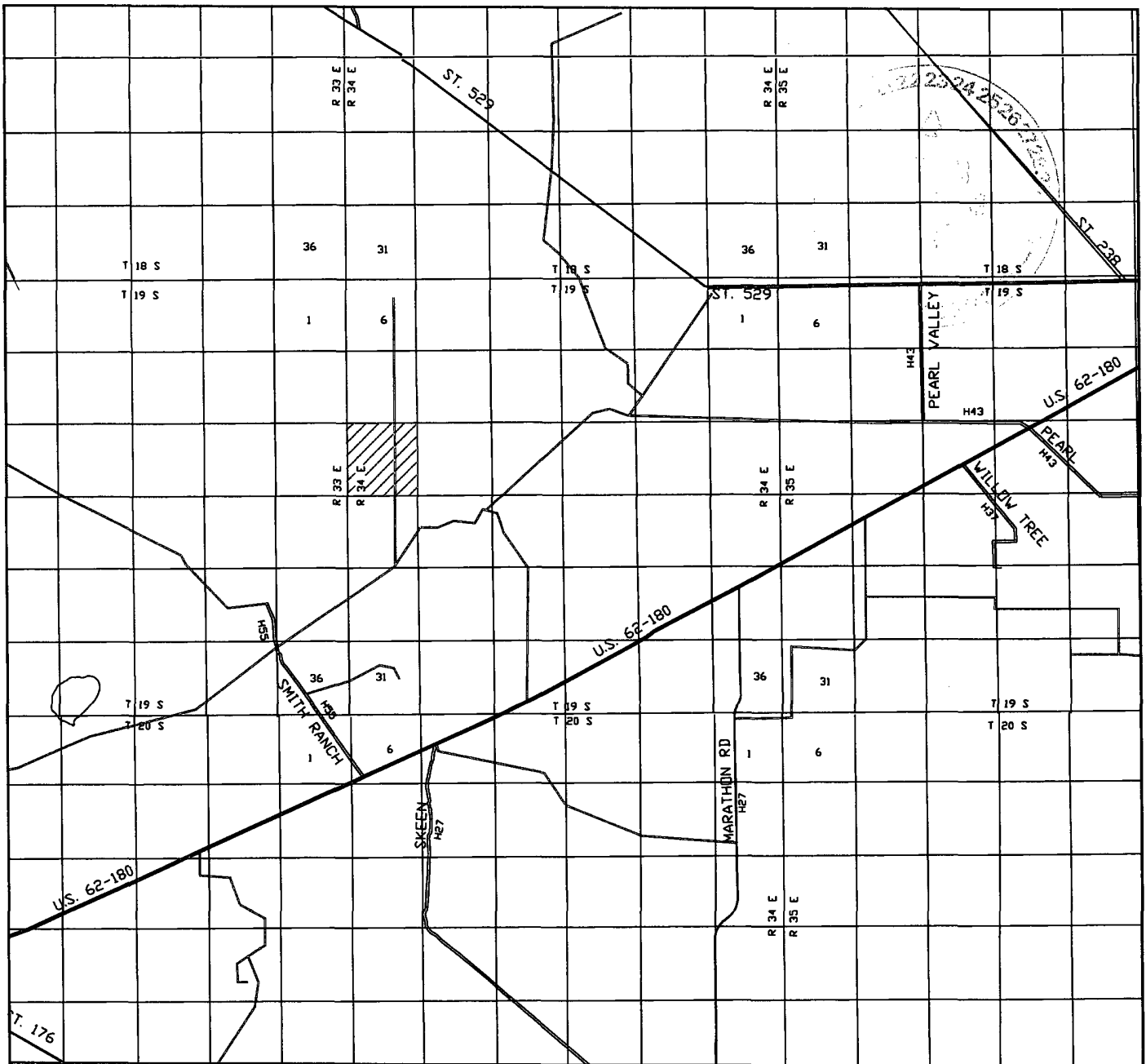

SCOUT "18" FEDERAL #1  
 Located at 1800' FSL AND 410' FWL  
 Section 18, Township 19 South, Range 34 East,  
 N.M.P.M., Lea County, New Mexico.

**basin surveys**  
 focused on excellence  
 in the oilfield

P.O. Box 1786  
 1120 N. West County Rd.  
 Hobbs, New Mexico 88241  
 (505) 393-7316 - Office  
 (505) 392-3074 - Fax  
 basinsurveys.com

W.O. Number: 6304AA - KJG CD#4
Survey Date: 02-21-2006
Scale: 1" = 2 MILES
Date: 02-22-2006

GRUY PETROLEUM  
 MANAGEMENT CO.

Exhibit C

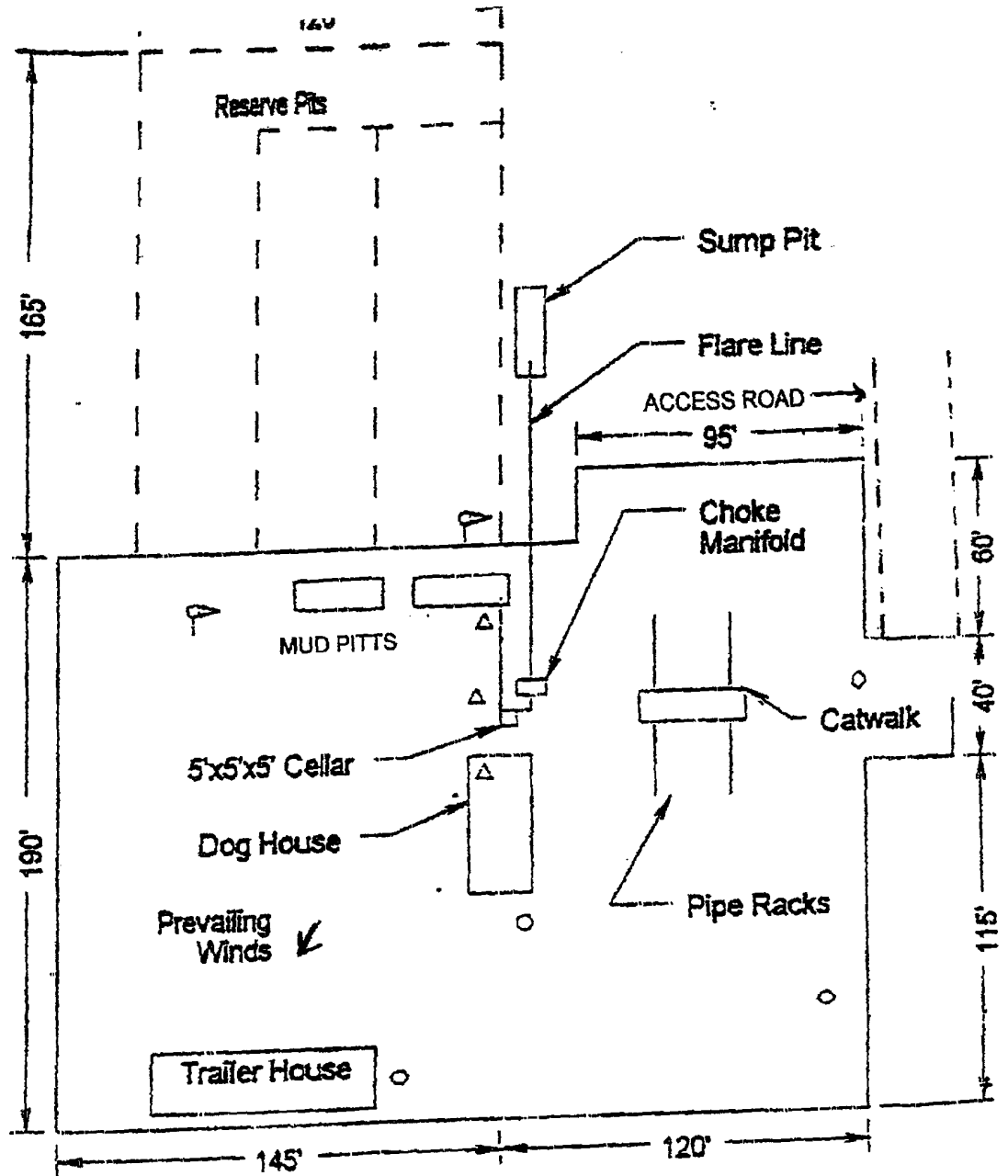

- ☐ Wind Direction Indicators (wind sock or streamers)
- △ H2S Monitors (alarms at bell nipple and shale shaker)
- Briefing Areas
- Remote BOP Closing Unit
- Sign and Condition Flags

Exhibit D - Rig Layout Plan  
 Scout 18 Federal No. 1  
 Gruy Petroleum Management Co.  
 Section 18-T19S-R34E  
 1800' FSL & 410' FWL  
 Lea County, NM

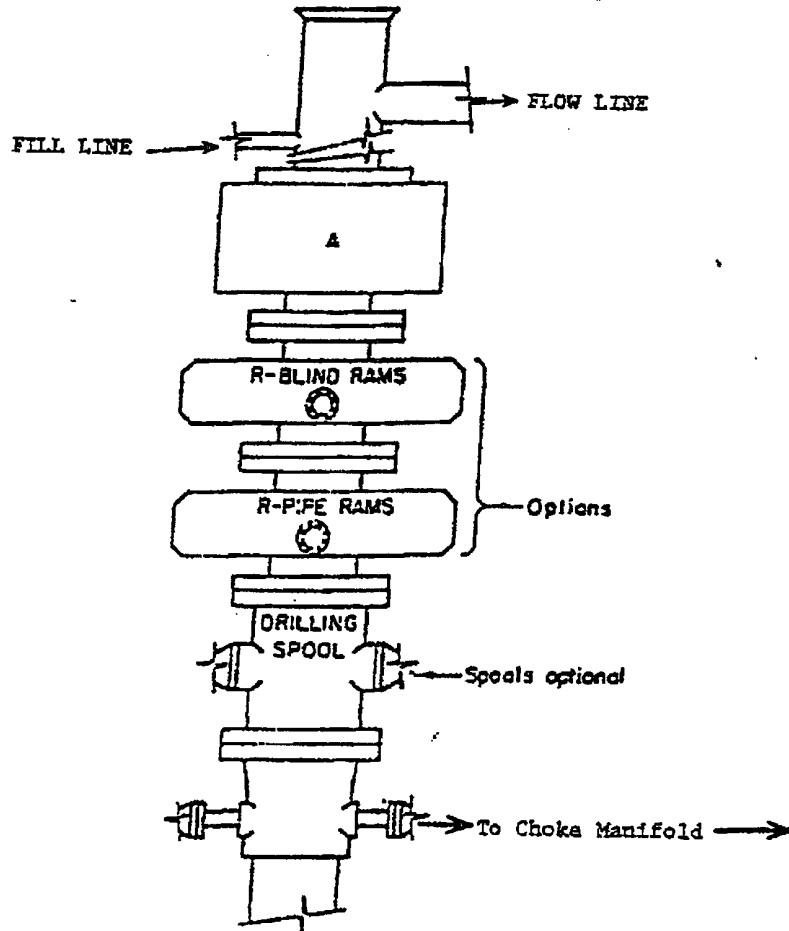

**ARRANGEMENT SBBA**

900 Series  
3000 PSI WP

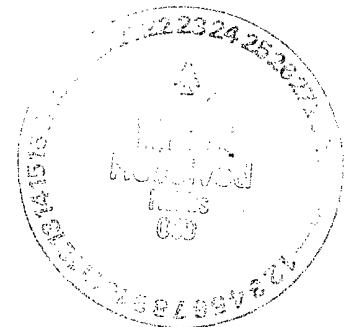
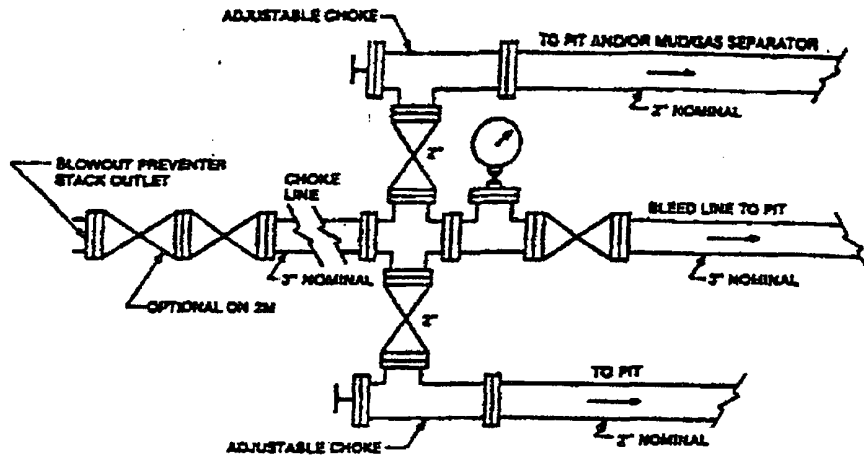

Exhibit E - Blowout Preventor  
**Scout 18 Federal No. 1**  
 Gruy Petroleum Management Co.  
 Section 18-T19S-R34E  
 1800' FSL & 410' FWL  
 Lea County, NM



Typical choke manifold assembly for 3M WP system

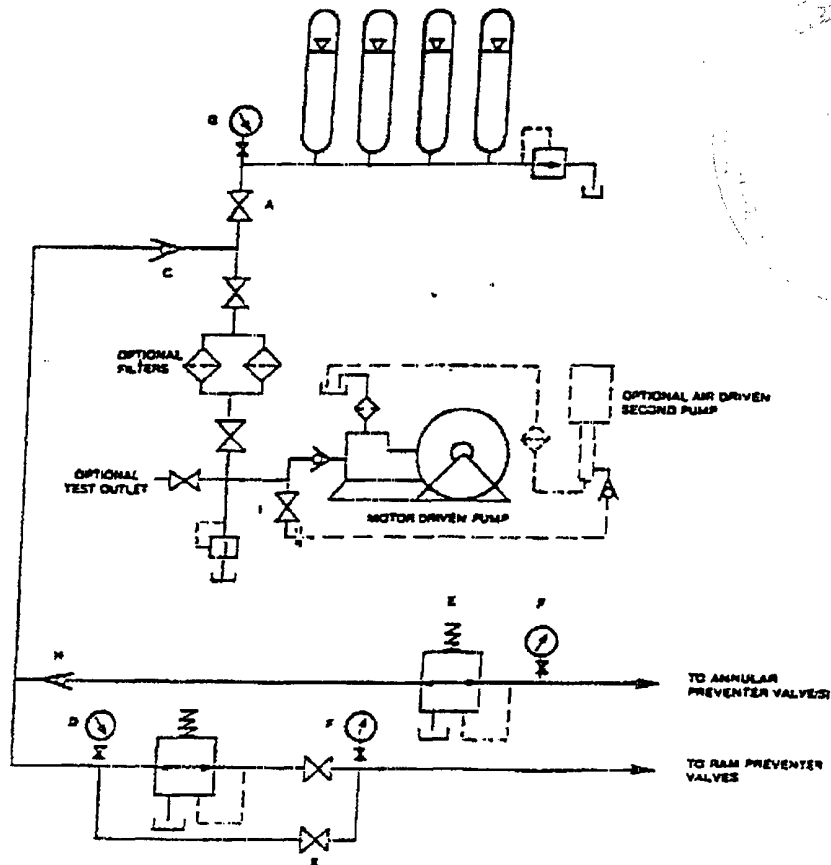

Exhibit E1 - Choke Manifold  
 Scout 18 Federal No. 1  
 Gruy Petroleum Management Co.  
 Section 18-T19S-R34E  
 1800' FSL & 410' FWL  
 Lea County, NM

District I  
1625 N. French Dr., Hobbs, NM 88240  
District II  
1301 W. Grand Avenue, Artesia, NM 88210  
District III  
1000 Rio Brazos Road, Aztec, NM 87410  
District IV  
1220 S. St. Francis Dr., Santa Fe, NM 87505

State of New Mexico  
Energy Minerals and Natural Resources  
Oil Conservation Division  
1220 South St. Francis Dr.  
Santa Fe, NM 87505

Form C-144  
March 12, 2004

For drilling and production facilities, submit to appropriate NMOCD District Office.  
For downstream facilities, submit to Santa Fe office

**Pit or Below-Grade Tank Registration or Closure**

Is pit or below-grade tank covered by a "general plan"? Yes  No

Type of action: Registration of a pit or below-grade tank  Closure of a pit or below-grade tank

Operator: Gruy Petroleum Management Co. Telephone: 972-443-6489 e-mail address: zfarris@cimarex.com  
Address: P.O. Box 140907, Irving, Tx 75014-0907  
Facility or well name: Scout 18 Federal No. 1 API #: 30-025-37890 U/L or Qtr/Qtr<sup>3</sup> Sec.18 T19S R34E  
County: Lea Latitude 323928.3 N Longitude 1033624.2 W NAD: 1927  1983  Surface Owner Federal  State  Private  Indian

Pit	Below-grade tank	
Type: Drilling <input checked="" type="checkbox"/> Production <input type="checkbox"/> Disposal <input type="checkbox"/> Workover <input type="checkbox"/> Emergency <input type="checkbox"/> Lined <input checked="" type="checkbox"/> Unlined <input type="checkbox"/> Liner type: Synthetic <input checked="" type="checkbox"/> Thickness <u>12</u> mil Clay <input type="checkbox"/> Volume <u>12000</u> bbl	Volume: _____ bbl Type of fluid: _____ Construction material: _____ Double-walled, with leak detection? Yes <input type="checkbox"/> If not, explain why not. _____	<b>RECEIVED</b> <b>APR 13 2006</b> <b>UUC-ARTESIA</b>
Depth to ground water (vertical distance from bottom of pit to seasonal high water elevation of ground water.)	Less than 50 feet (20 points) 50 feet or more, but less than 100 feet (10 points) <u>100 feet or more</u> (0 points)	
Wellhead protection area: (Less than 200 feet from a private domestic water source, or less than 1000 feet from all other water sources.)	Yes (20 points) <u>No</u> (0 points)	
Distance to surface water: (horizontal distance to all wetlands, playas, irrigation canals, ditches, and perennial and ephemeral watercourses.)	Less than 200 feet (20 points) 200 feet or more, but less than 1000 feet (10 points) <u>1000 feet or more</u> (0 points)	
<b>Ranking Score (Total Points)</b>		<b>0</b>

**If this is a pit closure:** (1) attach a diagram of the facility showing the pit's relationship to other equipment and tanks. (2) Indicate disposal location: onsite  offsite  If offsite, name of facility \_\_\_\_\_. (3) Attach a general description of remedial action taken including remediation start date and end date. (4) Groundwater encountered: No  Yes  If yes, show depth below ground surface \_\_\_\_\_ ft. and attach sample results. (5) Attach soil sample results and a diagram of sample locations and excavations.

I hereby certify that the information above is true and complete to the best of my knowledge and belief. I further certify that the above described pit or below-grade tank has been/will be constructed or closed according to NMOCD guidelines , a general permit , or an (attached) alternative OCD-approved plan .

Date: 04-06-06  
Printed Name/Title Zeno Farris Manager Operations Administration Signature: Zeno Farris

Your certification and NMOCD approval of this application/closure does not relieve the operator of liability should the contents of the pit or tank contaminate ground water or otherwise endanger public health or the environment. Nor does it relieve the operator of its responsibility for compliance with any other federal, state, or local laws and/or regulations.

Approval:

Date: MAY 26 2006  
Printed Name/Title PETROLEUM ENGINEER

Signature: [Signature]

MAY 26 2006

**Gruy Petroleum Management Co.**

5215 North O'Connor Blvd. ♦ Suite 1500 ♦ Irving, TX 75039 ♦ (972) 401-3111 ♦ Fax (972) 443-6486

Mailing Address: P.O. Box 140907 ♦ Irving, TX 75014-0907

*A subsidiary of Cimarex Energy Co. • A NYSE Listed Company • "XEC"*



April 6, 2006

Oil Conservation Division  
District I Office  
1625 North French Drive  
Hobbs, New Mexico 88240  
Attn: Ms. Donna Mull

Re: Statewide Rule 118  
Hydrogen Sulfide Gas Contingency Plan  
Proposed Scout 18 Federal No. 1 Well

Dear Ms. Mull:

In accordance with NMAC 19.15.3.118 C. (1) governing the determination of the hydrogen sulfide concentration in gaseous mixtures in each of its operations, Gruy Petroleum Management Co. does not anticipate that there will be enough H2S from the surface to the Morrow/Atoka formations to meet the OCD's minimum requirements for the submission of a contingency plan for the drilling and completion of the following test(s):

Scout 18 Federal No. 1  
3-18-19S-34E  
1800' FSL & 410' FWL  
Lea Co., NM

RECEIVED  
APR 14 2006  
OCD-ARTESIA

If anything further is needed regarding this issue, or if you have any questions, please feel free to contact the undersigned at 972-443-6489.

Yours truly,

Zeno Farris  
Manager Administration



 The sender of this message has requested a read receipt. [Click here to send a receipt.](#)

**Mull, Donna, EMNRD**

**From:** Phillips, Dorothy, EMNRD  
**To:** Mull, Donna, EMNRD  
**Cc:**  
**Subject:** RE: Financial Assurance Requirement  
**Attachments:**

**Sent:** Thu 5/25/2006 8:39 AM

Apache has to submit 3 one well bonds

All the rest have blanket bonds and do no appear on Jane's list.

---

**From:** Mull, Donna, EMNRD  
**Sent:** Thursday, May 25, 2006 8:23 AM  
**To:** Phillips, Dorothy, EMNRD  
**Cc:** Macquesten, Gail, EMNRD; Sanchez, Daniel J., EMNRD  
**Subject:** Financial Assurance Requirement

Dorothy,

Is the Financial Assurance Requirements for these Operators OK?

Cimarex Energy Co Of Colorado (162683)  
Marbob Energy Corp (14049)  
Apache Corp (873)  
Texland Petroleum-Hobbs LLC (113315)  
Pride Energy Co (151323)  
Platinum Exploration Inc (227103)  
Chaparral Energy LLC (4115)  
Range Operating New Mexico Inc (227588)

I have check the inactive list for each Operator.

Please let me know. Thanks and have a nice day. Donna