

ATS-07-83

Form 3160-3
(July 1992)

UNITED STATES **OCD-HOBBS** SUBMIT IN TRIPLICATE*
DEPARTMENT OF THE INTERIOR
BUREAU OF LAND MANAGEMENT
(Other instructions on reverse side)

FORM APPROVED
OMB NO. 1004-0136
Expires: February 28, 1995

APPLICATION FOR PERMIT TO DRILL OR DEEPEN

1a. TYPE OF WORK
 DRILL DEEPEN

1b. TYPE OF WELL
 OIL WELL GAS WELL SINGLE ZONE MULTIPLE ZONE

2. NAME OF OPERATOR
 Cimarex Energy Co. of Colorado

3. ADDRESS AND TELEPHONE NO.
 P.O. Box 140907; Irving TX 75014; 972-401-3111

4. LOCATION OF WELL (Report location clearly and in accordance with any State requirements.)
 2240' FNL & 750' FEL
Unit 4

14. DISTANCE IN MILES AND DIRECTION FROM NEAREST TOWN OR POST OFFICE*
 33 miles West of Hobbs, NM

15. DISTANCE FROM PROPOSED LOCATION TO NEAREST PROPERTY OR LEASE LINE, T.O.
 (Also to nearest drlg. unit line, if any) 400'

16. NO. OF ACRES IN LEASE
 1076.4

17. NO. OF ACRES ASSIGNED TO THIS WELL
 40

18. DISTANCE FROM PROPOSED LOCATION TO NEAREST WELL, DRILLING COMPLETED, OR APPLIED FOR, ON THIS LEASE, FT.
 N/A

19. PROPOSED DEPTH
 5000'

20. ROTARY OR CABLE TOOLS
 Rotary

21. ELEVATIONS (Show whether DF, RT, GR, etc.)
 3737' GR

22. APPROX. DATE WORK WILL START*
 01-15-06

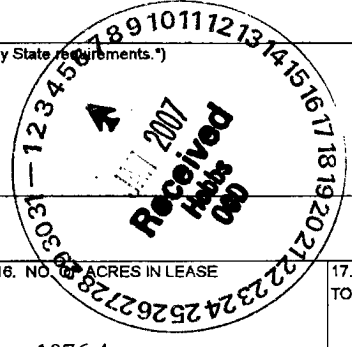

5. LEASE DESIGNATION AND SERIAL NO.
 NM-3622

6. IF INDIAN, ALLOTES OR TRIBE NAME

7. UNIT AGREEMENT NAME

8. FARM OR LEASE NAME, WELL NO. *<35708>*
 Scout 18 Federal No. 12

9. API WELL NO.
 30-025- *38246*

10. FIELD AND POOL, OR WILDCAT
 Tonto; 7 Rivers *<59470>*

11. SEC. T., R., M., BLOCK AND SURVEY OR AREA
 18-19S-34E

12. COUNTY OR PARISH
 Lea

13. STATE
 NM

23

PROPOSED CASING AND CEMENTING PROGRAM				
SIZE OF HOLE	GRADE, SIZE OF CASING	WEIGHT PER FOOT	SETTING DEPTH	QUANTITY OF CEMENT
12-1/4"	J-55 8-5/8" ST&C	24#	425' 900'	400 sx Lite/C circ surf
7-7/8"	J-55 5-1/2" ST&C	15.5#	5000'	2500 sx Lite/C circ surf

The proposed well will be drilled to a depth of 5000' and completed as a Tonto; Seven Rivers producer.
From the base of the surface pipe through the running of production casing, the well will be equipped with a 3000 - psi BOP system. **CAPITAN CONTROLLED WATER BASIN**

SEE ATTACHED FOR CONDITIONS OF APPROVAL

APPROVAL SUBJECT TO GENERAL REQUIREMENTS AND SPECIAL STIPULATIONS ATTACHED

IN ABOVE SPACE, DESCRIBE PROPOSED PROGRAM: If proposal is to deepen, give data on present productive zone and proposed new productive zone. If proposal is to drill or deepen directionally, give pertinent data on subsurface locations and measured and true vertical depths. Give blowout preventer program, if any.

24 SIGNED Zeno Farris TITLE Mgr. Ops. Admin DATE 11-17-06

(This space for Federal or State office use)

PERMIT No. _____ APPROVAL DATE _____

Application approval does not warrant or certify that the applicant holds legal or equitable title to those rights in the subject lease which would entitle the applicant to conduct operations thereon.

CONDITIONS OF APPROVAL, IF ANY: **FIELD MANAGER**

APPROVED BY Is/ James A. Amos TITLE _____ DATE JAN -3 2007

*See Instructions On Reverse Side
Title 18 U.S.C. Section 1001, makes it a crime for any person knowingly and willfully to make to any department or agency of the United States any false, fictitious or fraudulent statements or representations as to any matter within its jurisdiction.

APPROVAL FOR 1 YEAR



Cimarex Energy Co. of Colorado

5215 North O'Connor Blvd. • Suite 1500 • Irving, TX 75039 • (972) 401-3111 • Fax (972) 443-6486

Mailing Address: P.O. Box 140907 • Irving, TX 75014-0907

A wholly-owned subsidiary of Cimarex Energy Co., a NYSE Listed Company, "XEC"

STATEMENT ACCEPTING RESPONSIBILITY FOR OPERATIONS

Bureau of Land Management
620 E. Greene St.
Carlsbad, New Mexico 88220
Attn: Ms. Linda Denniston

Cimarex Energy Co. of Colorado accepts all applicable terms, conditions, stipulations and restrictions concerning operations conducted on the leased land, or portion thereof, as described below:

Lease No.: NM-3622 – SE/4NE/4 Section 18-T19S-R34E

County: Lea County, New Mexico

Formation (S): Morrow

Bond Coverage: Statewide BLM Bond

BLM Bond File No.: ~~NM2575~~ WB000011

Authorized Signature: Zeno Farris
Representing Cimarex Energy Co. of Colorado

Name: Zeno Farris

Title: Manager, Operations Administration

Date: November 17, 2006

Application to Drill

Cimarex Energy Co. of Colorado
Scout 18 Federal No. 12
Unit H Section 18
T19S R34E Lea County, NM

In response to questions asked under Section II B of Bulletin NTL-6 the following information is provided for your consideration:

1 Location: 2240' FNL & 750' FEL

2 Elevation above sea level: GR 3737'

3 Geologic name of surface formation: Quaternary Alluvium Deposits

4 Drilling tools and associated equipment: Conventional rotary drilling rig using fluid as a circulating medium for solids removal.

5 Proposed drilling depth: 5000'

6 Estimated tops of geological markers:

Rustler	1575'
Yates	3365'
7 Rivers	3890'
Queen	4395'
Capitan	5000'

7 Possible mineral bearing formation:

7 Rivers	Oil
Queen	Oil

8 Casing program:

Hole Size	Interval	Casing OD	Weight	Thread	Collar	Grade
11"	0-425' 100'	8-5/8"	24#	8-R	ST&C	J-55
7-7/8"	0-5000'	5-1/2"	17#	8-R	LT&C	J-55

Application to Drill

Cimarex Energy Co. of Colorado
 Scout 18 Federal No. 12
 Unit H Section 18
 T19S R34E Lea County, NM

9 Cementing & Setting Depth:

8-5/8"	Intermediate	Set ^{900'} 425' of 8-5/8" J-55 24# ST&C casing. Cement lead with 250 Sx. Of Lite Cement + additives, tail with 150 Sx. Of Class C + additives, circulate cement to surface.
5 1/2"	Production	Set 5000' of 5 1/2" J-55 17# ST&C casing. Cement with lead of 2100 Sx. of Lite Cement + additives and tail of 400 Sx of Class C. Estimated top of cement surface.

10 Pressure control Equipment:

Exhibit "E". A series 900 3000 PSI working pressure B.O.P. consisting of a double ram type preventor with a bag type annular preventor. BOP unit will be hydraulically operated. Exhibit "E-1" is a Choke manifold and closing unit. BOP will be nipped up on the 8 5/8" casing and will be operated at least once a day while drilling and the blind rams will be operated when out of hole during trips. Flo sensor, PVT, full opening stabbing valve and upper kelly cock will be utilized. No abnormal pressure or temperature is expected while drilling.

11 Proposed Mud Circulating System:

Depth	Mud Wt	Viscosity	Fluid Loss	Type Mud
0-425' <i>900'</i>	8.6 - 8.9	29 - 36	NC	Fresh water spud mud add paper to control seepage and high viscosity sweeps to clean hole. Top of Rustler,
425' - 5000'	10 - 10 - 3	29 - 38	NC	Fresh water spud mud to the top of the Rustler then switch to brine water add paper as needed to control seepage and add lime to control pH, Use high viscosity sweeps to clean hole.

Sufficient mud materials will be kept on location at all times in order to combat lost circulation, or unexpected kicks. In order to run DST's, open hole logs, and casing, the viscosity and water loss may have to be adjusted in order to meet these needs. Mud system monitoring equipment with derrick floor indicators and visual/audio alarms shall be installed and operative prior to drilling into the Wolfcamp formation. This equipment will remain in use until production casing is run and cemented.

Application to Drill

Cimarex Energy Co. of Colorado
Scout 18 Federal No. 12
Unit H Section 18
T19S R34E Lea County, NM

12 Testing, Logging and Coring Program:

- A. Open hole logs: Dual Laterolog, Side Wall Neutron, Density Gamma Ray Caliper from TD to 975'
- B. Run Gamma Ray, Neutron from 475' to surface.
- C. No DSTs, cores or Mud Logger are planned at this time.

13 Potential Hazards:

No abnormal pressures or temperatures are expected. The area has a potential H2S hazard. An H2S drilling plan is attached. Adequate flare lines will be installed off the mud / gas separator where gas may be flared safely. All personnel will be familiar with all aspects of safe operation of equipment being used. Estimated BHP 4000 PSI, estimated BHT 175.

14 Anticipated Starting Date and Duration of Operations:

Road and location construction will begin after BLM approval of APD. Anticipated spud date as soon as approved. Drilling expected to take 15-30 days. If production casing is run an additional 30 days will be required to complete and construct surface facilities.

15 Other Facets of Operations:

After running casing, cased hole gamma ray neutron collar logs will be run from total depth over possible pay intervals. The 7 Rivers pay will be perforated and stimulated. The well will be tested and potentialed as an oil well.

Hydrogen Sulfide Drilling Operations Plan

Cimarex Energy Co. of Colorado
Scout 18 Federal No. 12
Unit H Section 18
T19S R34E Lea County, NM

- 1 All Company and Contract personnel admitted on location must be trained by a qualified H2S safety instructor to the following:
 - A. Characteristics of H2S
 - B. Physical effects and hazards
 - C. Proper use of safety equipment and life support systems.
 - D. Principle and operation of H2S detectors, warning system and briefing
 - E. Evacuation procedure, routes and first aid.
 - F. Proper use of 30 minute pressure demand air pack.

- 2 H2S Detection and Alarm Systems
 - A. H2S detectors and audio alarm system to be located at bell nipple, end of flow line (mud pit) and on derrick floor or doghouse.

- 3 Windsock and/or wind streamers
 - A. Windsock at mudpit area should be high enough to be visible.
 - B. Windsock at briefing area should be high enough to be visible.

- 4 Condition Flags and Signs
 - A. Warning sign on access road to location.
 - B. Flags to be displayed on sign at entrance to location. Green flag, normal safe condition. Yellow flag indicates potential pressure and danger. Red flag, danger, H2S present in dangerous concentration. Only emergency personnel admitted to location.

- 5 Well control equipment
 - A. See exhibit "E"

- 6 Communication
 - A. While working under masks chalkboards will be used for communication.
 - B. Hand signals will be used where chalk board is inappropriate.
 - C. Two way radio will be used to communicate off location in case of emergency help is required. In most cases cellular telephones will be available at most drilling foremen's trailers or living quarters.

- 7 Drillstem Testing not anticipated.

Hydrogen Sulfide Drilling Operations Plan

Cimarex Energy Co. of Colorado

Scout 18 Federal No. 12

Unit H Section 18

T19S R34E Lea County, NM

- 8 Drilling contractor supervisor will be required to be familiar with the effects H₂S has on tubular goods and other mechanical equipment.

- 9 If H₂S is encountered, mud system will be altered if necessary to maintain control of formation. A mud gas separator will be brought into service along with H₂S scavengers if necessary.

Surface Use Plan

Cimarex Energy Co. of Colorado
Scout 18 Federal No. 12
Unit H Section 18
T19S R34E Lea County, NM

- 1 Existing Roads: Area maps, Exhibit "B" is a reproduction of Lea Co. General Highway Map. Exhibit "C" is a reproduction of a USGS Topographic Map, showing existing roads and proposed roads. All existing roads will be maintained in a condition equal to or better than current conditions. Any new roads will be constructed to BLM specifications.
 - A. Exhibit "A" shows the proposed well site as staked.
 - B. From the junction of US HWY 62/180 and Smith Ranch Road, go North for 2.0 miles to lease road; thence Northeast for 2.0 miles to lease road; thence North for 1.6 miles to proposed lease road.
 - C. Construct power lines and lay pipelines that will be necessary to produce this lease along road R-O-W.
- 2 PLANNED ACCESS ROADS: 1030.3' of proposed access road will be constructed on-lease.
 - A. The access road will be crowned and ditched to a 12' 00" wide travel surface with a 40' right-of-way.
 - B. Gradient on all roads will be less than 5.00%.
 - C. No turnouts will be necessary.
 - D. If needed road will be surfaced with a minimum of 4" of caliche. This material will be obtained from a
 - E. Ceterline for the new access road has been flagged. Earthwork will be required by field conditions.
 - F. Culverts in the access road will not be used. The road will be constructed to utilize low water crossings for drainage as required by the topography
- 3 LOCATION OF EXISTING WELLS IN A ONE-MILE RADIUS EXHIBIT "A"
 - A. Water wells - None known
 - B. Disposal wells - None known
 - C. Drilling wells - None known
 - D. Producing wells - As shown on Exhibit "A"
 - E. Abandoned wells - As shown on Exhibit "A"

Surface Use Plan

Cimarex Energy Co. of Colorado
Scout 18 Federal No. 12
Unit H Section 18
T19S R34E Lea County, NM

- 4 If, on completion, this well is a producer, Cimarex Energy Co. of Colorado will furnish maps and/or plats showing on-site facilities or off-site facilities if needed. This will be accompanied by a Sundry Notice.

5 LOCATION AND TYPE OF WATER SUPPLY:

Water will be purchased locally from a commercial source and trucked over the access roads or piped in flexible lines laid on top of the ground.

6 SOURCE OF CONSTRUCTION MATERIAL:

If possible construction will be obtained from the excavation of drill site, if additional material is needed it will be purchased from a local source and transported over the access route as shown on Exhibit "C".

7 METHODS OF HANDLING WASTE MATERIAL:

- A. Drill cuttings will be disposed of in the reserve pit.
- B. All trash, junk and other waste material will be contained in trash cages or bins to prevent scattering. When the job is completed all contents will be removed and disposed of in a approved sanitary land fill.
- C. Salts remaining after completion of well will be picked up by supplier including broken sacks.
- D. Sewage from living quarters will drain into holding tanks and be cleaned out periodically. A Porta-John will be provided for the rig crews. This equipment will be properly maintained during the drilling operations and removed upon completion of the well.
- E. Remaining drilling fluids will be allowed to evaporate in the reserve pit until the pit is dry enough for breaking out. In the event that drilling fluids do not evaporate in a reasonable time they will be hauled off by transports and be disposed of at a state approved disposal facility. Later pits will be broken out to speed drying. Water produced during testing will be put in reserve pits. Any oil or condensate produced will be stored in test tanks until sold and hauled from the site.

8 ANCILLARY FACILITIES:

- A. No camps or airstrips to be constructed.

Surface Use Plan

Cimarex Energy Co. of Colorado
Scout 18 Federal No. 12
Unit H Section 18
T19S R34E Lea County, NM

9 WELL SITE LAYOUT

- A. Exhibit "D" shows location and rig layout.
- B. This exhibit indicates proposed location of reserve and trash pits; and living facilities.
- C. Mud pits in the active circulating system will be steel pits and the reserve pit is proposed to be unlined, unless subsurface condition encountered during pit construction indicate that lining is needed for lateral containment of fluids.
- D. If needed, the reserve pit is to be lined with PVC or polyethylene line. The pit liner will be 12 mils thick. Pit liner will extend a minimum, 2'00" over the reserve pits dikes where the liner will be anchored down.
- E. The reserve pit will be fenced on three sides with four strands of barbed wire during drilling and completion phases. The fourth side will be fenced after all drilling operations have ceased. If the well is a producer, the reserve pit fence will be torn down. The reserve pit and those areas of the location not essential to production facilities will be reclaimed and seeded per BLM requirements.

10 PLANS FOR RESTORATION OF SURFACE

Rehabilitation of the location and reserve pit will start in a timely manner after all drilling operations cease. The type of reclamation will depend on whether the well is a producer or a dry hole.

However, in either event, the reserve pit will be allowed to dry properly, and fluid removed and disposed of in accordance with Article 7.B as previously noted. The pit area will then be leveled and contoured to conform to the original and surrounding area. Drainage systems, if any, will be reshaped to the original configuration with provisions made to alleviate erosion. These may need to be modified in certain circumstances to prevent inundation of the location's pad and surface facilities. After the area has been shaped and contoured, topsoil from the spoil pile will be placed over the disturbed area to the extent possible. Revegetation procedures will comply with BLM standards.

If the well is a dry hole, the pad and road area will be recontoured to match the existing terrain. Topsoil will be spread to the extent possible. Revegetation will comply with BLM standards.

Should the well be a producer, the previously noted procedures will apply to those areas which are not required for production facilities.

Surface Use Plan

Cimarex Energy Co. of Colorado
Scout 18 Federal No. 12
Unit H Section 18
T19S R34E Lea County, NM

11 OTHER INFORMATION:

- A. Topography consists of a sloping plane with loose tan sands. Vegetation is mainly yucca, mesquite and shin oak.
- B. The wellsite is on surface owned by The United States Department of the Interior, Bureau of Land Management. The land is used mainly for farming, cattle ranching, recreational use, and oil and gas production.
- C. An Archaeological survey will be conducted on the location and proposed roads, and this report will be filed with the Bureau of Land Management in the Carlsbad BLM office.
- D. There are no known dwellings within 1 1/2 mile of this location.

12 OPERATORS REPRESENTATIVE:

Cimarex Energy Co. of Colorado
P.O. Box 140907
Irving, TX 75014
Office Phone: (972) 443-6489
Zeno Farris

- 13 **CERTIFICATION:** I hereby certify that I, or persons under my direct supervision, have inspected the proposed drill site and access route; that I am familiar with the conditions which currently exist; that the statements made in this plan are to the best of my knowledge, true and correct; and that the work associated with the operations proposed herein will be performed by Cimarex Energy Co. of Colorado and/or its contractors/subcontractors and is in conformity with this plan and the terms and conditions under which it is approved. This statement is subject to the provision of U.S.C. 1001 for the filing of a false statement.

NAME: Zeno Farris

DATE: 11/17/2006

TITLE: Manager, Operations Administration

DISTRICT I
1625 N. French Dr., Hobbs, NM 88240

DISTRICT II
1301 W. Grand Avenue, Artesia, NM 88210

DISTRICT III
1000 Rio Brazos Rd., Artec, NM 87410

DISTRICT IV
1220 S. St. Francis Dr., Santa Fe, NM 87505

State of New Mexico
Energy, Minerals and Natural Resources Department

Form C-102
Revised October 12, 2005

Submit to Appropriate District Office
State Lease - 4 Copies
Fee Lease - 3 Copies

OIL CONSERVATION DIVISION
1220 South St. Francis Dr.
Santa Fe, New Mexico 87505

AMENDED REPORT

WELL LOCATION AND ACREAGE DEDICATION PLAT

API Number 30-025-38246	Pool Code 59470	Pool Name Tonto's 7 Rivers
Property Code 35708	Property Name SCOUT "18" FEDERAL	Well Number 12
OGRID No. 162683	Operator Name CIMAREX ENERGY CO. OF COLORADO	Elevation 3737'

Surface Location

UL or lot No.	Section	Township	Range	Lot Idn	Feet from the	North/South line	Feet from the	East/West line	County
H	18	19 S	34 E		2240	NORTH	750	EAST	LEA

Bottom Hole Location If Different From Surface

UL or lot No.	Section	Township	Range	Lot Idn	Feet from the	North/South line	Feet from the	East/West line	County

Dedicated Acres 40	Joint or Infill N	Consolidation Code	Order No.
------------------------------	-----------------------------	--------------------	-----------

NO ALLOWABLE WILL BE ASSIGNED TO THIS COMPLETION UNTIL ALL INTERESTS HAVE BEEN CONSOLIDATED OR A NON-STANDARD UNIT HAS BEEN APPROVED BY THE DIVISION

	<p>OPERATOR CERTIFICATION</p> <p><i>I hereby certify that the information contained herein is true and complete to the best of my knowledge and belief, and that this organization either owns a working interest or unleased mineral interest in the land including the proposed bottom hole location pursuant to a contract with an owner of such a mineral or working interest, or to a voluntary pooling agreement or a compulsory pooling order heretofore entered by the division.</i></p> <p>Zeno Farris 11-17-06 Signature Date</p> <p>Zeno Farris Printed Name</p>	
	<p>SURVEYOR CERTIFICATION</p> <p><i>I hereby certify that the well location shown on this plat was plotted from field notes of actual surveys made by me or under my supervision, and that the same is true and correct to the best of my belief.</i></p> <p>NOVEMBER 09, 2006 Date Signed</p> <p>Gary L. Jones Signature Professional Surveyor</p> <p>7977 Professional Surveyor No.</p>	
	<p>Lat - N32°39'40.7" Long - W103°35'36.4" NMSPC - N 605110.6 E 769036.8 (NAD-83)</p>	<p>374</p>
	<p>Certificate No. Gary L. Jones 7977</p> <p>BASIN SURVEYS</p>	

SECTION 18, TOWNSHIP 19 SOUTH, RANGE 34 EAST, N.M.P.M.,
LEA COUNTY, NEW MEXICO.

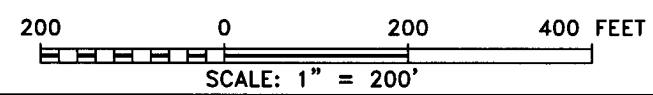
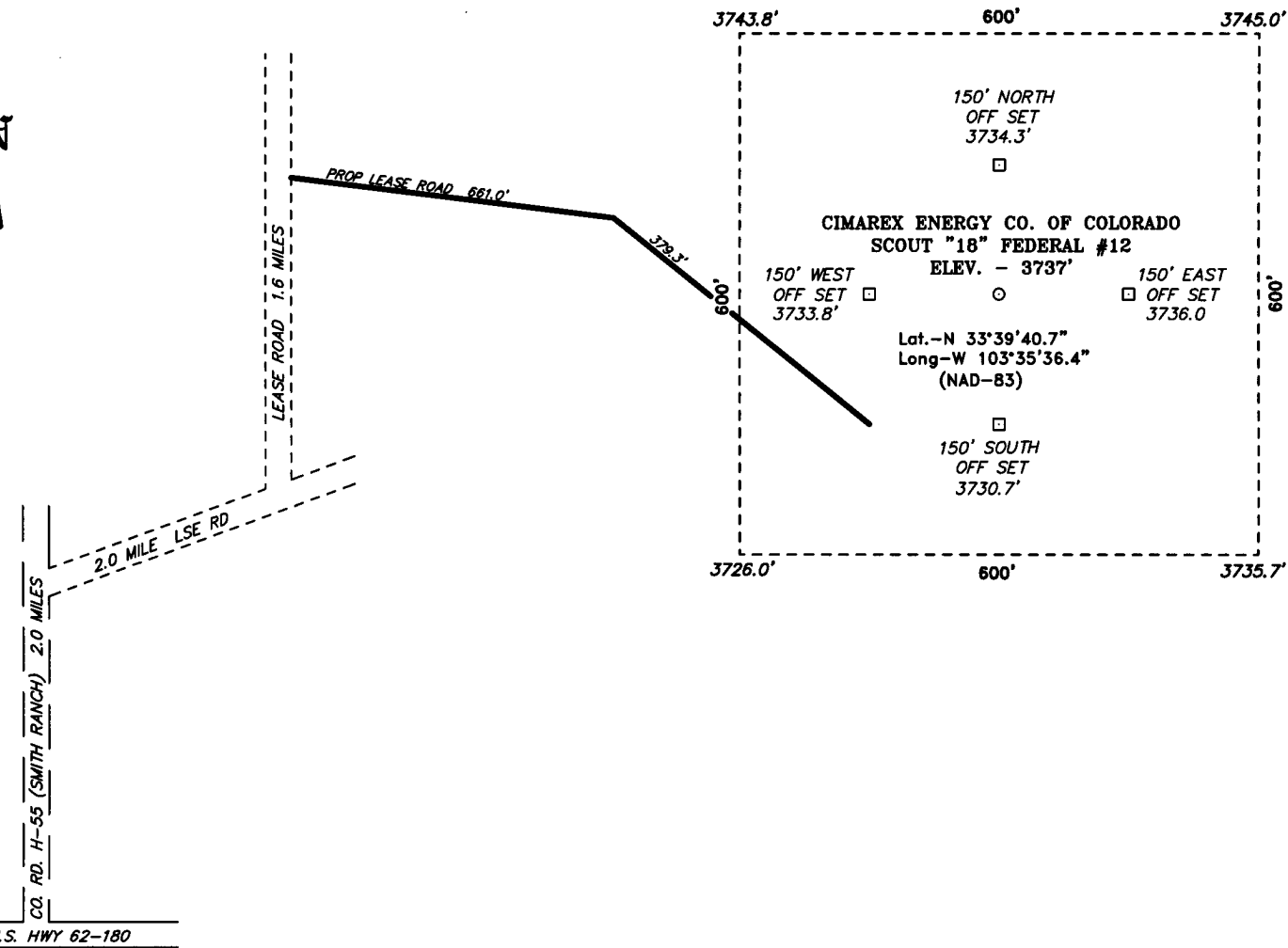

Directions to Location:

FROM THE JUNCTION OF US HWY 62-180 AND CO. RD. H-55 (SMITH RANCH), PROCEED NORTH 2.0 MILE TO LEASE ROAD, ON LEASE ROAD PROCEED 2.0 MILES NORTHEAST TO LEASE ROAD, ON LEASE ROAD PROCEED NORTH 1.6 MILES TO PROPOSED LEASE ROAD.

CIMAREX ENERGY CO. OF COLORADO	
REF: SCOUT "18" FEDERAL #12 / WELL PAD TOPO	
THE SCOUT "18" FEDERAL #12 LOCATED 2240' FROM THE NORTH LINE AND 750' FROM THE EAST LINE OF SECTION 18, TOWNSHIP 19 SOUTH, RANGE 34 EAST, N.M.P.M., LEA COUNTY, NEW MEXICO.	

BASIN SURVEYS P.O. BOX 1786-HOBBS, NEW MEXICO

W.O. Number: 17374	Drawn By: J. M. SMALL
Date: 11-10-2006	Disk: JMS 17374W

Survey Date: 11-09-2006 Sheet 1 of 1 Sheets

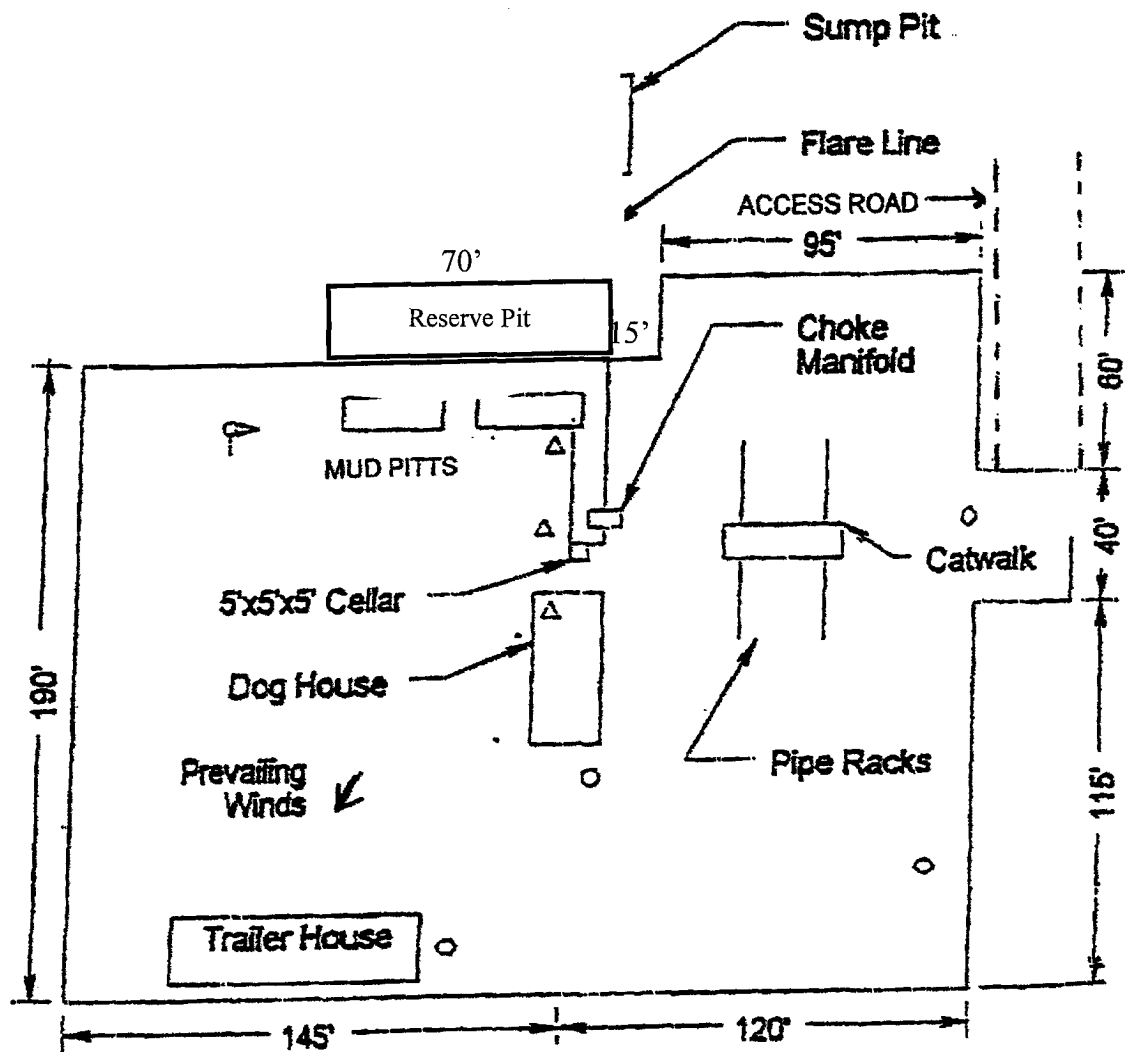

- ☛ Wind Direction indicators (wind sock or streamers)
- △ H2S Monitors (alarms at bell nipple and shale shaker)
- Briefing Areas
- Remote BOP Closing Unit
- Sign and Condition Flags

Exhibit D – Rig Layout Plan
 Scout 18 Federal No. 12
 Cimarex Energy Co. of Colorado
 Section 18-T19S-R34E
 2240' FNL & 750' FEL
 Lea County, NM

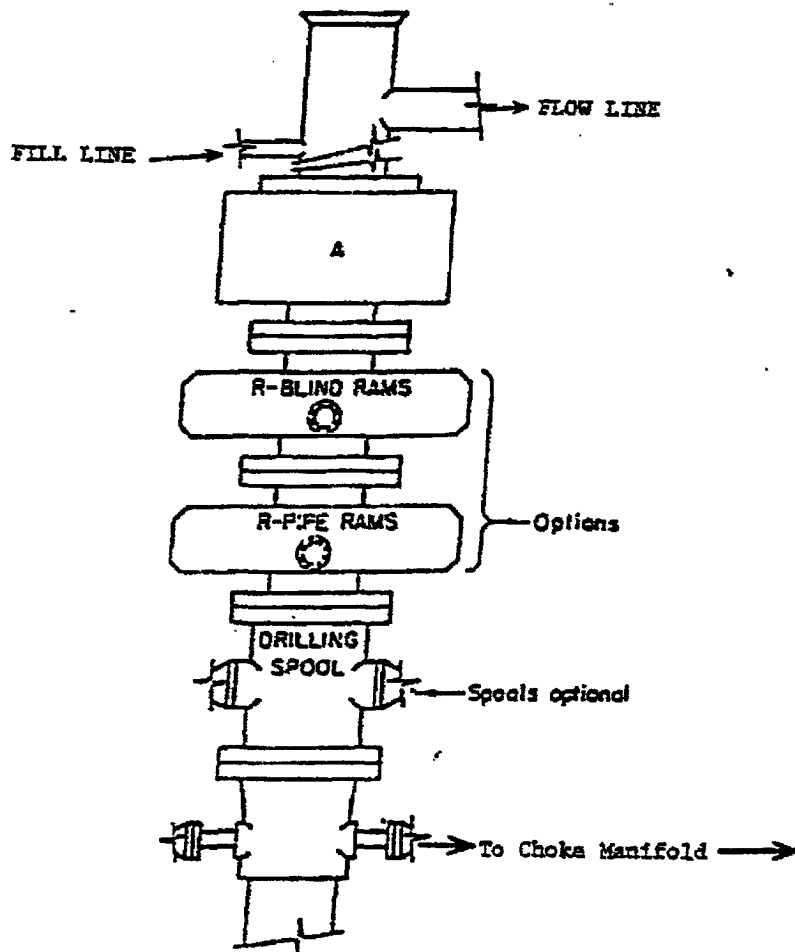

ARRANGEMENT SBRA

900 Series
3000 PSI WP

Exhibit E – Blowout Preventor
Scout 18 Federal No. 12
 Cimarex Energy Co. of Colorado
 Section 18-T19S-R34E
 2240' FNL & 750' FEL
 Lea County, NM

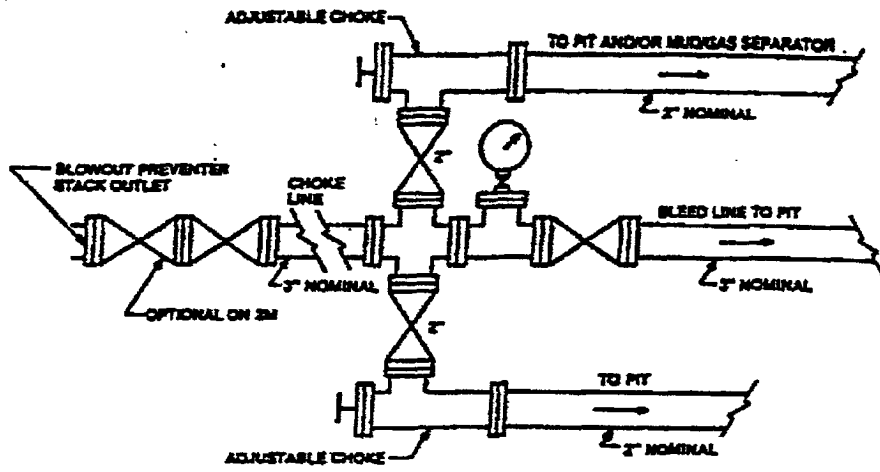

Typical choke manifold assembly for 3M WP system

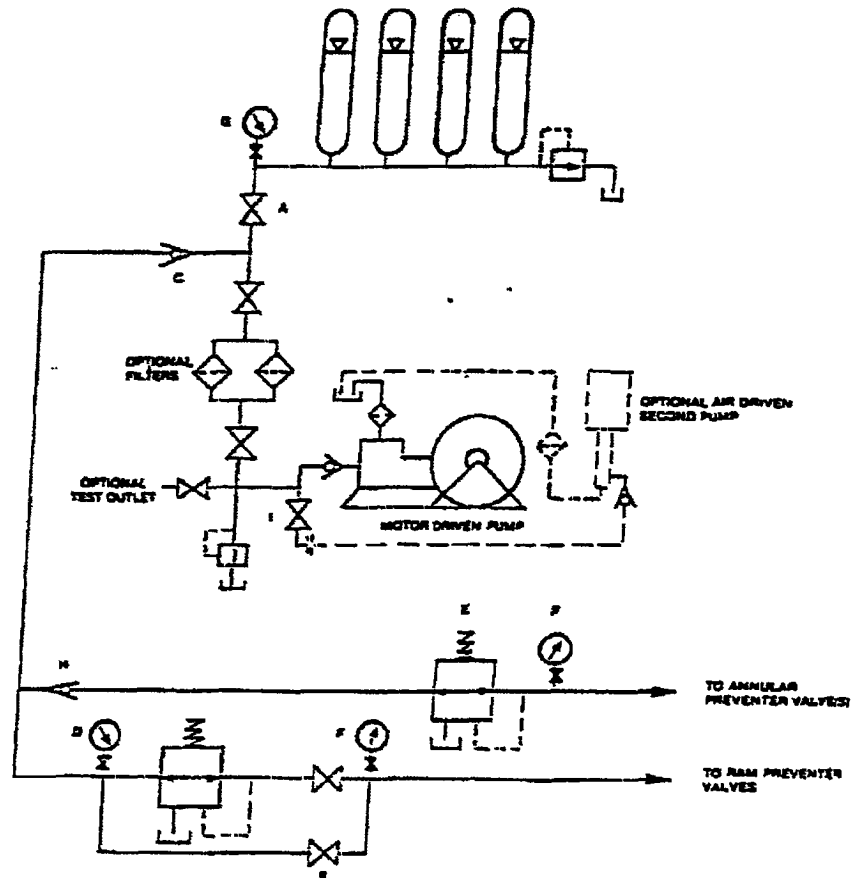

Exhibit E1 - Choke Manifold
 Scout 18 Federal No. 12
 Cimarex Energy Co. of Colorado
 Section 18-T19S-R34E
 2240' FNL & 750' FEL
 Lea County, NM

CONDITIONS OF APPROVAL - DRILLING

Well Name & No. **12-Scout 18 Federal**
Operator's Name: **Cimarex Energy Co. of Colorado**
Location: **2240FNL, 0750FEL, Section 18, T-19-S, R-34-E**
Lease: **NM-3622**

I. DRILLING OPERATIONS REQUIREMENTS:

1. The Bureau of Land Management (BLM) is to be notified at the Carlsbad Field Office, 620 East Greene St., Carlsbad, NM 88220, (505) 234-5972 or (505) 361-2822 - for wells in Eddy County; and the Hobbs Field Station, 414 West Taylor, Hobbs NM 88240, (505) 393-3612 for wells in Lea County, in sufficient time for a representative to witness:

A. Spudding

B. Cementing casing: 8-5/8 inch 5-1/2 inch

C. BOP tests

2. **H₂S has been reported in Sections 4, 6, and 7 ranging from 200-600 ppm in the gas streams of the La Rica and Quail Ridge fields.** A Hydrogen Sulfide (H₂S) Drilling Plan is attached to the APD.

3 Unless the production casing has been run and cemented or the well has been properly plugged, the drilling rig shall not be removed from over the hole without prior approval.

4. Submit a Sundry Notice (Form 3160-5, one original and five copies) for each casing string, describing the casing and cementing operations. Include pertinent information such as; spud date, hole size, casing (size, weight, grade and thread type), cement (type, quantity and top), water zones and problems or hazards encountered. The Sundry shall be submitted within 15 days of completion of each casing string. The reports may be combined into the same Sundry if they fall within the same 15 day time frame.

5. The API No. assigned to the well by NMOCD shall be included on the subsequent report of setting the first casing string.

6. Gamma-Ray/Neutron logs shall be run from the base of the Salado Formation to the surface; cable speed not to exceed 30 feet per minute.

II. CASING:

1. The 8-5/8 inch surface casing shall be set approximately 900 feet, below usable water and cement circulated to the surface. If cement does not circulate to the surface the appropriate BLM office shall be notified and a temperature survey or cement bond log shall be run to verify the top of the cement. Remedial cementing shall be completed prior to drilling out that string.

Fresh water mud to be used to the top of the Rustler Anhydrite approximately 1620 feet.

Possible lost circulation in the Redbeds, Grayburg and Bone Spring formations.

2. The minimum required fill of cement behind the 5-1/2 inch production casing is cement shall circulate to surface.

III. PRESSURE CONTROL:

1. All BOP systems and related equipment shall comply with well control requirements as described in Onshore Oil and Gas Order No. 2. The BOP and related equipment shall be installed and operational before drilling below the 8-5/8 inch casing shoe and shall be tested as described in Onshore Order No. 2. Any equipment failing to test satisfactorily shall be repaired or replaced.
2. Minimum working pressure of the blowout preventer and related equipment (BOPE) required for drilling below the 8-5/8 inch casing shall be 3M psi.
3. The appropriate BLM office shall be notified in sufficient time for a representative to witness the tests.
 - The tests shall be done by an independent service company.
 - The results of the test shall be reported to the appropriate BLM office.
 - Testing fluid must be water or an appropriate clear liquid suitable for sub-freezing temperatures. Use of drilling mud for testing is not permitted since it can mask small leaks.
 - Testing must be done in a safe workman-like manner. Hard line connections shall be required.

Engineer on call phone: 505-706-2779

WWI 121206

District I
1625 N. French Dr., Hobbs, NM 88240
District II
1301 W. Grand Avenue, Artesia, NM 88210
District III
1000 Rio Brazos Road, Aztec, NM 87410
District IV
1220 S. St. Francis Dr., Santa Fe, NM 87505

State of New Mexico
Energy Minerals and Natural Resources
Oil Conservation Division
1220 South St. Francis Dr.
Santa Fe, NM 87505

Form C-144
March 12, 2004

For drilling and production facilities, submit to appropriate NMOCD District Office.
For downstream facilities, submit to Santa Fe office

Pit or Below-Grade Tank Registration or Closure

Is pit or below-grade tank covered by a "general plan"? Yes No
Type of action: Registration of a pit or below-grade tank Closure of a pit or below-grade tank

Operator: Cimarex Energy Co. of Colorado Telephone: 972-443-6489 e-mail address: zfarris@cimarex.com
Address: P.O. Box 140907, Irving, Tx 75014-0907
Facility or well name: Scout 18 Federal No. 12 API #: 30-025-38246 U/L or Qtr/Qtr^H Sec 18 T 19S R 34E
County: Lea Latitude 323940.7 N Longitude 1033536.4 W NAD: 1927 1983 Surface Owner Federal State Private Indian

Pit Type: Drilling <input checked="" type="checkbox"/> Production <input type="checkbox"/> Disposal <input type="checkbox"/> Workover <input type="checkbox"/> Emergency <input type="checkbox"/> Lined <input checked="" type="checkbox"/> Unlined <input type="checkbox"/> Liner type: Synthetic <input checked="" type="checkbox"/> Thickness <u>12</u> mil Clay <input type="checkbox"/> Volume <u>12000</u> bbl	Below-grade tank Volume: _____ bbl Type of fluid: _____ Construction material: _____ Double-walled, with leak detection? Yes <input type="checkbox"/> If not, explain why not. _____	
Depth to ground water (vertical distance from bottom of pit to seasonal high water elevation of ground water.)	Less than 50 feet 50 feet or more, but less than 100 feet <u>100 feet or more</u>	(20 points) (10 points) <u>(0 points)</u>
Wellhead protection area: (Less than 200 feet from a private domestic water source, or less than 1000 feet from all other water sources.)	Yes <u>No</u>	(20 points) <u>(0 points)</u>
Distance to surface water: (horizontal distance to all wetlands, playas, irrigation canals, ditches, and perennial and ephemeral watercourses.)	Less than 200 feet 200 feet or more, but less than 1000 feet <u>1000 feet or more</u>	(20 points) (10 points) <u>(0 points)</u>
Ranking Score (Total Points)		0

If this is a pit closure: (1) attach a diagram of the facility showing the pit's relationship to other equipment and tanks. (2) Indicate disposal location: onsite offsite If offsite, name of facility: _____ (3) Attach a general description of remedial action taken including remediation start date and end date. (4) Groundwater encountered: No Yes If yes, show depth below ground surface _____ ft. and attach sample results. (5) Attach soil sample results and a diagram of sample locations and excavations.

I hereby certify that the information above is true and complete to the best of my knowledge and belief. I further certify that the above-described pit or below-grade tank has been/will be constructed or closed according to NMOCD guidelines , a general permit , or an (attached) alternative OCD-approved plan .

Date: 11-17-06

Printed Name/Title Zeno Farris Manager Operations Administration

Signature Zeno Farris

Your certification and NMOCD approval of this application/closure does not relieve the operator of liability should the contents of the pit or tank contaminate ground water or otherwise endanger public health or the environment. Nor does it relieve the operator of its responsibility for compliance with any other federal, state, or local laws and/or regulations.

Approval:

Date: 1/5/07

Printed Name/Title CHRIS WILLIAMS / DIST. SUP

Signature Chris Williams