

Submit 3 Copies To Appropriate District Office  
 District I  
 1625 N French Dr, Hobbs, NM 88240  
 District II  
 1301 W Grand Ave, Artesia, NM 88210  
 District III  
 1000 Rio Brazos Rd., Aztec, NM 87410  
 District IV  
 1220 S St Francis Dr, Santa Fe, NM 87505

State of New Mexico  
 Energy, Minerals and Natural Resources

Form C-103  
 May 27, 2004

OIL CONSERVATION DIVISION  
 1220 South St. Francis Dr.  
 Santa Fe, NM 87505

WELL API NO. 30-025-38522	<input checked="" type="checkbox"/>
5. Indicate Type of Lease STATE <input checked="" type="checkbox"/> FEE <input type="checkbox"/>	
6. State Oil & Gas Lease No. V-7720	
7. Lease Name or Unit Agreement Name White Fang State	<input checked="" type="checkbox"/>
8. Well Number 1	<input checked="" type="checkbox"/>
9. OGRID Number 013837	<input checked="" type="checkbox"/>
10. Pool name or Wildcat Baum;Wolfcamp, North	

SUNDRY NOTICES AND REPORTS ON WELLS  
 (DO NOT USE THIS FORM FOR PROPOSALS TO DRILL OR TO DEEPEN OR PLUG BACK TO A DIFFERENT RESERVOIR USE "APPLICATION FOR PERMIT" (FORM C-101) FOR SUCH PROPOSALS )

1. Type of Well: Oil Well  Gas Well  Other

2. Name of Operator  
Mack Energy Corporation

3. Address of Operator  
P. O. Box 960 Artesia, NM 88211-0960

4. Well Location  
 Unit Letter P 990 feet from the South line and 990 feet from the East line  
 Section 10 Township 13S Range 32E NMPM County Lea

11. Elevation (Show whether DR, RKB, RT, GR, etc.)  
4318' GR

Pit or Below-grade Tank Application  or Closure

Pit type \_\_\_\_\_ Depth Groundwater \_\_\_\_\_ Distance from nearest fresh water well \_\_\_\_\_ Distance from nearest surface water \_\_\_\_\_

Pit Liner Thickness: \_\_\_\_\_ mil Below-Grade Tank: Volume \_\_\_\_\_ bb1s; Construction Material \_\_\_\_\_

12. Check Appropriate Box to Indicate Nature of Notice, Report or Other Data

NOTICE OF INTENTION TO:

- PERFORM REMEDIAL WORK  PLUG AND ABANDON
- TEMPORARILY ABANDON  CHANGE PLANS
- PULL OR ALTER CASING  MULTIPLE COMPL

OTHER: \_\_\_\_\_

SUBSEQUENT REPORT OF:

- REMEDIAL WORK  ALTERING CASING
- COMMENCE DRILLING OPNS.  P AND A
- CASING/CEMENT JOB

OTHER: \_\_\_\_\_

13. Describe proposed or completed operations. (Clearly state all pertinent details, and give pertinent dates, including estimated date of starting any proposed work). SEE RULE 1103. For Multiple Completions: Attach wellbore diagram of proposed completion or recompletion.

Notify OCD 24 hours prior to starting plugging operations.

- 1) Set CIBP @ 9315' w/ 25sx cmt plug.
- 2) Set 25sx cmt plug at 6500'.
- 3) Set 25sx cmt plug at 4100', WOC tag.
- 4) Set 25sx cmt plug at 1560'.
- 5) Set 50sx cmt plug from 500' to surface.
- 6) Install dry hole marker.

Note: Circ. well with salt gel mud consisting of at least 9.5# Brine with 25 pounds of gel per barrel after the bottom plug is set. No pit needed.

**THE OIL CONSERVATION DIVISION MUST BE NOTIFIED 24 HOURS PRIOR TO THE BEGINNING OF PLUGGING OPERATIONS.**

I hereby certify that the information above is true and complete to the best of my knowledge and belief. I further certify that any pit or below-grade tank has been/will be constructed or closed according to NMOCD guidelines  a general permit  or an (attached) alternative OCD-approved plan

SIGNATURE Jerry W. Sherrell TITLE Production Clerk DATE 1/23/08

Type or print name Jerry W. Sherrell E-mail address: jerrys@mackenergycorp.com Telephone No. (575)748-1288

For State Use Only  
 APPROVED BY: Chris Williams TITLE OC DISTRICT SUPERVISOR/GENERAL MANAGER DATE FEB 06 2008  
 Conditions of Approval (if any):

**Mack Energy Corporation**  
**White Fang State #1**

**Before**

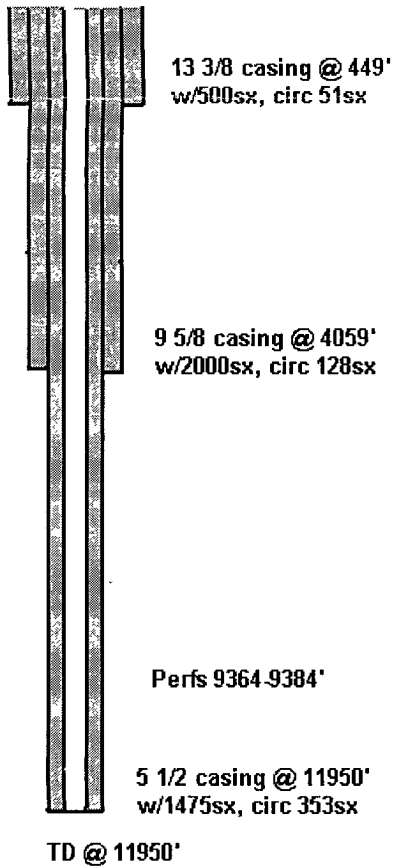

**After**

