

CHEVRON DRILLING SERVICES REFERENCE SERIES  
 VOLUME ELEVEN  
 WELL CONTROL AND BLOWOUT PREVENTION

**D. CLASS III CHOKE MANIFOLD**

The Class III choke manifold is suitable for Class III workovers and drilling operations. The Standard Class III choke manifold is shown in Figure 11J.8 below. Specific design features of the Class III manifold include:

1. The manifold is attached to a drilling spool or the top ram preventer side outlet.
2. The minimum internal diameter is 2" (nominal) for outlets, flanges, valves and lines.
3. Includes two steel gate valves in the choke line at the drilling spool outlet. The inside choke line valve may be remotely controlled (HCR).
4. Includes two manually adjustable chokes which are installed on both side of the manifold cross. Steel isolation gate valves are installed between both chokes and the cross, and also downstream of both chokes.
5. Includes a bleed line which runs straight through the cross and is isolated by a steel gate valve.
6. Includes a valve isolated pressure gauge suitable for drilling service which can display the casing pressure within view of the choke operator.
7. Returns through the choke manifold must be divertible through a mud-gas separator and then be routed to either the shale shaker or the reserve pit through a buffer tank or manifold arrangement.
8. If the choke manifold is remote from the wellhead, a third master valve should be installed immediately upstream of the manifold cross.

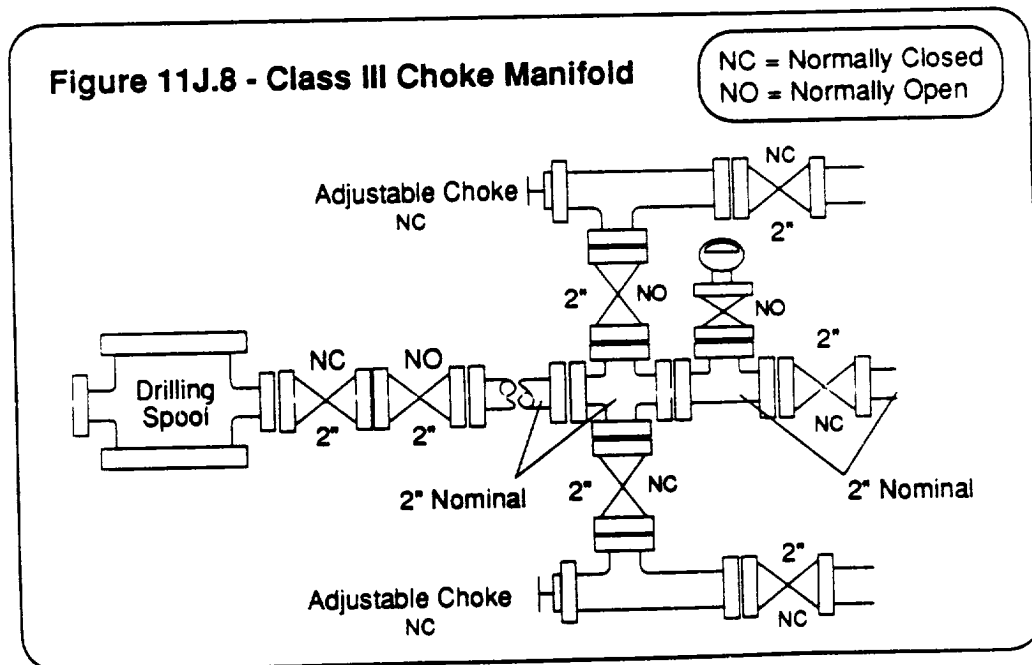

E. CLASS III BLOWOUT PREVENTER STACK:

The Class III preventer stack is designed for drilling or workover operations. It is composed of a single hydraulically operated annular preventer on top, then a blind ram preventer, a drilling spool, and a single pipe ram preventer on bottom. The choke and kill lines are installed onto the drilling spool and must have a minimum internal diameter of 2". All side outlets on the preventers or drilling spool must be flanged, studded, or clamped. An emergency kill line may be installed on the wellhead. A double ram preventer should only be used when space limitations make it necessary to remove the drilling spool. In these instances, the choke manifold should be connected to a flanged outlet between the preventer rams only. In this hookup, the pipe rams are considered master rams only, and cannot be used to routinely circulate out a kick. The Class III blowout preventer stack is shown to the right in Figure 11J.4.

