

District I
 PO Box 1980, Hobbs, NM 88241-1980
 District II
 PO Drawer DD, Artesia, NM 88211-0719
 District III
 1000 Rio Brazos Rd., Aztec, NM 87410
 District IV
 PO Box 2088, Santa Fe, NM 87504-2088

State of New Mexico
 Energy, Minerals & Natural Resources Department

OIL CONSERVATION DIVISION
 PO Box 2088
 Santa Fe, NM 87504-2088

Form C-101
 Revised February 10, 1994
 Instructions on back
 Submit to Appropriate District Office
 State Lease - 6 Copies
 Fee Lease - 5 Copies

AMENDED REPORT

APPLICATION FOR PERMIT TO DRILL, RE-ENTER, DEEPEN, PLUGBACK, OR ADD A ZONE

¹ Operator Name and Address. GECKO 310 W. Wall, Suite 702 - LB106 Midland, Texas 79701		¹ OGRID Number 025739
⁴ Property Code 17247		³ API Number 30 - 025 - 33022
² Property Name GECKO "22" State GECKO STATE -- 22 --		⁶ Well No. 1

⁷ Surface Location

UL or lot no.	Section	Township	Range	Lot Idn	Feet from the	North/South line	Feet from the	East/West line	County
E	22	21S	35E		1980	N	660	W	Lea

⁸ Proposed Bottom Hole Location If Different From Surface

UL or lot no.	Section	Township	Range	Lot Idn	Feet from the	North/South line	Feet from the	East/West line	County

⁹ Proposed Pool 1 Wildcat	¹⁰ Proposed Pool 2 Wildcat
---	--

¹¹ Work Type Code N	¹² Well Type Code O	¹³ Cable/Rotary R	¹⁴ Lease Type Code S	¹⁵ Ground Level Elevation 3594
¹⁶ Multiple No	¹⁷ Proposed Depth 11,500	¹⁸ Formation Strawn	¹⁹ Contractor McVay	²⁰ Spud Date 9/1/95

²¹ Proposed Casing and Cement Program

Hole Size	Casing Size	Casing weight/foot	Setting Depth	Sacks of Cement	Estimated TOC
17-1/2	13-3/8	54	1,700		Circulated
11	8-5/8	32	5,600		1500'
7-7/8	5-1/2	17	11,500	500	9000'

²² Describe the proposed program. If this application is to DEEPEN or PLUG BACK give the data on the present productive zone and proposed new productive zone. Describe the blowout prevention program, if any. Use additional sheets if necessary.

See Attached

Permit Expires 6 Months From Approval
 Date Unless Drilling Underway.

²³ I hereby certify that the information given above is true and complete to the best of my knowledge and belief. Signature: <i>Steve L. Thomson</i>		OIL CONSERVATION DIVISION	
Printed name: Steve L. Thomson		Approved by: ORIGINAL SIGNED BY JERRY SEXTON	
Title: President		Title: DISTRICT I SUPERVISOR	
Date: 7/5/95	Phone: (915) 686-0121	Approval Date: JUL 11 1995	Expiration Date:
		Conditions of Approval: Attached <input type="checkbox"/>	

GECKO

310 W. WALL

SUITE 702 - LB 106

MIDLAND, TEXAS 79701

(915) 686-0121

FAX: (915) 686-0134

GECKO State -22- No. 1
Section 22, T-21-S, R-35-E
Lea County, New Mexico

23. Proposed drilling program

Operator will drill a 17-1/2" hole to 1700' with Fresh Water. At 1700', operator will set 13-3/8" casing and cement same to surface. An 11" hole will be drilled from 1700' to 5600' with a cut brine mud system. At 5600', and intermediate string of 8-5/8" casing will be set and cemented to surface. A 3000 psig annular preventer will be used on the intermediate hole (diagram attached). A 7-7/8" hole will be drilled from 5600' to 11,500' or a depth sufficient to test the Strawn. A fresh water mud will be utilized. A 3000 psig annular and a 5000 psig dual pipe ram BOP stack will be utilized for well control (diagram attached). Mudup will occur at +/- 10,000' or as hole conditions dictate. Drill stem testing will occur as zones of interest warrant.

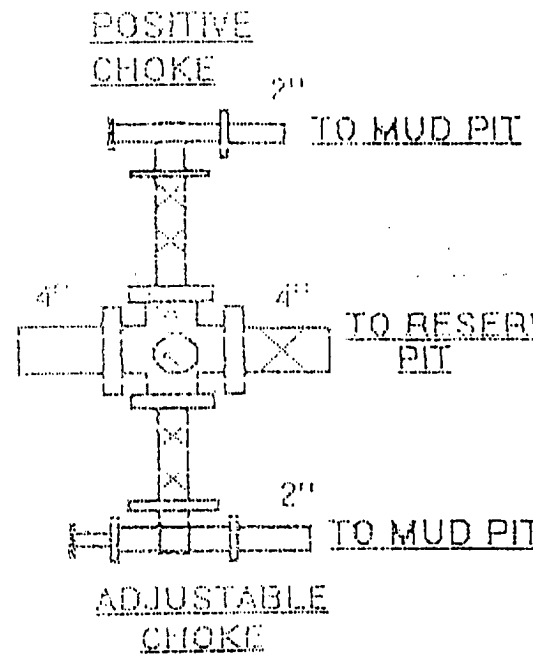
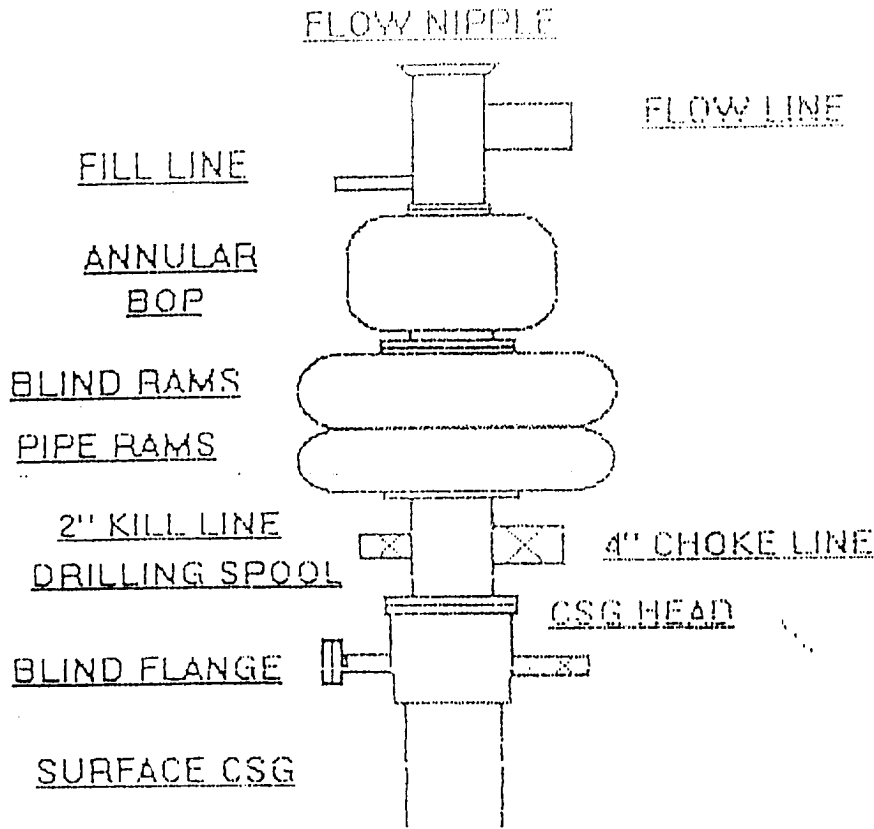

BOP AND CHOKE DIAGRAM
 GECKO, INC.

RECEIVED
JUL 10 1985
USD HODES
OFFICE

District I
PO Box 1980, Hobbs, NM 88241-1980

District II
PO Drawer DD, Artesia, NM 88211-0719

District III
1000 Rio Brasos Rd., Aztec, NM 87410

District IV
PO Box 2088, Santa Fe, NM 87504-2088

State of New Mexico
Energy, Minerals & Natural Resources Department

Form C-102
Revised February 10, 1994
Submit to Appropriate District Office
State Lease - 4 Copies
Fee Lease - 3 Copies

OIL CONSERVATION DIVISION

PO Box 2088
Santa Fe, NM 87504-2088

AMENDED REPORT

WELL LOCATION AND ACREAGE DEDICATION PLAT

1 API Number 30-025-33022		2 Pool Code 96039		3 Pool Name Wildcat Strawn	
4 Property Code 17247		5 Property Name GECKO State "22"			6 Well Number 1
7 OGRID No. 025739		8 Operator Name GECKO		9 Elevation 3594	

10 Surface Location

UL or lot no.	Section	Township	Range	Lot Idn	Feet from the	North/South line	Feet from the	East/West line	County
E	22	21 S	35 E	E	1980	North	660	West	Lea

11 Bottom Hole Location If Different From Surface

UL or lot no.	Section	Township	Range	Lot Idn	Feet from the	North/South line	Feet from the	East/West line	County

12 Dedicated Acres 40	13 Joint or Infill	14 Consolidation Code	15 Order No.
---------------------------------	--------------------	-----------------------	--------------

NO ALLOWABLE WILL BE ASSIGNED TO THIS COMPLETION UNITL ALL INTERESTS HAVE BEEN CONSOLIDATED OR A NON-STANDARD UNIT HAS BEEN APPROVED BY THE DIVISION

<p>16</p>	<p>17 OPERATOR CERTIFICATION</p> <p><i>I hereby certify that the information contained herein is true and complete to the best of my knowledge and belief.</i></p> <p><i>Steve L. Thomson</i> Signature</p> <p>Steve L. Thomson Printed Name</p> <p>President Title</p> <p>7/5/95 Date</p>		
	<p>18 SURVEYOR CERTIFICATION</p> <p><i>I hereby certify that the well location shown on this plat was plotted from field notes of actual surveys made by me or under my supervision, and that the same is true and correct to the best of my belief.</i></p> <p>June 23, 1995 Date of Survey</p> <p>Signature and Seal of Professional Surveyor.</p> <p><i>Michael L. Stanford</i> Certificate Number 10324</p>		

RECEIVED

JUL 16 1995

**UCC HOBBS
OFFICE**