



February 16, 2026

New Mexico Oil Conservation Division
1220 S. St. Francis Drive
Sante Fe, NM 87505

Via Electronic Submittal

RE: C-144 Temporary Pit Application
ZN 34 3 FED COM (Pad 13) (419H, 420H, 421H, 619H, 620H, 621H)
Section 34 of T23S, R34E, Lea County

Dear NMOCD Representative,

Enclosed is a complete C-144 permit application for a Temporary Pit with non-low chloride drilling fluid located at existing Chevron U.S.A. Inc. BLM leases NMNM02377 and NMNM0327106 located in Section 34, T23S R34E. This package includes the following documentation:

- C-144 for Non-Low Chloride Temporary Pit
- Siting Criteria Demonstration
- Siting Criteria Figures 1-11
- Variance Requests
- Appendix A – USGS Groundwater Data
- Appendix B – NMOSE Water Data
- Appendix C – Hydrogeologic Data
- Appendix D – Design Plan
- Appendix E – Operating and Maintenance Plan
- Appendix F – Closure Plan
- Appendix G – Evaluation of Unstable Conditions
- Attachments

Please do not hesitate to contact us if you require any additional information or clarification supporting the approval of this application.

Respectfully,

Adriane Kenney
Sr. Environmental Specialist
AKenney@chevron.com

Austin White
Drilling Engineer
Austin.White@chevron.com

Charles Holder
Arcadis U.S. Inc. Project Manager
Charles.Holder@arcadis.com

Chevron U.S.A. Inc.
1500 Louisiana Street
Houston, TX 77002
Tel 832 854 5620

C-144 Permit Package

ZN 34 3 FED COM (Pad 13) Temporary Pit Section 34 of T23S, R34E, Lea County

ZN 34 3 FED COM #419H
ZN 34 3 FED COM #420H
ZN 34 3 FED COM #421H
ZN 34 3 FED COM #619H
ZN 34 3 FED COM #620H
ZN 34 3 FED COM #621H

Chevron U.S.A. Inc.

District I
1625 N. French Dr., Hobbs, NM 88240
District II
811 S. First St., Artesia, NM 88210
District III
1000 Rio Brazos Road, Aztec, NM 87410
District IV
1220 S. St. Francis Dr., Santa Fe, NM 87505

State of New Mexico
Energy Minerals and Natural Resources
Department
Oil Conservation Division
1220 South St. Francis Dr.
Santa Fe, NM 87505

Form C-144
Revised April 3, 2017

For temporary pits, below-grade tanks, and multi-well fluid management pits, submit to the appropriate NMOCD District Office.
For permanent pits submit to the Santa Fe Environmental Bureau office and provide a copy to the appropriate NMOCD District Office.

Pit, Below-Grade Tank, or
Proposed Alternative Method Permit or Closure Plan Application

- Type of action: Below grade tank registration
 Permit of a pit or proposed alternative method
 Closure of a pit, below-grade tank, or proposed alternative method
 Modification to an existing permit/or registration
 Closure plan only submitted for an existing permitted or non-permitted pit, below-grade tank, or proposed alternative method

Instructions: Please submit one application (Form C-144) per individual pit, below-grade tank or alternative request

Please be advised that approval of this request does not relieve the operator of liability should operations result in pollution of surface water, ground water or the environment. Nor does approval relieve the operator of its responsibility to comply with any other applicable governmental authority's rules, regulations or ordinances.

1.
Operator: Chevron U.S.A. Inc. OGRID #: 4323
Address: 6301 Deauville Blvd., Midland, TX 79706
Facility or well name: ZN 34 3 FEED COM (Pad 13) (419H,420H,421H,619H,620H,621H)
API Number: pending, pending, pending, 30-025-55733, -30-025-55777, 30-025-55778 OCD Permit Number: _____
U/L or Qtr/Qtr A Section 34 Township 23S Range 34E County: Lea
Center of Proposed Design: Latitude 32.267038° Longitude -103.450737° NAD83
Surface Owner: Federal State Private Tribal Trust or Indian Allotment

2.
 Pit: Subsection F, G or J of 19.15.17.11 NMAC
Temporary: Drilling Workover
 Permanent Emergency Cavitation P&A Multi-Well Fluid Management Low Chloride Drilling Fluid yes no
 Lined Unlined Liner type: Thickness 40 mil LLDPE HDPE PVC Other _____
 String-Reinforced
Liner Seams: Welded Factory Other _____ Volume: 1 x 18,095 bbl, 1 x 10,909 bbl Dimensions: L 327 ft x W 216 ft x D 8 ft

3.
 Below-grade tank: Subsection I of 19.15.17.11 NMAC
Volume: _____ bbl Type of fluid: _____
Tank Construction material: _____
 Secondary containment with leak detection Visible sidewalls, liner, 6-inch lift and automatic overflow shut-off
 Visible sidewalls and liner Visible sidewalls only Other _____
Liner type: Thickness _____ mil HDPE PVC Other _____

4.
 Alternative Method:
Submittal of an exception request is required. Exceptions must be submitted to the Santa Fe Environmental Bureau office for consideration of approval.

5.
Fencing: Subsection D of 19.15.17.11 NMAC (Applies to permanent pits, temporary pits, and below-grade tanks)
 Chain link, six feet in height, two strands of barbed wire at top (Required if located within 1000 feet of a permanent residence, school, hospital, institution or church)
 Four foot height, four strands of barbed wire evenly spaced between one and four feet
 Alternate. Please specify _____

6.
Netting: Subsection E of 19.15.17.11 NMAC (*Applies to permanent pits and permanent open top tanks*)
 Screen Netting Other _____
 Monthly inspections (If netting or screening is not physically feasible)

7.
Signs: Subsection C of 19.15.17.11 NMAC
 12"x 24", 2" lettering, providing Operator's name, site location, and emergency telephone numbers
 Signed in compliance with 19.15.16.8 NMAC

8.
Variations and Exceptions:
 Justifications and/or demonstrations of equivalency are required. Please refer to 19.15.17 NMAC for guidance.
Please check a box if one or more of the following is requested, if not leave blank:
 Variance(s): Requests must be submitted to the appropriate division district for consideration of approval. **See Variance Requests**
 Exception(s): Requests must be submitted to the Santa Fe Environmental Bureau office for consideration of approval.

9.
Siting Criteria (regarding permitting): 19.15.17.10 NMAC
Instructions: The applicant must demonstrate compliance for each siting criteria below in the application. Recommendations of acceptable source material are provided below. Siting criteria does not apply to drying pads or above-grade tanks.

General siting	
Ground water is less than 25 feet below the bottom of a low chloride temporary pit or below-grade tank. - <input type="checkbox"/> NM Office of the State Engineer - iWATERS database search; <input type="checkbox"/> USGS; <input type="checkbox"/> Data obtained from nearby wells	<input type="checkbox"/> Yes <input type="checkbox"/> No <input checked="" type="checkbox"/> NA
Ground water is less than 50 feet below the bottom of a Temporary pit, permanent pit, or Multi-Well Fluid Management pit. - <input checked="" type="checkbox"/> NM Office of the State Engineer - iWATERS database search; <input checked="" type="checkbox"/> USGS; <input type="checkbox"/> Data obtained from nearby wells See Appendices A, B, Figure 7	<input type="checkbox"/> Yes <input checked="" type="checkbox"/> No <input type="checkbox"/> NA
Within incorporated municipal boundaries or within a defined municipal fresh water well field covered under a municipal ordinance adopted pursuant to NMSA 1978, Section 3-27-3, as amended. (Does not apply to below grade tanks) - Written confirmation or verification from the municipality; Written approval obtained from the municipality See Figures 2 & 7	<input type="checkbox"/> Yes <input checked="" type="checkbox"/> No
Within the area overlying a subsurface mine. (Does not apply to below grade tanks) - Written confirmation or verification or map from the NM EMNRD-Mining and Mineral Division See Figure 4	<input type="checkbox"/> Yes <input checked="" type="checkbox"/> No
Within an unstable area. (Does not apply to below grade tanks) - Engineering measures incorporated into the design; NM Bureau of Geology & Mineral Resources; USGS; NM Geological Society; Topographic map See Figures 6, 8, 9, Appendix G	<input type="checkbox"/> Yes <input checked="" type="checkbox"/> No
Within a 100-year floodplain. (Does not apply to below grade tanks) - FEMA map See Figure 3	<input type="checkbox"/> Yes <input checked="" type="checkbox"/> No
Below Grade Tanks	
Within 100 feet of a continuously flowing watercourse, significant watercourse, lakebed, sinkhole, wetland or playa lake (measured from the ordinary high-water mark). - Topographic map; Visual inspection (certification) of the proposed site	<input type="checkbox"/> Yes <input type="checkbox"/> No
Within 200 horizontal feet of a spring or a fresh water well used for public or livestock consumption; - NM Office of the State Engineer - iWATERS database search; Visual inspection (certification) of the proposed site	<input type="checkbox"/> Yes <input type="checkbox"/> No
Temporary Pit using Low Chloride Drilling Fluid (maximum chloride content 15,000 mg/liter)	
Within 100 feet of a continuously flowing watercourse, or any other significant watercourse or within 200 feet of any lakebed, sinkhole, or playa lake (measured from the ordinary high-water mark). (Applies to low chloride temporary pits.) - Topographic map; Visual inspection (certification) of the proposed site	<input type="checkbox"/> Yes <input type="checkbox"/> No
Within 300 feet from a occupied permanent residence, school, hospital, institution, or church in existence at the time of initial application. - Visual inspection (certification) of the proposed site; Aerial photo; Satellite image	<input type="checkbox"/> Yes <input type="checkbox"/> No

Within 200 horizontal feet of a spring or a private, domestic fresh water well used by less than five households for domestic or stock watering purposes, or 300 feet of any other fresh water well or spring, in existence at the time of the initial application.
 NM Office of the State Engineer - iWATERS database search; Visual inspection (certification) of the proposed site

Yes No

Within 100 feet of a wetland.

- US Fish and Wildlife Wetland Identification map; Topographic map; Visual inspection (certification) of the proposed site

Yes No

Temporary Pit Non-low chloride drilling fluid

Within 300 feet of a continuously flowing watercourse, or any other significant watercourse, or within 200 feet of any lakebed, sinkhole, or playa lake (measured from the ordinary high-water mark).

- Topographic map; Visual inspection (certification) of the proposed site

Yes No

See Figure 6

Within 300 feet from a permanent residence, school, hospital, institution, or church in existence at the time of initial application.

- Visual inspection (certification) of the proposed site; Aerial photo; Satellite image

Yes No

See Figure 2

Within 500 horizontal feet of a spring or a private, domestic fresh water well used by less than five households for domestic or stock watering purposes, or 1000 feet of any other fresh water well or spring, in the existence at the time of the initial application;

- NM Office of the State Engineer - iWATERS database search; Visual inspection (certification) of the proposed site

Yes No

See Appendices A, B, and Figures 1 & 2

Within 300 feet of a wetland.

- US Fish and Wildlife Wetland Identification map; Topographic map; Visual inspection (certification) of the proposed site

Yes No

See Figures 2, 5, & 6

Permanent Pit or Multi-Well Fluid Management Pit

Within 300 feet of a continuously flowing watercourse, or 200 feet of any other significant watercourse, or lakebed, sinkhole, or playa lake (measured from the ordinary high-water mark).

- Topographic map; Visual inspection (certification) of the proposed site

Yes No

Within 1000 feet from a permanent residence, school, hospital, institution, or church in existence at the time of initial application.

- Visual inspection (certification) of the proposed site; Aerial photo; Satellite image

Yes No

Within 500 horizontal feet of a spring or a fresh water well used for domestic or stock watering purposes, in existence at the time of initial application.

- NM Office of the State Engineer - iWATERS database search; Visual inspection (certification) of the proposed site

Yes No

Within 500 feet of a wetland.

- US Fish and Wildlife Wetland Identification map; Topographic map; Visual inspection (certification) of the proposed site

Yes No

10.
Temporary Pits, Emergency Pits, and Below-grade Tanks Permit Application Attachment Checklist: Subsection B of 19.15.17.9 NMAC
Instructions: Each of the following items must be attached to the application. Please indicate, by a check mark in the box, that the documents are attached.

- Hydrogeologic Report (Below-grade Tanks) - based upon the requirements of Paragraph (4) of Subsection B of 19.15.17.9 NMAC
- Hydrogeologic Data (Temporary and Emergency Pits) - based upon the requirements of Paragraph (2) of Subsection B of 19.15.17.9 NMAC
See Appendix C
- Siting Criteria Compliance Demonstrations - based upon the appropriate requirements of 19.15.17.10 NMAC **Attached**
- Design Plan - based upon the appropriate requirements of 19.15.17.11 NMAC **See Appendix D**
- Operating and Maintenance Plan - based upon the appropriate requirements of 19.15.17.12 NMAC **See Appendix E**
- Closure Plan (Please complete Boxes 14 through 18, if applicable) - based upon the appropriate requirements of Subsection C of 19.15.17.9 NMAC and 19.15.17.13 NMAC **See Appendix F**
- Previously Approved Design (attach copy of design) API Number: _____ or Permit Number: _____

11.
Multi-Well Fluid Management Pit Checklist: Subsection B of 19.15.17.9 NMAC
Instructions: Each of the following items must be attached to the application. Please indicate, by a check mark in the box, that the documents are attached.

- Design Plan - based upon the appropriate requirements of 19.15.17.11 NMAC
- Operating and Maintenance Plan - based upon the appropriate requirements of 19.15.17.12 NMAC
- A List of wells with approved application for permit to drill associated with the pit.
- Closure Plan (Please complete Boxes 14 through 18, if applicable) - based upon the appropriate requirements of Subsection C of 19.15.17.9 NMAC and 19.15.17.13 NMAC
- Hydrogeologic Data - based upon the requirements of Paragraph (4) of Subsection B of 19.15.17.9 NMAC
- Siting Criteria Compliance Demonstrations - based upon the appropriate requirements of 19.15.17.10 NMAC

Previously Approved Design (attach copy of design) API Number: _____ or Permit Number: _____

12. **Permanent Pits Permit Application Checklist:** Subsection B of 19.15.17.9 NMAC

Instructions: Each of the following items must be attached to the application. Please indicate, by a check mark in the box, that the documents are attached.

- Hydrogeologic Report - based upon the requirements of Paragraph (1) of Subsection B of 19.15.17.9 NMAC
- Siting Criteria Compliance Demonstrations - based upon the appropriate requirements of 19.15.17.10 NMAC
- Climatological Factors Assessment
- Certified Engineering Design Plans - based upon the appropriate requirements of 19.15.17.11 NMAC
- Dike Protection and Structural Integrity Design - based upon the appropriate requirements of 19.15.17.11 NMAC
- Leak Detection Design - based upon the appropriate requirements of 19.15.17.11 NMAC
- Liner Specifications and Compatibility Assessment - based upon the appropriate requirements of 19.15.17.11 NMAC
- Quality Control/Quality Assurance Construction and Installation Plan
- Operating and Maintenance Plan - based upon the appropriate requirements of 19.15.17.12 NMAC
- Freeboard and Overtopping Prevention Plan - based upon the appropriate requirements of 19.15.17.11 NMAC
- Nuisance or Hazardous Odors, including H₂S, Prevention Plan
- Emergency Response Plan
- Oil Field Waste Stream Characterization
- Monitoring and Inspection Plan
- Erosion Control Plan
- Closure Plan - based upon the appropriate requirements of Subsection C of 19.15.17.9 NMAC and 19.15.17.13 NMAC

13. **Proposed Closure:** 19.15.17.13 NMAC **See Appendix F**

Instructions: Please complete the applicable boxes, Boxes 14 through 18, in regards to the proposed closure plan.

- Type: Drilling Workover Emergency Cavitation P&A Permanent Pit Below-grade Tank Multi-well Fluid Management Pit
 Alternative
- Proposed Closure Method: Waste Excavation and Removal
 Waste Removal (Closed-loop systems only)
 On-site Closure Method (Only for temporary pits and closed-loop systems)
 In-place Burial On-site Trench Burial
 Alternative Closure Method

14. **Waste Excavation and Removal Closure Plan Checklist:** (19.15.17.13 NMAC) **Instructions:** Each of the following items must be attached to the closure plan. Please indicate, by a check mark in the box, that the documents are attached.

- Protocols and Procedures - based upon the appropriate requirements of 19.15.17.13 NMAC
- Confirmation Sampling Plan (if applicable) - based upon the appropriate requirements of Subsection C of 19.15.17.13 NMAC
- Disposal Facility Name and Permit Number (for liquids, drilling fluids and drill cuttings)
- Soil Backfill and Cover Design Specifications - based upon the appropriate requirements of Subsection H of 19.15.17.13 NMAC
- Re-vegetation Plan - based upon the appropriate requirements of Subsection H of 19.15.17.13 NMAC
- Site Reclamation Plan - based upon the appropriate requirements of Subsection H of 19.15.17.13 NMAC

15. **Siting Criteria (regarding on-site closure methods only):** 19.15.17.10 NMAC

Instructions: Each siting criteria requires a demonstration of compliance in the closure plan. Recommendations of acceptable source material are provided below. Requests regarding changes to certain siting criteria require justifications and/or demonstrations of equivalency. Please refer to 19.15.17.10 NMAC for guidance.

- | | |
|---|--|
| Ground water is less than 25 feet below the bottom of the buried waste.
- NM Office of the State Engineer - iWATERS database search; USGS; Data obtained from nearby wells
See Appendices A & B, and Figure 7 | <input type="checkbox"/> Yes <input checked="" type="checkbox"/> No
<input type="checkbox"/> NA |
| Ground water is between 25-50 feet below the bottom of the buried waste
- NM Office of the State Engineer - iWATERS database search; USGS; Data obtained from nearby wells
See Appendices A & B, and Figure 7 | <input type="checkbox"/> Yes <input checked="" type="checkbox"/> No
<input type="checkbox"/> NA |
| Ground water is more than 100 feet below the bottom of the buried waste.
- NM Office of the State Engineer - iWATERS database search; USGS; Data obtained from nearby wells
See Appendices A & B, and Figure 7 | <input checked="" type="checkbox"/> Yes <input type="checkbox"/> No
<input type="checkbox"/> NA |
| Within 100 feet of a continuously flowing watercourse, or 200 feet of any other significant watercourse, lakebed, sinkhole, or playa lake (measured from the ordinary high-water mark).
- Topographic map; Visual inspection (certification) of the proposed site
See Figure 6 | <input type="checkbox"/> Yes <input checked="" type="checkbox"/> No |
| Within 300 feet from a permanent residence, school, hospital, institution, or church in existence at the time of initial application.
- Visual inspection (certification) of the proposed site; Aerial photo; Satellite image
See Figure 2 | <input type="checkbox"/> Yes <input checked="" type="checkbox"/> No |
| Within 300 horizontal feet of a private, domestic fresh water well or spring used for domestic or stock watering purposes, in existence at the time of initial application. | <input type="checkbox"/> Yes <input checked="" type="checkbox"/> No |

<p>- NM Office of the State Engineer - iWATERS database; Visual inspection (certification) of the proposed site See Appendices A & B, and Figure 7</p> <p>Written confirmation or verification from the municipality; Written approval obtained from the municipality <input type="checkbox"/> Yes <input checked="" type="checkbox"/> No</p> <p>Within 300 feet of a wetland. US Fish and Wildlife Wetland Identification map; Topographic map; Visual inspection (certification) of the proposed site See Figures 2, 5 & 6 <input type="checkbox"/> Yes <input checked="" type="checkbox"/> No</p> <p>Within incorporated municipal boundaries or within a defined municipal fresh water well field covered under a municipal ordinance adopted pursuant to NMSA 1978, Section 3-27-3, as amended. <input type="checkbox"/> Yes <input checked="" type="checkbox"/> No</p> <p>- Written confirmation or verification from the municipality; Written approval obtained from the municipality See Figure 2</p> <p>Within the area overlying a subsurface mine. <input type="checkbox"/> Yes <input checked="" type="checkbox"/> No</p> <p>- Written confirmation or verification or map from the NM EMNRD-Mining and Mineral Division See Figure 4</p> <p>Within an unstable area. <input type="checkbox"/> Yes <input checked="" type="checkbox"/> No</p> <p>- Engineering measures incorporated into the design; NM Bureau of Geology & Mineral Resources; USGS; NM Geological Society; Topographic map See Figures 6, 8, & 9, Appendix G</p> <p>Within a 100-year floodplain. <input type="checkbox"/> Yes <input checked="" type="checkbox"/> No</p> <p>- FEMA map See Figure 3</p>

16.
On-Site Closure Plan Checklist: (19.15.17.13 NMAC) *Instructions: Each of the following items must be attached to the closure plan. Please indicate, by a check mark in the box, that the documents are attached.*

- Siting Criteria Compliance Demonstrations - based upon the appropriate requirements of 19.15.17.10 NMAC **Attached**
- Proof of Surface Owner Notice - based upon the appropriate requirements of Subsection E of 19.15.17.13 NMAC
- Construction/Design Plan of Burial Trench (if applicable) based upon the appropriate requirements of Subsection K of 19.15.17.11 NMAC
- Construction/Design Plan of Temporary Pit (for in-place burial of a drying pad) - based upon the appropriate requirements of 19.15.17.11 NMAC
See Appendix D
- Protocols and Procedures - based upon the appropriate requirements of 19.15.17.13 NMAC **See Appendix F**
- Confirmation Sampling Plan (if applicable) - based upon the appropriate requirements of 19.15.17.13 NMAC **See Appendix F**
- Waste Material Sampling Plan - based upon the appropriate requirements of 19.15.17.13 NMAC **See Appendix F**
- Disposal Facility Name and Permit Number (for liquids, drilling fluids and drill cuttings or in case on-site closure standards cannot be achieved)
See Appendix F
- Soil Cover Design - based upon the appropriate requirements of Subsection H of 19.15.17.13 NMAC **See Appendix F**
- Re-vegetation Plan - based upon the appropriate requirements of Subsection H of 19.15.17.13 NMAC **See Appendix F**
- Site Reclamation Plan - based upon the appropriate requirements of Subsection H of 19.15.17.13 NMAC **See Appendix F**

17.
Operator Application Certification:
I hereby certify that the information submitted with this application is true, accurate and complete to the best of my knowledge and belief.

Name (Print): Adriane Kenney Title: Environmental Specialist

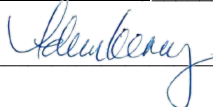
Signature:  Date: 02/16/2026

e-mail address: akenney@chevron.com Telephone: 832-854-5620

18.
OCD Approval: Permit Application (including closure plan) Closure Plan (only) OCD Conditions (see attachment)

OCD Representative Signature: Joel Stone Approval Date: 03/03/2026

Title: Senior Environmental Scientist OCD Permit Number: FJZS2606258391

19.
Closure Report (required within 60 days of closure completion): 19.15.17.13 NMAC
Instructions: Operators are required to obtain an approved closure plan prior to implementing any closure activities and submitting the closure report. The closure report is required to be submitted to the division within 60 days of the completion of the closure activities. Please do not complete this section of the form until an approved closure plan has been obtained and the closure activities have been completed.

Closure Completion Date: _____

20.
Closure Method:

Waste Excavation and Removal On-Site Closure Method Alternative Closure Method Waste Removal (Closed-loop systems only)

If different from approved plan, please explain.

21.

Closure Report Attachment Checklist: *Instructions: Each of the following items must be attached to the closure report. Please indicate, by a check mark in the box, that the documents are attached.*

- Proof of Closure Notice (surface owner and division)
- Proof of Deed Notice (required for on-site closure for private land only)
- Plot Plan (for on-site closures and temporary pits)
- Confirmation Sampling Analytical Results (if applicable)
- Waste Material Sampling Analytical Results (required for on-site closure)
- Disposal Facility Name and Permit Number
- Soil Backfilling and Cover Installation
- Re-vegetation Application Rates and Seeding Technique
- Site Reclamation (Photo Documentation)

On-site Closure Location: Latitude _____ Longitude _____ NAD: 1927 1983

22.

Operator Closure Certification:

I hereby certify that the information and attachments submitted with this closure report is true, accurate and complete to the best of my knowledge and belief. I also certify that the closure complies with all applicable closure requirements and conditions specified in the approved closure plan.

Name (Print): _____ Title: _____

Signature: _____ Date: _____

e-mail address: _____ Telephone: _____

Siting Criteria Demonstration (19.15.17.10 NMAC)

**ZN 34 3 FED COM (Pad 13) Temporary Pit
Section 34 of T23S, R34E, Lea County**

Siting Criteria Demonstration ZN 34 3 FED COM (Pad 13) Temporary Pit

Depth to Groundwater, 19.15.17.10.3(a)

Figure 7, Appendices A & B, and the discussion presented below demonstrate that the depth to groundwater within the broader area of the proposed site ranges from 40 to 475 feet near the proposed temporary pit.

Figure 7 depicts the location of the pit relative to the locations of water wells within 5 miles of the pit for which water level data are available. The average depths to water for wells shown on **Figure 7** are contained in **Appendix B**. Relatively thin strata of the Pecos River Basin alluvial aquifer is mapped beneath the site by the USGS (**Figure 7**) but the alluvial aquifer in this area has very low productivity in terms of well yields. Water well data, including gauging dates for the USGS data, are detailed in **Appendix A** (USGS) and **Appendix B** (NMOSE). No active USGS-gauged water wells are located within 5 miles of the proposed temporary pit location, but several are located in the immediately surrounding area. Water levels in these wells range from 40 feet to 475 feet in historical data from the inactive USGS wells found within 5 miles and active wells outside of the 5 mile search radius. The USGS National Hydrography Dataset (NHD) (**Figure 6**) and the USGS San Simon Sink 7.5-minute topographic quadrangle (updated in 2020) show standing water at the bottom of the San Simon Sink, about 3.5 miles from the proposed temporary pit location. Assuming the elevation of the water is representative of the water table, the depth to water beneath the proposed pit is estimated to be approximately 150 feet.

Fifty four water wells located within 5 miles of the temporary pit were gauged by NMOSE with reported water levels ranging from 20 ft bgs (approximately 4.8 northwest of the site) to 730 bgs (approximately 4.8 miles northeast of the site).

The proposed temporary pit area and vicinity are underlain by recent eolian deposits consisting of drift sand a few feet in thickness and local occurrences of sand dunes (**Figure 9**). The eolian deposits are underlain by Pleistocene to recent alluvial deposits consisting of unconsolidated to partially consolidated sand, silt, gravel, clay and caliche. Alluvium thickness in this area appears to be approximately 100 feet or less. Triassic Dockum strata underlie the alluvium deposits and its thickness appears to be approximately 500 feet or more. The Dockum Group has been divided into three formations: lower red shale, siltstone, and very fine-grained sandstone called the Tecovas Formation (or Pierce Canyon redbeds); middle reddish-brown and gray sandstone called the Santa Rosa sandstone; and upper brick-red to maroon and purple shale with thin beds of fine red or gray sandstone and siltstone called the Chinle Formation.

Proximity to Surface Water, 19.15.17.10.3(b)

Figure 6 shows USGS elevation contour lines and the USGS NHD. The map demonstrates that the location is not within 1,000 feet of a continuously flowing waterway course, any other significant watercourse or lakebed, sinkhole, or playa lake.

- The nearest surface water feature (Pecos River) is approximately 20 miles west of the pit location.
- There are NHD features (ephemeral) approximately 0.6 miles northeast of the pit location.

Proximity to Occupied Residences, Schools, Hospitals, Institutions or Churches, 19.15.17.10.3(c)

The ESRI aerial imagery in **Figure 2** demonstrates that the location is not within 300 feet of occupied residences, schools, hospitals, institutions or churches.

- There are no structures within 1,000 feet of the pit location.

Proximity to springs and/or Domestic Freshwater Wells 19.15.17.10.3(d)

No springs or domestic freshwater wells have been mapped within 300 ft of the pit locations.

Proximity to Incorporated Municipal Boundaries and Fresh Water Well Fields 19.15.17.10.3(e)

Figure 1 demonstrates that the location is not within incorporated municipal boundaries or defined municipal fresh water well fields covered under a municipal ordinance adopted pursuant to NMSA 1978, Section 3-27-3, as amended.

- The closest municipality is the city of Malaga, approximately 18 miles to the west.

Proximity to Wetlands, 19.15.17.10.3(f)

Utilizing USFWS wetland data, **Figure 5** demonstrates that the proposed location is not located within 300 feet of a wetland.

Proximity to Subsurface Mines, 19.15.17.10.3(g)

Analysis of aerial imagery in the vicinity of the proposed temporary pit show that the nearest mines are all surficial caliche pits. There are no subsurface mines in the area as indicated in **Figure 4**.

Proximity to Unstable Area, 19.15.17.10.3(h)

Figure 8 identifies the location of the proposed temporary pit with respect to Bureau of Land Management (BLM) mapped potential karst areas. The proposed Temporary Pit is

mapped in a “Low Potential” karst area. The area lies near the northeast margin of the Delaware Basin. Bedrock cropping out beneath the proposed project area is comprised of the Triassic-aged Dockum Group. Underlying the Dockum Group are the Dewey Lake redbeds. Both of these formations are composed chiefly of clastic (insoluble), non-karst-forming rocks. Beneath these formations are Permian-aged rocks of the Rustler and Salado Formations. These rocks contain significant beds of halite (i.e., rock salt) and anhydrite, making them susceptible to karst formation. The top of the Rustler Formation in the proposed project area is approximately 800 feet below the land surface (Crowl et al. 2011¹). Therefore, local karst potential is likely to be low. An Evaluation of Unstable Conditions is presented in Appendix G.

In the unlikely event that a void occurs during construction or operation activities, all activities must stop immediately, and the BLM should then be contacted within 24 hours to devise the best management plan to protect the environment and human safety.

Proximity to Floodplains, 19.15.17.10.3(i)

The location is within an area mapped by the Federal Emergency Management Agency (FEMA) as an area of minimal flood hazard (**Figure 3**).



¹ Crowl, W. J., D. E. Hulse, and G. Tucker, P.E., 2011. NI 43-101 Technical Report Prefeasibility Study for the Ochoa Project, Lea County, New Mexico. Prepared for IC Potash Corporation by Gustavsen and Associates, December 30, 2011, 301 p.

Site Specific Information, Figures 1-11

**ZN 34 3 FED COM (Pad 13) Temporary Pit
Section 34 of T23S, R34E, Lea County**

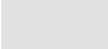

LEGEND

-  Proposed Temporary Pit
-  1,000 ft Buffer
-  Townships

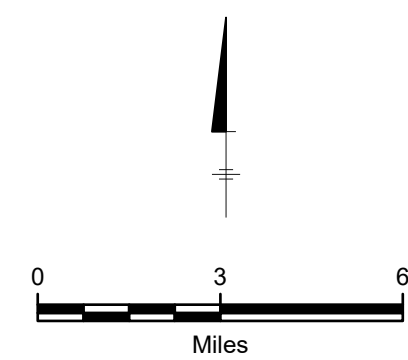

CHEVRON U.S.A. INC.
 ZION DEVELOPMENT AREA
 LEA COUNTY, NEW MEXICO
 PAD 13
 PROPOSED TEMPORARY RESERVE PIT

VICINITY MAP



FIGURE
1

DIV/GRP: ENV/IMDY DB: yadav0264.LD: PIC: PM: TM: DATE: 9/18/2025 4:23 PM
 PROJECT: PATH: T:_ENV\Chevron_MCBU\p\o\com\C144\Figures\Zion Pad 13.aprx

Bureau of Land Management, Texas Parks & Wildlife, Esri, HERE, Garmin, INCREMENT P, USGS, METI/NASA, NGA, EPA, USDA

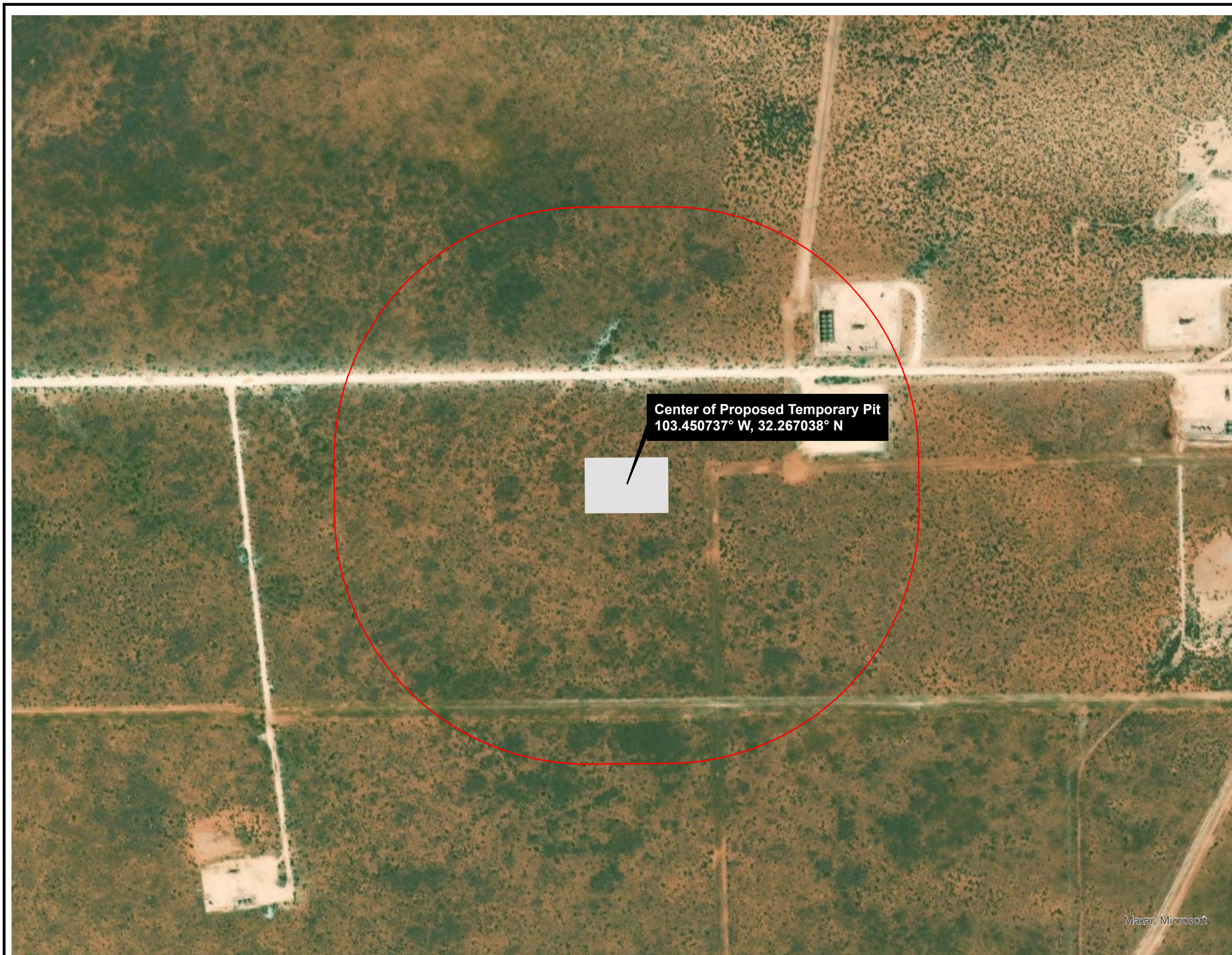

LEGEND

- Proposed Temporary Pit
- 1,000 ft Buffer

Center of Proposed Temporary Pit
 103.450737° W, 32.267038° N

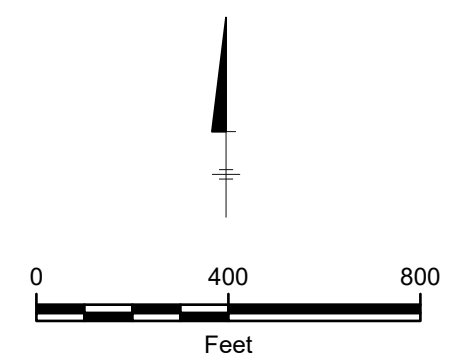

CHEVRON U.S.A. INC.
 ZION DEVELOPMENT AREA
 LEA COUNTY, NEW MEXICO
 PAD 13
 PROPOSED TEMPORARY RESERVE PIT

SITE OVERVIEW

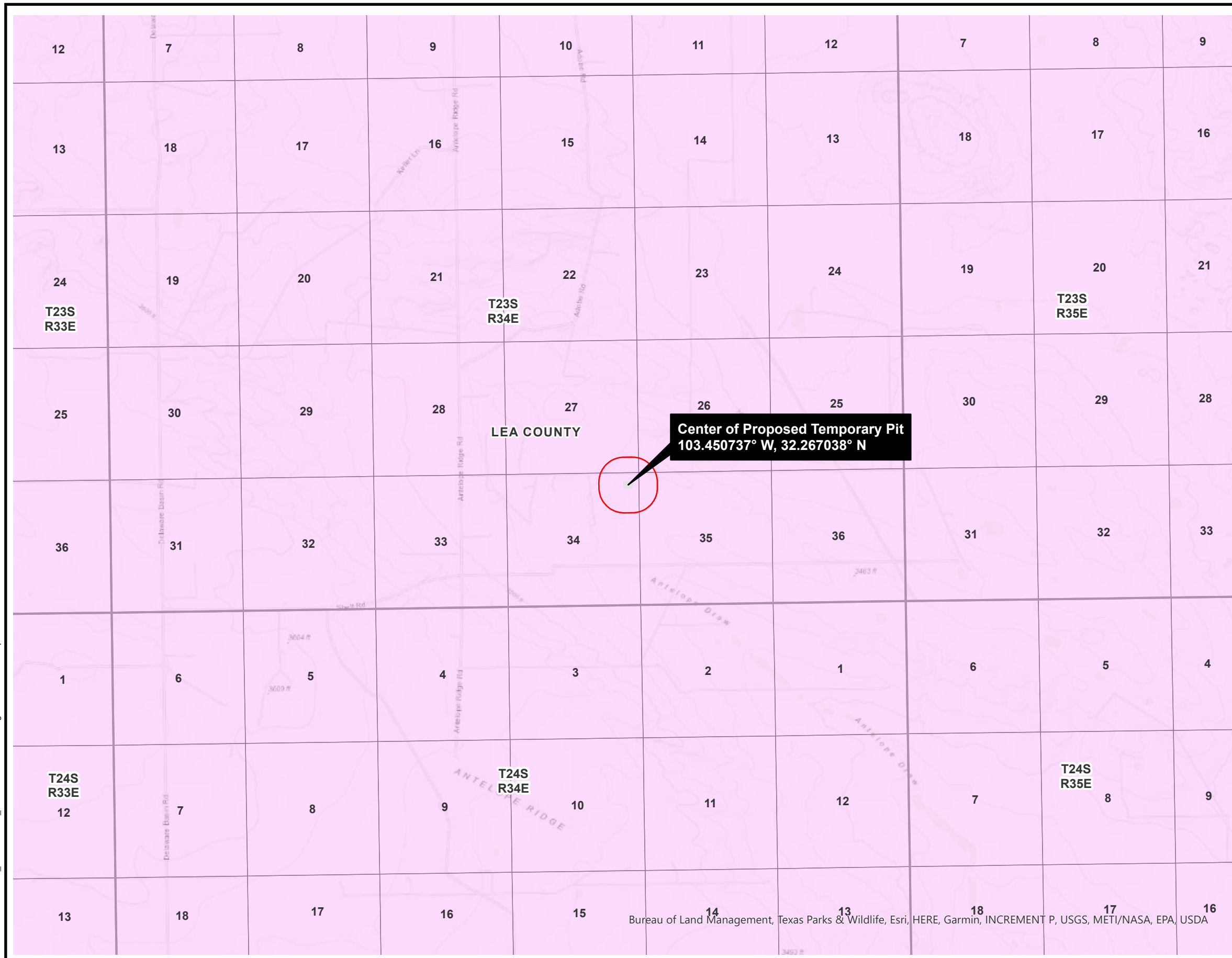

FIGURE
2





DIV/GRP: ENV/IMDV DB: yadav0264 LD: PIC: PM: TM:
 PROJECT: PATH: T:_ENV\Chevron_MCBU\Pro\ Zion Pad 13.aprx DATE: 9/18/2025 4:23 PM

Maxar, Microsoft

DIV/GRP: ENV/INDV DB: yadav0264.LD. PIC: PM. TM: DATE: 9/19/2025 12:35 PM
PROJECT: T:\ENV\Chevron_MCBU\proj\Zion\C144 Figures\Zion Pad 13.aprx

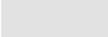

LEGEND

-  Proposed Temporary Pit
-  1,000 ft Buffer
-  Townships
-  Sections
- FEMA Floodplain**
-  Zone D

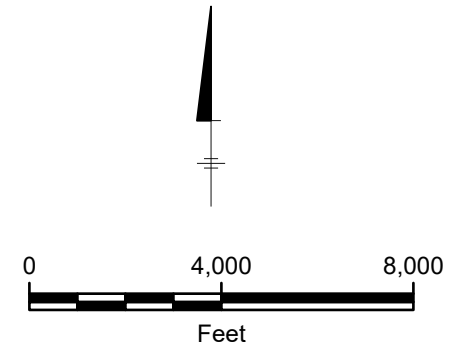

CHEVRON U.S.A. INC.
 ZION DEVELOPMENT AREA
 LEA COUNTY, NEW MEXICO
 PAD 13
 PROPOSED TEMPORARY RESERVE PIT

FLOODPLAIN MAP



FIGURE
3

Bureau of Land Management, Texas Parks & Wildlife, Esri, HERE, Garmin, INCREMENT P, USGS, METI/NASA, EPA, USDA

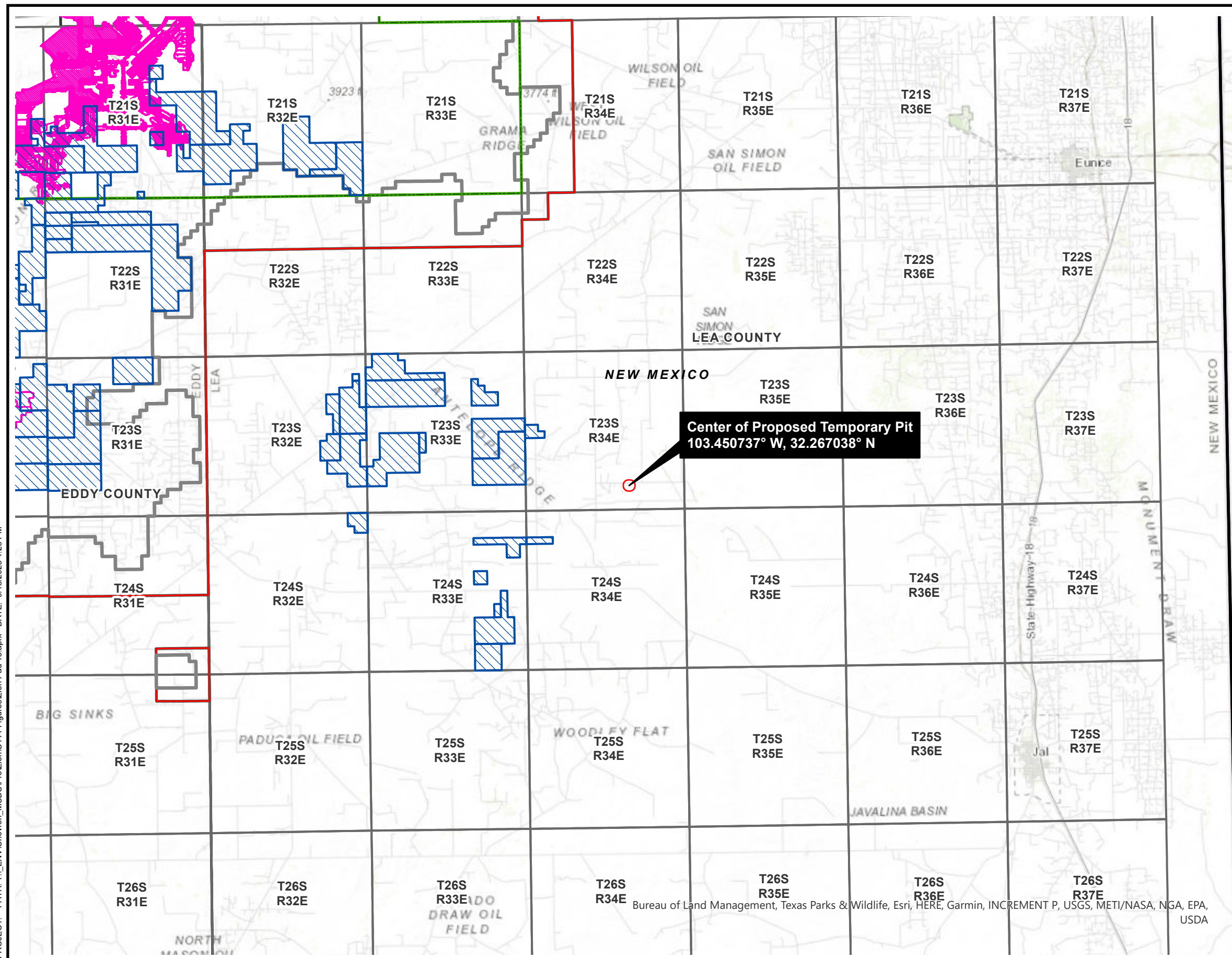

LEGEND

-  Mine Workings
-  Proposed Temporary Pit
-  1,000 ft Buffer
-  Potash Leases
-  Four String Casing Area
-  Known Potash Leasing Area
-  Schedule of Proposed Actions
-  Townships

Center of Proposed Temporary Pit
 103.450737° W, 32.267038° N

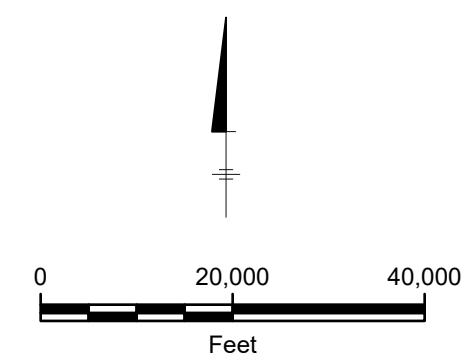

CHEVRON U.S.A. INC.
 ZION DEVELOPMENT AREA
 LEA COUNTY, NEW MEXICO
 PAD 13
 PROPOSED TEMPORARY RESERVE PIT

SUBSURFACE MINES - POTASH



FIGURE
4

DIV/GRP: ENV/IMDV DB: yadav0264.LD: PIC: PM: TM: DATE: 9/18/2025 4:23 PM
 PROJECT: T:\ENV\Chevron_MCBU\p\o\Zion Pad 13.aprx

Bureau of Land Management, Texas Parks & Wildlife, Esri, HERE, Garmin, INCREMENT P, USGS, METI/NASA, NGA, EPA, USDA

DIR/GROUP: ENV/IMDV DB: yadav0264 LD: PIC: PM: TM: DATE: 9/18/2025 4:23 PM
PROJECT: PATH: T:\ENV\Chevron_MCBU\Proj\Zion Pad 13.aprx



LEGEND

- Proposed Temporary Pit
- 1,000 ft Buffer
- Freshwater Emergent Wetland
- Freshwater Pond
- Riverine
- Townships
- Sections

Notes:
 1. USFWS - United States Fish and Wildlife Service
 2. NWI - National Wetlands Inventory

Data Source: BLM CFO. 2018. USFWS NWI.

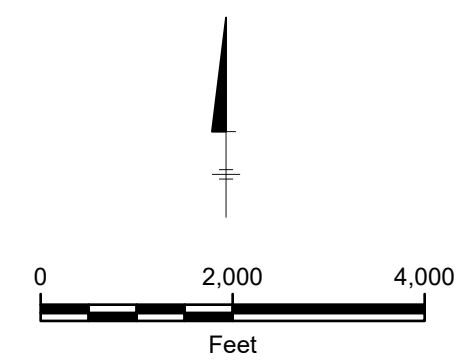

CHEVRON U.S.A. INC.
 ZION DEVELOPMENT AREA
 LEA COUNTY, NEW MEXICO
 PAD 13
 PROPOSED TEMPORARY RESERVE PIT

WETLANDS MAP



FIGURE
5



LEGEND

- 1,000 ft Buffer
- Proposed Temporary Pit
- USGS Contour Lines NM
- ArtificialPath
- StreamRiver
- LakePond
- Reservoir

Notes:
 1. USGS - United States Geological Survey
 2. NHD - National Hydrography Dataset

Data Source: BLM CFO. 2018. USGS NHD.

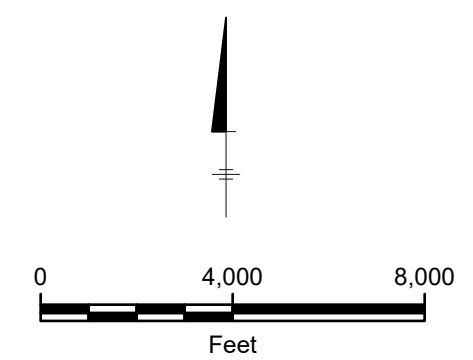

CHEVRON U.S.A. INC.
 ZION DEVELOPMENT AREA
 LEA COUNTY, NEW MEXICO
 PAD 13
 PROPOSED TEMPORARY RESERVE PIT

ELEVATION CONTOUR & NHD MAP



FIGURE
6

DIV/GRP: ENV/IMDV DB: yadav0264 LD: PIC: PM: TM:
 PROJECT: PATH: T:_ENV\Chevron_MCBU\p\o\Zion\C144 Figures\Zion Pad 13.aprx DATE: 9/18/2025 4:23 PM

DIV/GROUP: ENV/IMDV DB: yadav0264 LD: PIC: PM: TM: DATE: 9/18/2025 4:23 PM
PROJECT: PATH: T:\ENV\Chevron_MCBU\p\o\Zion\C144 Figures\Zion Pad 13.aprx

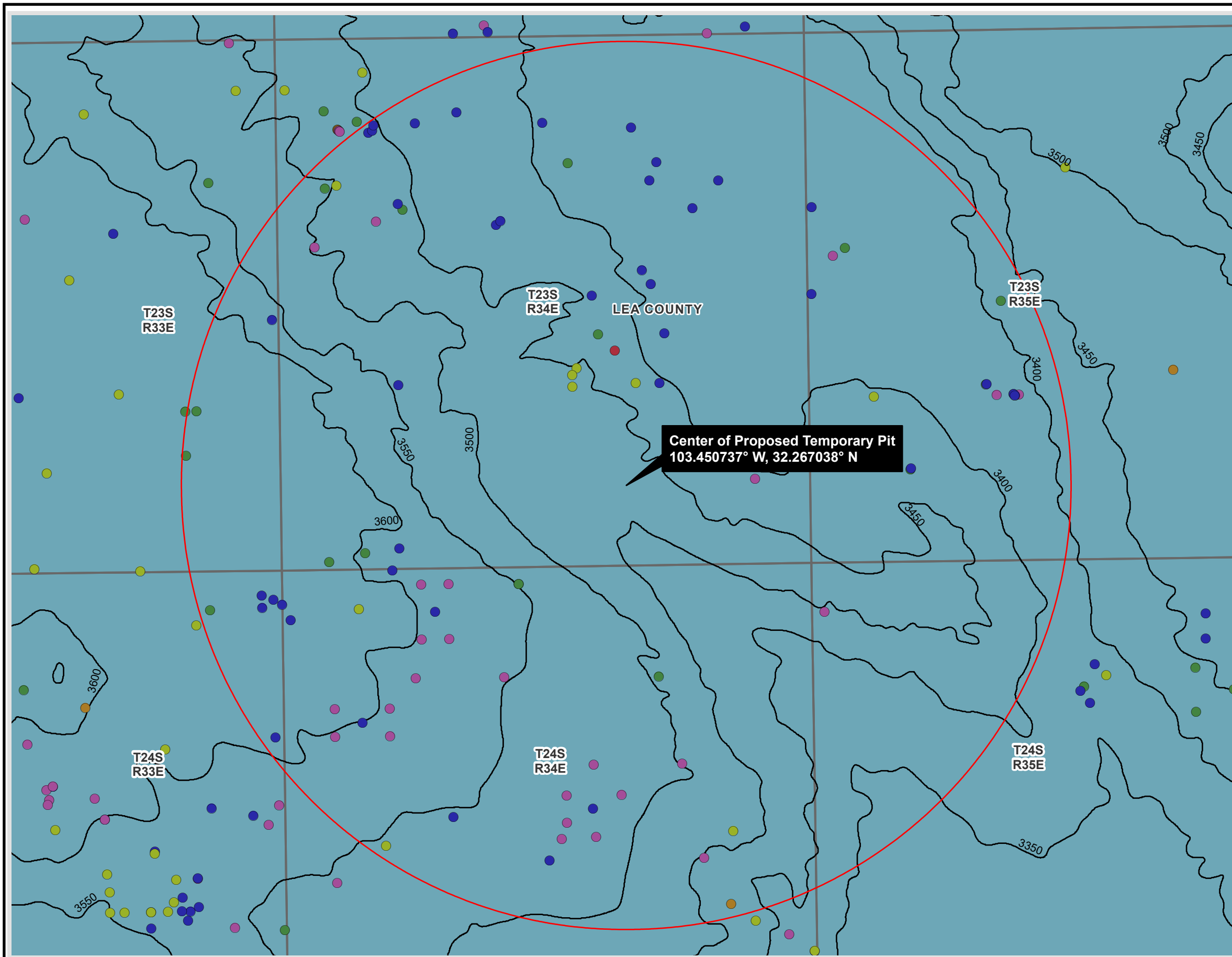

LEGEND

- USGS Contour Lines
- 5 Mile Buffer
- Townships
- OSE POD Wells**
 - Active
 - Inactive
 - Pending
 - Capped
 - Changed Location of Well
 - Plugged
 - Unknown
- Pecos River Basin Alluvial Aquifer

Notes:
 1. USGS - United States Geological Survey
 2. NMOSE - New Mexico Office of the State Engineer

Data Source: BLM CFO. 2018. USGS and NMOSE.

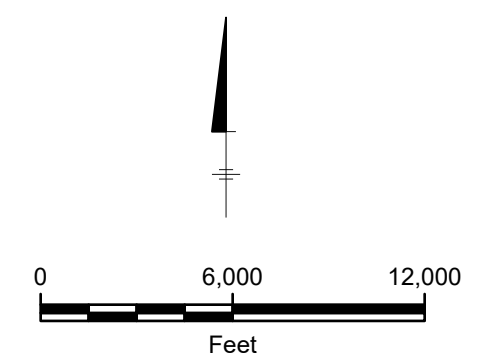

CHEVRON U.S.A. INC.
 ZION DEVELOPMENT AREA
 LEA COUNTY, NEW MEXICO
 PAD 13
 PROPOSED TEMPORARY RESERVE PIT

USGS AND NMOSE GROUNDWATER WELLS



FIGURE 7

DIR/GROUP: ENV/IMDV DB: yadav0264.LD. PIC: PM. TM: 9/19/2025 12:35 PM
PROJECT: PATH: T:\ENV\Chevron_MCBU\Proj\Zion Pad 13.aprx DATE: 9/19/2025 12:35 PM

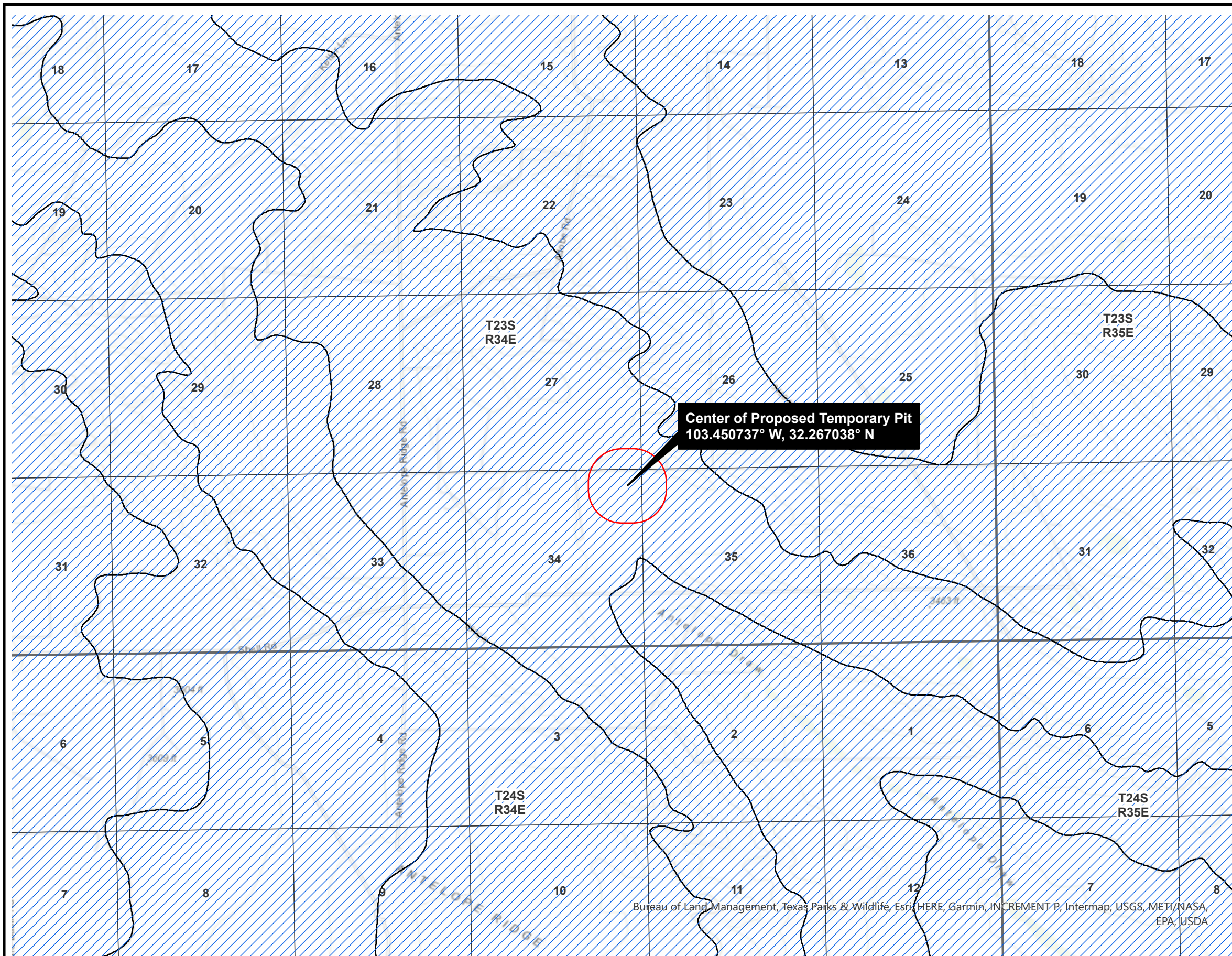

LEGEND

- USGS Contour Lines NM
- 1,000 ft Buffer
- Townships
- Sections

Karst Occurrence Potential

- Low

Center of Proposed Temporary Pit
103.450737° W, 32.267038° N

0 3,000 6,000
Feet

CHEVRON U.S.A. INC.
ZION DEVELOPMENT AREA
LEA COUNTY, NEW MEXICO
PAD 13
PROPOSED TEMPORARY RESERVE PIT

KARST POTENTIAL

Bureau of Land Management, Texas Parks & Wildlife, Esri, HERE, Garmin, INCREMENT P, Intermap, USGS, METI/NASA, EPA, USDA

ARCADIS

FIGURE
8

DIR/GROUP: ENV/IMDV DB: yadav0264 LD: PIC: PM: TM:
PROJECT: PATH: T:_ENV\Chevron_MCBU\Proj\Zion\144 Figures\Zion Pad 13.aprx DATE: 9/19/2025 12:35 PM

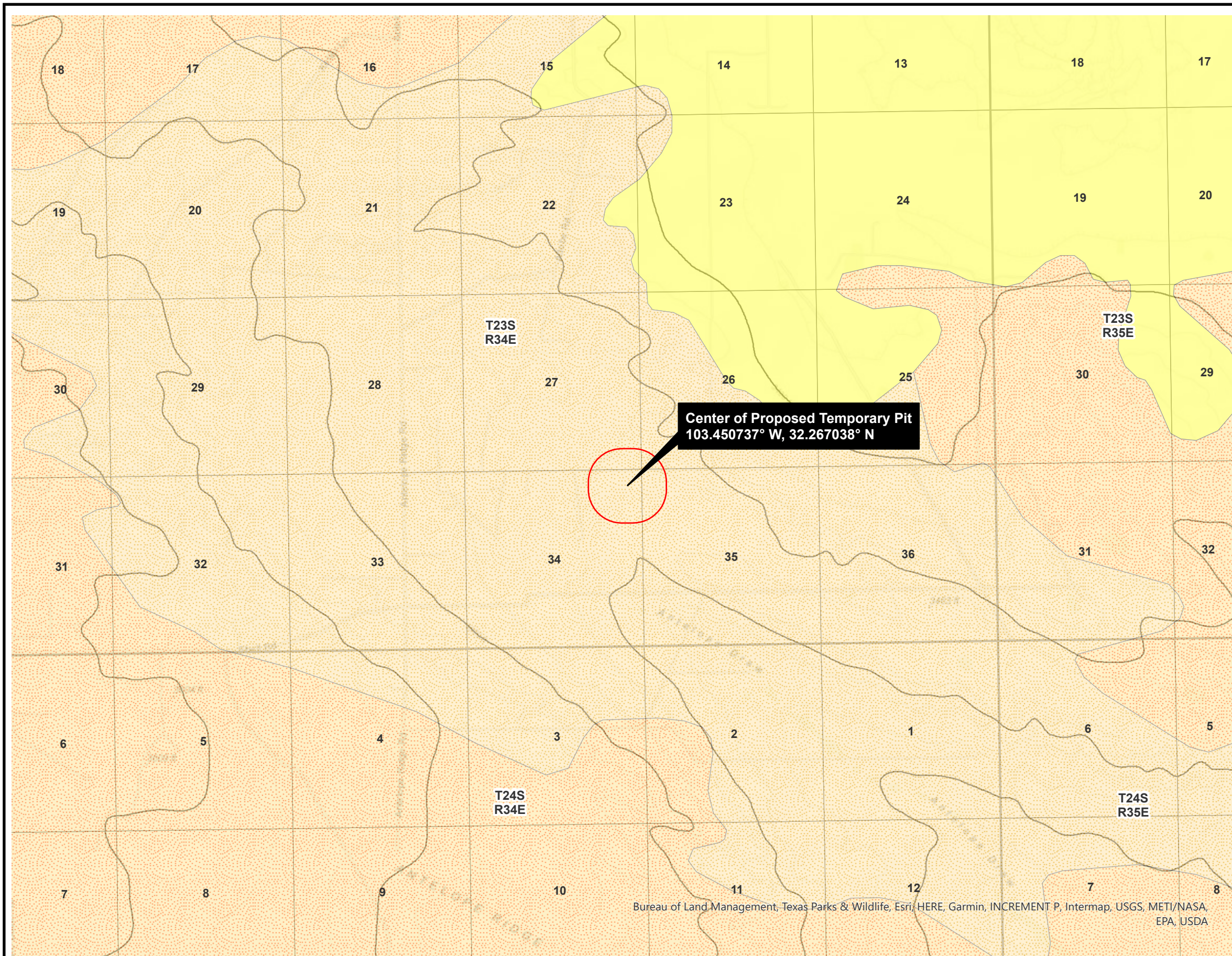

LEGEND

- USGS Contour Lines NM
- 1,000 ft Buffer
- Townships
- Sections

Aquifer

-

Geology

- Qe/Qp
- Qoa
- Qp

Qe: Quaternary Eolian Deposits
 Qp: Quaternary Piedmont Deposits
 Qoa: Quaternary Older alluvial deposits

0 3,000 6,000
 Feet

CHEVRON U.S.A. INC.
 ZION DEVELOPMENT AREA
 LEA COUNTY, NEW MEXICO
 PAD 13
 PROPOSED TEMPORARY RESERVE PIT

LOCAL GEOLOGY

ARCADIS

FIGURE
9

Bureau of Land Management, Texas Parks & Wildlife, Esri, HERE, Garmin, INCREMENT P, Intermap, USGS, METI/NASA, EPA, USDA

DIV/GRP: ENV/IMDV DB: yadav0264 LD: PIC: PM: TM: PROJECT: PATH: T:\ENV\Chevron_MCBU\Proj\Zion\C144 Figures\Zion Pad 13.aprx DATE: 9/18/2025 4:23 PM

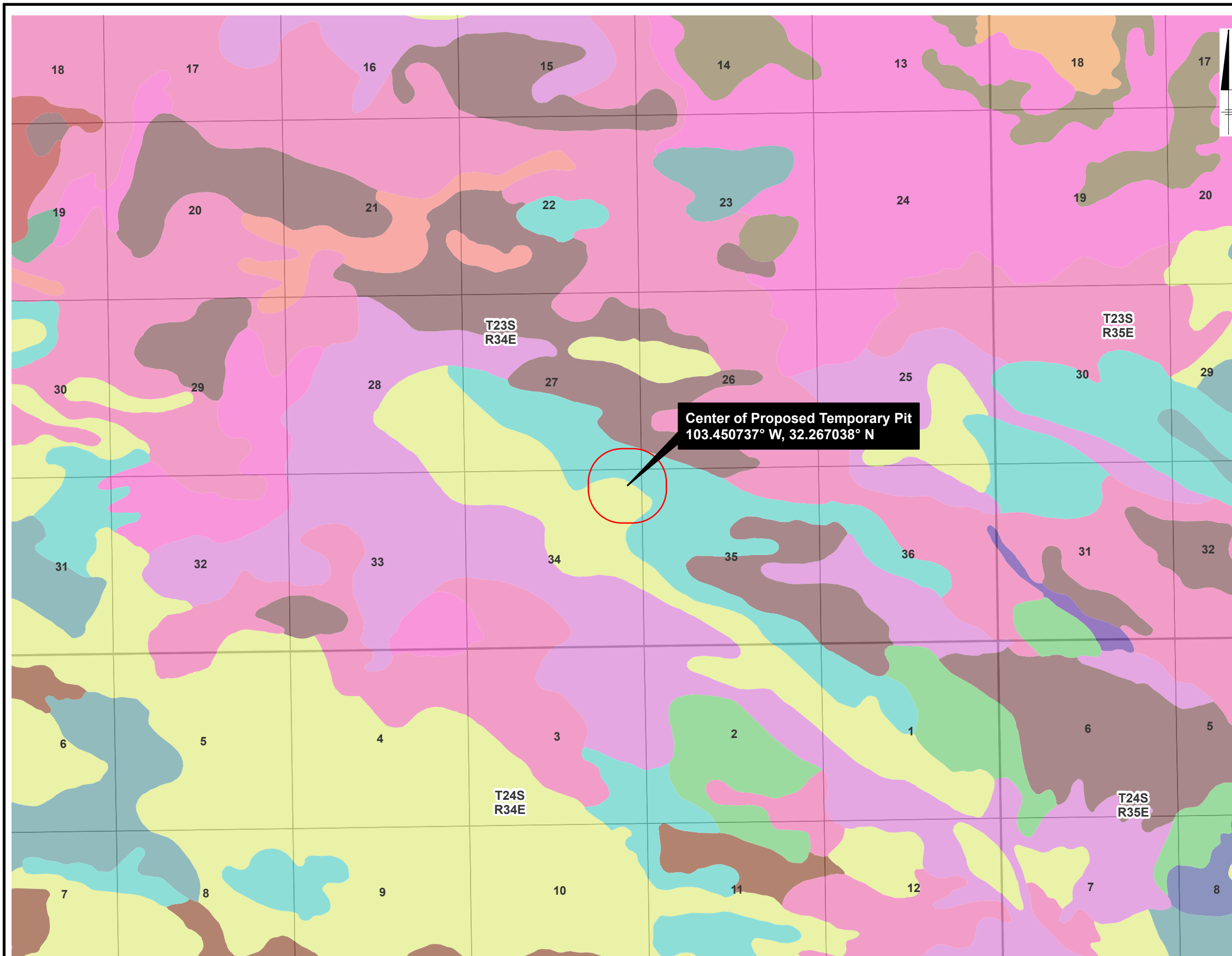

LEGEND

- 1,000 ft Buffer
 - Townships
 - Sections
- Lea County Soil Data**
- BD: Badland
 - BE: Berino-Cacique loamy fine sands association
 - BF: Berino-Cacique fine sandy loams association
 - BH: Berino-Cacique association, hummocky
 - CLP: Caliche pit
 - JA: Jal association
 - KO: Kimbrough gravelly loam, 0 to 3 percent slopes
 - LP: Largo-Pajarito complex
 - MN: Midessa and wink fine sandy loams
 - MU: Mixed alluvial land
 - MW: Mobeetie-Potter association, 1 to 15 percent slopes
 - PU: Pyote and maljamar fine sands
 - PY: Pyote soils and dune land
 - SE: Simona fine sandy loam, 0 to 3 percent slopes
 - SR: Simona-Upton association
 - SY: Stony rolling land
 - TF: Tonuco loamy fine sand

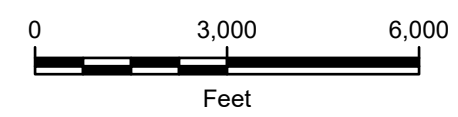

CHEVRON U.S.A. INC.
 ZION DEVELOPMENT AREA
 LEA COUNTY, NEW MEXICO
 PAD 13
 PROPOSED TEMPORARY RESERVE PIT

SOILS



FIGURE
10

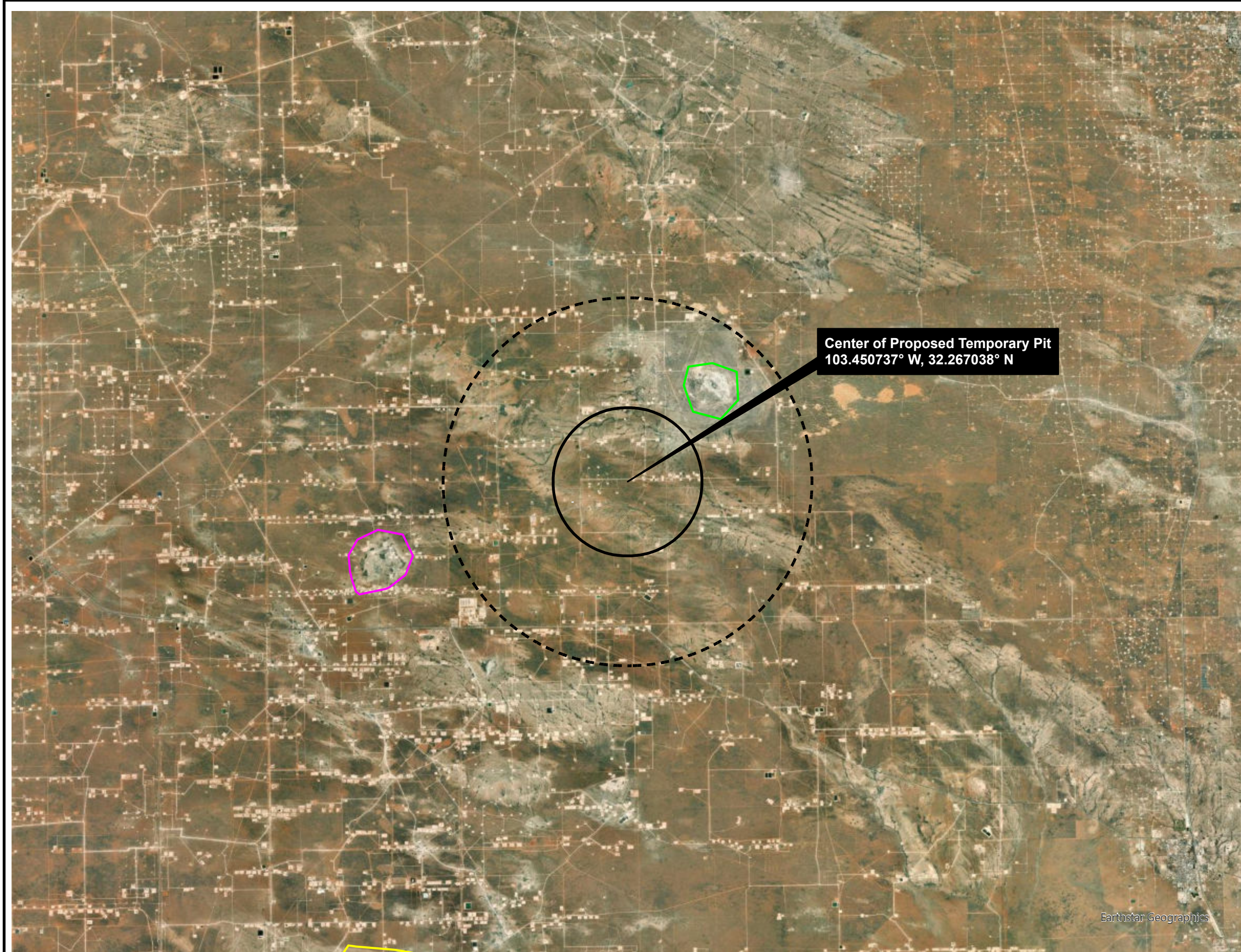

LEGEND

- Proposed Temporary Pit
- San Simon Sink
- Bell Lake Sink
- Area with Multiple Small Depressions
- 2 Mile Buffer
- 5 Mile Buffer

Center of Proposed Temporary Pit
 103.450737° W, 32.267038° N

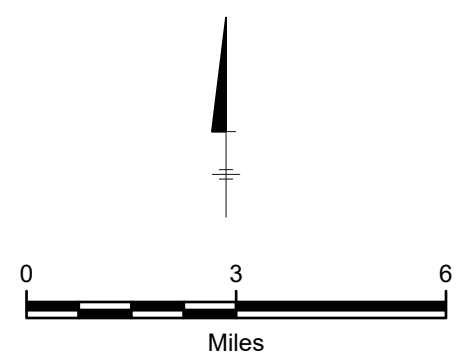

CHEVRON U.S.A. INC.
 ZION DEVELOPMENT AREA
 LEA COUNTY, NEW MEXICO
 PAD 13
 PROPOSED TEMPORARY RESERVE PIT
**AERIAL IMAGERY OF
 DISSOLUTION FEATURES**



FIGURE
11

DIV/GRP: ENV/IMDV DB: yadav0264 LD: PIC: PM: TM:
 PROJECT: PATH: T:_ENV\Chevron_MCBU\p\o\Zion\C144 Figures\Zion Pad 13.aprx DATE: 9/19/2025 12:34 PM

Earthstar Geographics

Variance Requests

**ZN 34 3 FED COM (Pad 13) Temporary Pit
Section 34 of T23S, R34E, Lea County**

Variance Requests

ZN 34 3 FED COM (Pad 13) Temporary Pit

Variance Request 1 of 2 – Extension of Closure Timeline for Temporary Pit

Reason for the requested variance

The Operator wishes to standardize closure practices and procedures across all active development areas where Temporary Pits are used. A closure timeline extension allows for improved flexibility in managing closure operations and would improve efficiency by allowing the closure of multiple pits during a single campaign.

The closure timeline is stated with the definition of a Temporary Pit, in that a pit *“must be closed within six months from the date the operator releases the drilling or workover rig from the first well using the pit”*.

For purposes of this variance, the Operator proposes a timeline based on the date of the first occurrence of Rig Down Move Out (RDMO). RDMO is defined as the activity when the drilling rig is moved off location. Typically, RDMO occurs after the completion of drilling the last well on the pad. On pads where the Operator plans to return to the pad, multiple RDMO dates occur. This variance does not consider subsequent RDMO affecting the closure timeline dates after the first RDMO. The Operator proposes dewatering the pit within 30 days of RDMO and proposes closing the pits within 1 year of RDMO.

The Operator uses a batch drilling process for drilling multiple wells on a single pad. The common procedure is to drill all the surface hole sections first followed by intermediate hole sections and finally production hole sections. The drilling rig skid moves to the next well without performing rig down activities when batch drilling. For the proposed four-well pad, the rig drills surfaces in the order of wells one to four, then intermediates in the order of wells four to one, and finally productions in the order of one to four. Note that specific orders may change based off well design and location specific factors, but the process of skidding and batch drilling is consistent throughout.

If the Operator ceases operations before drilling is complete and the rig is moved off the pad location, this constitutes a RDMO date and the 1-year closure criteria is based off the earliest RDMO date.

The Operator may utilize a shallow rig for drilling of only the surface and/or intermediate hole sections, if permitted to do so. The rig down and move out of the shallow rig does not constitute an RDMO date if the larger rig intending to drill production holes arrives within 3 months.

Demonstration that the variance will provide equal or better protection of fresh water, public health, and the environment.

In order to uphold the Operator's commitment to people and the environment, the following assurances will be provided in excess of the baseline requirements of 19.15.17 NMAC.

- The Operator will dewater the Temporary Pit within 30 days after RDMO.
- The Operator will utilize a 40-mil HDPE liner, as proposed in **Variance 2**.
- No fluid will be stored in the pit for any purpose after the completion of drilling activities other than in the event of emergency actions as described in 19.15.17.14 NMAC.
- The pits will be visually inspected on a weekly basis between RDMO and closure.
- If fluid is seen in the pit during inspection, then the Operator will mobilize equipment to have the pits drained within 7 days.
- The operator will maintain a fence around the perimeter of the pits and ensure it remains in good repair until closure.

Variance Request 2 of 2 – Proposed Use of High-Density Polyethylene (HDPE) Liner for Temporary Pit in lieu of Linear Low-Density Polyethylene (LLDPE) Liner

Memorandum

To: New Mexico Oil Conservation Division (NMOCD)

From: Chevron MCBU - Facilities Engineering Group

Subject: Variance Request for Use of HDPE Liner Material for Temporary Reserve Pits in New Mexico

Date: 7/23/2020

Chevron requests a variance to NMAC 19.15.17.11 (F) for use of high-density polyethylene (HDPE) geomembrane for the lining of temporary drilling reserve pits. HDPE is a preferred material which Chevron will install during drilling reserve pit construction. Chevron will utilize an HDPE geomembrane which offers equal or better performance than a typically available 20-mil string reinforced linear low-density polyethylene (LLDPE) material detailed in 19.15.17.11 (F), NMAC. An HDPE liner of equivalent thickness or greater than the 20-mil LLDPE will be installed. The following are considered in the design for implementation of the HDPE material to ensure the product is an equivalent, to the LLDPE material described, for temporary reserve drilling pits in New Mexico.

- An HDPE liner that has a thickness of less than 30-mils will be installed in a reserve pit as a shop-fabricated, extruded liner, and will not be field welded. Only HDPE liners of 30-mils in thickness or greater will be field welded for use in the temporary reserve pits.
- HDPE has lower permeability compared to LLDPE. This provides high barrier protection for soils during drilling operations and usage of the pits.
- HDPE may be installed with an underlying geotextile or similar material to provide additional protection from puncture or stress cracking. The subgrade for the liner system will be screened of deleterious materials and rocks and will be suitable for the liner installation. The use of geotextile or similar material will be evaluated on a specific case-by-case basis by Chevron.
- The HDPE liner used in Chevron's temporary reserve pits will have an equivalent or higher tear resistance and puncture resistance than that of a typical 20-mil string reinforced liner.
- HDPE material properties and liner has improved UV resistance to degradation when compared to LLDPE. This allows for extended life and improved long-term durability in pit liner applications.

All requirements for temporary pits' design and construction will be met in accordance with NMAC 19.15.17.11 and liner compatibility will comply with EPA SW-846 Method 9090A. Any requirements that may not be able to be adequately addressed, will be addressed under a separate variance request on a case-by-case basis.

Disclaimer: Tetra Tech, Inc. has not evaluated the full design of temporary reserve pits for Chevron and is not involved in the construction or operation of Chevron's lined, temporary reserve pits. Chevron understands that they will ensure that specific pit designs meet the criteria and intent of the NMAC and applicable codes for each pit location and construction.



7/23/2020
Nathan Langford, P.E.
Tetra Tech, Inc.



TECHNICAL DATA SHEET

HDPE Series, 40 mils

Black, Smooth

Tel: (450) 929-1234 Sales: (450) 929-2544 Toll free in North America: 1-800-571-3904 www.Solmax.com www.solmax.com

PROPERTY	TEST METHOD	FREQUENCY ⁽¹⁾	UNIT Imperial	
SPECIFICATIONS				
Thickness (min. avg.)	ASTM D5199	Every roll	mils	40.0
Thickness (min.)	ASTM D5199	Every roll	mils	36.0
Melt Index - I90/2.16 (max.)	ASTM D1238	1/Batch	g/10 min	1.0
Sheet Density (8)	ASTM D792	Every 10 rolls	g/cc	≥ 0.940
Carbon Black Content	ASTM D4218	Every 2 rolls	%	2.0 - 3.0
Carbon Black Dispersion	ASTM D5596	Every 10 rolls	Category	Cat. 1 & Cat. 2
OIT - standard (avg.)	ASTM D3895	1/Batch	min	100
Tensile Properties (min. avg.) (2)	ASTM D6693	Every 2 rolls		
Strength at Yield			ppi	88
Elongation at Yield			%	13
Strength at Break			ppi	162
Elongation at Break			%	700
Tear Resistance (min. avg.)	ASTM D1004	Every 5 rolls	lbf	28
Puncture Resistance (min. avg.)	ASTM D4833	Every 5 rolls	lbf	80
Dimensional Stability	ASTM D1204	Certified	%	± 2
Stress Crack Resistance (SP-NCTL)	ASTM D5397	1/Batch Per	hr	500
Oven Aging - % retained after 90 days	ASTM D5721	formulation		
HP OIT (min. avg.)	ASTM D5885		%	80
UV Res. - % retained after 1600 hr	ASTM D7238	Per formulation		
HP-OIT (min. avg.)	ASTM D5885		%	50
Low Temperature Brittleness	ASTM D746	Certified	°F	- 106
SUPPLY SPECIFICATIONS (Roll dimensions may vary ±1%)				

NOTES

1. Testing frequency based on standard roll dimension and one batch is approximately 180,000 lbs (or one railcar).
2. Machine Direction (MD) and Cross Machine Direction (XMD or TD) average values should be on the basis of 5 specimens each direction.
8. Correlation table is available for ASTM D792 vs ASTM D1505. Both methods give the same results.

* All values are nominal test results, except when specified as minimum or maximum.

* The information contained herein is provided for reference purposes only and is not intended as a warranty of guarantee. Final determination of suitability for use contemplated is the sole responsibility of the user. SOLMAX assumes no liability in connection with the use of this information.

Solmax is not a design professional and has not performed any design services to determine if Solmax's goods comply with any project plans or specifications, or with the application or use of Solmax's goods to any particular system, project, purpose, installation or specification.



TECHNICAL DATA SHEET

HDPE Series, 40 mils

Black, Top Side Single Textured

Tel: (450) 929-1234 Sales: (450) 929-2544 Toll free in North America: 1-800-571-3904 www.Solmax.com www.solmax.com

PROPERTY	TEST METHOD	FREQUENCY ⁽¹⁾	UNIT Imperial	
SPECIFICATIONS				
Nominal Thickness		-	mils	40
Thickness (min. avg.)	ASTM D5994	Every roll	mils	38.0
Lowest ind. for 8 out of 10 values			mils	36.0
Lowest ind. for 10 out of 10 values			mils	34.0
Asperity Height (min. avg.) (3)	ASTM D7466	Every roll	mils	16
Textured side		-		Top
Melt Index - 190/2.16 (max.)	ASTM D1238	1/Batch	g/10 min	1.0
Sheet Density (8)	ASTM D792	Every 10 rolls	g/cc	≥ 0.940
Carbon Black Content	ASTM D4218	Every 2 rolls	%	2.0 - 3.0
Carbon Black Dispersion	ASTM D5596	Every 10 rolls	Category	Cat. 1 & Cat. 2
OIT - standard (avg.)	ASTM D3895	1/Batch	min	100
Tensile Properties (min. avg.) (2)	ASTM D6693	Every 2 rolls		
Strength at Yield			ppi	88
Elongation at Yield			%	13
Strength at Break			ppi	88
Elongation at Break			%	150
Tear Resistance (min. avg.)	ASTM D1004	Every 5 rolls	lbf	30
Puncture Resistance (min. avg.)	ASTM D4833	Every 5 rolls	lbf	90
Dimensional Stability	ASTM D1204	Certified	%	± 2
Stress Crack Resistance (SP-NCTL)	ASTM D5397	1/Batch Per	hr	500
Oven Aging - % retained after 90 days	ASTM D5721	formulation		
HP OIT (min. avg.)	ASTM D5885		%	80
UV Res. - % retained after 1600 hr	ASTM D7238	Per formulation		
HP-OIT (min. avg.)	ASTM D5885		%	50
Low Temperature Brittleness	ASTM D746	Certified	°F	- 106
SUPPLY SPECIFICATIONS (Roll dimensions may vary ±1%)				

NOTES

1. Testing frequency based on standard roll dimension and one batch is approximately 180,000 lbs (or one railcar).
2. Machine Direction (MD) and Cross Machine Direction (XMD or TD) average values should be on the basis of 5 specimens each direction.
3. Lowest individual and 8 out of 10 readings as per GRI-GM13 / 17, latest version.
8. Correlation table is available for ASTM D792 vs ASTM D1505. Both methods give the same results.

(Rev. 03 / 2018-05-31)

Appendix A

USGS Groundwater Data

**ZN 34 3 FED COM (Pad 13) Temporary Pit
Section 34 of T23S, R34E, Lea County**

USGS 321357103265201 24S.34E.11.112313

DESCRIPTION:

Latitude 32°14'16.5", Longitude 103°26'49.0" NAD83

Lea County, New Mexico, Hydrologic Unit 13070007

Well depth: not determined.

Land surface altitude: 3,486 feet above NAVD88.

Well completed in "Other aquifers" (N9999OTHER) national aquifer.

Well completed in "Ogallala Formation" (121OGLL) local aquifer

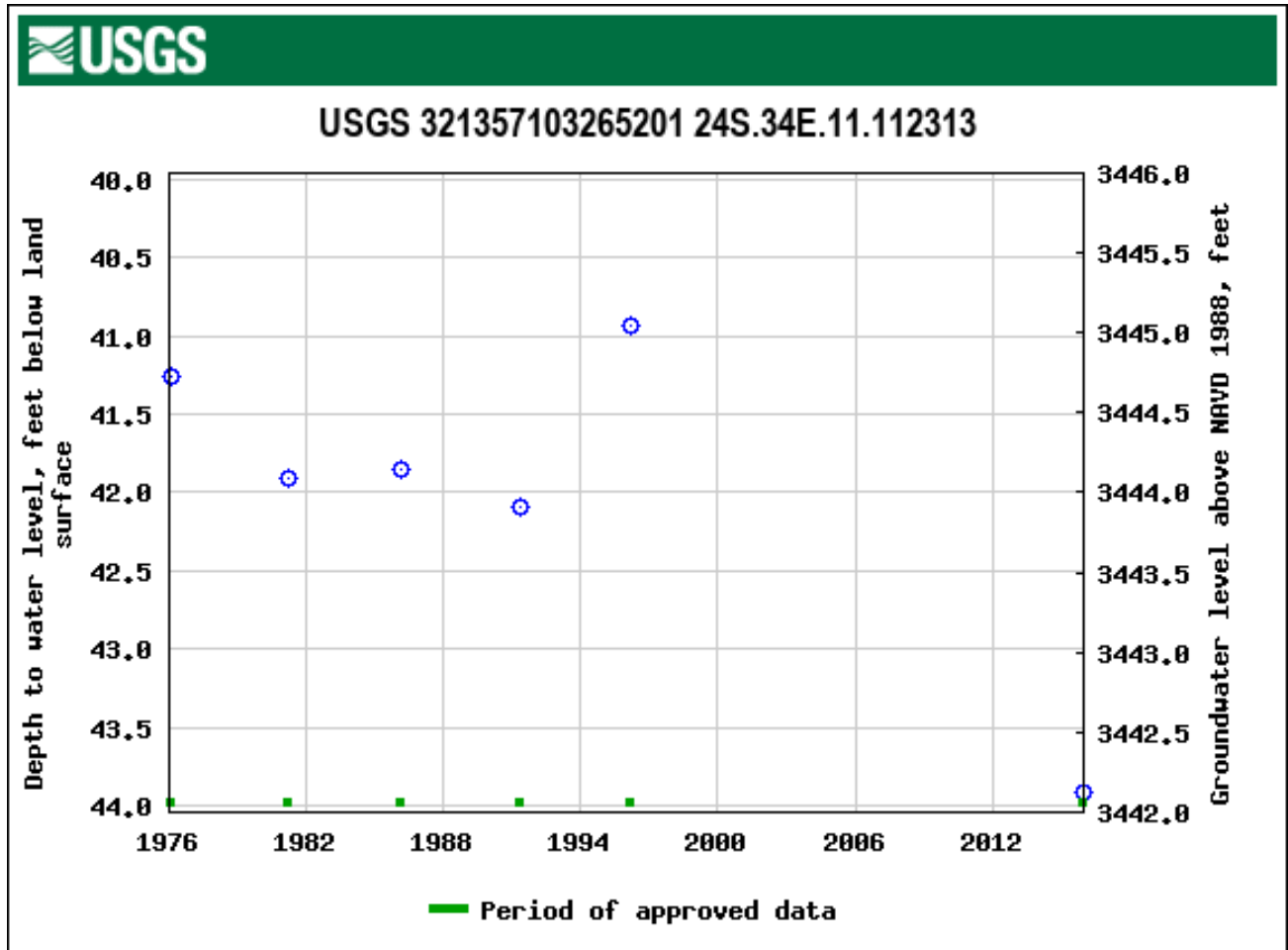

USGS 321445103282301 24S.34E.04.21431

DESCRIPTION:

Latitude 32°15'03.8", Longitude 103°28'18.7" NAD83

Lea County, New Mexico, Hydrologic Unit 13070007

Well depth: 630 feet

Land surface altitude: 3,550.00 feet above NGVD29.

Well completed in "Other aquifers" (N9999OTHER) national aquifer.

Well completed in "Santa Rosa Sandstone" (231SNRS) local aquifer

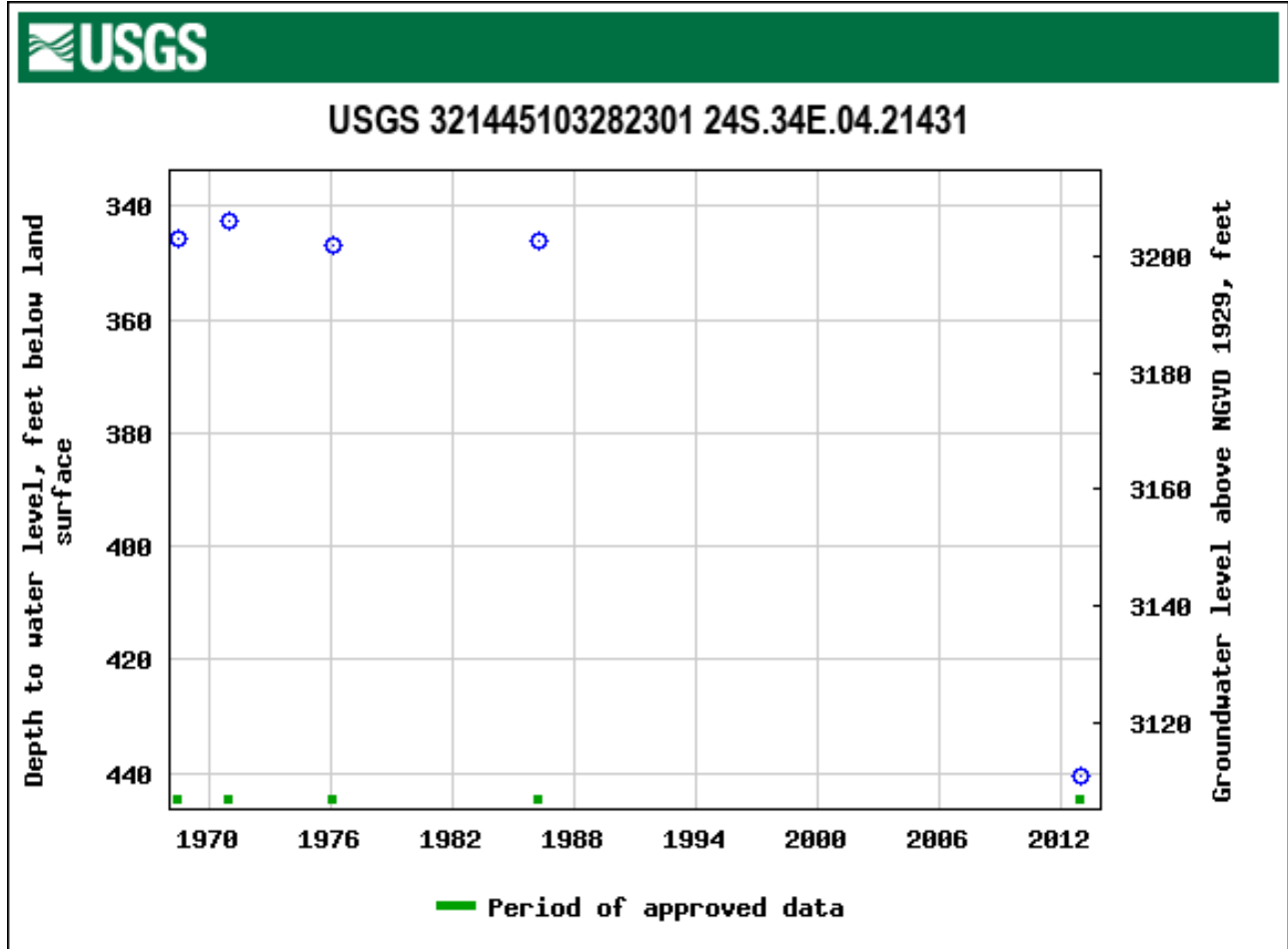

USGS 321448103285701 24S.34E.04.11321

DESCRIPTION:

Latitude 32°14'48", Longitude 103°28'57" NAD27

Lea County, New Mexico, Hydrologic Unit 13070007

Well depth: 70 feet

Land surface altitude: 3,575 feet above NAVD88.

Well completed in "Other aquifers" (N9999OTHER) national aquifer.

Well completed in "Ogallala Formation" (121OGLL) local aquifer

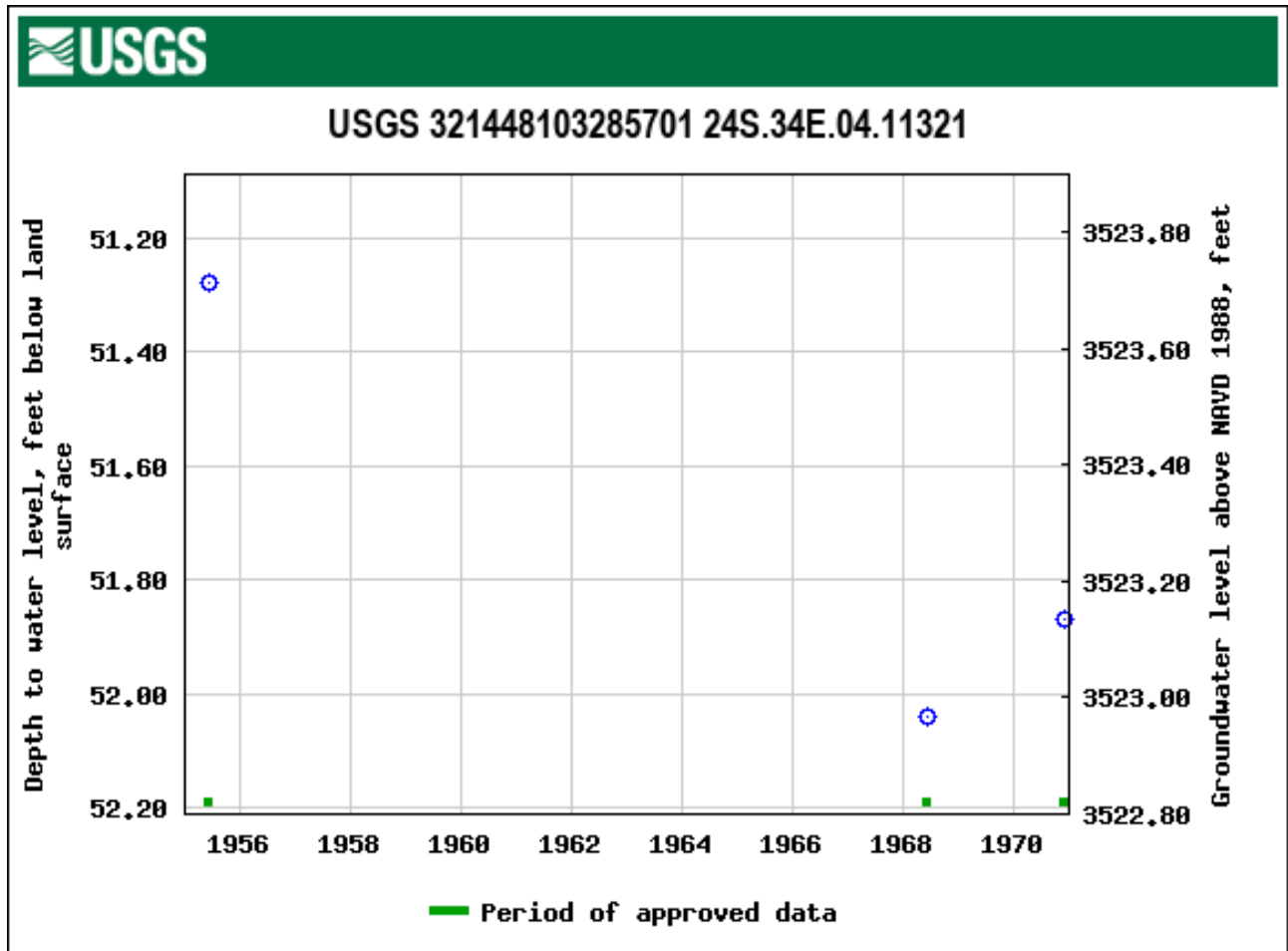

USGS 321404103290101 24S.34E.04.33333

DESCRIPTION:

Latitude 32°14'04", Longitude 103°29'01" NAD27

Lea County, New Mexico, Hydrologic Unit 13070007

Well depth: not determined.

Land surface altitude: 3,571 feet above NAVD88.

Well completed in "Other aquifers" (N9999OTHER) national aquifer.

Well completed in "Ogallala Formation" (121OGLL) local aquifer

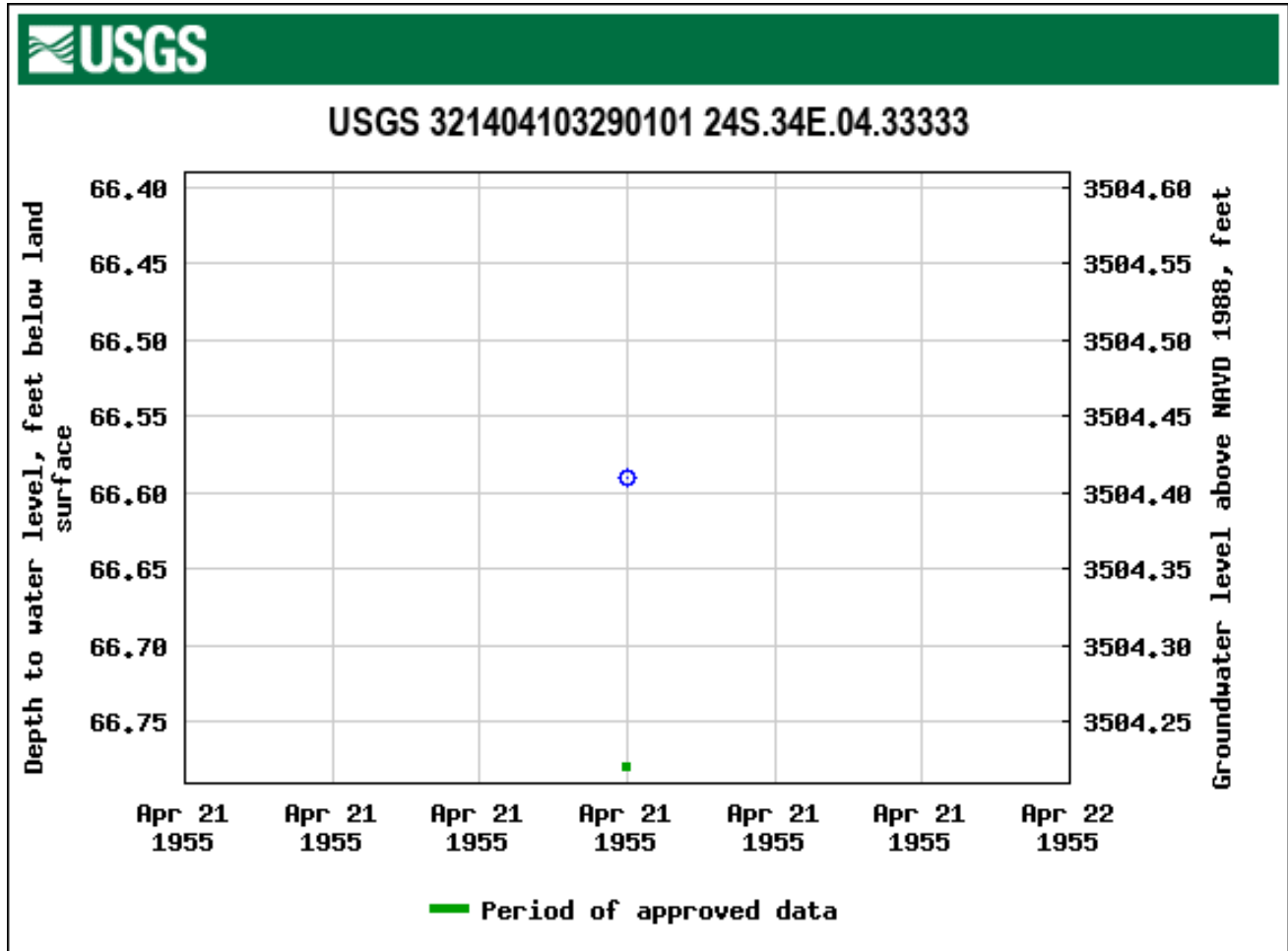

USGS 321403103300301 24S.34E.07.22222

DESCRIPTION:

Latitude 32°14'03", Longitude 103°30'03" NAD27

Lea County, New Mexico, Hydrologic Unit 13070007

Well depth: not determined.

Land surface altitude: 3,606 feet above NAVD88.

Well completed in "Other aquifers" (N9999OTHER) national aquifer.

Well completed in "Ogallala Formation" (121OGLL) local aquifer

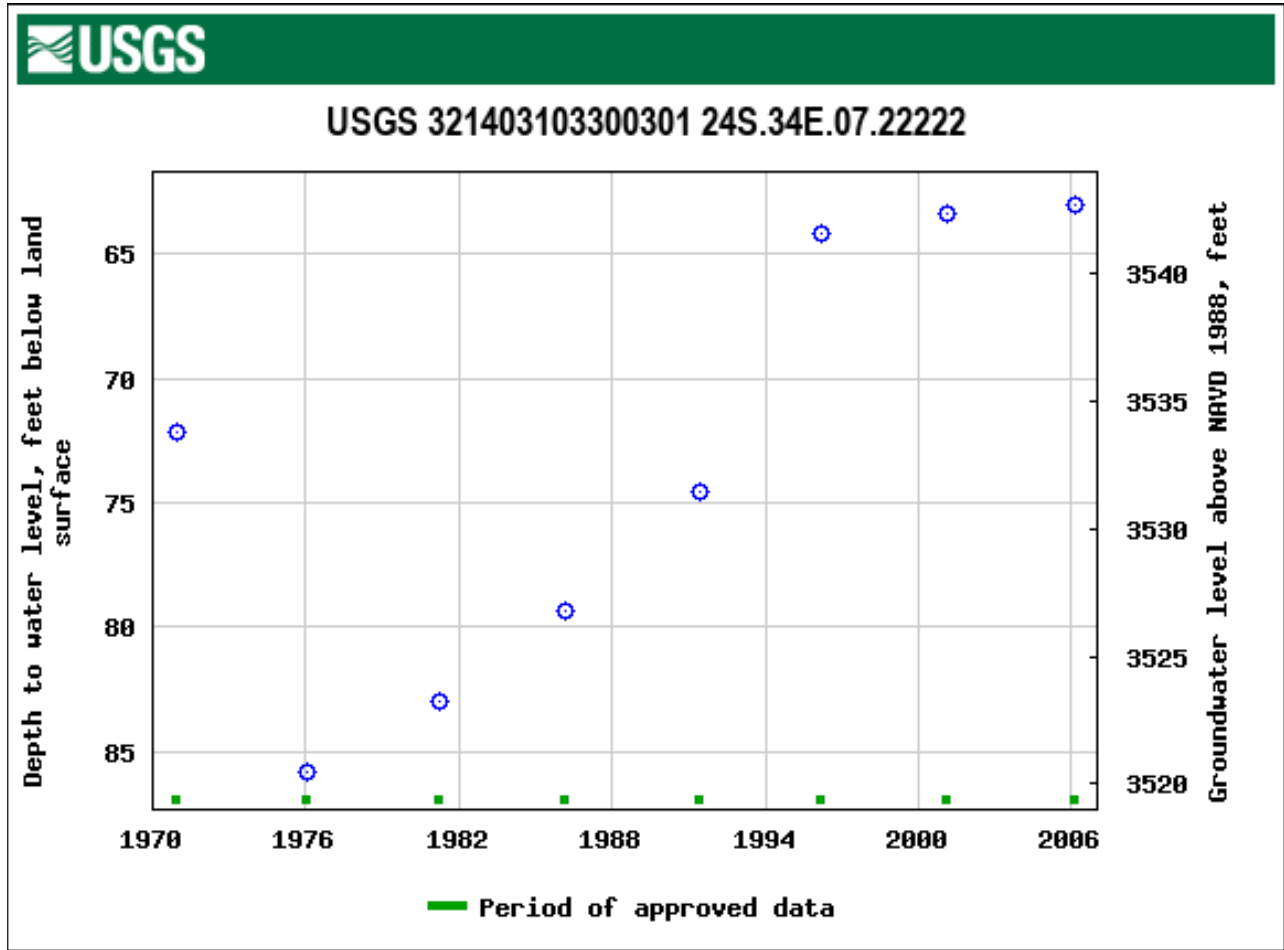

USGS 321510103302601 23S.34E.31.34

DESCRIPTION:

Latitude 32°15'15", Longitude 103°30'37" NAD27

Lea County, New Mexico, Hydrologic Unit 13070007

Well depth: not determined.

Land surface altitude: 3,618 feet above NGVD29.

Well completed in "Other aquifers" (N9999OTHER) national aquifer.

– No Hydrograph Available –

USGS 321402103274801 24S.34E.10.11221

DESCRIPTION:

Latitude 32°14'02", Longitude 103°27'48" NAD27

Lea County, New Mexico, Hydrologic Unit 13070007

Well depth: not determined.

Land surface altitude: 3,535 feet above NAVD88.

Well completed in "Other aquifers" (N9999OTHER) national aquifer.

Well completed in "Ogallala Formation" (121OGLL) local aquifer

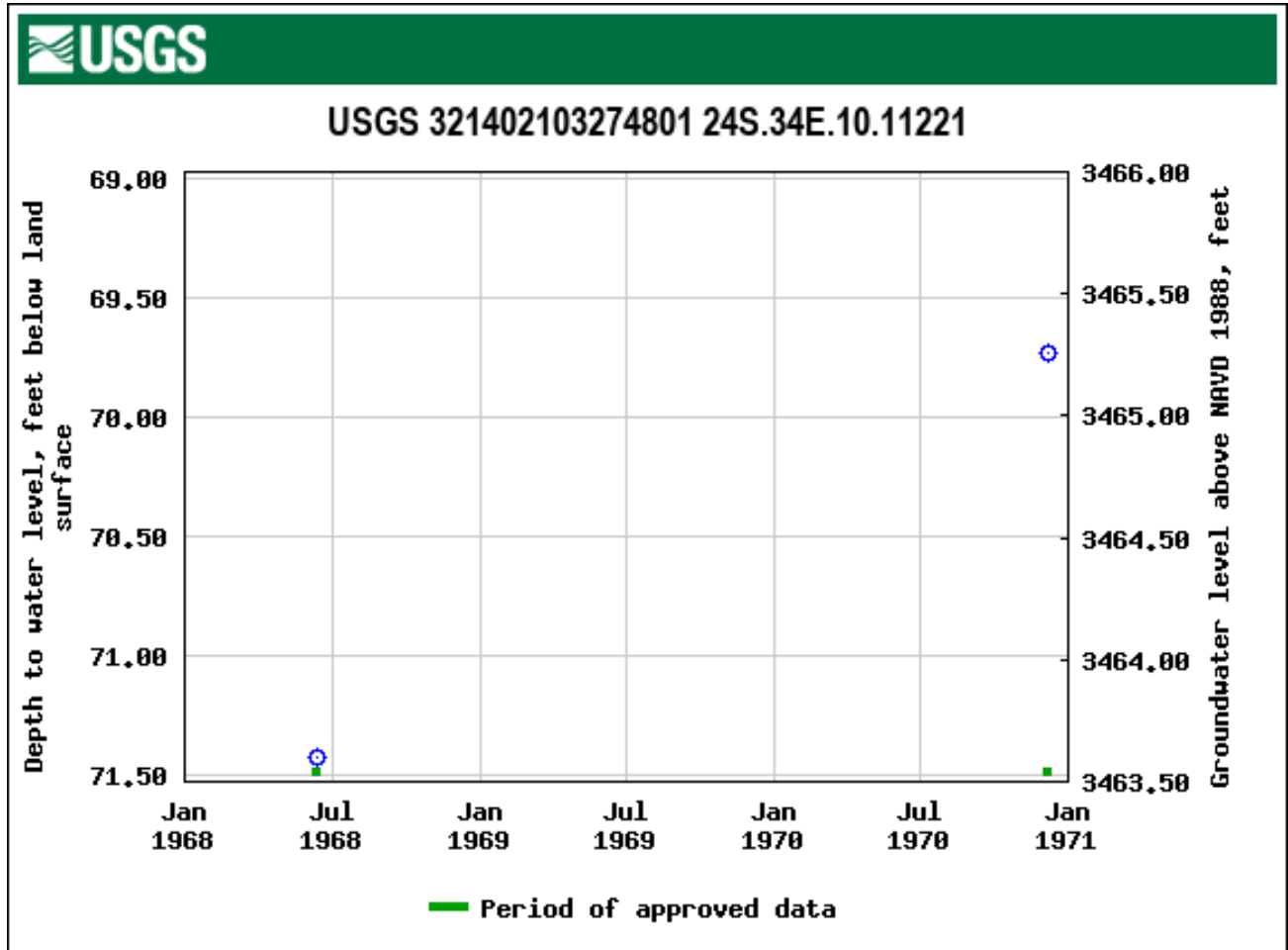

USGS 321402103275001 24S.34E.10.11212

DESCRIPTION:

Latitude 32°14'02", Longitude 103°27'50" NAD27

Lea County, New Mexico, Hydrologic Unit 13070007

Well depth: 83 feet

Land surface altitude: 3,536 feet above NAVD88.

Well completed in "Other aquifers" (N9999OTHER) national aquifer.

Well completed in "Ogallala Formation" (121OGLL) local aquifer

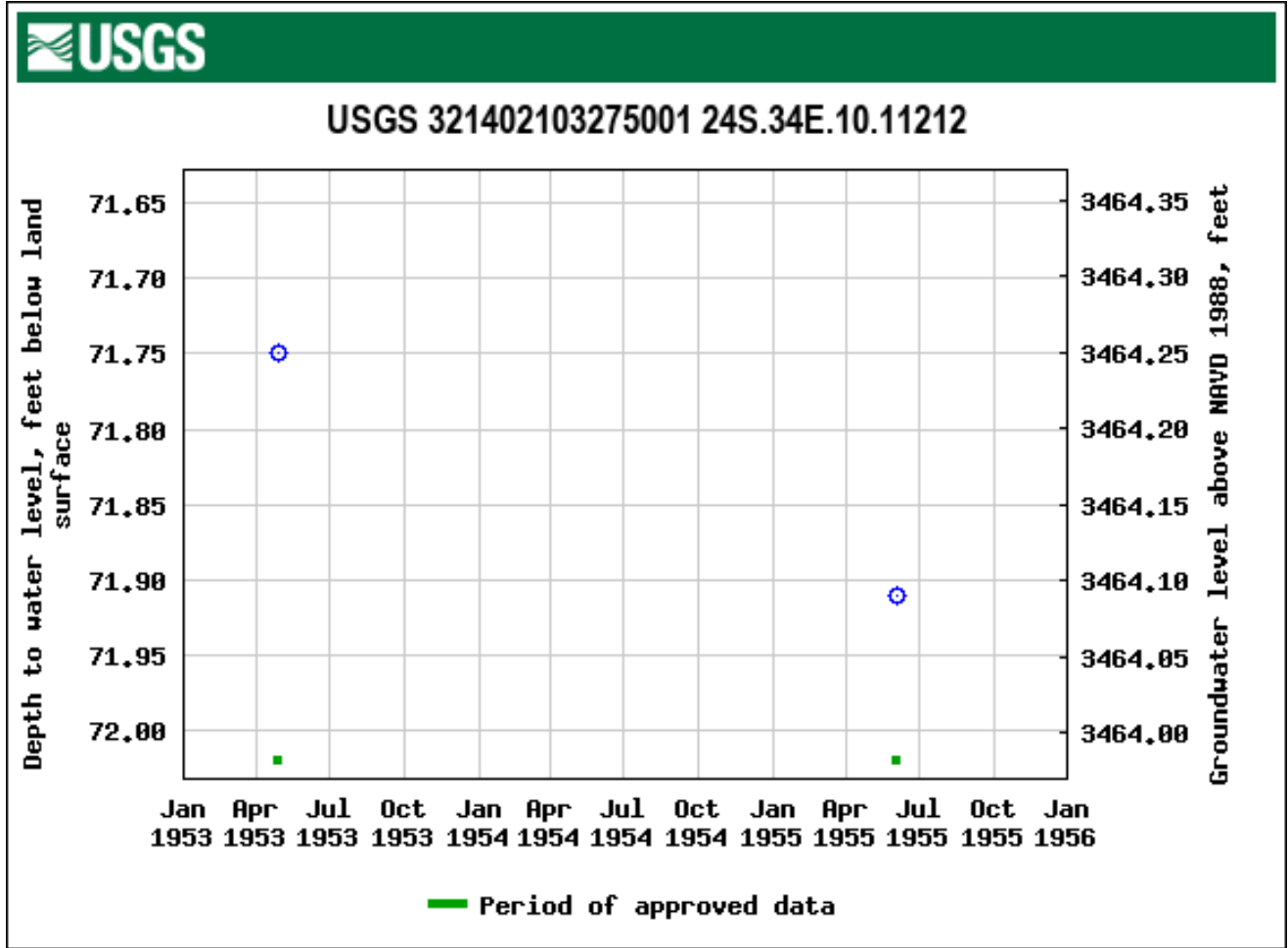

USGS 321714103270301 23S.34E.22.421434

DESCRIPTION:

Latitude 32°17'18", Longitude 103°27'08" NAD27

Lea County, New Mexico, Hydrologic Unit 13070007

Well depth: 428 feet

Land surface altitude: 3,420.00 feet above NGVD29.

Well completed in "Other aquifers" (N9999OTHER) national aquifer.

Well completed in "Santa Rosa Sandstone" (231SNRS) local aquifer

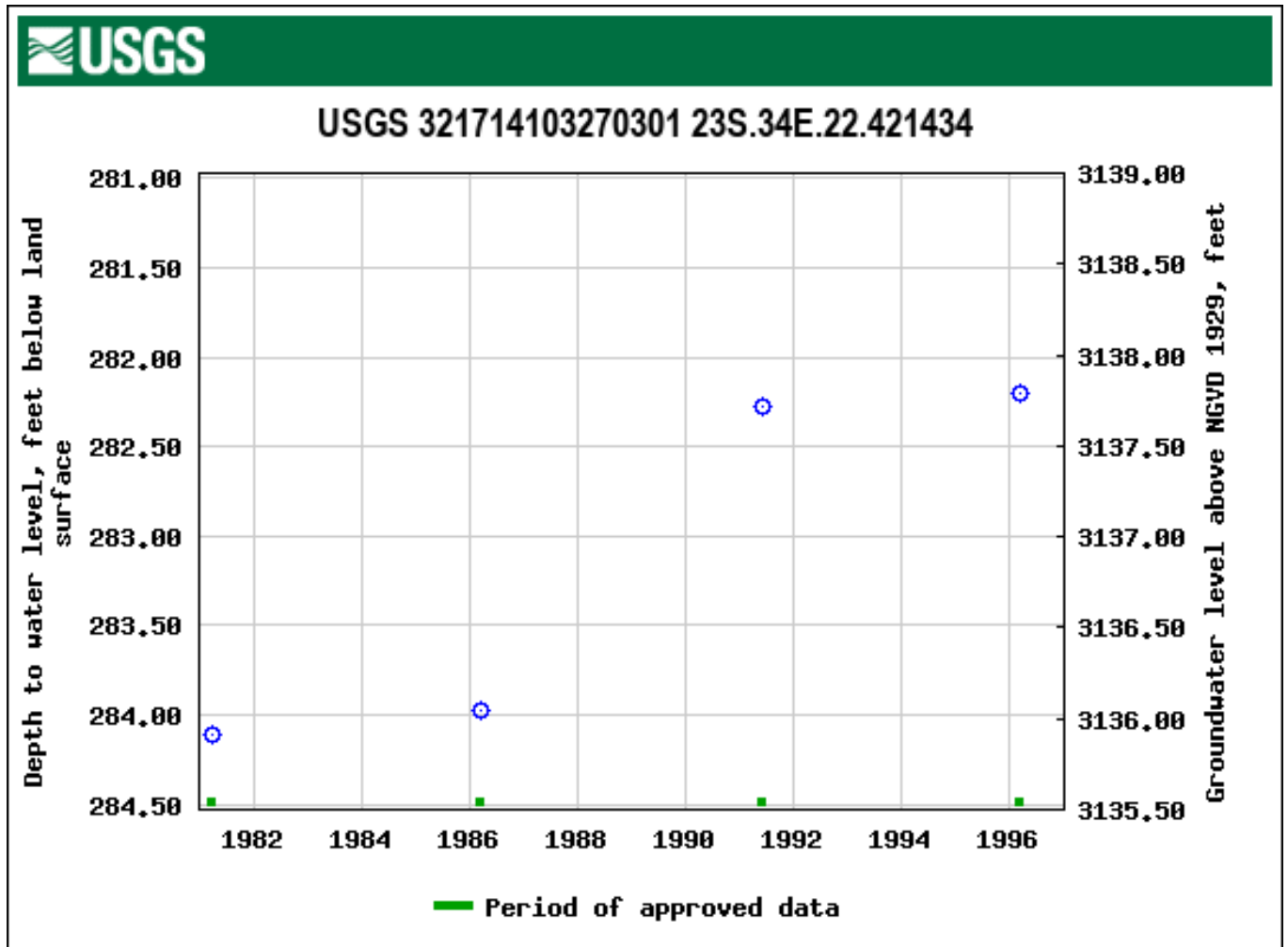

USGS 321654103261101 23S.34E.23.42332

DESCRIPTION:

Latitude 32°16'54", Longitude 103°26'11" NAD27

Lea County, New Mexico, Hydrologic Unit 13070007

Well depth: 500 feet

Land surface altitude: 3,389 feet above NAVD88.

Well completed in "Other aquifers" (N9999OTHER) national aquifer.

Well completed in "Santa Rosa Sandstone" (231SNRS) local aquifer

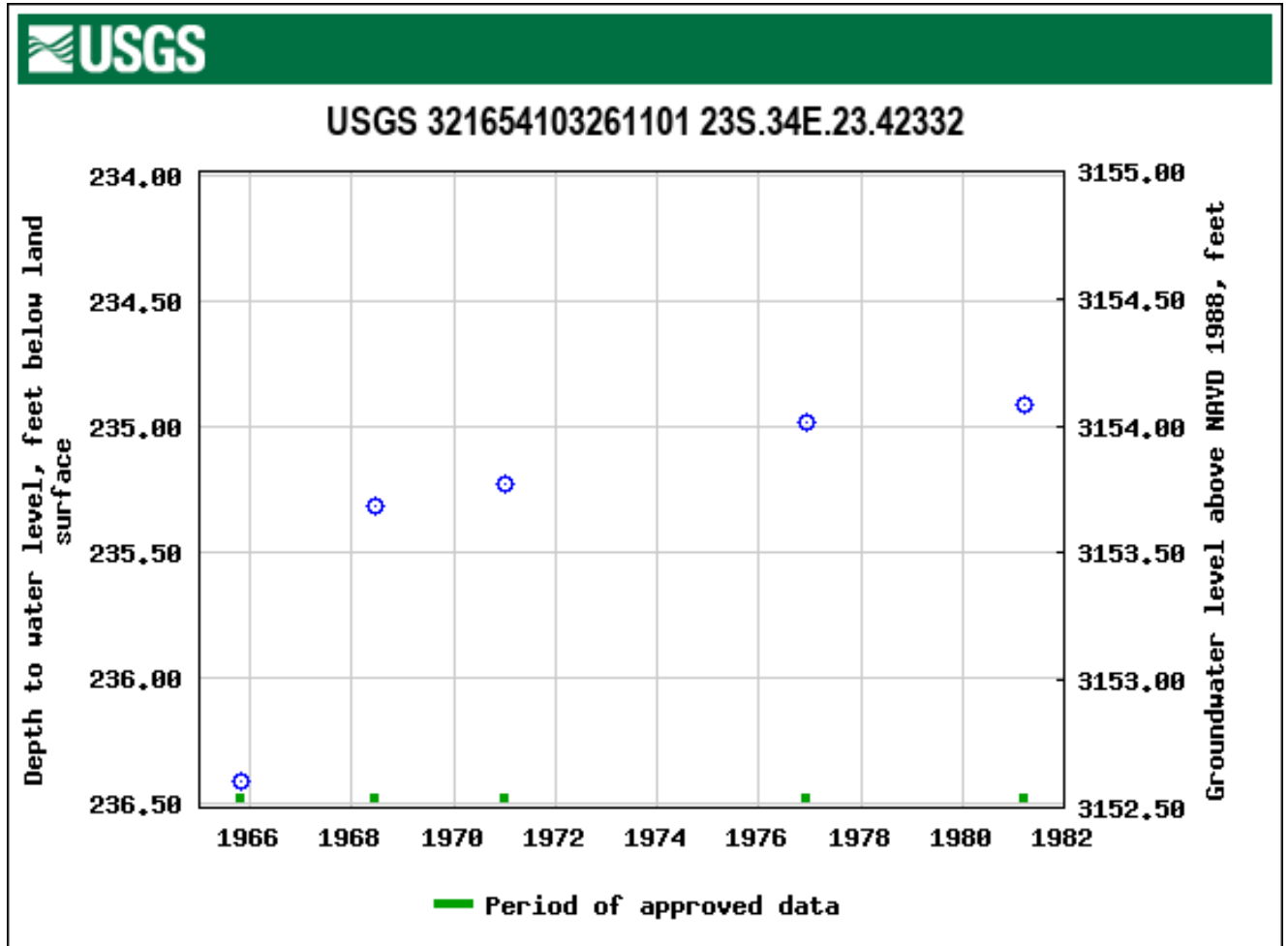

USGS 321652103261101 23S.34E.23.42334

DESCRIPTION:

Latitude 32°16'52", Longitude 103°26'11" NAD27

Lea County, New Mexico, Hydrologic Unit 13070007

Well depth: not determined.

Land surface altitude: 3,390 feet above NAVD88.

Well completed in "Other aquifers" (N9999OTHER) national aquifer.

Well completed in "Santa Rosa Sandstone" (231SNRS) local aquifer

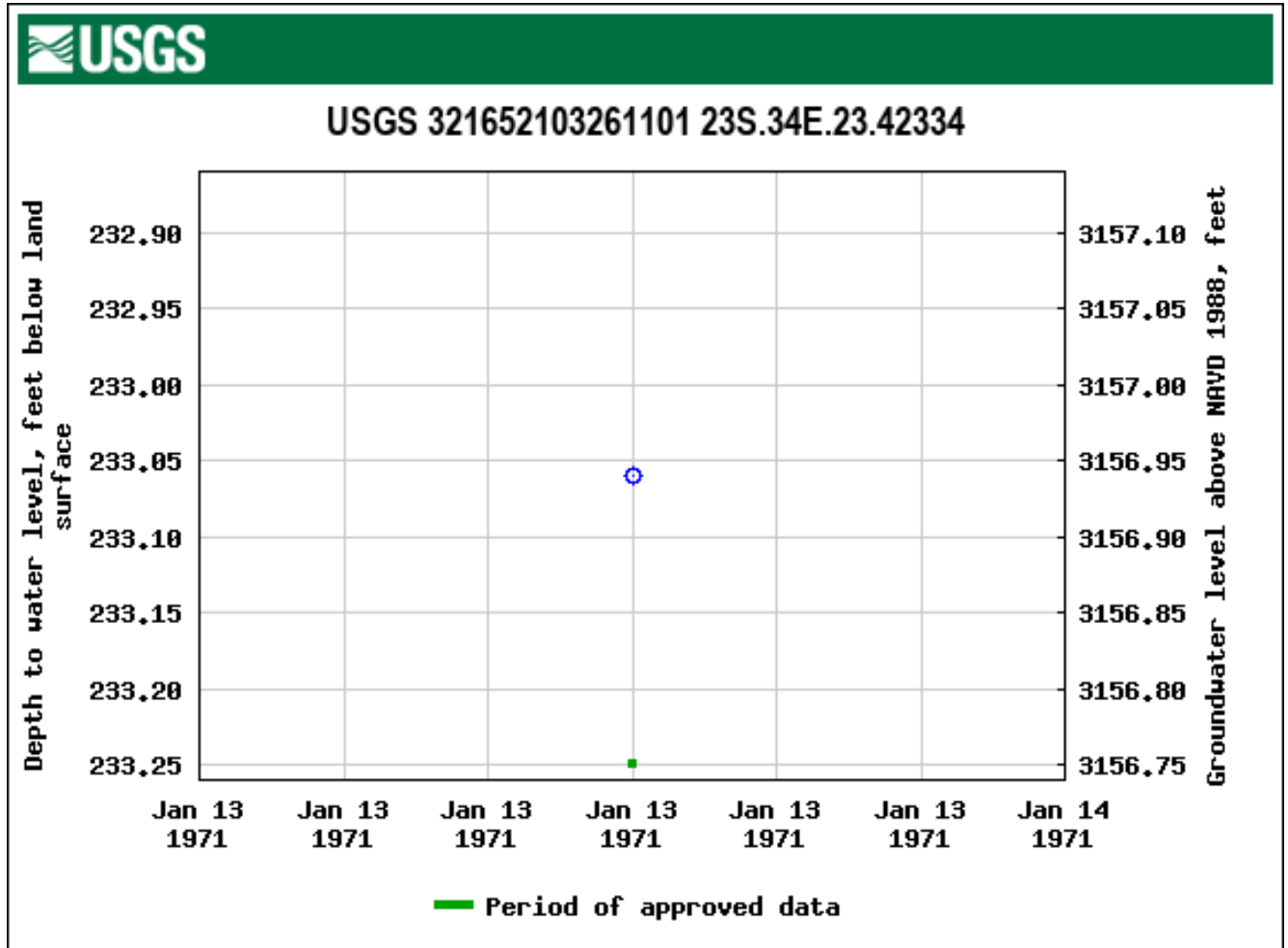

Appendix B

NMOSE Water Data

**ZN 34 3 FED COM (Pad 13) Temporary Pit
Section 34 of T23S, R34E, Lea County**



New Mexico Office of the State Engineer

Water Column/Average Depth to Water

(A CLW##### in the POD suffix indicates the POD has been replaced & no longer serves a water right file.)

(R=POD has been replaced, O=orphaned, C=the file is closed)

(quarters are smallest to largest)

(meters)

(In feet)

POD Number	Code	Sub basin	County	Q64	Q16	Q4	Sec	Tws	Range	X	Y	Map	Distance	Well Depth	Depth Water	Water Column
CP 01977 POD1		CP	LE	SW	SW	SW	23	23S	34E	646093.4	3572949.8	●	1869	55		
CP 00580		CP	LE	SW	SE	SW	23	23S	34E	646524.0	3572948.0 *	●	1955	220		
CP 01258 POD2		CP	LE	NW	SE	SW	22	23S	34E	644941.2	3572883.9	●	2043	65		
CP 01258 POD3		CP	LE	NW	SE	SW	22	23S	34E	644938.1	3573097.3	●	2234	25		
CP 01258 POD1		CP	LE	NW	SE	SW	22	23S	34E	645014.8	3573221.6	●	2316	25		
CP 00618		CP	LE	NW	NE	SE	22	23S	34E	645713.0	3573539.0 *	●	2458	428	295	133
C 02386		CUB	LE	SE	NW	NE	04	24S	34E	643962.0	3569290.0 *	●	2657	575	475	100
C 02397		CUB	LE	SE	NW	NE	04	24S	34E	643962.0	3569290.0 *	●	2657	575	475	100
CP 00606		CP	LE		SE	NW	23	23S	34E	646613.0	3573854.0 *	●	2851	650	265	385
CP 00637		CP	LE	SW	SW	SE	15	23S	34E	645293.0	3574541.0 *	●	3508	430	430	0
C 02387		CUB	LE			NW	11	24S	34E	646513.0	3567613.0 *	●	3526	62	40	22
CP 01120 POD1		CP	LE	NE	SW	SW	14	23S	34E	646366.3	3574753.5	●	3691	397	318	79
CP 01785 POD1		CP	LE	SE	NW	SW	14	23S	34E	646203.1	3575003.7	●	3925	488	245	243
C 03932 POD3		CUB	LE	SE	SW	NE	05	24S	34E	642442.0	3568787.7	●	4168	100		
C 03620 POD1		CUB	LE	NW	SE	SW	32	23S	34E	641790.2	3569941.6	●	4284	480	130	350
C 04282 POD1		C	LE	NW	NE	NW	05	24S	34E	641662.4	3569541.6	●	4528	574	390	184
C 04667 POD1		CUB	LE	SW	SE	SW	20	23S	34E	641770.5	3572915.3	●	4532			
CP 01984 POD1		CP	LE	SE	NW	NE	30	23S	35E	650426.8	3572704.1	●	4789			
CP 01830 POD1		CP	LE	SW	SW	SW	18	23S	35E	649288.7	3574568.4	●	4844	460	270	190
CP 01836 POD1		CP	LE	SE	SW	SE	11	23S	34E	647123.2	3576135.2	●	5188	940	285	655
CP 00614 POD2		CP	LE	SE	SW	SW	29	23S	35E	651102.0	3571401.1	●	5193	440	320	120
CP 01730 POD1		CP	LE	NE	NE	NW	16	23S	34E	643549.2	3575824.7	●	5295	594	200	394
CP 01760 POD1		CP	LE	SW	NW	NE	16	23S	34E	643627.4	3575897.6	●	5326	767	290	477
C 04814 POD1		CUB	LE	SW	SE	NE	06	24S	34E	641053.2	3568837.6	●	5360	55		
CP 01837 POD1		CP	LE	SE	NW	SW	11	23S	34E	646340.9	3576634.2	●	5561	960	300	660
CP 01839 POD1		CP	LE	SW	NW	SW	12	23S	34E	647594.5	3576634.9	●	5793	860	286	574
C 03932 POD13		CUB	LE	SE	NE	SW	15	24S	34E	645314.2	3565203.5	●	5916	90		
CP 01838 POD1		CP	LE	SW	SW	SW	07	23S	35E	649294.1	3576148.6	●	6082	740		
C 03932 POD8		CUB	LE	SE	NE	SE	07	24S	34E	641120.0	3566769.9	●	6455	72		
CP 01840 POD1		CP	LE	NW	NW	NW	11	23S	34E	646007.0	3577597.5	●	6509	969	285	684
C 04014 POD1		CUB	LE	NW	NW	SW	06	24S	34E	639811.3	3568638.9	●	6579	91	81	10
CP 00556 POD1		CP	LE	SE	SE	SW	08	23S	34E	641762.5	3576206.3	●	6592	497	255	242
C 04014 POD2		CUB	LE	SE	SE	NE	01	24S	33E	639655.6	3568917.1	●	6628	95	81	14
CP 02065 POD1		CP	LE	NE	NW	NW	17	23S	34E	641388.8	3575938.6	●	6635	105		
C 04014 POD3		CUB	LE	NE	SE	NE	01	24S	33E	639497.3	3569007.3	●	6749	95	87	8
CP 01841 POD1		CP	LE	SW	SW	SW	03	23S	34E	644389.5	3577684.8	●	6770	650	295	355
CP 01099 POD3		CP	LE	NW	NW	NW	28	23S	35E	652478.3	3572932.0	●	6814	930	725	205
C 04014 POD5		CUB	LE	NW	SE	NE	01	24S	33E	639284.2	3569086.3	●	6929	95	85	10
C 03943 POD1		CUB	LE	NE	SE	NE	21	24S	34E	644522.6	3564266.6	●	6963	610	431	179
C 04014 POD4		CUB	LE	SW	SE	NE	01	24S	33E	639295.2	3568859.7	●	6988	96	86	10

(A CLW##### in the POD suffix indicates the POD has been replaced & no longer serves a water right file.) (R=POD has been replaced, O=orphaned, C=the file is closed)

(quarters are smallest to largest)

POD Number	Code	Sub basin	County	Q64	Q16	Q4	Sec	Tws	Range	X	Y	Map	(meters)		(In feet)	
													Distance	Well Depth	Depth Water	Water Column
CP 01099 POD2		CP	LE	SW	SW	SW	21	23S	35E	652968.3	3572750.9	●	7243	750	120	630
CP 01100 POD3		CP	LE	SW	NE	NW	28	23S	35E	652987.2	3572726.3	●	7256	950	730	220
CP 01100 POD2		CP	LE		NE	NW	28	23S	35E	652995.1	3572726.4	●	7263	750	125	625
CP 01622 POD1		CP	LE	NW	SW	SW	04	23S	34E	642829.6	3577872.3	●	7453	575	285	290
CP 01886 POD1		CP	LE	SE	NW	SE	07	23S	34E	640645.6	3576545.2	●	7587			
CP 01502 POD2		CP	LE	SE	SW	SW	05	23S	34E	642073.9	3577676.9	●	7627	680	300	380
C 04737 POD1		CUB	LE	NW	SW	SW	24	24S	34E	647828.5	3563471.0	●	7853	250		
C 04838 POD1		CUB	LE	SE	SE	SE	12	24S	33E	639536.1	3566499.4	●	7860	105		
C 04458 POD1		CUB	LE	SE	NW	NW	20	24S	34E	641549.2	3564532.9	●	7878		0	
C 02282		CUB	LE	SW	NW	NW	25	23S	33E	638098.0	3572436.0 *	●	7935	325	225	100
CP 01075 POD1		CP	LE	NW	NW	NW	08	23S	34E	641295.1	3577544.6	●	7940	430	20	410
CP 00872 POD1		CP	LE	NW	NW	NW	08	23S	34E	641225.0	3577504.0 *	●	7948	494	305	189
CP 01502 POD1		CP	LE	SE	SW	SW	05	23S	34E	641316.1	3577635.4	●	8002	648	200	448
C 02284		CUB	LE	SE	NE	SE	26	23S	33E	637907.0	3571626.0 *	●	8029	325	225	100

Average Depth to Water: **262 feet**

Minimum Depth: **0 feet**

Maximum Depth: **730 feet**

Record Count: 54

Basin/County Search:

County: LE

UTM Filters (in meters):

Easting: 645918.16

Northing: 3571088.83

Radius: 008045

* UTM location was derived from PLSS - see Help

The data is furnished by the NMOSE/ISC and is accepted by the recipient with the expressed understanding that the OSE/ISC make no warranties, expressed or implied, concerning the accuracy, completeness, reliability, usability, or suitability for any particular purpose of the data.

Appendix C

Hydrogeologic Data

**ZN 34 3 FED COM (Pad 13) Temporary Pit
Section 34 of T23S, R34E, Lea County**

Appendix C – Hydrogeologic Data

ZN 34 3 FED COM (Pad 13) Temporary Pit

Topography and Surface Hydrology

The location of the proposed temporary pit is in Lea County, New Mexico approximately 2.5 miles east of Antelope Ridge in the Pecos Valley section of the Great Plains physiographic province. The pit lies at an elevation of 3,456 feet above sea level with relatively flat to gentle sloping terrain and no well-established drainages (**Figure 6**). Antelope Draw occurs approximately 0.5 miles southeast of the location and drains to the southeast. No other well-established drainages occur in the vicinity of the proposed temporary pit.

Surface water within the proposed pit area is affected naturally by the shallow geology, precipitation, and some water erosion. The area is located in the semi-arid southwest near the northern edge of the Chihuahuan Desert. The climate is characterized by low annual precipitation, low humidity, and high average annual temperature and ranges from dry subhumid to arid. Precipitation is quite variable both regionally and seasonally and averages about 12 inches or less annually with the greatest rainfall occurring as monsoonal storms during the summer months. The area is situated at the southwest edge of the Great Plains dust-bowl area and is sometimes subjected to severe windstorms (Nicholson and Clebsch 1961).

Southwestern Lea County, including the proposed pit area, lies within the Lower Pecos River Basin. The major stream in this Basin is the Pecos River, which is located approximately 26 miles to the west in southeastern Eddy County. Surface water in the Lower Pecos River Basin comes from three main sources: inflow from the Upper Pecos River Basin, flood inflow from storm events, and groundwater base inflow.

Anthropogenic activities that currently affect surface water resources in the proposed pit area include livestock grazing management and oil and gas development. Surface water flow direction is likely to the northeast following the surface topography. To the southeast of the proposed pit location, surface water likely flows into Antelope Draw and along the draw in a southeasterly direction. No other draws or other well-established drainage features occur in the proposed pit area.

Soils

The soil complexes mapped within the survey area are the Berino-Cacique loamy fine sands association (BE) and the Tonuco loamy fine sand (TF) and are described further in the following table. A map depicting the soils mapped within the area is provided in **Figure 10** and summarized in **Table 1**.

Table 1 Soils Within the Survey Area

Soil Abbreviation and Name	Slope	Soil Type
BE – Berino-Cacique loamy fine sands association	0 to 3 percent slope	Deep
TF – Tonuco loamy fine sand	0 to 3 percent slope	Deep

Loamy Sand Soil Type Description

All the soils within the survey area are classified as loamy sand soils. These loamy sand soils consist of the Berino and Cacique. These soils are typically moderately deep or very deep soils that consist of loamy sand underlain by fine sands. Slopes range from 0 to 3 percent within these loamy sand soils. If these soils are unprotected by plant cover, they are easily wind blown into low hummocks. These soils have rapid permeability and are well drained. These soils support grassland vegetative communities dominated by species such as sand bluestem, yellow Indiangrass, black grama, dropseed species, and little bluestem. Dominant shrub species observed within these soils were creosote bush (*Larrea tridentate*), mesquite (*Prosopis glandulosa*), rubber rabbitbrush (*Ericameria nauseosa*), and yucca sp. (*Yucca sp.*). The annual grasses and forbs population will fluctuate with the variation of amount of rainfall annually and with the seasons. Without brush and graze control the vegetative communities within these soils will become shrub dominate, and there will be a loss of grass cover and increased surface soil erosion (USDA 2016).

Geology

The area in the vicinity of the proposed pit location is underlain by recent eolian deposits consisting of drift sand a few feet in thickness and local occurrences of sand dunes (**Figure 9**). The eolian deposits are underlain by Pleistocene to recent alluvial deposits consisting of unconsolidated to partially consolidated sand, silt, gravel, clay and caliche. A thin layer of Tertiary Ogallala Formation may underlie the alluvium. Alluvium thickness in this area appears to be approximately 100 feet or less. Triassic Dockum strata underlie the alluvium deposits and its thickness appears to be approximately 500 feet or more. The Dockum Group has been divided into three formations: lower red shale, siltstone, and very fine-grained sandstone called the Tecovas Formation (or Pierce Canyon redbeds); middle reddish-brown and gray sandstone called the Santa Rosa sandstone; and upper brick-red to maroon and purple shale with thin beds of fine red or gray sandstone and siltstone called the Chinle Formation.

- The Tecovas or Pierce Canyon redbeds (considered Permian by some geologists and sometimes correlated with the Dewey Lake redbeds) overlie the Rustler Formation. The Tecovas' thickness is approximately 350 feet and it consists of red sandy shale and fine-grained sandstones with greenish-gray inclusions.
- The Santa Rosa sandstone consists of reddish-brown and gray, medium- to coarse-grained, micaceous, well-cemented sandstone and conglomerate. The sandstone is

typically cross-bedded and is interbedded with red shale and siltstone. The thickness of the Santa Rosa sandstone generally ranges from approximately 200 to 300 feet over most of the area where it occurs.

- The Chinle Formation consists of a series of red shales and thin interbedded sandstones and appears to be about 200 feet thick in this area but can be as much as several hundred feet thick in other parts of southern Lea County (located to the east).

Dewey Lake rebeds (sometimes correlated with the Tecovas Formation) underlie the Triassic Dockum and overlie the Rustler Formation. Dewey Lake is a series of red beds consisting of micaceous red siltstone, shale, and sandstone with gypsum cementation

The Rustler Formation consists largely of anhydrite, gypsum, interbedded sandy clay and shale, and dolomitic limestone near the upper part of the formation. The Rustler overlies the Salado Formation and is approximately 400 feet thick in this area (Nicholson and Clebsch 1961). The Rustler typically consists of a lower clastic unit composed mainly of red and gray shale and some interbedded anhydrite and an upper anhydrite unit containing dolomitic limestone beds of varying thicknesses.

Geologic units in the general area which potentially contain usable groundwater are the Alluvium/Ogallala, the Dockum Group, and possibly the Rustler Formation.

Groundwater

In the vicinity of the proposed pit, the Rustler Formation, Dockum Group and the Alluvium have the potential to provide small quantities of water to water supply wells. However, no water wells were found at in the immediate vicinity of the proposed site (**Figure 7**) with the closest well located approximately 1.25 miles to the northeast and southwest. It is approximately 1.25 miles to the southwest to the closest well with reported depth to water data. Several water wells have been identified within 1.25 to 5 miles of the site) which are used primarily to support domestic, livestock and / or oil and gas exploration and development water needs. The depths of the wells indicate that some are completed in the Alluvium, some in the Triassic Dockum and some completed in the lower part of the Triassic Dockum or possibly the Rustler Formation.

Depth to Water: An analysis of publicly available data from the NMOSE and USGS indicate that the depth to groundwater beneath the proposed location is 40 feet or more based on a NMOSE-gauged well which is located approximately 2.3 miles south of the proposed site. Other NMOSE wells located near the proposed site (within 1.5 to 2.5 miles) have reported depths to water in excess of 130 feet. The depths to water within a 5-mile radius of the proposed site range from 20 feet (approximately 4.8 miles northwest of the proposed site) to 730 feet in a well located approximately 4.8 miles northeast of the proposed site. There are no USGS-gauged wells in the 5-mile radius around the proposed site, but several are located in the immediately surrounding area. Water levels in these wells range from 75 feet to 474 feet.

Groundwater within 5 miles of the proposed location appears to be present in the Pecos River Basin Alluvial aquifer contained within Quaternary deposits present at surface and underlain by the Triassic Dockum Formation. In this area, the Alluvium appears to be approximately 100 feet in thickness. The proposed location, however, is located above the mapped extent of the Pecos River Basin Alluvial aquifer but the alluvial aquifer in this area is relatively thin and has low productivity in terms of well yields. The Triassic Dockum formations, which underlie the Alluvium, are also sources of potable water. There are many water wells within 5 miles of the location based on the NMOSE data but no water wells within 1 mile of the location. Reported well yields in the NMOSE database for the water wells in the general area range from very low (less than 5 gallons per minute (gpm) for the shallow wells (325 feet or less in depth) and 30 gpm to 320 gpm for the deeper wells completed in the Triassic Dockum or possible the Rustler Formation. A 475-foot deep well located approximately 4.5 miles east-northeast of the proposed site appears to be completed in the Rustler Formation.

Recharge:

Recharge is by direct precipitation and infiltration from intermittent streamflow and subsurface groundwater flow from upgradient areas. The region is characterized by an annual precipitation of 10 to 20 inches and high average annual evaporation rates. Most recharge is episodic and associated with periods of heavy rainfall. Recharge is most likely to occur during long-duration rainfall events or periods of frequent, smaller rainfall events. Otherwise the water is has a high likelihood of being lost to evapotranspiration. The average annual recharge rate for the Pecos River Basin aquifer in the general area (including Lea County) is between 0 and 0.5 inches/year (Hutchison et al., 2011).

References

- Hutchison, W. R., I. C. Jones and R. Anaya. 2011. Update of the groundwater availability model for the Edwards-Trinity (plateau) and Pecos Valley aquifers of Texas.
- New Mexico Office of the State Engineer (NMOSE). 2010. New Mexico Water Rights Reporting System Water Column/Average Depth to Water Report. [Web page]. Located at <http://nmwrrs.ose.state.nm.us/nmwrrs/waterColumn.html>. Accessed: October 2025.
- Nicholson, Alexander, Jr. and Clebsch, Alfred, Jr. 1961. Ground-Water Report 6 – Geology and Ground-Water Conditions in Southern Lea County, New Mexico. United States Geological Survey in cooperation with the New Mexico Institute of Mining and Technology, State Bureau of Mines and Mineral Resources Division and the New Mexico State Engineer.
- U.S. Department of Agriculture (USDA). 2013. Natural Resources Conservation Service. Soil Surveys by State available at www.nrcs.usda.gov.
- USDA. 2016. Sandy Ecological Site Characteristics. [Web page]. Located at <https://esis.sc.egov.usda.gov/ESDReport/fsReport.aspx?approved=yes&repType=regular&id=R042XA051NM>. Accessed: September 2025.

Appendix D

Design Plan

**ZN 34 3 FED COM (Pad 13) Temporary Pit
Section 34 of T23S, R34E, Lea County**

Appendix D – Design Plan

ZN 34 3 FED COM (Pad 13) Temporary Pit

The Operator will design and construct the temporary pit to contain liquids and solids; prevent contamination of fresh water; and protect public health and the environment. The Design and Construction will follow the requirements listed below:

- The topsoil will be stripped and stockpiled prior to construction for use as the final cover during closure.
- A sign, consistent the requirements of 19.15.16.8 NMAC, will be utilized and made viewable at the location of the pit.
- Fencing will be in place around the perimeter of the pits and the Operator will ensure it remains in good repair until closure.
- Netting will not be installed on the temporary pit; however, the operator will inspect for and report any discovery of dead migratory birds or other wildlife while the pit contains fluid and is in use.
- The design of the pit, including the berms, geomembrane material, and construction notes below, is intended to ensure the confinement of liquids to prevent releases.
- The subgrade and interior slopes will be screened for deleterious materials and rocks and will be suitable for the liner installation. An underlying geotextile may be used to provide additional protection from puncture or stress cracking.
- The slopes of the pit will be constructed at a two horizontal to one vertical foot ratio.
- A 40-mil HDPE liner resistant to petroleum hydrocarbons, salts and acidic and alkaline solutions, and ultraviolet light will be installed in the pit. Liner compatibility will comply with EPA SW-846 Method 9090A. Technical data sheets for the liner material can be found in *Variance Request 2 of 2 – Proposed Use of High-Density Polyethylene (HDPE) Liner for Temporary Pit in lieu of Linear Low-Density Polyethylene (LLDPE) Liner*.
- Liner seams will be minimized as is practical during construction and will only be oriented up and down a slope. When field welding the liner seams, the liner will overlap a minimum of 4 inches and a maximum of 6 inches. Welds will be minimized in corners and irregularly shaped area. Welds will only be performed by qualified personnel.

- Construction will avoid excessive stress-strain on the liner by screening the subgrade for deleterious materials and rock and using geotextile where needed, utilizing experienced personnel for the installation of the liner, taking care when unrolling liner material and limiting the use of any machinery that could damage the liner.
- The edges of the liner will be anchored in the bottom of a compacted earth field trench that is 18 inches deep.
- Impingement of liquids onto the liner will be prevented by use of a loose hose discharge method. The design ensures fluid enters a malleable section of hose laying on the pit berm prior to entering the pit preventing direct impingement.
- The design includes a 4-foot berm and bar ditch around the entirety of the pit to prevent run on of surface water. The berm will be maintained from construction to closure.
- The volume of the temporary pit is 6.6 acre-ft including freeboard.
- No venting or flaring of gas will take place during the construction, use, and closure of the pit and, as such, the entirety of the pit will be lined.

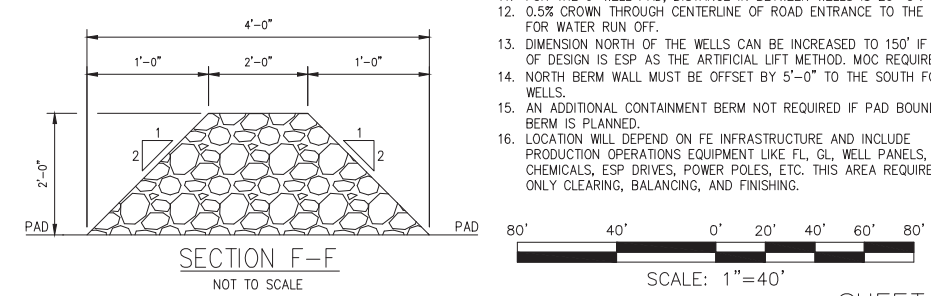
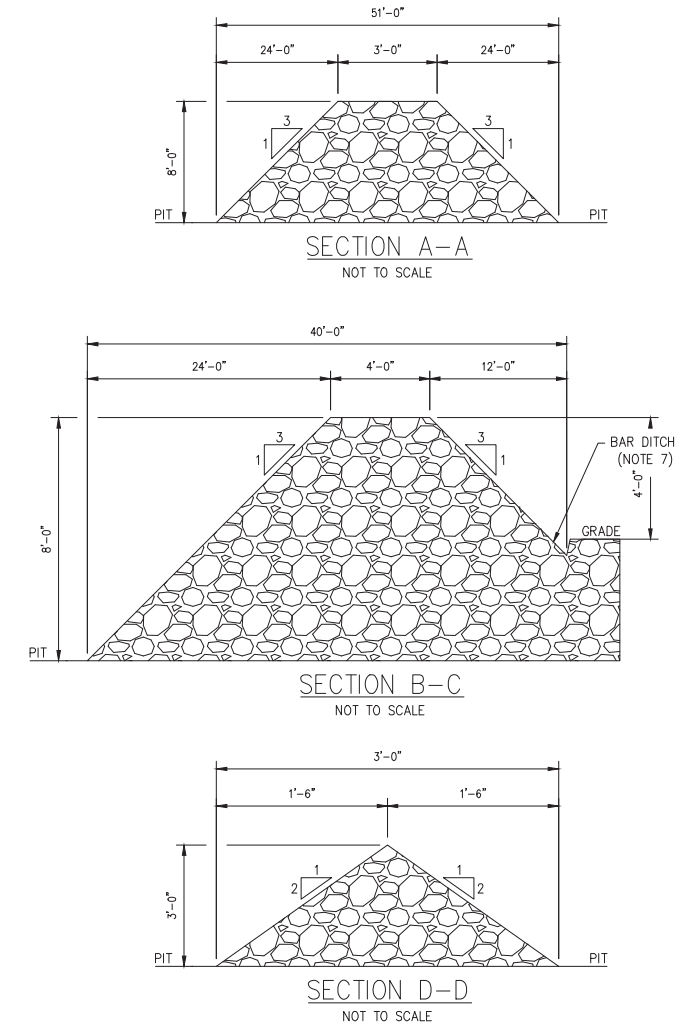
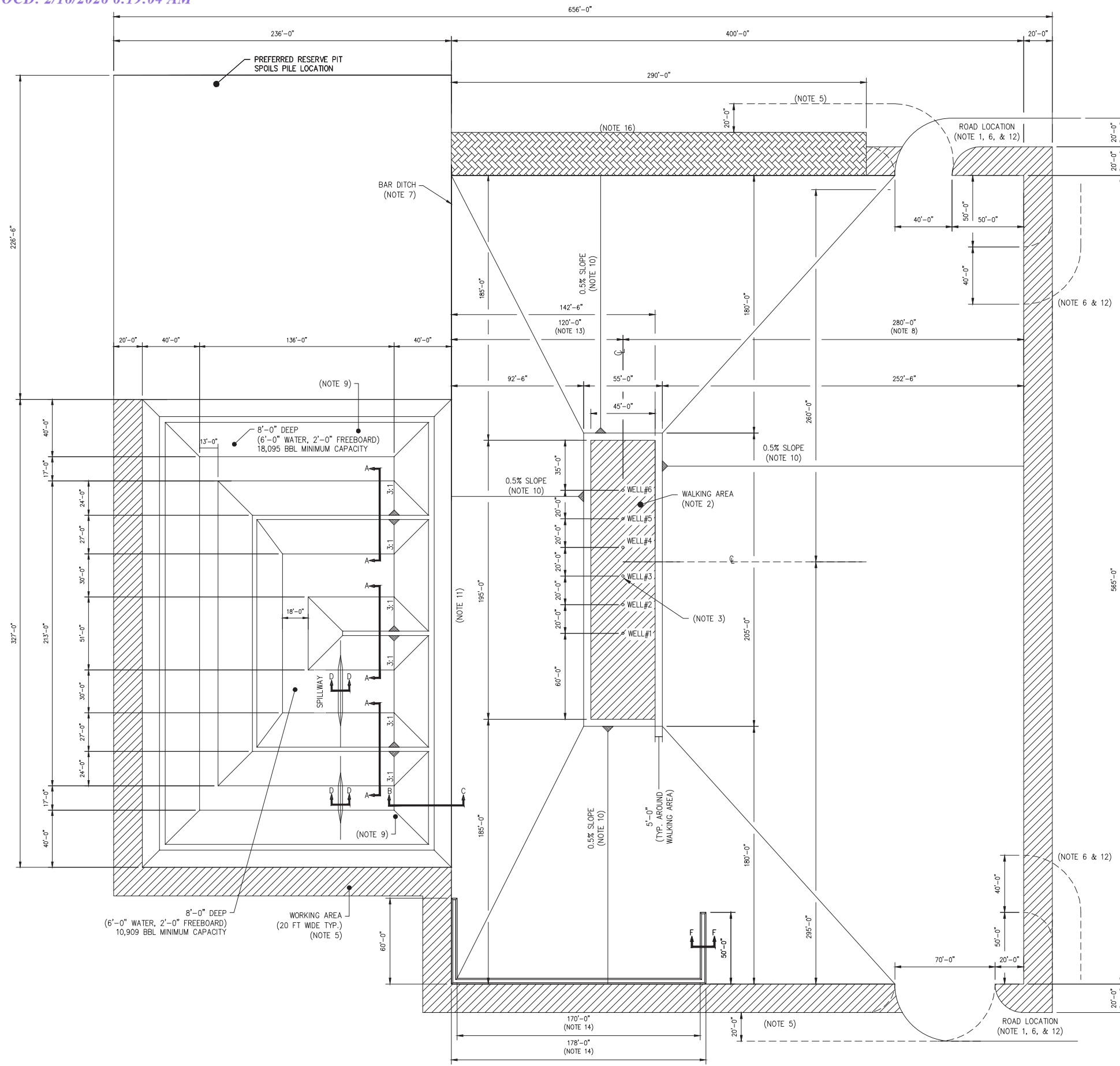

- NOTES:**
- PRIMARY PAD ENTRANCE MUST BE ON WEST OR EAST SIDE OF PAD FOR DRILLING LAYOUT.
 - SEE GEO-TECHNICAL INVESTIGATION REPORT FOR COMPACTION RECOMMENDATION. SEE DRILLING MAT LAYOUT FOR DETAILS.
 - FOR COMPLETIONS GRAVEL LOCATIONS, SEE DWG. FACTSTD-COMGRVL-CIV-PVD-MCB-0001-01.
 - PERMITS NEEDED FOR SHADED WORK AREA AND 30'X290' OPS KICK OUT.
 - ROAD CAN COME FROM EITHER THE NORTH OR SOUTH DIRECTION DEPENDING ON LEASE ORIENTATION.
 - SECONDARY ACCESS ROAD IS REQUIRED FOR COMPLETIONS DRIVE-THROUGH. SECONDARY ACCESS ROAD CAN BE EITHER ON EAST/WEST EDGE OF PAD OR SOUTH EDGE OF PAD, BUT MUST BE OPPOSITE OF PRIMARY PAD ENTRANCE (REF. NOTE 1) FE MUST CONSULT D&C ADVISOR TO COMPLETE P/MOC IF SECONDARY ROAD IS NOT FEASIBLE.
 - BAR DITCHING TO BE PROVIDED BETWEEN PAD AND RESERVE PIT.
 - DIMENSION SOUTH OF THE WELLS CAN BE REDUCED TO 260' IF BASIS OF DESIGN IS CONVENTIONAL FRAC OPERATIONS. MOC REQUIRED.
 - PAINT 8' LONG PIT LEVEL MARKERS EVERY 2' FROM THE BOTTOM LABEL BY THE LENGTH OF THE INCLINE FROM THE BOTTOM OF THE PIT.
 - PREDOMINANT DRAINING DIRECTION TO BE FIELD-DETERMINED BASED ON LOCAL TOPOGRAPHY.
 - FOR THE 6-WELL PAD, DISTANCE IN BETWEEN WELLS IS 20'-0".
 - 0.5% CROWN THROUGH CENTERLINE OF ROAD ENTRANCE TO THE PAD FOR WATER RUN OFF.
 - DIMENSION NORTH OF THE WELLS CAN BE INCREASED TO 150' IF BASIS OF DESIGN IS ESP AS THE ARTIFICIAL LIFT METHOD. MOC REQUIRED.
 - NORTH BERM WALL MUST BE OFFSET BY 5'-0" TO THE SOUTH FOR ESP WELLS.
 - AN ADDITIONAL CONTAINMENT BERM NOT REQUIRED IF PAD BOUNDARY BERM IS PLANNED.
 - LOCATION WILL DEPEND ON FE INFRASTRUCTURE AND INCLUDE PRODUCTION OPERATIONS EQUIPMENT LIKE FL, GL, WELL PANELS, CHEMICALS, ESP DRIVES, POWER POLES, ETC. THIS AREA REQUIRES ONLY CLEARING, BALANCING, AND FINISHING.

PLOT DATE: 04/11/2024, FILE NAME: 2020-PADSWELLS-MECH-CIV-PVD-MCB-0001-12
LEASE NUMBER
ALTERNATE DWG NUMBER API NUMBER

REVISIONS			
0	APPROVED FOR CONSTRUCTION BASIN DESIGN, DRF 21103 CSD 04/05/21	EV	CK/HT
1	APPROVED FOR CONSTRUCTION BASIN DESIGN, DRF 21252 EV 08/31/21	EB	UG/OS
2	APPROVED FOR CONSTRUCTION BASIN DESIGN, DRF 22011 EV 04/26/22	QY	QY
3	APPROVED FOR CONSTRUCTION BASIN DESIGN, DRF 22199 EV 07/19/22	-	QYTY
4	APPROVED FOR CONSTRUCTION 3S E&D, DRF 22589 JL 05/04/23	3S	QYTY
5	APPROVED FOR CONSTRUCTION 3S E&D, DRF 23912 CLG 02/06/24	3S	QYTY
6	APPROVED FOR CONSTRUCTION 3S E&D, DRF 23913 CLG 04/11/24	3S	QYTY

AFC
APPROVED FOR CONSTRUCTION

Chevron U.S.A. Inc.
DR. JLH
ENG. KVPY

FACTORY STANDARD DRAWINGS
PROJECT DESCRIPTION — COUNTY, STATE
CIVIL — FACTORY STANDARD 6 WELL PAD PLAN — OPEN LOOP
FACTSTD-6WPADOPN-CIV-PVD-MCB-0001-01

SHEET CIV012

LEGEND	
	PROPOSED PAD/PIT
	PROPOSED CLEAR LIMITS
	EDGE OF PROPOSED ACCESS ROAD
	CL PROPOSED ACCESS ROAD
	EXISTING PAD/ROAD/EASEMENT
	PROPOSED PAD/ROAD/EASEMENT
	EXISTING PIPELINE
	EXISTING OVERHEAD POWERLINE
	SECTION LINE
	TOWNSHIP/RANGE LINE
	FOUND MONUMENT

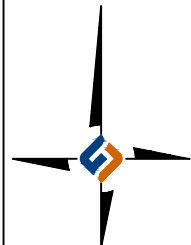
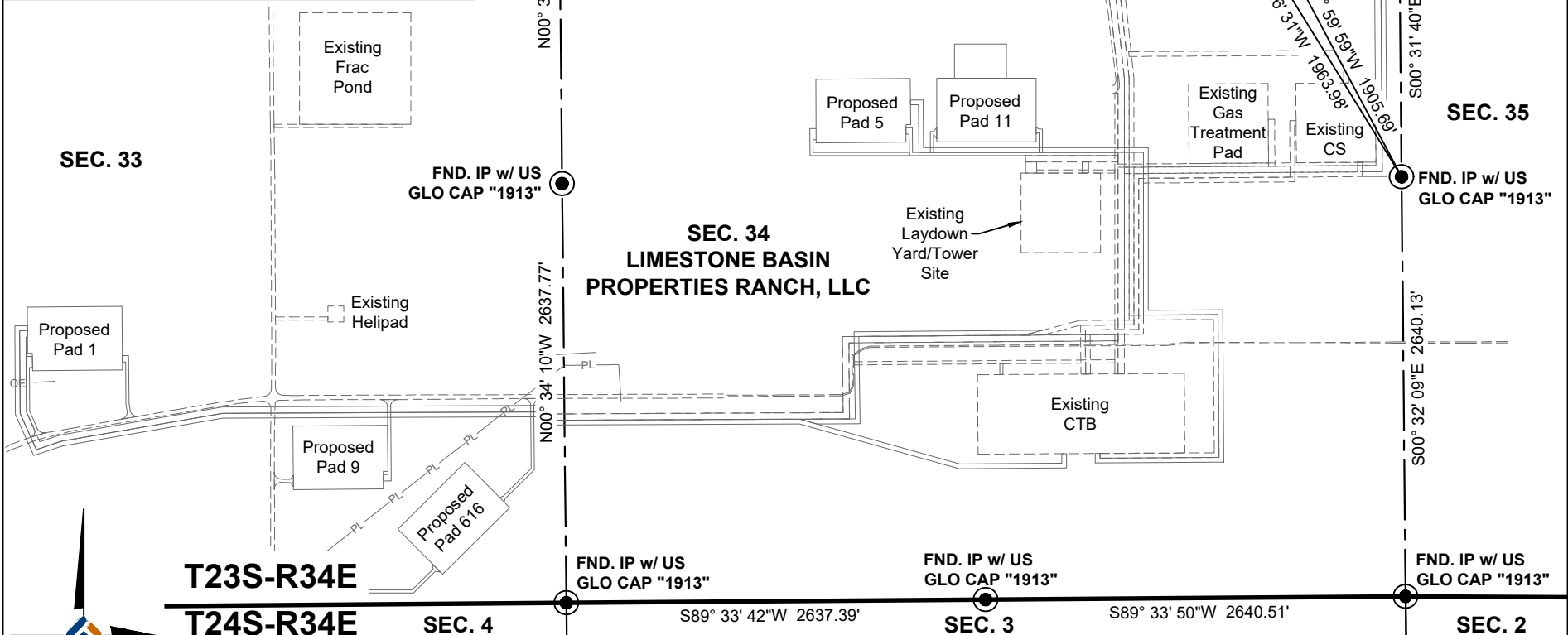

T23S-R34E
T24S-R34E

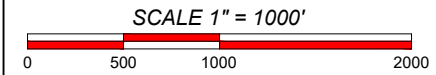

REVISIONS

AFE: CUSA-240807



I, THE UNDERSIGNED, DO HEREBY CERTIFY THAT THE SURVEY INFORMATION FOUND ON THIS PLAT WAS DERIVED FROM FIELD NOTES OR ELECTRONIC DATA OF AN ACTUAL ON-THE-GROUND SURVEY MADE BY ME OR UNDER MY SUPERVISION AND IS TRUE AND CORRECT TO THE BEST OF MY KNOWLEDGE AND BELIEF. NO WARRANTY IS MADE OR INTENDED FOR THE LOCATION OF ANY OR ALL EASEMENTS THAT MAY EXIST WITHIN THE BOUNDS OF THIS SURVEY.

Chad Harcrow
CHAD HARCROW RPLS #17777
PROJECT MANAGER: VHV
DRAWN BY: AMR

11/15/24
DATE
SURVEY DATE: 09/11/24
SHEET 2 OF 4

PAD PLAT
ZION PAD 13
CHEVRON U.S.A. INC.
SECTION 34, T23S-R34E
LEA COUNTY, NEW MEXICO



HOLLAND
LAND RESOURCES
2028 E. BEN WHITE BLVD., SUITE 240-2012
AUSTIN, TEXAS 78741
Texas Firm No. 10194865
ph. 281.826.1964
email: accounting@holland-lr.com
Fort Worth - Denver - Houston - Midland
Oklahoma City - Pittsburgh

(NAD 27 NM E)

CLEAR LIMITS CORNER 1

X=772,625.54
Y=462,116.12
LAT.32.267394°N
LONG.-103.451327°W

CLEAR LIMITS CORNER 2

X=773,199.04
Y=462,116.12
LAT.32.267381°N
LONG.-103.449472°W

CLEAR LIMITS CORNER 3

X=773,199.04
Y=461,880.12
LAT.32.266733°N
LONG.-103.449478°W

CLEAR LIMITS CORNER 4

X=773,149.04
Y=461,880.12
LAT.32.266734°N
LONG.-103.449640°W

CLEAR LIMITS CORNER 5

X=773,149.04
Y=461,460.12
LAT.32.265579°N
LONG.-103.449651°W

CLEAR LIMITS CORNER 6

X=772,514.04
Y=461,460.12
LAT.32.265594°N
LONG.-103.451705°W

CLEAR LIMITS CORNER 7

X=772,514.04
Y=461,900.12
LAT.32.266803°N
LONG.-103.451693°W

CLEAR LIMITS CORNER 8

X=772,625.54
Y=461,900.12
LAT.32.266801°N
LONG.-103.451333°W

NW RESERVE PIT CORNER

X=772,645.54
Y=462,096.12
LAT.32.267339°N
LONG.-103.451263°W
ELEV. 3454'

NE RESERVE PIT CORNER

X=772,972.54
Y=462,096.12
LAT.32.267331°N
LONG.-103.450205°W
ELEV. 3453'

SE RESERVE PIT CORNER

X=772,972.54
Y=461,880.12
LAT.32.266738°N
LONG.-103.450211°W
ELEV. 3455'

SW RESERVE PIT CORNER

X=772,645.54
Y=461,880.12
LAT.32.266745°N
LONG.-103.451268°W
ELEV. 3455'

NW PAD CORNER

X=772,534.04
Y=461,880.12
LAT.32.266748°N
LONG.-103.451629°W
ELEV. 3455'

NE PAD CORNER

X=773,129.04
Y=461,880.12
LAT.32.266734°N
LONG.-103.449704°W
ELEV. 3454'

SE PAD CORNER

X=773,129.04
Y=461,480.12
LAT.32.265635°N
LONG.-103.449715°W
ELEV. 3454'

SW PAD CORNER

X=772,534.04
Y=461,880.12
LAT.32.265648°N
LONG.-103.451640°W
ELEV. 3455'

**ZN 34 3 FED COM
NO. 419H WELL**

X=772,809.04
Y=461,760.12
LAT.32.266412°N
LONG.-103.450743°W
ELEV. 3455'
653' FNL, 571' FEL

**ZN 34 3 FED COM
NO. 619H WELL**

X=772,829.04
Y=461,760.12
LAT.32.266411°N
LONG.-103.450678°W
ELEV. 3455'
653' FNL, 551' FEL

**ZN 34 3 FED COM
NO. 420H WELL**

X=772,849.04
Y=461,760.12
LAT.32.266411°N
LONG.-103.450613°W
ELEV. 3455'
653' FNL, 531' FEL

**ZN 34 3 FED COM
NO. 620H WELL**

X=772,869.04
Y=461,760.12
LAT.32.266410°N
LONG.-103.450549°W
ELEV. 3456'
653' FNL, 511' FEL

**ZN 34 3 FED COM
NO. 421H WELL**

X=772,889.04
Y=461,760.12
LAT.32.266410°N
LONG.-103.450484°W
ELEV. 3455'
653' FNL, 491' FEL

**ZN 34 3 FED COM
NO. 621H WELL**

X=772,909.04
Y=461,760.12
LAT.32.266409°N
LONG.-103.450419°W
ELEV. 3455'
653' FNL, 471' FEL

REVISIONS

AFE: CUSA-240807



I, THE UNDERSIGNED, DO HEREBY CERTIFY THAT THE SURVEY INFORMATION FOUND ON THIS PLAT WAS DERIVED FROM FIELD NOTES OR ELECTRONIC DATA OF AN ACTUAL ON-THE-GROUND SURVEY MADE BY ME OR UNDER MY SUPERVISION AND IS TRUE AND CORRECT TO THE BEST OF MY KNOWLEDGE AND BELIEF. NO WARRANTY IS MADE OR INTENDED FOR THE LOCATION OF ANY OR ALL EASEMENTS THAT MAY EXIST WITHIN THE BOUNDS OF THIS SURVEY.

Chad Harcrow

11/15/24

CHAD HARCROW RPLS #17777

DATE

PROJECT MANAGER: VHV
DRAWN BY: AMR

SURVEY DATE: 09/11/24
SHEET 3 OF 4

**PAD PLAT
ZION PAD 13
CHEVRON U.S.A. INC.
SECTION 34, T23S-R34E
LEA COUNTY, NEW MEXICO**



HOLLAND
LAND RESOURCES
2028 E. BEN WHITE BLVD., SUITE 240-2012
AUSTIN, TEXAS 78741
Texas Firm No. 10194865
ph. 281.826.1964
email: accounting@holland-ir.com
Fort Worth - Denver - Houston - Midland
Oklahoma City - Pittsburgh

PROPOSED PAD		
Line #	Length	Direction
L1	400.08	S00° 00' 00"E
L2	595.12	N90° 00' 00"W
L3	400.08	N00° 00' 00"E
L4	595.12	N90° 00' 00"E

PROPOSED ACCESS ROAD		
Line #	Length	Direction
L9	789.81	N90° 00' 00"E
L10	100.02	N00° 00' 00"E
L11	30.01	N90° 00' 00"W

PROPOSED ACCESS ROAD		
Line #	Length	Direction
L12	75.01	N00° 00' 00"E
L13	30.01	N90° 00' 00"E

PROPOSED RESERVE PIT		
Line #	Length	Direction
L5	327.06	N90° 00' 00"E
L6	216.04	S00° 00' 00"E
L7	327.06	N90° 00' 00"W
L8	216.04	N00° 00' 00"E

POINT OF BEGINNING
 X=772,369.38
 Y=461,450.12
 LAT.32.265569°N
 LONG.-103.452173°W

POINT OF BEGINNING
 X=772,504.04
 Y=461,460.12
 LAT.32.265594°N
 LONG.-103.451737°W

POINT OF ENDING
 X=773,129.04
 Y=461,550.11
 LAT.32.265827°N
 LONG.-103.449713°W

POINT OF ENDING
 X=772,534.04
 Y=461,535.12
 LAT.32.265799°N
 LONG.-103.451638°W

NOTES:

1. This plat does not represent a boundary survey and is for the exclusive use of Chevron U.S.A. Inc., boundary lines and monuments shown hereon are for reference use only. Coordinates shown are based on the New Mexico Coordinate System, State Plane NAD 27, New Mexico East Zone (3001), U.S. survey foot. Latitude and longitude are based on WGS84. Distances shown are ground distances.

2. Location of existing pipelines shown are based on standard pipeline locating equipment, scars and pipeline markers, every effort was made to locate and verify said pipelines. However caution should be exercised when performing work as pipelines and other hazards, such as fiber optic cables, PVC pipelines, etc., may exist on site that could not be located. As such be advised that New Mexico law requires that contractors contact New Mexico One Call at www.nm811.org for assistance in locating and marking underground utilities prior to construction.



I, THE UNDERSIGNED, DO HEREBY CERTIFY THAT THE SURVEY INFORMATION FOUND ON THIS PLAT WAS DERIVED FROM FIELD NOTES OR ELECTRONIC DATA OF AN ACTUAL ON-THE-GROUND SURVEY MADE BY ME OR UNDER MY SUPERVISION AND IS TRUE AND CORRECT TO THE BEST OF MY KNOWLEDGE AND BELIEF. NO WARRANTY IS MADE OR INTENDED FOR THE LOCATION OF ANY OR ALL EASEMENTS THAT MAY EXIST WITHIN THE BOUNDS OF THIS SURVEY.

Chad Harcrow 11/15/24
 CHAD HARCROW RPLS #17777 DATE
 PROJECT MANAGER: VHV SURVEY DATE: 09/11/24
 DRAWN BY: AMR SHEET 4 OF 4

PAD PLAT
ZION PAD 13
CHEVRON U.S.A. INC.
SECTION 34, T23S-R34E
LEA COUNTY, NEW MEXICO

HOLLAND
 LAND RESOURCES
 2028 E. BEN WHITE BLVD., SUITE 240-2012
 AUSTIN, TEXAS 78741
 Texas Firm No. 10194865
 ph. 281.826.1964
 email: accounting@holland-lr.com
 Fort Worth - Denver - Houston - Midland
 Oklahoma City - Pittsburgh

REVISIONS
AFE: CUSA-240807

Appendix E

Operating and Maintenance Plan

**ZN 34 3 FED COM (Pad 13) Temporary Pit
Section 34 of T23S, R34E, Lea County**

Appendix E – Operating and Maintenance Plan

ZN 34 3 FED COM (Pad 13) Temporary Pit

The Operator and Rig Contractor will operate and maintain the Temporary Pit to contain liquids and solids, maintain the integrity of the liner system in a manner that prevents contamination of fresh water and protects public health and the environment as described below.

The operation of the Temporary Pit is summarized below:

- Prior to arrival of the drilling rig, the separate pit sections are filled with the fluid required for drilling operations of the wells on the well pad. Typically, these fluids are a low chloride brackish water and a high chloride saturated brine.
- During open loop drilling operations, fluid is pulled from one end of the Temporary Pit and sent to the rig pumps to be transferred downhole as the drilling fluid. Upon returning to the surface, the fluid and associated drilled solids flow to the opposite end of the Temporary Pit.
- When conducting Closed Loop drilling activities, the Temporary Pit may be utilized for cuttings disposal for purposes of maintaining mud weight, mitigating downhole hazards, and managing other unforeseen circumstances. The Temporary Pit is only to be utilized in conjunction with Closed Loop drilling when drilling activities are done using Water Based Drilling Fluids. In this circumstance, drilled solids are separated from the drilling fluid with solids control equipment and then moved to the Temporary Pit.
- During well cementing operations, if the low chloride fluid in the Temporary Pit meets specifications set by the Operator and Cementing Contractor, that fluid will be used as mix water for the blending of the cement slurry. During cementing operations, excess cement returns may be placed in the Temporary Pit.
- Throughout well construction, if the fluid in the Temporary Pit meets the specifications set by the Operator and Rig Contractor, that fluid may be used as rig water for component cleaning and engine cooling.
- If downhole problems occur during drilling operations, such as fluid losses or waterflows, the Temporary Pit is used to assist with fluid management into and out of the well. Transfer pumps and hoses are used to move these fluids.
- After the drilling rig is mobilized off the well pad, any remaining fluids in the Temporary Pit will be removed and reused, recycled, or disposed of in a manner consistent with Division rules.

The operation of the Temporary Pit will follow the requirements listed below:

- All cuttings placed into the Temporary Pit will be produced and disposed of within the boundaries of one single lease, pursuant to the Pit Rule definition of “Onsite”.
- The Operator will not discharge into or store any hazardous waste (as defined by 40 CFR 261 and NMAC 19.15.2.7.H.3) in the pits.
- If the pit liner’s integrity is compromised above the water line, then the Operator will repair the damage within 48 hours of discovery.
- If the pit develops a leak, or if any penetration of the pit liner occurs below the liquid’s surface, then the Operator shall notify the appropriate division office pursuant to the requirements of 19.15.29 NMAC, remove all liquid above the damage or leak within 48 hours of discovery, and repair the damage or replace the pit liner as applicable.
- The injection or withdrawal of liquids from a pit is accomplished through a header, diverter or other hardware that prevents damage to the liner by erosion, fluid jets or impact from installation and removal of hoses or pipes.
- Engineering drawings demonstrate that the elevation and slopes of the pit prevent the collection of surface water run-on.
- The Operator will maintain on site an oil absorbent boom to contain and remove oil from the pit’s surface.
- The Operator will maintain the pit free of miscellaneous solid waste or debris.
- The Operator will maintain at least two feet of freeboard for the Temporary Pit. If, during extenuating circumstances, a freeboard of less than two feet is required, then a log will be maintained describing such circumstances.
- The Operator will remove all free liquids from the surface of a temporary pit within 30 days from the date the Operator releases the last drilling or workover rig associated with the relevant pit permit. The Operator will note the date of the drilling or workover rig’s release on form C-105 or C-103 upon well or workover completion.

Appendix F

Closure Plan

**ZN 34 3 FED COM (Pad 13) Temporary Pit
Section 34 of T23S, R34E, Lea County**

Appendix F – Closure Plan ZN 34 3 FED COM (Pad 13) Temporary Pit

Discussion of Onsite Cuttings Disposal

The proposed Temporary Pit will contain drill cuttings from the vertical sections of wells 419H, 420H, 421H, 619H, 620H, 621H. All cutting from vertical drilling will be produced and disposed of within the boundaries of one single lease, pursuant to the Pit Rule definition of “Onsite”. The disposal and closure activities will take place within the design footprint of the Temporary Pit. Proposed closure operations will be conducted in accordance with the Closure and Site Reclamation Requirements detailed in 19.15.17.13 NMAC.

Closure Notice

If planned activities deviate from this Closure Plan, an updated Closure Plan will be submitted to the Division for approval prior to initiating any closure activities.

The Operator will notify the Bureau of Land Management at least 72 hours, but not more than one week, prior to any closure activities as per approved sundry Conditions of Approval. This notice will include the project name and location description.

The Operator shall additionally notify the district office verbally and in writing at least 72 hours, but not more than one week, prior to any closure operation. This notice will include the Operator’s name and the location to be closed by unit letter, section, township, and range.

Protocols and Procedures

1. The Operator will remove all liquids from the Temporary Pit and either:
 - a. Dispose of the liquids in a division-approved facility,
 - or
 - b. Recycle, reuse or reclaim the water for reuse in drilling and stimulation.
2. A five-point (minimum) composite sample will be collected from the contents of the Temporary Pit and sent to an accredited laboratory for analysis of the constituents listed in Table 2 of 19.15.17.13 NMAC.
 - a. If any concentration is higher than limits listed in Table 2, blending calculations will be used to determine the amount of soil or non-waste material needed to blend with the pit contents to achieve the Table 2 limit. The mixing ratio of soil or non-waste material to pit contents shall not exceed 3:1.
 - b. If all constituent concentrations are less than or equal to the parameters listed in Table 2 of 19.15.17.13 NMAC, no mixing shall occur.
3. The Operator will conduct blending operations, as required, and conduct a paint filter liquids test to ensure that the contents of the former pit are sufficiently stabilized to support the cover materials.

4. Cover materials will be installed as described in 'Cover Design' (below).
5. Following the implementation of the cover design, the Operator will revegetate the area as outlined in 'Reclamation and Revegetation' (below).

Soil Cover Design

After blending with non-waste containing, uncontaminated, earthen material, the Operator will cover the former Temporary Pit according to the following procedure.

1. The contents of the former pit will be positively contoured ('turtle-backed') to promote drainage away from the former pit contents and reduce infiltration. Compaction of pit materials over time and as a result of placement of overburden will be taken into consideration.
2. A 20-mil string reinforced LLDPE geomembrane liner will be installed above the pit materials.
3. At least 4-feet of compacted, uncontaminated, non-waste containing earthen fill with chloride concentrations less than 600 mg/kg will be placed above the liner.
4. Either the background thickness of topsoil or 1-foot of suitable material to establish vegetation at the site, whichever is greater, will be placed over the earthen fill.
5. The location will be recontoured to match the pre-disturbance topography and prevent surface erosion and ponding.
6. The Operator will revegetate the area as described below in 'Reclamation and Revegetation'.

Closure Report

1. Within 60 days of closure completion, the Operator will submit a closure report on form C-144, with necessary attachments to document all closure activities including sampling results, information required by 19.15.17 NMAC, a plot plan including the exact location of the former pit, details of the cover design, and photographs.
2. In the closure report, the Operator will certify that all information in the report and attachments is correct and that the Operator has complied with all applicable closure requirements and conditions specified in the approved closure plan.
3. A steel marker will be placed at the location per the requirements in Subsection F of 19.15.17.13 NMAC.

Closure Timing

As discussed in **Variance 1**, the Operator proposes closure activities will be completed within a timeline not to exceed 1 year from the rig down move out (RDMO) date. This date will be noted on form C-105 or C-103, filed with the Division upon the well's completion.

Reclamation and Revegetation

The Operator will reclaim the disturbed area to a safe and stable condition that existed prior to oil and gas operations and that blends with the surrounding undisturbed area. Areas with ongoing production or drilling operations will not be reclaimed as described herein, but will be stabilized and maintained to minimize dust and erosion

For all areas relevant to the closure process that will not be used for production operations or future drilling, the Operator will:

1. Replace topsoils and subsoils to their original relative positions and regrade the area to achieve erosion control, long-term stability, preservation of surface water flow patterns, and prevent ponding.
2. Notify the Division when the surface grading work is complete.
3. Reseed the area with an appropriate seed mix in the first favorable growing season following closure. Reseeding and weed control measures will be taken, if necessary.
4. Notify the Division when reclamation is complete: vegetative cover has been established that reflects a life-form ratio of plus or minus 50 % of pre-disturbance levels and a total percent plant cover of at least 70 % of pre-disturbance levels, excluding noxious weeds.

Alternative to Closure in Place

In the event the concentration of any contaminant in the contents, after mixing with soil or non-waste material, is higher than constituent concentrations shown in 19.15.17.13 NMAC, then the waste shall be removed from the Temporary Pit and disposed of at a Division approved and Chevron approved off-site facility.

Appendix G

Evaluation of Unstable Conditions

**ZN 34 3 FED COM (Pad 13) Temporary Pit
Section 34 of T23S, R34E, Lea County**

Appendix G – Evaluation of Unstable Conditions ZN 34 3 FED COM (Pad 13) Temporary Pit

Summary

Figure 8 identifies the location of the proposed temporary pit with respect to Bureau of Land Management (BLM) mapped potential karst areas. The BLM categorizes all areas within the Carlsbad Field Office (CFO) as having either low, medium, high or critical karst occurrence potential based on geology, occurrence of known caves, density of karst features, and potential impacts to fresh water aquifers. The proposed Temporary Pit is mapped by BLM CFO in a “Low Potential” karst area.

The proposed Temporary Pit lies near the northeast margin of the Delaware Basin. Bedrock cropping out beneath the proposed project area is comprised of the Triassic-aged Dockum Group. Underlying the Dockum Group are the Dewey Lake redbeds. Both of these formations are composed chiefly of clastic (insoluble), non-karst-forming rocks. Beneath these formations are Permian-aged rocks of the Rustler and Salado Formations. These rocks contain significant beds of halite (i.e., rock salt) and anhydrite, making them susceptible to karst formation. The top of the Rustler Formation in the proposed project area is approximately 800 feet below the land surface (Crowl et al. 2011). Local karst potential is likely to be low.

Structurally, the region surrounding the proposed pit location is relatively undeformed, with a 0 to 3 percent slope, and the nearest mapped quaternary fault is approximately 110-miles to the west (USGS 2023).

Dissolution Features Evident on Aerial Imagery

The nearest apparent dissolution features to the proposed location are (**Figure 11**):

- San Simon Sink, and the associated San Simon Swale are approximately 3 miles northeast of the proposed pit location.
- ~15 miles southwest of the proposed pit location is an area with small (<500 feet in diameter) depressions.
- Bell Lake Sink is approximately 8-miles west of the proposed location.

Depth to Karst-Forming rocks

Figure G.1 shows a stratigraphic section of the formations beneath the proposed pit. The upper 1,000 feet of subsurface consists of insoluble, clastic material. These deposits are underlain by soluble, karst-forming strata.

Surface to ~1,000 feet: Based on a review of available literature for the region, no significant intervals of soluble rocks are present in the Quaternary and Triassic deposits that constitute the upper ~1,000 feet of subsurface. Because this material is largely

insoluble, the potential for karst features to form within this interval is very low (Lucas and Anderson, 1993). Deeper formations at >1,000 feet: The top of the Rustler Formation is approximately 400-feet thick beneath the surface at the location of the proposed pit (Nicholson and Clebsch 1961). The Rustler Formation overlies the Salado Formation. These formations both contain thick, highly soluble beds of anhydrite and halite. The Bell Lake Sink, San Simon Swale, and San Simon Sink formed by the dissolution of salt from these deep formations. The resulting surface subsidence (due to deep dissolution) is a very slow process that has been ongoing for millions of years to form these large depressions (Bachman, 1973).

Period	Formation	Thickness (ft)		Description
Quaternary		100		Unconsolidated eolian and unconsolidated to partially consolidated alluvial deposits
Triassic	Chinle	200		Red shales and thinly interbedded sandstone
	Santa Rosa	200 - 300		Sandstone and interbedded siltstone and red shale
Permotriassic	Quartermaster (Dewey Lake)	560		Mudstone, siltstone, claystone, and interbedded sandstone
Permian	Rustler	400		Anhydrite, halite, dolomite, sandy siltstone, and polyhalite

Figure G.1: Stratigraphic section beneath the location of the proposed temporary pit (Nicholson and Clebsch 1961)

Mitigation of Karst Potential

Not applicable; however, the following commitments will be applied as a best practice in development of the proposed pit.

General Construction:

- No blasting
- The BLM, Carlsbad Field Office, will be informed immediately if any subsurface drainage channels, cave passages, or voids are penetrated during construction, and no additional construction shall occur until clearance has been issued by the Authorized Officer.
- All linear surface disturbance activities will avoid sinkholes and other karst features, if they are identified during construction, to lessen the possibility of encountering near surface voids during construction, minimize changes to runoff, and prevent untimely leaks and spills from entering the karst drainage system.
- All spills or leaks will be reported to the BLM immediately for their immediate and proper treatment.

Pad Construction:

- The pad will be constructed and leveled by adding the necessary fill and caliche –no blasting.
- The entire perimeter of the well pad will be bermed to prevent oil, salt, and other chemical contaminants from leaving the well pad.
- The compacted berm shall be constructed at a minimum of 12 inches high with impermeable mineral material (e.g., caliche).
- No water flow from the uphill side(s) of the pad shall be allowed to enter the well pad.
- The topsoil stockpile shall be located outside the bermed well pad.
- Topsoil, either from the well pad or surrounding area, shall not be used to construct the berm.
- No storm drains, tubing or openings shall be placed in the berm.
- If fluid collects within the bermed area, the fluid must be vacuumed into a safe container and disposed of properly at a state approved facility.
- The integrity of the berm shall be maintained around the surfaced pad throughout the life of the well and around the downsized pad after interim reclamation has been completed.
- Any access road entering the well pad shall be constructed so that the integrity of the berm height surrounding the well pad is not compromised (i.e. an access road crossing the berm cannot be lower than the berm height).
- Following a rain event, all fluids will be vacuumed off of the pad and hauled off-site and disposed at a proper disposal facility.

References

Bachman. 1973. Surficial features and late Cenozoic history in southeastern New Mexico: US Geological Survey, Open-File Report USGS-4339-8, Denver CO.

Crowl, W. J., D. E. Hulse, and G. Tucker, P.E., 2011. NI 43-101 Technical Report Prefeasibility Study for the Ochoa Project, Lea County, New Mexico. Prepared for IC Potash Corporation by Gustavsen and Associates, December 30, 2011, 301 p.

Lucas, S.G., & Anderson, O.J. 1993. Stratigraphy of the Permian-Triassic boundary in southeastern New Mexico and west Texas. *Carlsbad Region (New Mexico and West Texas)*.

Nicholson, Alexander, Jr. and Clebsch, Alfred, Jr. 1961. Ground-Water Report 6 - Geology and Ground-Water Conditions in Southern Lea County, New Mexico, United States Geological Survey in cooperation with the New Mexico Institute of Mining and Technology, State Bureau of Mines and Mineral Resources Division and the New Mexico State Engineer.

U.S. Geological Survey and New Mexico Bureau of Mines and Mineral Resources, Quaternary fault and fold database for the United States, accessed February 25, 2023 at: <https://www.usgs.gov/natural-hazards/earthquake-hazards/faults>.

Attachments

Baseline Ecological Assessment / Surface Owner Agreement

**ZN 34 3 FED COM (Pad 13) Temporary Pit
Section 34 of T23S, R34E, Lea County**



Chevron U.S.A. Inc.

BASELINE ECOLOGICAL ASSESSMENT

Zion Development Area

June 13, 2019

ENVIRONMENTAL FIELD SURVEY
ZION DEVELOPMENT AREA

**BASELINE ECOLOGICAL
ASSESSMENT**

Zion Development Area

Prepared for:

Lee Higgins
Chevron North America Exploration &
Production Company
1400 Smith St 41135
Houston, Texas 77002

Prepared by:

Arcadis U.S., Inc.
1004 N. Big Spring Street
Suite 300
Midland
Texas 79701
Tel 432 687 5400

Our Ref.:

B0048914.0000

Date:

June 13, 2019

This document is intended only for the use of the individual or entity for which it was prepared and may contain information that is privileged, confidential and exempt from disclosure under applicable law. Any dissemination, distribution or copying of this document is strictly prohibited.

ENVIRONMENTAL FIELD SURVEY
ZION DEVELOPMENT AREA

This page intentionally left blank.

ENVIRONMENTAL FIELD SURVEY
ZION DEVELOPMENT AREA

CONTENTS

1 Introduction 1

 1.1 Study Area..... 1

 1.2 Methods..... 1

2 Existing land use, infrastructure, and development..... 3

3 Vegetation..... 5

 3.1 Recommendations..... 6

4 Wildlife 7

 4.1 Migratory Birds 7

 4.2 Threatened and Endangered Species..... 8

 4.3 Recommendations..... 9

5 Hydrology..... 11

 5.1 Surface Hydrology 11

 5.1.1 Floodplain..... 11

 5.1.2 Surface Waterbody Features 12

 5.1.3 Wetland and Riparian Areas 12

 5.2 Findings and Recommendation..... 12

6 Cultural resources 15

 6.1 File Search 15

 6.2 Recommendations..... 16

7 Recommendations..... 19

 7.1 Vegetation 19

 7.2 Migratory Birds 19

 7.3 Surface Waterbody Features 19

 7.4 Cultural Resources..... 19

8 References 21

ENVIRONMENTAL FIELD SURVEY
ZION DEVELOPMENT AREA

TABLES

Table 1	Vascular Plant List for the Study Area	5
Table 2	May 2019 Nest Survey Results for the Study Area	8
Table 3	Annotated County List of Rare Avian Species in Lea County, New Mexico.....	9
Table 4	Species-Specific Nest Buffers in Lea County, New Mexico.....	9
Table 5	Previous Cultural Projects in the Study Area.....	15

FIGURES

Figure 1	Site Vicinity
Figure 2	Study Area – Aerial View
Figure 3	Surface Water Hydrology
Figure 4	Public Receptors
Figure 5	Bird Nests
Figure 6	Avoidance Areas

APPENDICES

Appendix A	Threatened and Endangered Species of Potential Occurrence in Lea County, New Mexico / Biota Information System of New Mexico
Appendix B	USFWS Official Letter for Threatened and Endangered Species of Potential Occurrence in the Study Area
Appendix C	Photographs
Appendix D	Completed Arid West Ephemeral and Intermittent OHWM Data

ENVIRONMENTAL FIELD SURVEY
ZION DEVELOPMENT AREA

ACRONYMS AND ABBREVIATIONS

Arcadis	Arcadis U.S., Inc.
BEA	Baseline Ecological Assessment
BISON-M	Biota Information System of New Mexico
ESA	Endangered Species Act
BMP	Best Management Practice
Chevron	Chevron U.S.A. Inc.
CWA	Clean Water Act
FEMA	Federal Emergency Management Agency
GIS	geographic information system
GLONASS	Global Navigation Satellite System
GPS	global positioning system
IPaC	Information for Planning and Consultation
LPC	lesser prairie-chicken
MBTA	Migratory Bird Treaty Act
NHD	National Hydrography Dataset
NMAC	New Mexico Administrative Code
NMCRIS	New Mexico Cultural Resources Information System
NMED	New Mexico Environment Department
NPDES	National Pollutant Discharge Elimination System
NRCS	Natural Resource Conservation Service
NWI	National Wetland Inventory
OHWM	ordinary high water mark
PC	point count
RPW	Relatively Permanent Waterway
Study Area	Zion Development Area
T&E	Threatened and Endangered
TNW	Traditional Navigable Waterway
TSC	timed species counting
UNKN	unknown

ENVIRONMENTAL FIELD SURVEY
ZION DEVELOPMENT AREA

U.S.	United States
USC	United States Code
USACE	U.S. Army Corp of Engineers
USFWS	U.S. Fish & Wildlife Service

ENVIRONMENTAL FIELD SURVEY ZION DEVELOPMENT AREA

1 INTRODUCTION

Chevron North America Exploration & Production Company's Mid-Continent Business Unit (Chevron MCBU) is proposing to expand production in Lea County, New Mexico. Arcadis U.S., Inc. (Arcadis) conducted a Baseline Ecological Assessment (BEA) for the Zion Development Area in Lea County, New Mexico (**Figure 1**).

A high-level desktop constraints analysis was conducted in 2016 (Tetra Tech) of the South Lea Development Area, which is subdivided into multiple development areas including Rattlesnake Flat, Salado Draw, Cotton Draw, Rock Lake, Red Hills, Brininstool, and Talco. The Zion Development Area includes portions of Brininstool and Red Hills Development Areas. The 2016 desktop constraints analysis provides information at a high level for the Brininstool and Red Hills Development Areas. The purpose of this report is to provide more specific information for public receptors, wildlife habitat, migratory birds, threatened and endangered species, surface hydrology, and cultural resources for the Zion Development Area.

1.1 Study Area

The Zion Development Area (Study Area) is located on private and state lands and is comprised of Sections 33 and 34 of Township 23 South, Range 34 East and Sections 3 and 4 of Township 24 South, Range 34 East (**Figure 2**). It encompasses approximately 2,550 acres northwest of the city of Jal in Lea County, New Mexico.

1.2 Methods

Arcadis conducted a desktop review of publicly available environmental databases and Geographic Information System (GIS) data. Resources reviewed include Google Earth Imagery, Biota Information System of New Mexico (BISON-M), restricted New Mexico Cultural Resources Information System (NMCRIS), National Hydrography Dataset, U.S. Fish and Wildlife Service (USFWS) National Wetlands Inventory, Federal Emergency Management Agency (FEMA) floodplain mapping, and the USFWS Information for Planning and Consultation (IpaC) website.

In addition to the desktop review, Arcadis conducted a field survey from May 13 to May 15, 2019 to confirm public receptors that were identified on aerial imagery during the desktop analysis, migratory bird presence/absence and nest surveys, and collect information on observed water features. A full aquatic resources delineation was not completed but the location and extent of water features, such as ephemeral drainages, was mapped and information on ordinary high water mark (OHWM) was collected.

Migratory bird presence/absence and nest surveys were conducted to collect information on general nesting activity, species diversity, and presence/absence of threatened and endangered (T&E) species within the Study Area. A team of two Arcadis biologists conducted the surveys by collecting data at twenty-four randomized point count locations throughout the Study Area, as well as by driving all access roads for potential raptor nests. To aid in navigation and data recording, each biologist used a Garmin GLO 2 receiver, which utilizes Global Positioning System (GPS) and Global Navigation Satellite System (GLONASS), paired to a smartphone with the ESRI Collector Application to record nest locations or other relevant resource features observed. In addition to GPS points collected at each 'finding', a picture was also collected and stored in-sync with the GPS point.

ENVIRONMENTAL FIELD SURVEY
ZION DEVELOPMENT AREA

The point count (PC) method paired with the timed species counting (TSC) method was utilized to assess for the presence/absence of T&E species throughout the Study Area. The area was broken into four quadrants and each quadrant contained six randomized PC locations. Each PC location was surveyed once at ten-minute intervals. Point Counts were conducted only in the morning (dawn until approximately four hours after dawn) and evening (approximately four hours before dusk to dusk), when birds are most active. Playback calls were utilized for all listed species, except for the Aplomado Falcon (*Falco femoralis septentrionalis*), during each PC. During the survey, any critical habitat for T&E species was also documented.

ENVIRONMENTAL FIELD SURVEY
ZION DEVELOPMENT AREA

2 EXISTING LAND USE, INFRASTRUCTURE, AND DEVELOPMENT

Based on review of aerial imagery and ground-truthing, the Study Area consists of oil and gas development and rangeland, intermixed with less developed areas. There is one residence and approximately 41 acres of state-owned land within Section 3 of the Study Area (**Figure 4**). According to Arcadis' habitat assessment, the less developed areas are dominated by mesquite shrubland and desert scrub with sparse grasses.

ENVIRONMENTAL FIELD SURVEY
ZION DEVELOPMENT AREA

This page intentionally left blank.

ENVIRONMENTAL FIELD SURVEY
ZION DEVELOPMENT AREA

3 VEGETATION

According to the U.S. Environmental Protection Agency (USEPA) Ecoregions Maps, the Study Area occurs within the Chihuahuan Desert Grasslands, located within the Chihuahuan Deserts ecoregion, which extends from southern New Mexico to west Texas (USEPA 2019a). The major vegetation communities within the Study Area are associated with loamy fine sands, and typically include an understory consisting of black grama, blue grama, sideoats grama, mesa dropseed, threeawn, buffalo grass, sand muhly, sand sage, yucca, snakeweed and mesquite. **Table 1** provides a list of plant species that occur in the Study Area.

Table 1 Vascular Plant List for the Study Area

Common Name	Scientific Name
AGAVACEAE CENTURY-PLANT FAMILY	
Soaptree Yucca	<i>Yucca elata</i>
CACTACEAE JUSS. CACTUS FAMILY	
Purple Prickly Pear	<i>Opuntia macrocentra</i>
Horse Crippler Cactus	<i>Echinocactus texensis</i>
Engelmann's Prickly Pear	<i>Opuntia engelmannii</i>
Cane Cholla, Tree Cholla	<i>Opuntia imbricate</i>
FABACEAE LINDL. LEGUME FAMILY	
Honey Mesquite	<i>Prosopis glandulosa</i>
ANACARDIACEAE LINDL. SUMAC FAMILY	
Littleleaf Sumac, Desert Sumac	<i>Rhus micorphylla</i>
ZYGOPHYLLACEAE R. BR. CALTROP FAMILY	
Creosotebush, Gobernadora	<i>Larrea tridentata</i>
Goathead, Puncturevine	<i>Tribulus terrestris</i>
VERBENACEAE J.St.-Hil. VERVAIN FAMILY	
Big Bract Verbena	<i>Verbena bracteata</i>
SCROPHULARIACEAE JUSS. FIGWORT FAMILY	
Sand Penstemon	<i>Penstemon arenicola</i>
ASTERACEAE / COMPOSITAE. ASTER FAMILY	
Collegeflower, Yellow Plainsman	<i>Hymenopappus flavescens</i>
Lemonscent	<i>Pectis angustifolia</i>
Plains Blackfoot	<i>Melampodium leucanthum</i>
Coulter's Horseweed	<i>Laennecia coulteri</i>
White Sagebrush, Gray Sagewort, Prairie Sage	<i>Artemisia ludoviciana</i>
Broom Snakeweed	<i>Gutierrezia sarothrae</i>

ENVIRONMENTAL FIELD SURVEY
ZION DEVELOPMENT AREA

Table 1 Vascular Plant List for the Study Area

Common Name	Scientific Name
POACEAE L. GRASS FAMILY	
Plains Bristlegrass	<i>Setaria vulpiseta</i>
Sand Dropseed	<i>Sporobolus cryptandrus</i>
Three Awn	<i>Aristida</i> sp.
Burrograss	<i>Scleropogon brevifolius</i>
Wolftail	<i>Lycurus phleoides</i>
Sideoats grama	<i>Bouteloua curtipendula</i>
LILIACEAE. LILY FAMILY	
Copper Zephyrlily	<i>Zephyranthes longifolia</i>
FAGACEAE. BEECH FAMILY	
Shinnery Oak, Havard Oak	<i>Quercus havardii</i>
ONAGRACEAE L. EVENING PRIMROSE	
Evening Primrose	<i>Oenothera</i>

3.1 Recommendations

When reclaiming areas that are not needed for daily operations on sandy soil areas, recommended mitigation is applying suitable native seed mixtures, such as sand lovegrass (*Eragrostis trichodes*), or laying down net straw erosion control blankets.

Since vegetation is difficult to establish, these areas should be seeded in the fall to take advantage of winter moisture and get a head start on annual weeds. If winter moisture is not available, these areas should be watered prior to spring long enough to establish a good root. Quick revegetation will protect these areas from wind and water erosion and will continue to provide habitat for the species reliant upon them.

ENVIRONMENTAL FIELD SURVEY ZION DEVELOPMENT AREA

4 WILDLIFE

Various bird, mammal, reptile and invertebrate species inhabit the Chihuahuan Deserts ecoregion in southeast New Mexico. Herbivorous mammals include black-tailed jackrabbit, desert cottontail, and numerous rodent species. Carnivores include coyote and gray fox. Two upland game bird species, scaled quail and mourning dove, were prevalent within the Study Area. Many species of songbird nest in the Study Area, with a much larger number that use the habitat during migration or for non-nesting activities. Common avian predators include northern harrier, Swainson's hawk, red-tailed hawk, and Harris's hawk. Numerous snake and lizard species also inhabit this ecosystem.

4.1 Migratory Birds

The Migratory Bird Treaty Act (MBTA) (16 United States Code [USC] §§703-712, omit §709) is the basis of migratory bird conservation in the United States (U.S) as well as internationally for some countries. The MBTA prohibits the "take" of "...any migratory bird, [and] any part, nest, or egg of any such bird..." (16 USC §703[a]). The term "take" is further defined in 50 Code of Federal Regulations §10.12 as, "... to pursue, hunt, shoot, wound, kill, trap, capture, or collect, or attempt to pursue, hunt, shoot, wound, kill, trap, capture, or collect..." Under the MBTA, destruction or disturbance of active nests that results in a take of migratory birds, their eggs, or hatchlings, including the abandonment of an active nest by breeding adults as a result of human disturbance, is prohibited.

Language within the statute is clear that, in the absence of a USFWS Incidental Take Permit, actions that result in the take of a protected species is in violation of the MBTA. However, the issuance of the M-Opinion (M-37050) by the Department of the Interior's Office of the Solicitor in December 2017 narrows MBTA take violations to include only "intentional" take in which actions to hunt, capture, kill or harass protected birds are "purposeful." The USFWS provided a guidance memorandum for the M-Opinion, M-067711, on April 11, 2019. M-067711 clarifies that "incidental take", or "take of birds resulting from an activity... when the underlying purpose of that activity is not to take birds" is not prohibited by the MBTA. A revised list of MBTA protected species includes nearly all birds native to the U.S. and is available through the USFWS website.

The PC survey identified a total of 29 migratory bird species, which include species such as cactus wren, northern mockingbird, western kingbird, great-tailed grackle, killdeer, great-crested flycatcher, red-winged blackbird, common ground dove, lark bunting, ash-throated flycatcher, willow flycatcher, Chihuahuan raven, loggerhead shrike, greater roadrunner, ladderback woodpecker, bullock's oriole, mourning dove, eastern meadowlark, pyrroluxia, scaled quail, Zion and olive-sided flycatcher. Raptors, such as American kestrel, Harris's hawk, Swainson's hawk, red-tailed hawk, and northern harrier, were also observed during the PC survey.

The nest survey identified a total of 15 nests; 10 passerine nests and 5 raptor nests. Each nest was evaluated for activity. Of the 15 nests, 10 were determined to be active. A summary of the findings is included in **Table 2** and shown on **Figure 5**. Representative photos of nests are provided in **Appendix C**.

ENVIRONMENTAL FIELD SURVEY
ZION DEVELOPMENT AREA

Table 2 May 2019 Nest Survey Results for the Study Area

Species	Species Code	Nest Status	Latitude	Longitude	Raptor? (Y/N)
Ladderback woodpecker	LAWO	Active	32.260649	-103.481253	N
Swainson's hawk	SWHA	Active	32.262028	-103.480738	Y
Cactus wren	CAWR	Inactive	32.255913	-103.472584	N
Harris's hawk	HAHA	Active	32.259016	-103.468872	Y
Western kingbird	WEKI	Active	32.259215	-103.469666	N
Cactus Wren	CAWR	Active	32.258344	-103.451931	N
Scissor-tailed flycatcher	STFL	Active	32.258344	-103.451931	N
Swainson's hawk	SWHA	Active	32.258344	-103.451931	Y
Cactus Wren	CAWR	Inactive	32.266894	-103.458735	N
Flycatcher sp.	UNKN	Inactive	32.266661	-103.457989	N
Swainson's hawk	Active	Active	32.253989	-103.479096	Y
Hawk sp.	UNKN	Inactive	32.266894	-103.459735	N
Mourning Dove	MODO	Active	32.257359	-103.463551	N
UNKN	UNKN	Inactive	32.257309	-103.46324	N
Swainson's hawk	SWHA	Active	32.255653	-103.467622	Y

Abbreviations:

* UNKN = Unknown

4.2 Threatened and Endangered Species

The 2016 desktop constraints analysis (Tetra Tech) determined two federally-listed and nine state-listed species have potential to occur in Lea County, New Mexico. The desktop constraints analysis report concluded that federally-listed species northern aplomado falcon and the state-listed species, Bell's Vireo (*Vireo bellii*) and Baird's Sparrow (*Ammodramus bairdii*), have potential to occur in the Brininstool and Red Draw Development Areas and thus the Zion Development Area as well.

In addition, the desktop constraints analysis also noted that the lesser prairie-chicken (LPC) has identified "estimated occupied range" in the Brininstool and Red Draw Development Areas. The LPC is not listed under the Endangered Species Act (ESA) but should be given consideration based on potential for relisting under the ESA and/or conservation agreements.

Since the desktop constraints analysis was conducted in 2016, Arcadis performed a desktop review of USFWS IPaC website and the New Mexico Department of Game protected species lists for Lea County, New Mexico to confirm the identify federal- and state-listed T&E species still have potential to occur in the Zion Development Area and no new species were added since 2016. From review of the USFWS IPaC and Lea County species records, the species identified in the 2016 desktop constraints are still valid, except for the Arctic peregrine falcon, which has since been removed from the list. **Table 3** provides a list of state and federally listed avian T&E species with the potential to occur within Lea County, New Mexico.

ENVIRONMENTAL FIELD SURVEY
ZION DEVELOPMENT AREA

Table 3 Annotated County List of Rare Avian Species in Lea County, New Mexico.

Common Name	Scientific Name	Federal Status	State Status
Birds			
Bald eagle	<i>Haliaeetus leucocephalus</i>		T
Aplomado falcon	<i>Falco femoralis</i>	E	E
Peregrine falcon	<i>Falco peregrinus</i>		T
Least tern	<i>Sternula antillarum</i>	E	E
Broad-billed hummingbird	<i>Cynanthus latirostris</i>		T
Bell's vireo	<i>Vireo bellii</i>		T
Baird's sparrow	<i>Centronyx bairdii</i>		T

Abbreviations:

*E= Endangered, T= Threatened

Arcadis surveyed the Zion Development Area to assess potential habitat for northern aplomado falcon, bell's vireo, baird's sparrow and LPC and document observations of the species or signs of potential presence and resource availability. The PC survey method covered an adequate amount of the Study Area to account for all possible habitat types. No T&E species were observed during the May 13 to 15, 2019 surveys, and potential for any of the listed T&E and LPC species to occur is low, due to habitat type and land use.

4.3 Recommendations

Development in the Study Area may have the potential to result in displacement of listed-species and migratory birds, especially raptors. Raptor nests usually require larger buffers than passerines to prevent disturbance to nest success and can be up to ½ mile for some species. See **Table 4** for species-specific nest buffers.

Table 4 Species-Specific Nest Buffers in Lea County, New Mexico

Species	Seasonal Buffer*	Spatial Buffer
Bald eagle	February 1 – August 15	½ mile
Aplomado falcon	March 1 – August 15	½ mile
Peregrine falcon	March 1 – August 31	½ mile
Swainson's hawk	March 1 – August 15	½ mile
Prairie falcon	April 1 – August 31	½ mile
American kestrel	April 1 – August 15	¼ mile
Ferruginous hawk	March 15 – August 15	½ mile
Northern harrier	April 1 – August 15	½ mile
Red-tailed hawk	March 15 – August 15	½ mile
Great-horned owl	December 1 – August 1	¼ mile
Barn owl	December 1 – August 1	¼ mile
Small Passerines (all other species observed during survey)	While nest is active	200 feet

Notes:

* Dates and buffer sizes are consistent with the Nationwide Standard Conservation Measures (USFWS 2016); the buffer applies to permanent surface occupancy (e.g. major transmission power lines, communication towers, water-treaters); the buffer applies to temporary human disturbance (i.e. routine maintenance, inspections, and construction activities).

ENVIRONMENTAL FIELD SURVEY
ZION DEVELOPMENT AREA

Because of the high volume of nesting raptors observed during the May 2019 surveys, it is recommended to conduct additional raptor nest surveys, along with presence/absence surveys prior to development, as well as take into consideration if construction occurs during migratory bird nesting season.

In lieu of the contrasting federal position on the enforcement of the MBTA, Arcadis recommends a continued, consistent, and pragmatic course of action whereby pre-construction nest surveys are conducted prior to clearing vegetation outside of existing access roads for all work conducted during March 1 to August 31, the migratory bird nesting season.

ENVIRONMENTAL FIELD SURVEY ZION DEVELOPMENT AREA

5 HYDROLOGY

Potential impacts due to the construction and operation of proposed development to surface water resources in the Study Area were evaluated by reviewing the location of these features (ponds, streams, wetlands, etc.) identified during the survey.

5.1 Surface Hydrology

Southwestern Lea County, including the Study Area, lies within the Lower Pecos River Basin And Lower Pecos-Red Bluff Reservoir watershed (hydrologic unit code [HUC] 13070001) (USEPA 2019b). The major stream in this basin is the Pecos River, which is located approximately 30 miles to the west of the Study Area in southeastern Eddy County. Surface water in the Lower Pecos River Basin comes from three main sources: inflow from the Upper Pecos River Basin, flood inflow from storm events, and groundwater base inflow. The Pecos River bisects Eddy County and runs through the center of the City of Carlsbad. The Pecos River is dammed by Brantley Dam and by Avalon Dam 10 miles northwest and five miles north of Carlsbad, respectively, and by Red Bluff Dam located just across the New Mexico – Texas state line.

Surface water within the Study Area is affected naturally by the shallow geology, topography, precipitation, and some water erosion. The area is located in the semi-arid southwest, near the northern edge of the Chihuahuan Desert. The climate is characterized by low annual precipitation, low humidity, and high average annual temperature and ranges from dry subhumid to arid. Precipitation is quite variable both regionally and seasonally and averages about 12 inches or less annually with the greatest rainfall occurring as monsoonal storms during the summer months. The area is situated at the southwest edge of the Great Plains dust-bowl area and is sometimes subjected to severe windstorms (Nicholson and Clebsch 1961).

Anthropogenic activities, such as livestock grazing management and oil and gas development, have generally had little effect on surface flow in the Study Area and adjacent vicinity. Flow appears to trend towards the northeast and is affected most by local topography.

5.1.1 Floodplain

Executive Order 11988 of May 24, 1977 (Floodplain Management) requires Federal agencies to take action to reduce the risk of flood loss; to minimize the impact of floods on human safety, health, and welfare; and to restore and preserve the natural and beneficial values served by floodplains. As defined in Executive Order 11988, floodplains are lowland and relatively flat areas adjoining inland and coastal waters including floodprone areas of offshore islands, including at a minimum, that area subject to a one percent or greater chance of flooding in any given year. Floodwater energy is dissipated as flows spread out over a floodplain, and significant storage of floodwater can occur through infiltration and surficial storage in localized depressions on a floodplain.

The Federal Emergency Management Agency National Flood Hazard Layer indicates the survey area is mapped as Zone D (FEMA 2019). The Zone D designation is used for areas where there are possible but undetermined flood hazards, as no analysis of flood hazards has been conducted. Lea County has a floodplain management department, but no apparent floodplain management ordinances.

ENVIRONMENTAL FIELD SURVEY ZION DEVELOPMENT AREA

5.1.2 Surface Waterbody Features

A waterbody feature is a waters of the United States if there is a direct connection (i.e., nexus) to a Traditional Navigable Waterway (TNW) or Relatively Permanent Waterway (RPW), connection through an abutting wetland, connection due to being located within a floodplain, etc. Lea County is located in FEMA Zone D (possible but undetermined flood hazards, as no analysis of flood hazards has been conducted); therefore, the location of the 100-year floodplain was not used to determine potential jurisdictional status.

Based on the National Hydrography Dataset (NHD) Online Data Mapper, there was one mapped stream within the southeastern edge of the Study Area, as well as one mapped pond within Section 34, but field verification confirmed that neither is present. However, during the May 2019 surveys two ephemeral drainages were identified within the Study Area (**Figure 3**). Because there does not appear to be a surface connection to a TNW or RPW, these drainages appear to be non-jurisdictional waterbody features. The Ordinary High Water Mark data sheets for the ephemeral drainages are attached in **Appendix D**.

5.1.3 Wetland and Riparian Areas

Wetlands are defined as “areas that are inundated or saturated by surface or groundwater at a frequency and duration sufficient to support, and under normal circumstances do support, a prevalence of wetland vegetation typically adapted for life in saturate soil condition” (Environmental Laboratory 1987). Section 404 of the Clean Water Act (CWA) provides the protection of waters of the United States through regulating the discharge of dredged or fill materials. Wetlands occur in spaces between terrestrial and aquatic systems where the water table is usually at or near the surface or the land is covered by shallow water (Cowardin et al. 1979). Wetlands must have one or more of the following three attributes:

- At least periodically, the land supports predominantly hydrophytes;
- The substrate is predominantly undrained hydric soil; and
- The substrate is non-solid, is saturated with water or covered by shallow water at some time during the growing season of each year.

Based on the National Wetlands Inventory (NWI) Online Data Mapper, there are no mapped wetlands or riparian areas within the Study Area nor were there any wetlands observed during May 2019 surveys.

5.2 Findings and Recommendation

There are two ephemeral drainages within the Study Area and immediate vicinity. These features do not appear to be jurisdictional waters of the United States due to a lack of connection to a TNW or RPW and would therefore not require permitting for impacts under Section 404 of the CWA. The USEPA and US Army Corp of Engineers (USACE) have the authority to determine the location and extent of jurisdictional waters of the United States; therefore, this determination should be considered preliminary until their concurrence has been obtained. Although impacts to waterbody features may not require a permit under Section 404 of the CWA, it is still recommended that these drainage features be avoided or impacts mitigated. If the USACE determines that these features are jurisdictional, impacts would likely be verified under the Nationwide Permit Program as long as a proposed project complies with the terms and conditions. If determined to be jurisdictional, impacts to the waterbody features will also require a CWA Section 401 Water Quality Certification (33 USC §1342). The New Mexico Environment Department

ENVIRONMENTAL FIELD SURVEY
ZION DEVELOPMENT AREA

(NMED) is the issuing authority for Water Quality Certifications and has conditionally certified projects that are authorized under the 2017 Nationwide Permit Program as long as the project complies with the conditions of the certification (NMED 2017).

Surface waters of the state of New Mexico are broadly defined and include *surface water situated wholly or partly within or bordering upon the state, including lakes, rivers, streams (including intermittent streams) mudflats, sandflats, wetlands, sloughs, prairie potholes, wet meadows, playa lakes, reservoirs or natural ponds. Surface waters of the state also means all tributaries of such waters, including adjacent wetlands, any manmade bodies of water that were originally created in surface waters of the state or resulted in the impoundment of surface waters of the state, and any "waters of the United States" as defined under the Clean Water Act (New Mexico Administrative Code [NMAC] 20.6.4.7 CCC.)* While NMED Surface Water Quality Bureau does not require a permit for working in a surface water of the state, surface water quality standards under NMAC 20.6.4 *Standards for Interstate and Intrastate Surface Waters* would apply for any work in surface waters of the state. Ephemeral drainages and their associated tributaries are considered surface waters of the state when they have a connection as a tributary to a surface water of the state (e.g. lake, river, stream, intermittent stream). The ephemeral drainages in the Study Area do not appear to be surface waters of the state due to a lack of connection to a surface water of the state (e.g. lake, river, stream, intermittent stream) and would therefore not require compliance with surface water quality standards under NMAC 20.6.4 *Standards for Interstate and Intrastate Surface Waters* for any work in these ephemeral drainages.

Typically, sites that have the potential to discharge sediments into adjacent waterways and waterbodies due to storm water runoff are required to meet storm water control requirements set forth in state and federal National Pollutant Discharge Elimination System (NPDES) regulations. However, the CWA section 402(l)(2) provides that the Environmental Protection Agency shall not require, nor force a state to require, a CWA section 402 permit for discharges of stormwater runoff from oil and gas exploration, production, processing or treatment operations, or transmissions facilities, composed entirely of flows that are from conveyances or systems of conveyances used for collecting and conveying precipitation runoff, and that are not "contaminated by contact with any overburden, raw material, intermediate products, finished product, byproduct or waste products located on the site of such operations." This exemption applies to both construction and industrial activities associated with oil and gas exploration, production, processing or treatment operations, or transmission facilities.¹

The Federal Emergency Management Agency National Flood Hazard Layer indicates the survey area is mapped as Zone D (FEMA 2019). The Zone D designation is used for areas where there are possible but undetermined flood hazards, as no analysis of flood hazards has been conducted. Lea County has a floodplain management department, but no apparent floodplain management ordinances.

¹ <https://www.epa.gov/npdes/oil-and-gas-stormwater-permitting#undefined>

ENVIRONMENTAL FIELD SURVEY
ZION DEVELOPMENT AREA

This page intentionally left blank.

ENVIRONMENTAL FIELD SURVEY
ZION DEVELOPMENT AREA

6 CULTURAL RESOURCES

The Study Area is located at the southwestern edge of the Llano Estacado (“staked plain”), a level, nearly featureless plain with few to no water resources (Holliday 1995). The principal surficial deposit on the Llano Estacado is the Blackwater Draw Formation. The Blackwater Draw Formation is an early to late Pleistocene aeolian deposit and intercalated buried soils. Draws, playas, and salina basins are cut into the Blackwater Draw formation and contain late Pleistocene and Holocene lacustrine, paludal, alluvial and aeolian deposit (Holliday 1995). These deposits are sensitive for cultural resources on the Llano Estacado.

The Zion Development Area is composed of portions of the Brininstool and Red Hills Development Areas. A previous evaluation of the potential for identifying cultural resources through pedestrian survey in South Lea Development Area by Statistical Research Inc. indicated that the higher potential was in the Brininstool Development and the Red Hills Development Area had medium potential for identifying cultural resources (Tetra Tech 2016).

6.1 File Search

The NMCRIS was accessed by professional archaeologist Dulaney Barclay on May 15, 2019. The Study Area was examined for known cultural resources investigations, and archaeological and historical sites. Twelve previous surveys have been conducted within the Study Area (**Table 5**). The majority of the previous surveys are linear surveys for pipelines and seismic lines. The earliest survey was conducted in 1984 and the most recent was conducted in 2018.

Table 5 Previous Cultural Projects in the Study Area

Project #	Project Type	Associated Project Name	Year
2151	Block & Linear	Antelope Ridge Unit Well No. #9 & #10	1984
2218	Pipeline	Texaco Inc.- Red Tanks Project #3765	1985
36783	Seismic	Seismic Testing Line #DB770 (91-29)	1991
50410	Pipeline	Hadson Gas Gathering & Processing Co. Project 873	1995
59795	Pipeline	Kaiser-Francis Oil Co 5 Mile Pipeline	1998
75147	Seismic	Southwest Lea County 3D Seismic Survey	2001
100715	Pipeline	Pipeline to Connect Bold Energy L.P. Antelope Ridge #9 to Existing Pipeline	2006
100865	Pipeline	Pipeline to Connect Bold Energy L.P. Antelope Ridge Unit to Curry Federal No. 2 Well	2006
111105	Block & Linear	Survey for Potash Exploration	2008
129811	Seismic	Delaware 3C 3-D Seismic Project	2014
140515	Pipeline	Unknown	2018
141458	Pipeline	Unknown	2018

Only two archaeological sites have been documented within the Study Area. Areas that should be avoided are shown in **Figure 6**. The sites consist of two historic archaeological sites (LA133413 and LA133270). LA133413 contains a house foundation, windmills and concrete trough. It dates between 1890 and 1935. It

ENVIRONMENTAL FIELD SURVEY ZION DEVELOPMENT AREA

has not been evaluated for National Register of Historic Places eligibility. LA133270 consists of a historic artifact scatter dating between 1846 and 1935. It has not been evaluated for National Register of Historic Places eligibility. While only two historic archaeological sites have been recorded in the Zion Development Area, a large portion of it has relatively high potential for subsurface cultural resources.

A custom soil survey of the Study Area indicates a high percentage of it is covered by soils that could contain undetected cultural materials (Natural Resources Conservation Service [NRCS] 2019). It is estimated that 40.8% of the Study Area is covered by Bernino-Cacique loamy fine sand association; 29% is covered by Bernino-Cacique fine sandy loam association; 21.8% by Simona fine sandy loam 0 to 3 percent slope; 3.5% Ratliff-Wink fine sandy loams; 3.1% Tonuco loamy fine sand 0 to 3 percent slope; and 1.7% Kimbrough gravelly loam 0 to 3 percent slope. The parent material for the Berino loamy sands are aeolian sands that overlie calcareous sandy alluvium. They are well drained and can be up to 80 inches thick. The typical profile consists of 6 inches of a loamy fine sand overlying 60 inches of a sandy clay loam. The parent material for Cacique loamy fine sands are calcareous aeolian sands. They are well drained and are up to 40 inches thick. The typical profile consists of 12 inches of loamy fine sand; 16 inches of a sandy clay loam; and 10 inches of cemented material (petrocalcic material). Berino-Cacique sandy loams are similar to Bernino-Cacique loamy fine and sands but are generally loamier in content. The parent material for Simona fine sandy loam are calcareous aeolian sands. They are well drained and up to 20 inches thick. The typical profile consists of 8 inches of a fine sandy loam overlying 8 inches of a gravelly fine sandy loam. Both units overlie 10 inches of cemented material (petrocalcic material). The parent material for Ratliff fine sandy loams are calcareous alluvium and aeolian deposits. They are well drained and can be up to 80 inches thick. The typical profile consists of 4 inches of a fine sandy loam overlying 56 inches of a clay loam. The parent material for the Wink sandy loam is similar to the Ratliff sandy loam. They are well drained and up to 80 inches thick. The typical profile consists of 12 inches of a fine sandy loam and 48 inches of a sandy loam. The parent material for Tonuco loamy fine sand are aeolian sand deposits. They are excessively drained and up to 20 inches thick. The typical profile consists of 12 inches of a loamy fine sand overlying 5 inches of a loamy sand. Both units overlie cemented material (petrocalcic material). Kimbrough gravelly loams are derived from loamy aeolian deposits. They are well drained and up to 18 inches thick. A typical profile consists of 3 inches of gravelly loam overlying 7 inches of loam. Both units overlie cemented material. The characteristics of the Bernino-Cacique loamy fine sand, Bernino-Cacique fine sandy loam, and the Ratliff-Wink fine sandy loam soil associations are conducive to the preservation of intact cultural materials in the subsurface.

6.2 Recommendations

The two archaeological sites within the Study Area have not been evaluated for National Register of Historic Places eligibility. Therefore, these sites should be treated as potentially eligible for the National Register and avoided during construction. Based on the current evaluation, a large percentage of the Zion Development Area has a high potential for subsurface archaeological materials. It's recommended that if archaeological resources are discovered within the Study Area during construction, work be stopped and the location of the find be protected. The New Mexico SHPO and the appropriate local authorities (for human remains) should be contacted immediately. No work should continue in the vicinity of the resource until all proper protocols for the remains or artifacts have been completed.

Additionally, Section 106 of the National Historic Preservation Act of 1966, as amended, and its implementing regulations contained in 36 CFR 800 requires federal agencies to consider the impacts of federal

ENVIRONMENTAL FIELD SURVEY
ZION DEVELOPMENT AREA

undertakings upon historic properties. Federal undertakings are defined in the regulations as federal actions requiring a federal permit or utilizing federal funding for their implementation. Historic properties are defined in the regulations as cultural resources which are listed in, or are eligible for listing in, the National Register of Historic Places including unidentified properties. Under Section 106 and its implementing regulations, a cultural resources inventory may be required if the project becomes a federal undertaking. Development within the Zion Development Area would become a federal undertaking if the proposed development necessitates the issuance of a Section 404 permit from the USACE under the Clean Water Act or a permit issued by the federal government (e.g. Bureau of Land Management).

ENVIRONMENTAL FIELD SURVEY
ZION DEVELOPMENT AREA

This page intentionally left blank.

ENVIRONMENTAL FIELD SURVEY ZION DEVELOPMENT AREA

7 RECOMMENDATIONS

With careful planning of infrastructure within the Study Area, impacts will be low. Existing roads are located in most of the Study Area with the majority maintained by the county, and existing rights-of-way or corridors occur in a portion of the proposed Study Area. The following provides a summary of the recommendations for the Zion Development Area.

7.1 Vegetation

When reclaiming areas that are not needed for daily operations on sandy soil areas, it is recommended to apply suitable native seed mixtures, such as sand lovegrass or laying down net straw erosion control blankets. Since vegetation is difficult to establish, these areas should be seeded in the fall to take advantage of winter moisture and get a head start on annual weeds. If winter moisture is not available, these areas should be watered prior to spring long enough to establish a good root. Quick revegetation will protect these areas from wind and water erosion and will continue to provide habitat for the species reliant upon them.

7.2 Migratory Birds

There is suitable habitat for nesting migratory birds, including raptors, within the Study Area. It is recommended that all vegetation clearing activities occur outside of the migratory bird nesting season (March 1 – August 31). Otherwise, a breeding season nest survey should be completed two weeks prior to any surface disturbance if work is planned within the nesting season.

7.3 Surface Waterbody Features

If development is proposed within the two ephemeral drainages identified within the Study Area (**Figure 4**), sediment control best management practices, such as silt ponds, are recommended to prevent any construction materials, sediments, trench stockpiles from entering drainages. Additionally, soil stabilization methods such as soil binding are recommended due to the potential for surface flow to cause erosion and loss of soils.

7.4 Cultural Resources

Two historic archaeological sites (LA133270 and LA133413) are located within the Study Area. Both are unevaluated for the National Register of Historic Places. They are therefore managed by the SHPO as sites that are potentially eligible for the National Register of Historic Places. As such, they would need to be avoided by the proposed development.

Alternatively, the sites could be evaluated for National Register of Historic Places eligibility and if they were to be evaluated as not eligible for the National Register, avoidance would not be necessary. Any evaluation of National Register of Historic Places eligibility (eligible or not) would need the concurrence of the SHPO.

ENVIRONMENTAL FIELD SURVEY
ZION DEVELOPMENT AREA

This page intentionally left blank.

ENVIRONMENTAL FIELD SURVEY
ZION DEVELOPMENT AREA

8 REFERENCES

- Cowardin, L.M., V. Carter, F.C. Golet, and E.T. LaRoe. 1979. Classification of Wetlands and Deepwater Habitats of the United States. FWS/OBS-79/31, 131p.
- Environmental Laboratory. 1987. "Corps of Engineers Wetlands Delineation Manual," Technical Report Y-87-1, U.S. Army Engineer Waterways Experiment Station, Vicksburg, MS.
- Federal Emergency Management Agency. 2019. National Flood Hazard Layer. [Web page]. Located at <https://www.fema.gov/national-flood-hazard-layer-nfhl>. Accessed: May 2019.
- Holliday, Vance T. 1995. Late Quaternary Stratigraphy of the Southern High Plains. In, *Ancient Peoples and Landscapes*. Eileen Johnson, editor. Museum of Texas Tech University, Lubbock, Texas.
- Natural Resources Conservation Service (NRCS). 2019. Web Soil Survey. [Web page]. Located at <https://websoilsurvey.sc.egov.usda.gov>. Accessed: May 17, 2019.
- New Mexico Environment Department. 2017. Clean Water Act Section 401 Water Quality Certification. Letter to Allan Steinle, U.S. Army Corps of Engineers. March 1. [Web page]. Located at <https://www.env.nm.gov/swqb/404/2017NWPcert.pdf>. Accessed: March 26, 2019.
- Nicholson, Alexander, Jr., and Clebsch, Alfred, Jr., 1961, Geology and Ground-Water Conditions in Southern Lea County, New Mexico, USGS Groundwater Report 6.
- Tetra Tech, August 29, 2016, Baseline Ecological Assessment-Letter Summary Report Proposed South Lea Development Area, Lea County, New Mexico, Tetra Tech Project #212C-MD-00414.306.
- U.S. Environmental Protection Agency (EPA). 2019a. Ecoregions. [Web page]. Located at <https://www.epa.gov/eco-research/ecoregions>.
- USEPA. 2019b. WATERS GeoViewer. [Web page]. Located at <https://epa.maps.arcgis.com/apps/webappviewer/index.html?id=ada349b90c26496ea52aab66a092593b>. Accessed: May 2019.
- U.S. Fish & Wildlife Service (USFWS). 2016. Nationwide Standard Conservation Measures. [Web page]. Located at <https://www.fws.gov/birds/management/project-assessment-tools-and-guidance/conservationmeasures/nationwide-standard-conservation-measures.php>.

ENVIRONMENTAL FIELD SURVEY
ZION DEVELOPMENT AREA

This page intentionally left blank.





FIGURES

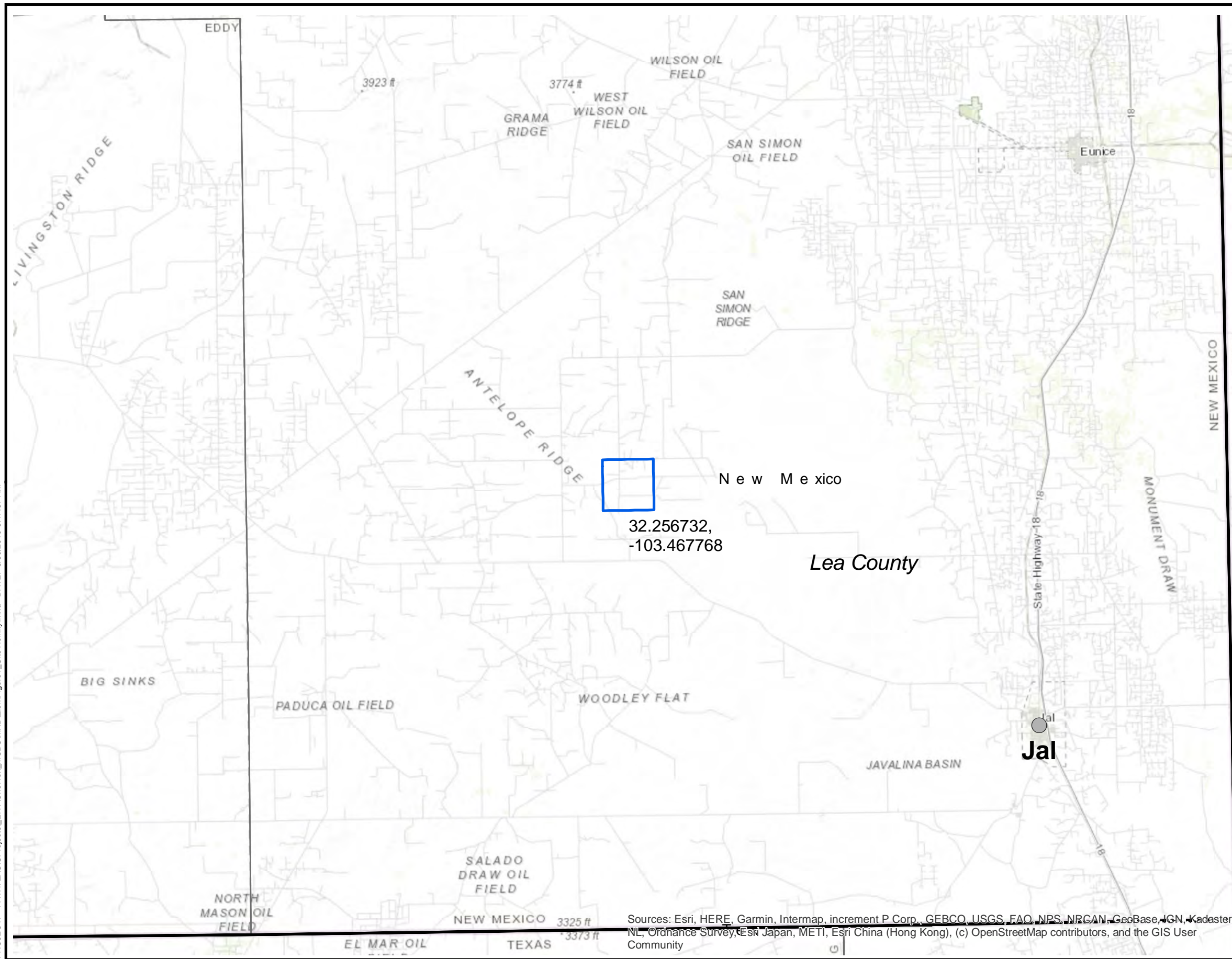

DI\GROUP: ENV\INDV DB: adavis LD: PIC: PM: TM: PROJECT: PATH: Z:\GIS\Projects\ENV\Chevron_MCBUMXD\Zion\Figure1_SiteVicinity.mxd DATE: 5/30/2019 9:47:37 AM



LEGEND

-  Zion Development Area
-  City
-  County Boundary
-  State Boundary

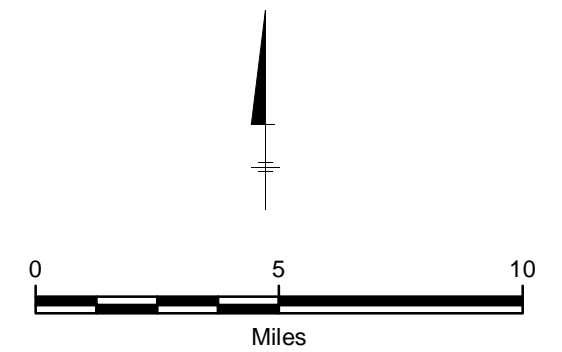

CHEVRON U.S.A. INC.
 BASELINE ECOLOGICAL ASSESSMENT
 ZION DEVELOPMENT AREA
 LEA COUNTY, NEW MEXICO

SITE VICINITY





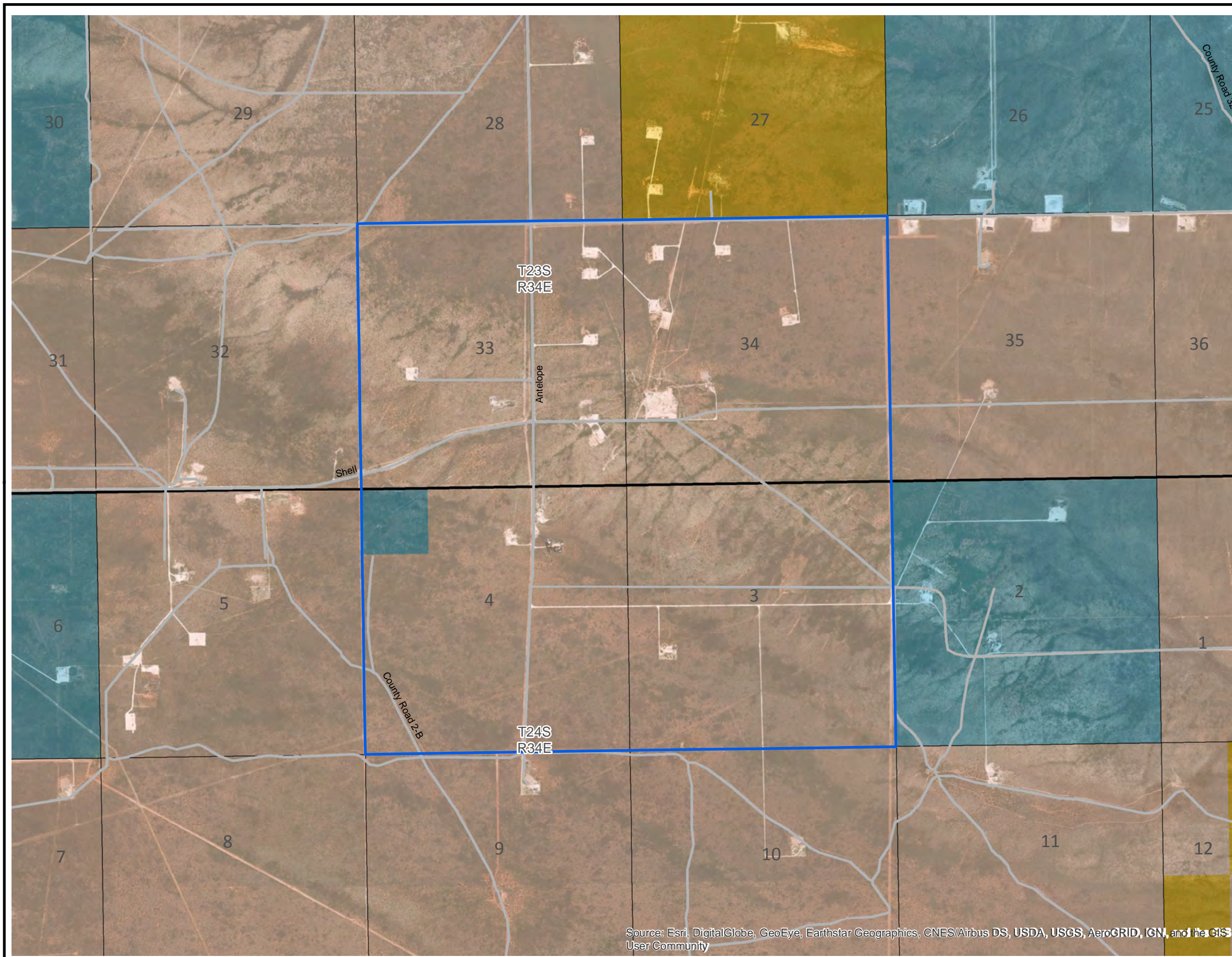

FIGURE
 1



DIV/GROUP: ENV/IMDV DB: adavis LD: PIC: PM: TM:
PROJECT: PATH: Z:\GIS\Projects\ENV\Chevron_MCBUMXD\Zion\Figure2_StudyArea_Aerial.mxd DATE: 5/30/2019 9:41:44 AM



LEGEND

-  Zion Development Area
-  Lea County Roads
-  Townships
-  Sections

SURFACE OWNERSHIP

-  Bureau of Land Management
-  Private
-  State

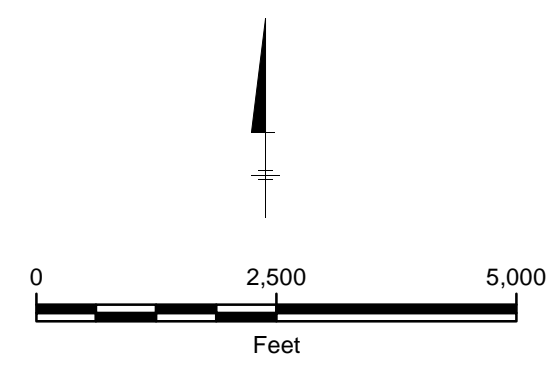

CHEVRON U.S.A. INC.
 BASELINE ECOLOGICAL ASSESSMENT
 ZION DEVELOPMENT AREA
 LEA COUNTY, NEW MEXICO

STUDY AREA – AERIAL VIEW



FIGURE
2

Source: Esri, DigitalGlobe, GeoEye, Earthstar Geographics, CNES/Airbus DS, USDA, USGS, AeroGRID, IGN, and the GIS User Community

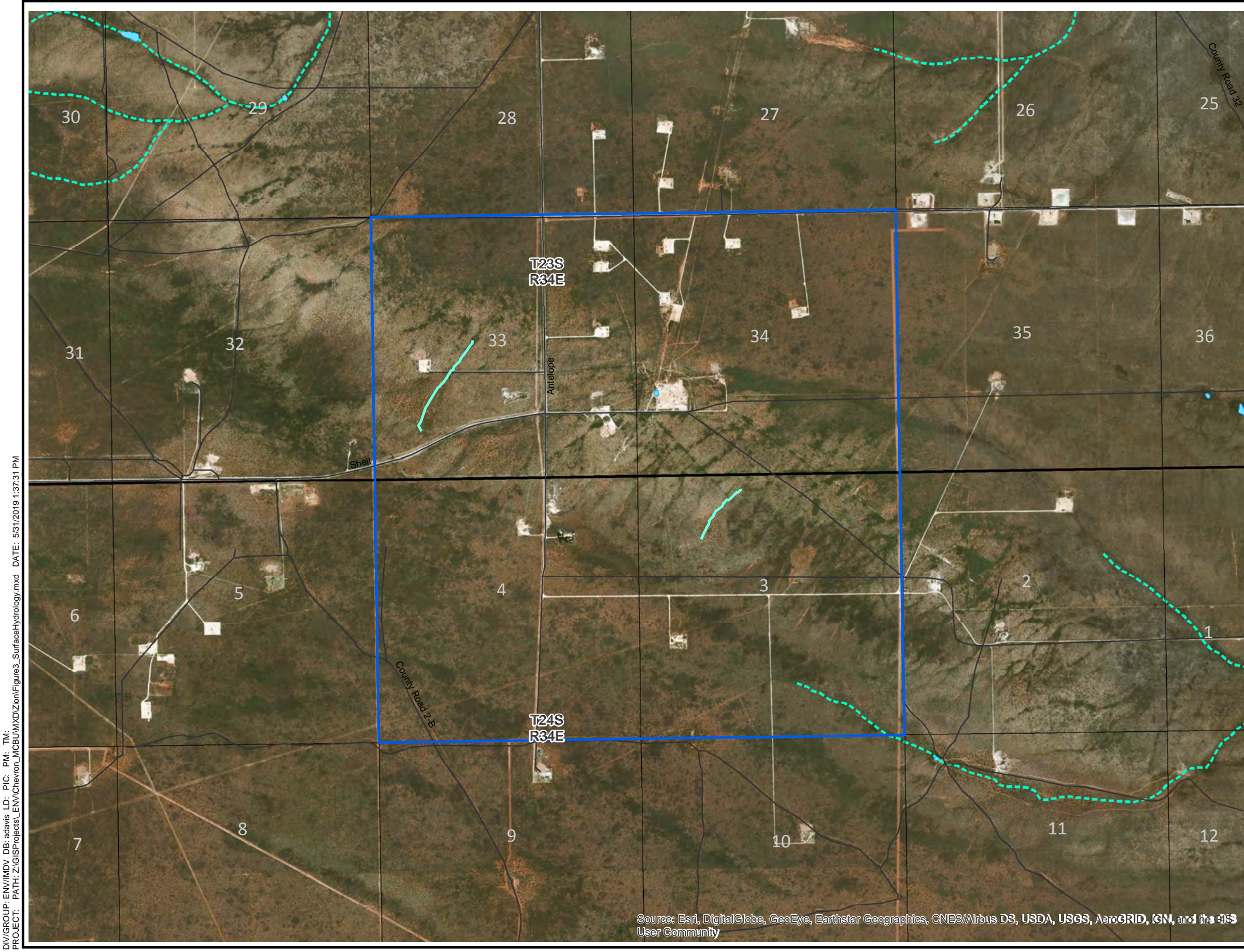

LEGEND

- Zion Development Area
- Lea County Roads
- Townships
- Sections
- Streams (NHD)
- Lake/Pond (NHD)
- Field-Delineated Ephemeral Stream

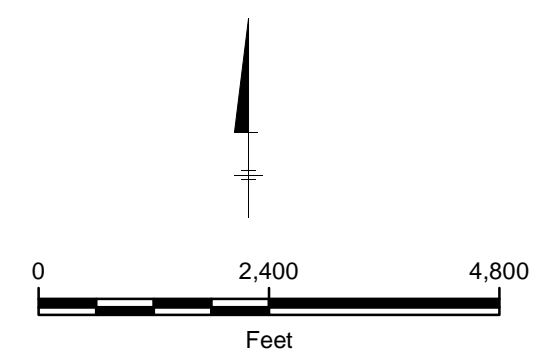

CHEVRON U.S.A. INC.
 BASELINE ECOLOGICAL ASSESSMENT
 ZION DEVELOPMENT AREA
 LEA COUNTY, NEW MEXICO

SURFACE WATER HYDROLOGY

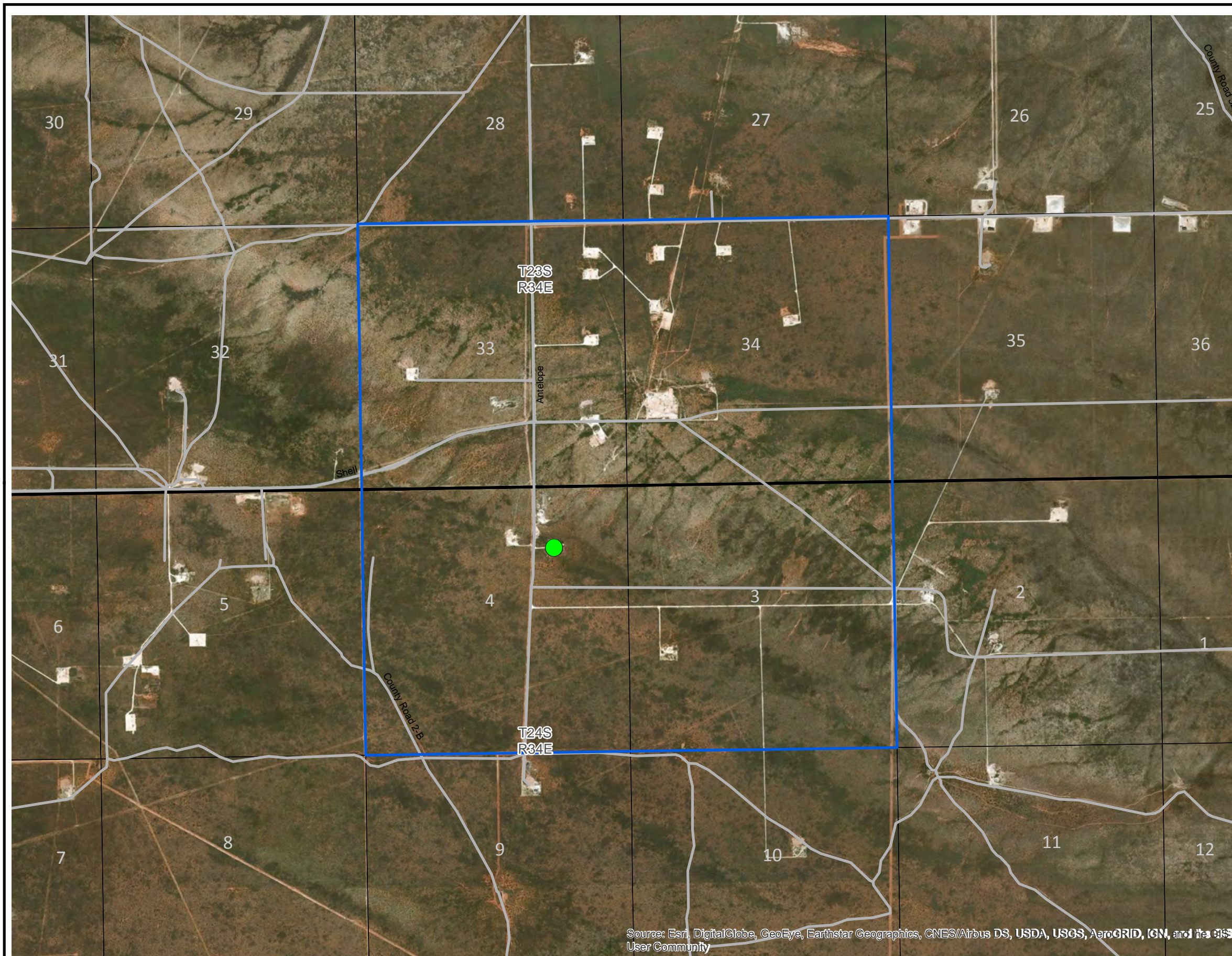

FIGURE
3

Source: Esri, DigitalGlobe, GeoEye, Earthstar Geographics, CNES/Airbus DS, USDA, USGS, AeroGRID, IGN, and the GIS User Community

DIV/GROUP: ENV/IMDV DB: adaws LD: PIC: PM: TM:
 PROJECT: PATH: Z:\GIS\Projects\ENV\Chevron_MCBU\MXD\Zion\Figure3_SurfaceHydrology.mxd DATE: 5/31/2019 1:37:31 PM

DIV/GROUP: EN/IMDV DB: adavis LD: PIC: PM: TM:
PROJECT: PATH: Z:\GIS\Projects\ENV\Chevron_MCBUMXD\Zion\Figure4_PublicReceptors.mxd DATE: 5/30/2019 9:52:03 AM



LEGEND

- Zion Development Area
- Lea County Roads
- Townships
- Sections
- Public Receptors

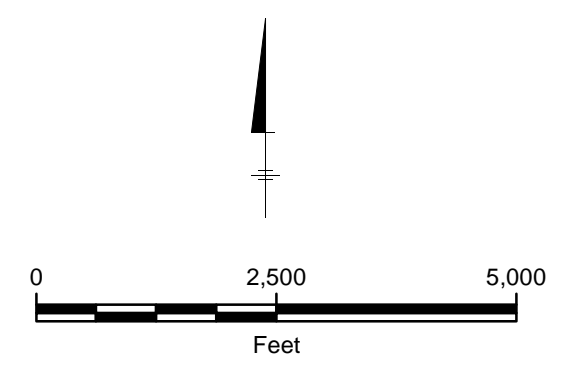

CHEVRON U.S.A. INC.
 BASELINE ECOLOGICAL ASSESSMENT
 ZION DEVELOPMENT AREA
 LEA COUNTY, NEW MEXICO

PUBLIC RECEPTORS



FIGURE
4

Source: Esri, DigitalGlobe, GeoEye, Earthstar Geographics, CNES/Airbus DS, USDA, USGS, AeroGRID, IGN, and the GIS User Community

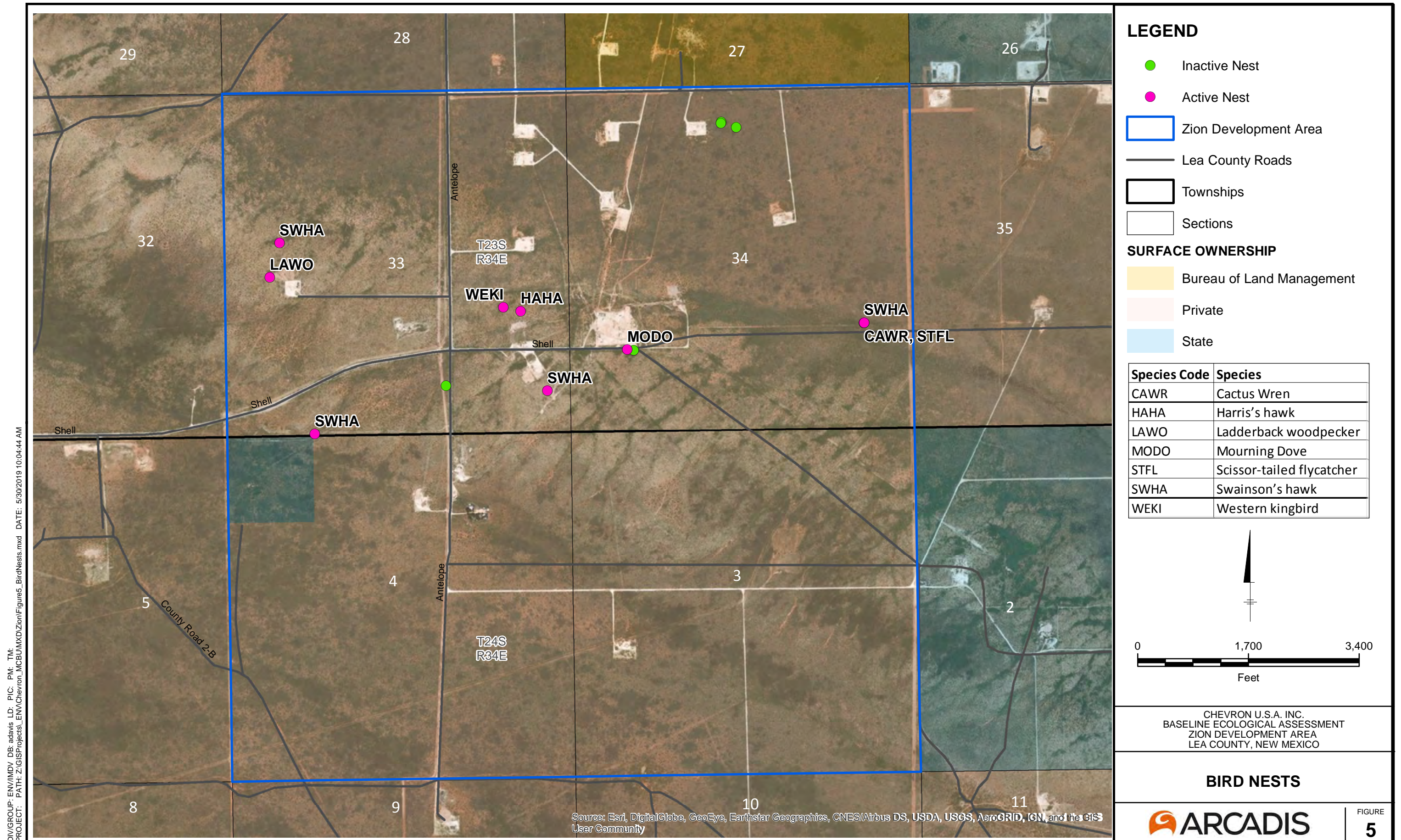





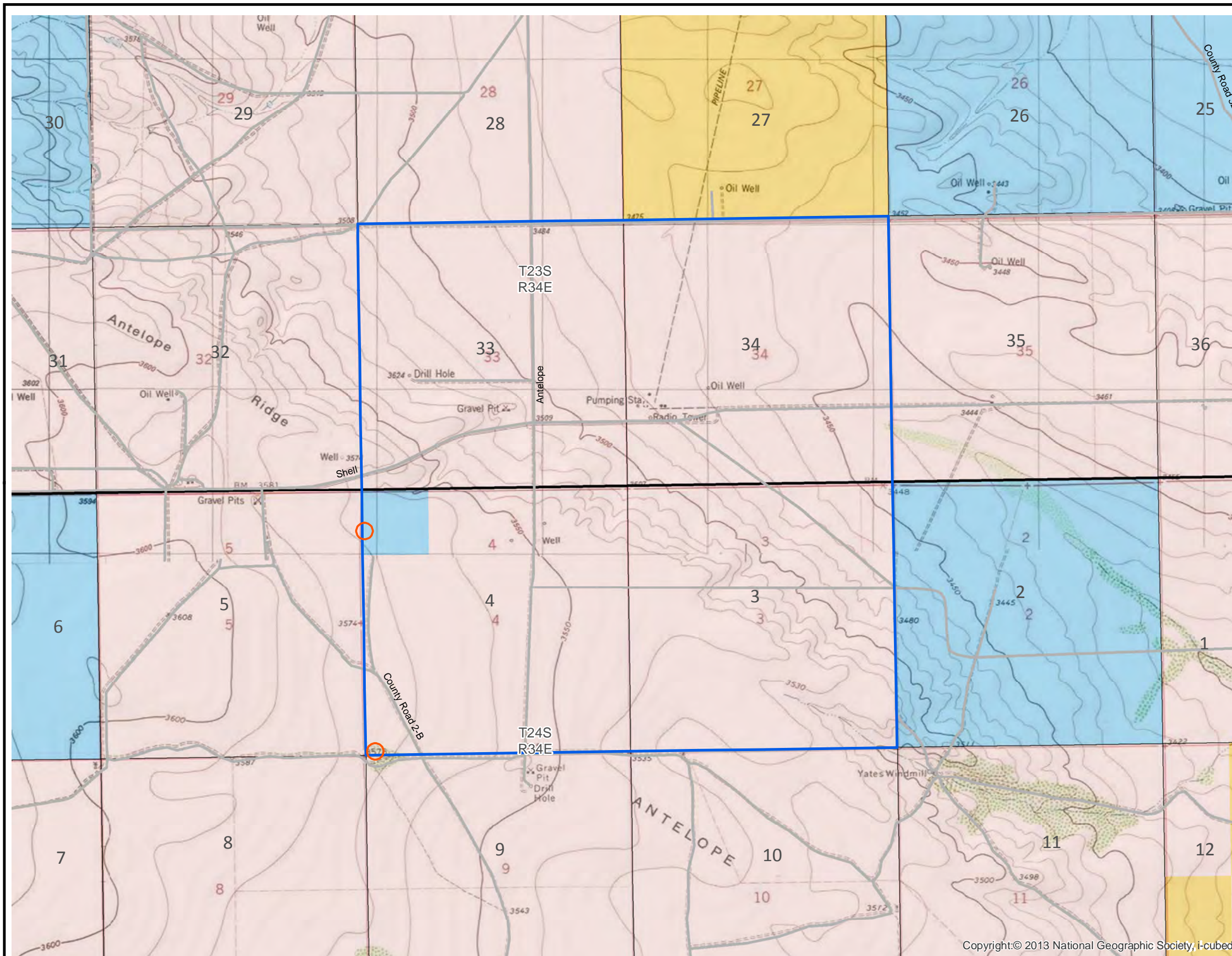



DIV/GROUP: ENV/IMDV DB: adavis LD: PIC: PM: TM: DATE: 5/30/2019 10:04:44 AM
 PROJECT: PATH: Z:\GIS\Projects_Env\Chevron_MCBUMXD\Zion\ZionFigures5_BirdNests.mxd

DIV/GROUP: EN/IMDV DB: adavis LD: PIC: PM: TM:
PROJECT: PATH: Z:\GIS\Projects\EN\Chevron_MCBUMXD\Zion\Figure6_AvoidanceAreas.mxd DATE: 5/30/2019 11:05:08 AM



LEGEND

-  Zion Development Area
-  Lea County Roads
-  Townships
-  Sections
- SURFACE OWNERSHIP**
-  Bureau of Land Management
-  Private
-  State
-  Avoidance Areas

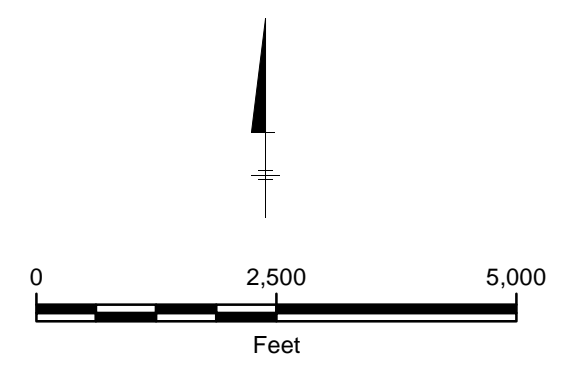

CHEVRON U.S.A. INC.
BASELINE ECOLOGICAL ASSESSMENT
ZION DEVELOPMENT AREA
LEA COUNTY, NEW MEXICO

AVOIDANCE AREAS



FIGURE
6

Copyright:© 2013 National Geographic Society, i-cubed

APPENDIX A

Threatened and Endangered Species of Potential Occurrence in Lea County, New Mexico / BISON-M





Federal or State Threatened/Endangered Species

Lea

<u>Taxonomic Group</u>	<u># Species</u>	<u>Taxonomic Group</u>	<u># Species</u>
Reptiles	1	Birds	7

TOTAL SPECIES: 8

<u>Common Name</u>	<u>Scientific Name</u>	<u>NMGE</u>	<u>USFWS</u>	<u>Critical Habitat</u>	<u>SGCN</u>	<u>Photo</u>
Bald Eagle	Haliaeetus leucocephalus	T			Y	View
Aplomado Falcon	Falco femoralis	E	E		Y	View
Peregrine Falcon	Falco peregrinus	T			Y	View
Least Tern	Sterna antillarum	E	E		Y	View
Broad-billed Hummingbird	Cynanthus latirostris	T			Y	View
Bell's Vireo	Vireo bellii	T			Y	View
Baird's Sparrow	Centronyx bairdii	T			Y	View
Dunes Sagebrush Lizard	Sceloporus arenicolus	E			Y	View

APPENDIX B

USFWS Official Letter for Threatened and Endangered Species of
Potential Occurrence in the Study Area





United States Department of the Interior



FISH AND WILDLIFE SERVICE
New Mexico Ecological Services Field Office
2105 Osuna Road Ne
Albuquerque, NM 87113-1001
Phone: (505) 346-2525 Fax: (505) 346-2542
<http://www.fws.gov/southwest/es/NewMexico/>
http://www.fws.gov/southwest/es/ES_Lists_Main2.html

In Reply Refer To:

May 28, 2019

Consultation Code: 02ENNM00-2019-SLI-0924

Event Code: 02ENNM00-2019-E-01951

Project Name: Zion Development Area

Subject: List of threatened and endangered species that may occur in your proposed project location, and/or may be affected by your proposed project

To Whom It May Concern:

Thank you for your recent request for information on federally listed species and important wildlife habitats that may occur in your project area. The U.S. Fish and Wildlife Service (Service) has responsibility for certain species of New Mexico wildlife under the Endangered Species Act (ESA) of 1973 as amended (16 USC 1531 et seq.), the Migratory Bird Treaty Act (MBTA) as amended (16 USC 701-715), and the Bald and Golden Eagle Protection Act (BGEPA) as amended (16 USC 668-668c). We are providing the following guidance to assist you in determining which federally imperiled species may or may not occur within your project area and to recommend some conservation measures that can be included in your project design.

FEDERALLY-LISTED SPECIES AND DESIGNATED CRITICAL HABITAT

Attached is a list of endangered, threatened, and proposed species that may occur in your project area. Your project area may not necessarily include all or any of these species. Under the ESA, it is the responsibility of the Federal action agency or its designated representative to determine if a proposed action "may affect" endangered, threatened, or proposed species, or designated critical habitat, and if so, to consult with the Service further. Similarly, it is the responsibility of the Federal action agency or project proponent, not the Service, to make "no effect" determinations. If you determine that your proposed action will have "no effect" on threatened or endangered species or their respective critical habitat, you do not need to seek concurrence with the Service. Nevertheless, it is a violation of Federal law to harm or harass any federally-listed threatened or endangered fish or wildlife species without the appropriate permit.

05/28/2019

Event Code: 02ENNM00-2019-E-01951

2

If you determine that your proposed action may affect federally-listed species, consultation with the Service will be necessary. Through the consultation process, we will analyze information contained in a biological assessment that you provide. If your proposed action is associated with Federal funding or permitting, consultation will occur with the Federal agency under section 7(a)(2) of the ESA. Otherwise, an incidental take permit pursuant to section 10(a)(1)(B) of the ESA (also known as a habitat conservation plan) is necessary to harm or harass federally listed threatened or endangered fish or wildlife species. In either case, there is no mechanism for authorizing incidental take "after-the-fact." For more information regarding formal consultation and HCPs, please see the Service's Consultation Handbook and Habitat Conservation Plans at www.fws.gov/endangered/esa-library/index.html#consultations.

The scope of federally listed species compliance not only includes direct effects, but also any interrelated or interdependent project activities (e.g., equipment staging areas, offsite borrow material areas, or utility relocations) and any indirect or cumulative effects that may occur in the action area. The action area includes all areas to be affected, not merely the immediate area involved in the action. Large projects may have effects outside the immediate area to species not listed here that should be addressed. If your action area has suitable habitat for any of the attached species, we recommend that species-specific surveys be conducted during the flowering season for plants and at the appropriate time for wildlife to evaluate any possible project-related impacts.

Candidate Species and Other Sensitive Species

A list of candidate and other sensitive species in your area is also attached. Candidate species and other sensitive species are species that have no legal protection under the ESA, although we recommend that candidate and other sensitive species be included in your surveys and considered for planning purposes. The Service monitors the status of these species. If significant declines occur, these species could potentially be listed. Therefore, actions that may contribute to their decline should be avoided.

Lists of sensitive species including State-listed endangered and threatened species are compiled by New Mexico state agencies. These lists, along with species information, can be found at the following websites:

Biota Information System of New Mexico (BISON-M): www.bison-m.org

New Mexico State Forestry. The New Mexico Endangered Plant Program:
www.emnrd.state.nm.us/SFD/ForestMgt/Endangered.html

New Mexico Rare Plant Technical Council, New Mexico Rare Plants: nmrareplants.unm.edu

Natural Heritage New Mexico, online species database: nhnm.unm.edu

WETLANDS AND FLOODPLAINS

05/28/2019

Event Code: 02ENNM00-2019-E-01951

3

Under Executive Orders 11988 and 11990, Federal agencies are required to minimize the destruction, loss, or degradation of wetlands and floodplains, and preserve and enhance their natural and beneficial values. These habitats should be conserved through avoidance, or mitigated to ensure that there would be no net loss of wetlands function and value.

We encourage you to use the National Wetland Inventory (NWI) maps in conjunction with ground-truthing to identify wetlands occurring in your project area. The Service's NWI program website, www.fws.gov/wetlands/Data/Mapper.html integrates digital map data with other resource information. We also recommend you contact the U.S. Army Corps of Engineers for permitting requirements under section 404 of the Clean Water Act if your proposed action could impact floodplains or wetlands.

MIGRATORY BIRDS

The MBTA prohibits the taking of migratory birds, nests, and eggs, except as permitted by the Service's Migratory Bird Office. To minimize the likelihood of adverse impacts to migratory birds, we recommend construction activities occur outside the general bird nesting season from March through August, or that areas proposed for construction during the nesting season be surveyed, and when occupied, avoided until the young have fledged.

We recommend review of Birds of Conservation Concern at website www.fws.gov/migratorybirds/CurrentBirdIssues/Management/BCC.html to fully evaluate the effects to the birds at your site. This list identifies birds that are potentially threatened by disturbance and construction.

BALD AND GOLDEN EAGLES

The bald eagle (*Haliaeetus leucocephalus*) was delisted under the ESA on August 9, 2007. Both the bald eagle and golden eagle (*Aquila chrysaetos*) are still protected under the MBTA and BGEPA. The BGEPA affords both eagles protection in addition to that provided by the MBTA, in particular, by making it unlawful to "disturb" eagles. Under the BGEPA, the Service may issue limited permits to incidentally "take" eagles (e.g., injury, interfering with normal breeding, feeding, or sheltering behavior nest abandonment). For information on bald and golden eagle management guidelines, we recommend you review information provided at www.fws.gov/midwest/eagle/guidelines/bgepa.html.

On our web site www.fws.gov/southwest/es/NewMexico/SBC_intro.cfm, we have included conservation measures that can minimize impacts to federally listed and other sensitive species. These include measures for communication towers, power line safety for raptors, road and highway improvements, spring developments and livestock watering facilities, wastewater facilities, and trenching operations.

We also suggest you contact the New Mexico Department of Game and Fish, and the New Mexico Energy, Minerals, and Natural Resources Department, Forestry Division for information regarding State fish, wildlife, and plants.

05/28/2019

Event Code: 02ENNM00-2019-E-01951

4

Thank you for your concern for endangered and threatened species and New Mexico's wildlife habitats. We appreciate your efforts to identify and avoid impacts to listed and sensitive species in your project area. For further consultation on your proposed activity, please call 505-346-2525 or email nmesfo@fws.gov and reference your Service Consultation Tracking Number.

Attachment(s):

- Official Species List
- Migratory Birds

05/28/2019

Event Code: 02ENNM00-2019-E-01951

1

Official Species List

This list is provided pursuant to Section 7 of the Endangered Species Act, and fulfills the requirement for Federal agencies to "request of the Secretary of the Interior information whether any species which is listed or proposed to be listed may be present in the area of a proposed action".

This species list is provided by:

New Mexico Ecological Services Field Office

2105 Osuna Road Ne

Albuquerque, NM 87113-1001

(505) 346-2525

05/28/2019

Event Code: 02ENNM00-2019-E-01951

2

Project Summary

Consultation Code: 02ENNM00-2019-SLI-0924

Event Code: 02ENNM00-2019-E-01951

Project Name: Zion Development Area

Project Type: OIL OR GAS

Project Description: Client is scoping out area for potential development. Timing undetermined.

Project Location:

Approximate location of the project can be viewed in Google Maps: <https://www.google.com/maps/place/32.245906569322784N103.4637874526238W>

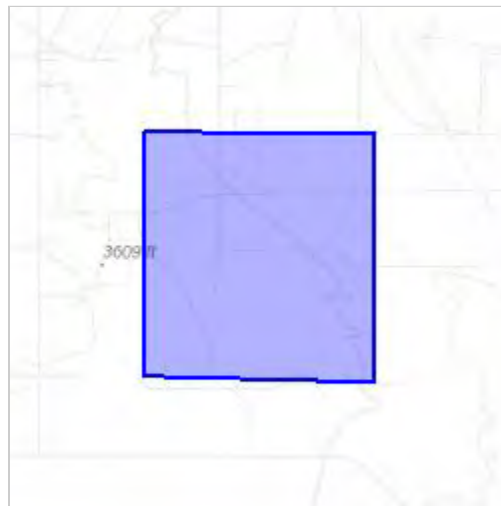

Counties: Lea, NM

05/28/2019

Event Code: 02ENNM00-2019-E-01951

3

Endangered Species Act Species

There is a total of 1 threatened, endangered, or candidate species on this species list.

Species on this list should be considered in an effects analysis for your project and could include species that exist in another geographic area. For example, certain fish may appear on the species list because a project could affect downstream species.

IPaC does not display listed species or critical habitats under the sole jurisdiction of NOAA Fisheries¹, as USFWS does not have the authority to speak on behalf of NOAA and the Department of Commerce.

See the "Critical habitats" section below for those critical habitats that lie wholly or partially within your project area under this office's jurisdiction. Please contact the designated FWS office if you have questions.

-
1. [NOAA Fisheries](#), also known as the National Marine Fisheries Service (NMFS), is an office of the National Oceanic and Atmospheric Administration within the Department of Commerce.

Birds

NAME	STATUS
Northern Aplomado Falcon <i>Falco femoralis septentrionalis</i> Population: U.S.A (AZ, NM) No critical habitat has been designated for this species. Species profile: https://ecos.fws.gov/ecp/species/1923	Experimental Population, Non- Essential

Critical habitats

THERE ARE NO CRITICAL HABITATS WITHIN YOUR PROJECT AREA UNDER THIS OFFICE'S JURISDICTION.

05/28/2019

Event Code: 02ENNM00-2019-E-01951

1

Migratory Birds

Certain birds are protected under the Migratory Bird Treaty Act¹ and the Bald and Golden Eagle Protection Act².

Any person or organization who plans or conducts activities that may result in impacts to migratory birds, eagles, and their habitats should follow appropriate regulations and consider implementing appropriate conservation measures, as described [below](#).

-
1. The [Migratory Birds Treaty Act](#) of 1918.
 2. The [Bald and Golden Eagle Protection Act](#) of 1940.
 3. 50 C.F.R. Sec. 10.12 and 16 U.S.C. Sec. 668(a)

THERE ARE NO FWS MIGRATORY BIRDS OF CONCERN WITHIN THE VICINITY OF YOUR PROJECT AREA.

Migratory Birds FAQ

Tell me more about conservation measures I can implement to avoid or minimize impacts to migratory birds.

[Nationwide Conservation Measures](#) describes measures that can help avoid and minimize impacts to all birds at any location year round. Implementation of these measures is particularly important when birds are most likely to occur in the project area. When birds may be breeding in the area, identifying the locations of any active nests and avoiding their destruction is a very helpful impact minimization measure. To see when birds are most likely to occur and be breeding in your project area, view the Probability of Presence Summary. [Additional measures](#) and/or [permits](#) may be advisable depending on the type of activity you are conducting and the type of infrastructure or bird species present on your project site.

What does IPaC use to generate the migratory birds potentially occurring in my specified location?

The Migratory Bird Resource List is comprised of USFWS [Birds of Conservation Concern \(BCC\)](#) and other species that may warrant special attention in your project location.

The migratory bird list generated for your project is derived from data provided by the [Avian Knowledge Network \(AKN\)](#). The AKN data is based on a growing collection of [survey, banding, and citizen science datasets](#) and is queried and filtered to return a list of those birds reported as occurring in the 10km grid cell(s) which your project intersects, and that have been identified as warranting special attention because they are a BCC species in that area, an eagle ([Eagle Act](#) requirements may apply), or a species that has a particular vulnerability to offshore activities or development.

05/28/2019

Event Code: 02ENNM00-2019-E-01951

2

Again, the Migratory Bird Resource list includes only a subset of birds that may occur in your project area. It is not representative of all birds that may occur in your project area. To get a list of all birds potentially present in your project area, please visit the [AKN Phenology Tool](#).

What does IPaC use to generate the probability of presence graphs for the migratory birds potentially occurring in my specified location?

The probability of presence graphs associated with your migratory bird list are based on data provided by the [Avian Knowledge Network \(AKN\)](#). This data is derived from a growing collection of [survey, banding, and citizen science datasets](#).

Probability of presence data is continuously being updated as new and better information becomes available. To learn more about how the probability of presence graphs are produced and how to interpret them, go to the Probability of Presence Summary and then click on the "Tell me about these graphs" link.

How do I know if a bird is breeding, wintering, migrating or present year-round in my project area?

To see what part of a particular bird's range your project area falls within (i.e. breeding, wintering, migrating or year-round), you may refer to the following resources: [The Cornell Lab of Ornithology All About Birds Bird Guide](#), or (if you are unsuccessful in locating the bird of interest there), the [Cornell Lab of Ornithology Neotropical Birds guide](#). If a bird on your migratory bird species list has a breeding season associated with it, if that bird does occur in your project area, there may be nests present at some point within the timeframe specified. If "Breeds elsewhere" is indicated, then the bird likely does not breed in your project area.

What are the levels of concern for migratory birds?

Migratory birds delivered through IPaC fall into the following distinct categories of concern:

1. "BCC Rangewide" birds are [Birds of Conservation Concern](#) (BCC) that are of concern throughout their range anywhere within the USA (including Hawaii, the Pacific Islands, Puerto Rico, and the Virgin Islands);
2. "BCC - BCR" birds are BCCs that are of concern only in particular Bird Conservation Regions (BCRs) in the continental USA; and
3. "Non-BCC - Vulnerable" birds are not BCC species in your project area, but appear on your list either because of the [Eagle Act](#) requirements (for eagles) or (for non-eagles) potential susceptibilities in offshore areas from certain types of development or activities (e.g. offshore energy development or longline fishing).

Although it is important to try to avoid and minimize impacts to all birds, efforts should be made, in particular, to avoid and minimize impacts to the birds on this list, especially eagles and BCC species of rangewide concern. For more information on conservation measures you can implement to help avoid and minimize migratory bird impacts and requirements for eagles, please see the FAQs for these topics.

Details about birds that are potentially affected by offshore projects

05/28/2019

Event Code: 02ENNM00-2019-E-01951

3

For additional details about the relative occurrence and abundance of both individual bird species and groups of bird species within your project area off the Atlantic Coast, please visit the [Northeast Ocean Data Portal](#). The Portal also offers data and information about other taxa besides birds that may be helpful to you in your project review. Alternately, you may download the bird model results files underlying the portal maps through the [NOAA NCCOS Integrative Statistical Modeling and Predictive Mapping of Marine Bird Distributions and Abundance on the Atlantic Outer Continental Shelf](#) project webpage.

Bird tracking data can also provide additional details about occurrence and habitat use throughout the year, including migration. Models relying on survey data may not include this information. For additional information on marine bird tracking data, see the [Diving Bird Study](#) and the [nanotag studies](#) or contact [Caleb Spiegel](#) or [Pam Loring](#).

What if I have eagles on my list?

If your project has the potential to disturb or kill eagles, you may need to [obtain a permit](#) to avoid violating the Eagle Act should such impacts occur.

Proper Interpretation and Use of Your Migratory Bird Report

The migratory bird list generated is not a list of all birds in your project area, only a subset of birds of priority concern. To learn more about how your list is generated, and see options for identifying what other birds may be in your project area, please see the FAQ “What does IPaC use to generate the migratory birds potentially occurring in my specified location”. Please be aware this report provides the “probability of presence” of birds within the 10 km grid cell(s) that overlap your project; not your exact project footprint. On the graphs provided, please also look carefully at the survey effort (indicated by the black vertical bar) and for the existence of the “no data” indicator (a red horizontal bar). A high survey effort is the key component. If the survey effort is high, then the probability of presence score can be viewed as more dependable. In contrast, a low survey effort bar or no data bar means a lack of data and, therefore, a lack of certainty about presence of the species. This list is not perfect; it is simply a starting point for identifying what birds of concern have the potential to be in your project area, when they might be there, and if they might be breeding (which means nests might be present). The list helps you know what to look for to confirm presence, and helps guide you in knowing when to implement conservation measures to avoid or minimize potential impacts from your project activities, should presence be confirmed. To learn more about conservation measures, visit the FAQ “Tell me about conservation measures I can implement to avoid or minimize impacts to migratory birds” at the bottom of your migratory bird trust resources page.

APPENDIX C

Photographs



Project Photographs

Chevron – Zion Development Area
Lea County, New Mexico



Photo: 1

Date: 5/16/2019

Description:

Active Swainson's hawk observed during PC surveys within Section 33 of the Study Area. Located in a mesquite tree.

Location:

Section 33 of Study Area



Photo: 2

Date: 5/16/2019

Description:

Three eggs observed in Swainson's hawk's nest.

Location:

Section 33 of Study Area

Project Photographs

Chevron – Zion Development Area
Lea County, New Mexico



Photo: 3

Date: 5/16/2019

Description:

Active Harris's hawk nest on telephone pole.

Location:

Section 34 of Study Area

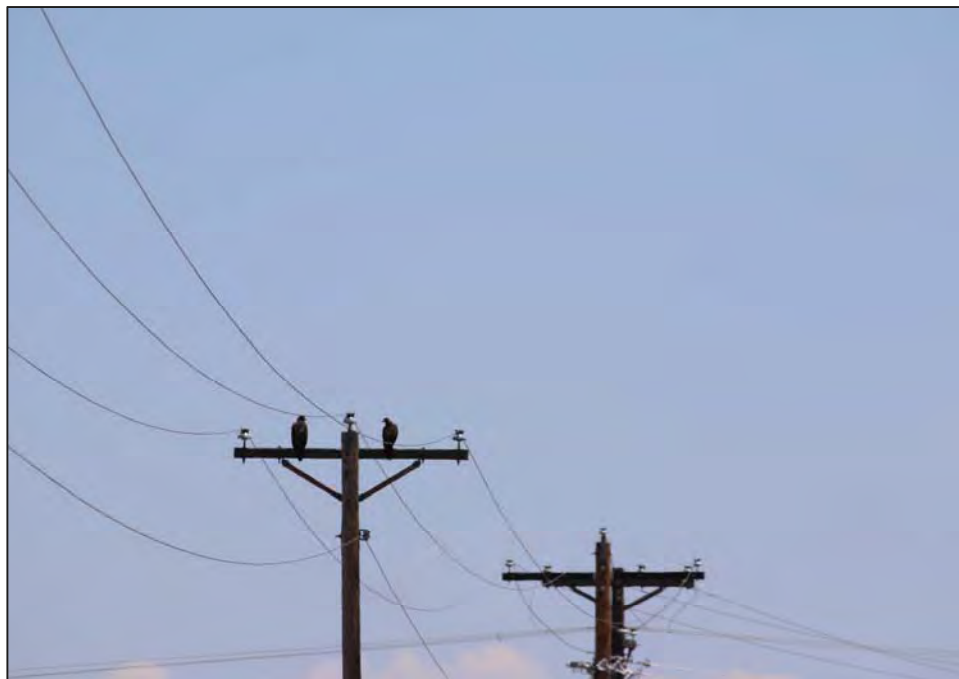

Photo: 4

Date: 5/16/2019

Description:

Mating pair of Harris's hawks near nest.

Location:

Section 34 of Study Area

Project Photographs

Chevron – Zion Development Area
Lea County, New Mexico



Photo: 5

Date: 5/17/2019

Description:

Two adults and one juvenile Swainson's hawk observed in southeastern corner of Study Area.

Location:

Section 3 of Study Area



Photo: 6

Date: 5/16/2019

Description:

Representation of vegetation cover in Section 33. Dominated by honey mesquite and broom, with sparse soap tree yucca. 35% bare ground.

Location:

Section 33 of Study Area

Project Photographs

Chevron – Zion Development Area
Lea County, New Mexico



Photo: 7

Date: 5/16/2019

Description:

Representation of vegetation cover in Section 34. Dominated by honey mesquite and broom, and grama grass sp. 30% bare ground.

Location:

Section 33 of Study Area



Photo: 8

Date: 5/17/2019

Description:

Representation of vegetation cover in Section 4. Dominated by honey mesquite and broom, and grama grass sp. 20 % bare ground.

Location:

Section 4 of Study Area

Project Photographs

Chevron – Zion Development Area
Lea County, New Mexico



Photo: 9

Date: 5/16/2019

Description:

Representation of vegetation cover in Section 3. Dominated by honey mesquite and broom, and grama grass sp. 10% bare ground.

Location:

Section 3 of Study Area



Photo: 10

Date: 5/17/2019

Description:

Active mourning dove nest found in southwestern corner of Section 34 on a low-lying branch of a honey mesquite tree.

Location:

Section 34 of Study Area

Project Photographs

Chevron – Zion Development Area
Lea County, New Mexico



Photo: 11

Date: 5/16/2019

Description:

Three active nests found in same mesquite tree:
Swainson’s hawk, scissor-tailed flycatcher and cactus wren.

Location:

Section 34 of Study Area



Photo: 12

Date: 5/17/2019

Description:

Downstream view of S001;
ephemeral stream

Location:

Section 33 of Study Area

Project Photographs

Chevron – Zion Development Area
Lea County, New Mexico



Photo: 13

Date: 5/16/2019

Description:

Downstream view of S002;
ephemeral stream.

Location:

Section 34 of Study Area

APPENDIX D

Completed Arid West Ephemeral and Intermittent OHWM Data



Wentworth Size Classes

Inches (in)	Millimeters (mm)	Wentworth size class
10.08	256	Boulder
2.56	64	Cobble
0.157	4	Pebble
		Granule
0.079	2.00	Very coarse sand
0.039	1.00	Coarse sand
0.020	0.50	Medium sand
1/2 0.0098	0.25	Fine sand
1/4 0.005	0.125	Very fine sand
1/8 0.0025	0.0625	
1/16 0.0012	0.031	Coarse silt
1/32 0.00061	0.0156	Medium silt
1/64 0.00031	0.0078	Fine silt
1/128 0.00015	0.0039	Very fine silt
		Clay

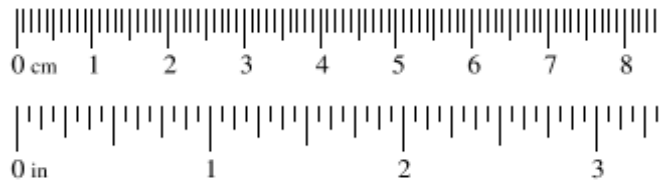

Project ID: _____ Cross section ID: _____ Date: _____ Time: _____

Cross section drawing:

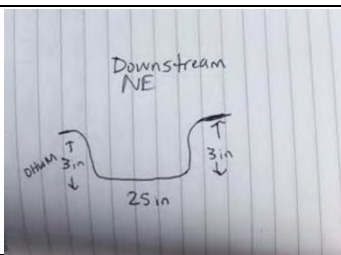

OHWM

GPS point: _____

Indicators:

- Change in average sediment texture
- Change in vegetation species
- Change in vegetation cover
- Break in bank slope
- Other: _____
- Other: _____

Comments:

Floodplain unit:

- Low-Flow Channel
- Active Floodplain
- Low Terrace

GPS point: _____

Characteristics of the floodplain unit:

Average sediment texture: Fine sand

Total veg cover: 0 % Tree: 0 % Shrub 0 % Herb: 0 %

Community successional stage:

- NA
- Early (herbaceous & seedlings)
- Mid (herbaceous, shrubs, saplings)
- Late (herbaceous, shrubs, mature trees)

Indicators:

- Mudcracks
- Ripples
- Drift and/or debris
- Presence of bed and bank
- Benches
- Soil development
- Surface relief
- Other: _____
- Other: _____
- Other: _____

Comments:

Arid West Ephemeral and Intermittent Streams OHWM Datasheet

Project: Zion Development Area Project Number: B0048914.0000 Stream: S002 Investigator(s): Elizabeth Hingle	Date: 5/15/2019 Town: Jal Photo begin file#: —	Time: 13:18 State: New Mexico Photo end file#: —
--	---	---

Y <input checked="" type="checkbox"/> / N <input type="checkbox"/> Do normal circumstances exist on the site? Y <input type="checkbox"/> / N <input checked="" type="checkbox"/> Is the site significantly disturbed?	Location Details: West of Jal, NM Projection: Datum: Coordinates: -103.478264 32.260216
--	---

Potential anthropogenic influences on the channel system: None

Brief site description:

Checklist of resources (if available):

<input checked="" type="checkbox"/> Aerial photography Dates: <input type="checkbox"/> Topographic <input type="checkbox"/> maps Geologic <input type="checkbox"/> maps Vegetation <input type="checkbox"/> maps Soils maps <input type="checkbox"/> Rainfall/precipitation maps <input type="checkbox"/> Existing delineation(s) for site <input checked="" type="checkbox"/> Global positioning system (GPS) <input type="checkbox"/> Other studies	<input type="checkbox"/> Stream gage data Gage number: Period of record: <input type="checkbox"/> History of recent effective discharges <input type="checkbox"/> Results of flood frequency analysis <input type="checkbox"/> Most recent shift-adjusted rating <input type="checkbox"/> Gage heights for 2-, 5-, 10-, and 25-year events and the most recent event exceeding a 5-year event
--	---

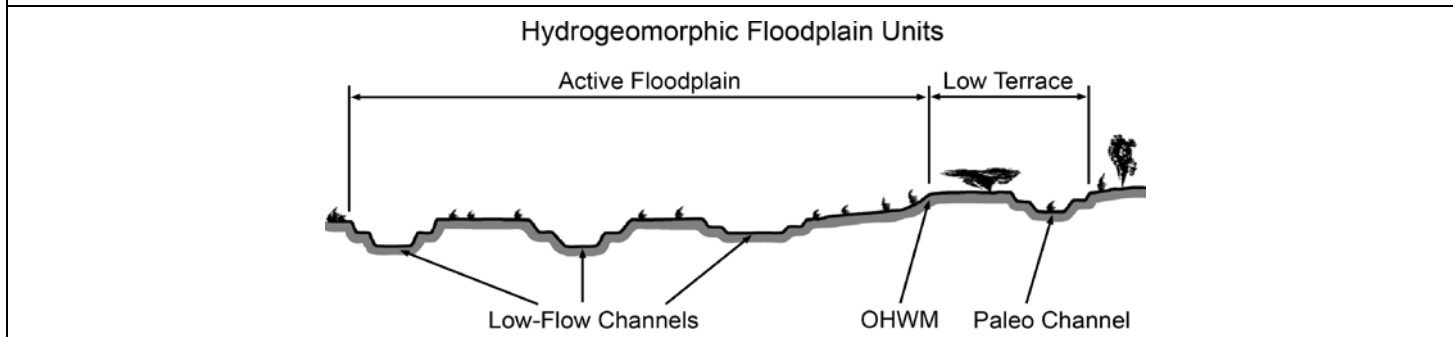

Procedure for identifying and characterizing the floodplain units to assist in identifying the OHWM:

1. Walk the channel and floodplain within the study area to get an impression of the geomorphology and vegetation present at the site.
2. Select a representative cross section across the channel. Draw the cross section and label the floodplain units.
3. Determine a point on the cross section that is characteristic of one of the hydrogeomorphic floodplain units.
 - a) Record the floodplain unit and GPS position.
 - b) Describe the sediment texture (using the Wentworth class size) and the vegetation characteristics of the floodplain unit.
 - c) Identify any indicators present at the location.
4. Repeat for other points in different hydrogeomorphic floodplain units across the cross section.
5. Identify the OHWM and record the indicators. Record the OHWM position via:

<input type="checkbox"/> Mapping on aerial photograph	<input checked="" type="checkbox"/> GPS
<input type="checkbox"/> Digitized on computer	<input type="checkbox"/> Other:

Wentworth Size Classes

Inches (in)	Millimeters (mm)	Wentworth size class
10.08	256	Boulder
2.56	64	Cobble
0.157	4	Pebble
		Granule
0.079	2.00	Very coarse sand
0.039	1.00	Coarse sand
0.020	0.50	Medium sand
1/2 0.0098	0.25	Fine sand
1/4 0.005	0.125	Very fine sand
1/8 0.0025	0.0625	
1/16 0.0012	0.031	Coarse silt
1/32 0.00061	0.0156	Medium silt
1/64 0.00031	0.0078	Fine silt
1/128 0.00015	0.0039	Very fine silt
		Clay

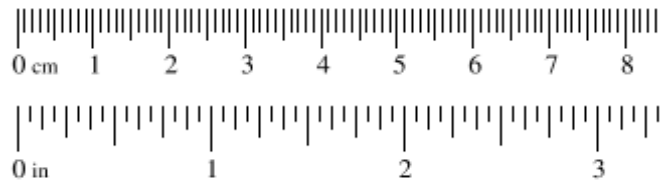

Project ID: _____ Cross section ID: _____ Date: _____ Time: _____

Cross section drawing:

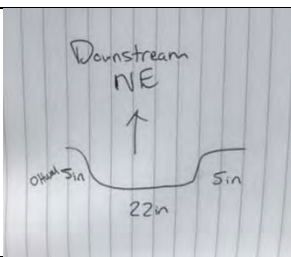

OHWM

GPS point: _____

Indicators:

- Change in average sediment texture
- Change in vegetation species
- Change in vegetation cover
- Break in bank slope
- Other: _____
- Other: _____

Comments:

Floodplain unit:

- Low-Flow Channel
- Active Floodplain
- Low Terrace

GPS point: _____

Characteristics of the floodplain unit:

Average sediment texture: Fine dirt

Total veg cover: 5 % Tree: 0 % Shrub 0 % Herb: 5 %

Community successional stage:

- NA
- Early (herbaceous & seedlings)
- Mid (herbaceous, shrubs, saplings)
- Late (herbaceous, shrubs, mature trees)

Indicators:

- Mudcracks
- Ripples
- Drift and/or debris
- Presence of bed and bank
- Benches
- Soil development
- Surface relief
- Other: _____
- Other: _____
- Other: _____

Comments:



Arcadis U.S., Inc.

1004 N. Big Spring Street

Suite 300

Midland, TX 79701

Tel 432 687 5400

www.arcadis.com

MEMORANDUM OF SURFACE USE AND COMPENSATION AGREEMENT

This Memorandum of Surface Use and Compensation Agreement as of November 1, 2023 by and between **LIMESTONE BASIN PROPERTIES RANCH, LLC** at 6 Desta Drive, Suite 2725, Midland, Texas 79705 (“Surface Owner”) and **CHEVRON U.S.A. INC.**, at 6301 Deauville Blvd, Midland, Texas 79706 (“Operator”).

1. Surface Owner and Operator entered into a Surface Use and Compensation Agreement, dated effective November 1, 2023 (the “Agreement”). The Agreement shall continue for as long thereafter as Operator conducts drilling, completing, production and/or other oil and gas Operations on the Lands or on Associated Wells, with no cessation of more than one hundred eighty (180) consecutive days, and further subject to the terms and provisions therein, and so long as Operator has timely tendered to Surface Owner all payments due under the Agreement and Operator is not otherwise in default under the Agreement.

2. The real property covered by the terms of the Agreement are those described in **Exhibit A** hereto (the “Land(s)”).

3. The Agreement provides the terms and conditions and compensation related to Operator’s use of the Lands. The terms, conditions and covenants of the Agreement are set forth at length in the Agreement and are incorporated herein by reference as though fully set forth herein. This Memorandum shall not, in any manner or form whatsoever, alter, modify or vary the terms, covenants and conditions of the Agreement. A copy of the Agreement is on file with Surface Owner.

4. The terms, covenants and provisions of the Agreement, of which this is a Memorandum, shall extend to and be binding upon the respective successors and assigns of Surface Owner and Operator, as assignment is allowed in accordance with the terms of the Agreement.

IN WITNESS WHEREOF, hereunto and to duplicates hereof, Surface Owner and Operator have caused this Memorandum to be duly executed.

[Signature Page Follows]

SURFACE OWNER:

LIMESTONE BASIN PROPERTIES RANCH, LLC



By: Jared Slade
Title: Chief Land Officer

OPERATOR:

CHEVRON U.S.A. INC.

By: Todd Meade
Title: Attorney-in-Fact

ACKNOWLEDGEMENT

STATE OF OKLAHOMA §
 §
COUNTY OF TULSA §

This instrument was acknowledged before me on this 14th day of December, 2023 by Jared Slade, Chief Land Officer, on behalf of Limestone Basin Properties Ranch, LLC, a limited liability company, on behalf of said company.

My Commission Expires:



Notary Public, State of Oklahoma

STATE OF TEXAS §
 §
COUNTY OF MIDLAND §

This instrument was acknowledged before me this _____ day of _____, 2023 by Todd Meade, Attorney-in-Fact for Chevron U.S.A. Inc., a Pennsylvania corporation, on behalf of said corporation.

My Commission Expires:

Notary Public, State of Texas

SURFACE OWNER:

LIMESTONE BASIN PROPERTIES RANCH, LLC

By: Jared Slade
Title: Chief Land Officer

OPERATOR:

CHEVRON U.S.A. INC.

By: Todd Meade
Title: Attorney-in-Fact

ACKNOWLEDGEMENT

STATE OF OKLAHOMA §
 §
 §
COUNTY OF TULSA §

This instrument was acknowledged before me on this _____ day of _____, 2023 by Jared Slade, Chief Land Officer, on behalf of Limestone Basin Properties Ranch, LLC, a limited liability company, on behalf of said company.

My Commission Expires: _____
Notary Public, State of Oklahoma

STATE OF TEXAS §
 §
 §
COUNTY OF MIDLAND §

This instrument was acknowledged before me this 15th day of December, 2023 by Todd Meade, Attorney-in-Fact for Chevron U.S.A. Inc., a Pennsylvania corporation, on behalf of said corporation.

My Commission Expires: 12/23/25



Notary Public, State of Texas



EXHIBIT A – (the “Land(s)”)

Township 23 South, Range 34 East, Lea County, New Mexico

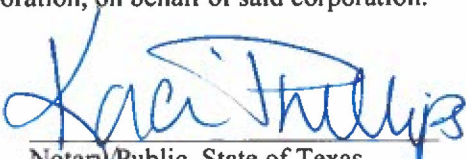
Section 21: All

Section 28: All

Section 29: All

Section 31: All

Section 32: All

Section 33: All

Section 34: All, save and except the NW/4SW4

Section 35: All

From: [Stone, Joel, EMNRD](#)
To: akenney@chevron.com
Subject: ZN 34 3 FED COM (Pad 13) (419H, 420H, 421H, 619H, 620H, 621H), [FJZS2606258391] Temporary Pit
Date: Tuesday, March 3, 2026 4:28:00 PM
Attachments: [app_554117_1362707.pdf](#)

**ZN 34 3 FED COM (Pad 13) (419H, 420H, 421H, 619H, 620H, 621H), [FJZS2606258391].
TEMPORARY PIT NON-LOW CHLORIDE FLUIDS.**

NMOCD has reviewed and approved [4323] CHEVRON USA INC's Application and Form C-144 received on 02/16/2026, for the proposed ZN 34 3 FED COM (Pad 13) (419H, 420H, 421H, 619H, 620H, 621H), [FJZS2606258391] Temporary Pit with non-low chloride drilling fluid located in Unit Letter A, Section 34, Township 23S, Range 34E, Lea County, New Mexico.

[4323] CHEVRON USA INC in the Application requested the following two variances from the requirements of 19.15.17 NMAC – Pits, Closed-Loop Systems, Below-Grade Tanks and Sumps:

1. [4323] CHEVRON USA INC proposes a closure timeline based on the date of the first occurrence of Rig Down Move Out (RDMO). RDMO is defined as the activity when the drilling rig is moved off location. Typically, RDMO occurs after the completion of drilling the last well on the pad. On pads where the Operator plans to return to the pad, multiple RDMO dates occur. This variance does not consider subsequent RDMO affecting the closure timeline dates after the first RDMO. The Operator proposes dewatering the pit within 30 days of RDMO and proposes closing the pits within 1 year of RDMO.
2. [4323] CHEVRON USA INC proposes the use of 40-mil High-Density Polyethylene (HDPE) Liner for Temporary Pit in lieu of 20 mil string reinforced Linear Low-Density Polyethylene (LLDPE) Liner.

Subject to the conditions specified below, NMOCD approves the following variances:

1. The variance from 19.15.17.7.R NMAC, which requires that a pit be closed no later than six (6) months after removal of the drilling or workover rig from the first well using the pit.
2. The variance from 19.15.17.11.F.3 NMAC, which requires the pit to be equipped with a 20- mil string reinforced LLDPE or equivalent liner material that the appropriate division district office approves.

[4323] CHEVRON USA INC shall comply with the following conditions of approval:

1. [4323] CHEVRON USA INC shall design, construct, operate, maintain, and close ZN 34 3 FED COM (Pad 13) (419H, 420H, 421H, 619H, 620H, 621H), [FJZS2606258391] Pit in compliance with 19.15.17 NMAC - Pits, Closed-Loop Systems, Below-Grade-Tanks and

Sumps.

2. The design and construction plan, included in the Application, is approved. [4323] CHEVRON USA INC shall design and construct ZN 34 3 FED COM (Pad 13) (419H, 420H, 421H, 619H, 620H, 621H), [FJZS2606258391] Pit as described in the approved plan. [4323] CHEVRON USA INC shall apply for a permit modification for any change to the plan.
3. The closure plan, included as Appendix F of the Application, is approved. [4323] CHEVRON USA INC shall close the ZN 34 3 FED COM (Pad 13) (419H, 420H, 421H, 619H, 620H, 621H), [FJZS2606258391] Pit as described in the approved plan. [4323] CHEVRON USA INC shall apply for a permit modification for any change to the plan.
4. Prior to commencing construction of the ZN 34 3 FED COM (Pad 13) (419H, 420H, 421H, 619H, 620H, 621H), [FJZS2606258391] Pit, [4323] CHEVRON USA INC shall submit to OCD a Form C-102, including a certified survey, as required by 19.15.17.9(C) (2) NMAC via OCD Online.
5. [4323] CHEVRON USA INC shall inspect ZN 34 3 FED COM (Pad 13) (419H, 420H, 421H, 619H, 620H, 621H), [FJZS2606258391] Pit at least once per month during construction for compliance with the approved design and construction plan. [4323] CHEVRON USA INC shall maintain a log of each inspection and provide a copy of the log through OCD Online for each quarter beginning fifteen days (15) after the end of the quarter during construction.
6. If [4323] CHEVRON USA INC encounters a void or collapse during construction, operation, maintenance, or closure of the ZN 34 3 FED COM (Pad 13) (419H, 420H, 421H, 619H, 620H, 621H), [FJZS2606258391] Pit, [4323] CHEVRON USA INC shall immediately cease the activity, notify OCD through OCD Online, within twenty-four (24) hours, and take corrective action approved by OCD.
7. No later than seventy-two (72) hours prior to installing the 40-mil HDPE liner, [4323] CHEVRON USA INC shall notify the OCD through OCD Online.
8. [4323] CHEVRON USA INC shall inspect ZN 34 3 FED COM (Pad 13) (419H, 420H, 421H, 619H, 620H, 621H), [FJZS2606258391] Pit at least once per day for liner integrity, freeboard height, fluid level, debris, migratory birds and other wildlife, and releases while the drilling or workover rig is on location, and once per week after removal of the rig but prior to dewatering the ZN 34 3 FED COM (Pad 13) (419H, 420H, 421H, 619H, 620H, 621H), [FJZS2606258391] Pit. [4323] CHEVRON USA INC shall maintain a log of each inspection and provide a copy of the log through OCD Online for each quarter beginning fifteen days (15) after the end of the quarter during construction.
9. [4323] CHEVRON USA INC shall maintain no less than two (2) feet of freeboard at the Pit at all times.
10. [4323] CHEVRON USA INC shall construct and maintain a fence around the perimeter of the ZN 34 3 FED COM (Pad 13) (419H, 420H, 421H, 619H, 620H, 621H),

[FJZS2606258391] Pit at all times after the completion of construction.

11. No later than thirty (30) days after the date of any of the following events, [4323] CHEVRON USA INC shall drain and dewater ZN 34 3 FED COM (Pad 13) (419H, 420H, 421H, 619H, 620H, 621H), [FJZS2606258391] Pit:

a. The release of the drilling or workover rig from the last well as reported to the OCD on Form C-105; or

b. The removal of the drilling or workover rig from the pad if the well is not completed; or

c. If the drilling or workover rig is located at the pad, one hundred eight one (181) days after the rig became inactive.

12. No later than six (6) months after the date of any of the following events, [4323] CHEVRON USA INC shall close ZN 34 3 FED COM (Pad 13) (419H, 420H, 421H, 619H, 620H, 621H), [FJZS2606258391]:

a. The release of the drilling or workover rig from the last well as reported to the OCD on Form C-105; or

b. The removal of the drilling or workover rig from the pad if the well is not completed; or

c. If the drilling or workover rig is located at the pad, one hundred eight one (181) days after the rig became inactive.

13. After [4323] CHEVRON USA INC drains ZN 34 3 FED COM (Pad 13) (419H, 420H, 421H, 619H, 620H, 621H), [FJZS2606258391] Pit, it shall inspect the Pit for liner integrity, fluid level, debris, migratory birds and other wildlife, and releases once per week until the installation of the top geomembrane cover and the placement of the cover soils in accordance with the closure plan. [4323] CHEVRON USA INC shall maintain a log of each inspection and provide a copy of the log to OCD via OCD Online for each quarter beginning fifteen days (15) days after the end of the quarter in which the Pit is dewatered and drained. If [4323] CHEVRON USA INC observes fluid in the ZN 34 3 FED COM (Pad 13) (419H, 420H, 421H, 619H, 620H, 621H), [FJZS2606258391] Pit during an inspection, it shall notify OCD's Environmental Bureau at through OCD Online, remove the fluid immediately, and submit a report characterizing the nature, volume, and source of the fluid via OCD Online.

14. After [4323] CHEVRON USA INC has drained and dewatered ZN 34 3 FED COM (Pad 13) (419H, 420H, 421H, 619H, 620H, 621H), [FJZS2606258391] Pit, [4323] CHEVRON USA INC shall not discharge fluid into the Pit for any purpose except for an emergency as provided in 19.15.17.14 NMAC.

15. [4323] CHEVRON USA INC shall comply with 19.15.29 NMAC - Releases for any release related to or associated with the ZN 34 3 FED COM (Pad 13) (419H, 420H, 421H, 619H, 620H, 621H), [FJZS2606258391] Pit.

16. No later than seventy-two (72) hours prior to installing the top geomembrane cover

and cover soil on the ZN 34 3 FED COM (Pad 13) (419H, 420H, 421H, 619H, 620H, 621H), [FJZS2606258391] Pit, [4323] CHEVRON USA INC shall notify the OCD via OCD Online. 17. Once the NMOCD has issued the corresponding API numbers, [4323] CHEVRON USA INC shall provide the NMOCD with the API numbers for all wells associated with the ZN 34 3 FED COM (Pad 13) (419H, 420H, 421H, 619H, 620H, 621H), [FJZS2606258391] Pit.

This letter constitutes NMOCD's conditions of approval of the variances. Please reference ZN 34 3 FED COM (Pad 13) (419H, 420H, 421H, 619H, 620H, 621H), [FJZS2606258391], in all future communications. Please let me know if you have any additional questions or concerns.

Respectfully,

Joel B. Stone • Senior Environmental Scientist
Energy, Minerals and Natural Resources Department
Oil Conservation Division
1220 S. St. Francis Drive, Santa Fe, NM 87505
(505) 709-5149 | joel.stone@emnrd.nm.gov

Sante Fe Main Office
Phone: (505) 476-3441

General Information
Phone: (505) 629-6116

Online Phone Directory
<https://www.emnrd.nm.gov/ocd/contact-us>

State of New Mexico
Energy, Minerals and Natural Resources
Oil Conservation Division
1220 S. St Francis Dr.
Santa Fe, NM 87505

CONDITIONS

Action 554117

CONDITIONS

Operator: CHEVRON U S A INC 6301 Deauville Blvd Midland, TX 79706	OGRID: 4323
	Action Number: 554117
	Action Type: [C-144] Temporary Pit Plan (C-144T)

CONDITIONS

Created By	Condition	Condition Date
joel.stone	NMOCD has reviewed and approved [4323] CHEVRON USA INC's Application and Form C-144 received on 02/16/2026, for the proposed ZN 34 3 FED COM (Pad 13) (419H, 420H, 421H, 619H, 620H, 621H), [FJZS2606258391] Temporary Pit with non-low chloride drilling fluid located in Unit Letter A, Section 34, Township 23S, Range 34E, Lea County, New Mexico. Please reference ZN 34 3 FED COM (Pad 13) (419H, 420H, 421H, 619H, 620H, 621H), [FJZS2606258391], in all future communications. OCD letter outlining conditions has been emailed to the operator and uploaded with this approval.	3/3/2026