

Form 3160-3
(June 2015)

FORM APPROVED
OMB No. 1004-0137
Expires: January 31, 2018

UNITED STATES
DEPARTMENT OF THE INTERIOR
BUREAU OF LAND MANAGEMENT
APPLICATION FOR PERMIT TO DRILL OR REENTER

1a. Type of work: <input type="checkbox"/> DRILL <input type="checkbox"/> REENTER		5. Lease Serial No.
1b. Type of Well: <input type="checkbox"/> Oil Well <input type="checkbox"/> Gas Well <input type="checkbox"/> Other		6. If Indian, Allottee or Tribe Name
1c. Type of Completion: <input type="checkbox"/> Hydraulic Fracturing <input type="checkbox"/> Single Zone <input type="checkbox"/> Multiple Zone		7. If Unit or CA Agreement, Name and No.
2. Name of Operator [260297]		8. Lease Name and Well No. [331335]
3a. Address	3b. Phone No. (include area code)	9. API Well No. 30-025-49299
4. Location of Well (Report location clearly and in accordance with any State requirements. *) At surface At proposed prod. zone		10. Field and Pool, or Exploratory [51020]
14. Distance in miles and direction from nearest town or post office*		11. Sec., T. R. M. or Blk. and Survey or Area
15. Distance from proposed* location to nearest property or lease line, ft. (Also to nearest drig. unit line, if any)		12. County or Parish
16. No of acres in lease		13. State
17. Spacing Unit dedicated to this well		
18. Distance from proposed location* to nearest well, drilling, completed, applied for, on this lease, ft.		19. Proposed Depth
20. BLM/BIA Bond No. in file		
21. Elevations (Show whether DF, KDB, RT, GL, etc.)	22. Approximate date work will start*	23. Estimated duration
24. Attachments		

The following, completed in accordance with the requirements of Onshore Oil and Gas Order No. 1, and the Hydraulic Fracturing rule per 43 CFR 3162.3-3 (as applicable)

- | | |
|---|---|
| <ul style="list-style-type: none"> 1. Well plat certified by a registered surveyor. 2. A Drilling Plan. 3. A Surface Use Plan (if the location is on National Forest System Lands, the SUPO must be filed with the appropriate Forest Service Office). | <ul style="list-style-type: none"> 4. Bond to cover the operations unless covered by an existing bond on file (see Item 20 above). 5. Operator certification. 6. Such other site specific information and/or plans as may be requested by the BLM. |
|---|---|

25. Signature	Name (Printed/Typed)	Date
Title		
Approved by (Signature)	Name (Printed/Typed)	Date
Title		Office

Application approval does not warrant or certify that the applicant holds legal or equitable title to those rights in the subject lease which would entitle the applicant to conduct operations thereon.
Conditions of approval, if any, are attached.

Title 18 U.S.C. Section 1001 and Title 43 U.S.C. Section 1212, make it a crime for any person knowingly and willfully to make to any department or agency of the United States any false, fictitious or fraudulent statements or representations as to any matter within its jurisdiction.

NGMP Rec 08/09/2021

KZ
08/11/2021

SL



(Continued on page 2)

*(Instructions on page 2)

DISTRICT I
1625 N. French Dr., Hobbs, NM 88240
Phone (575) 393-6161 Fax: (575) 393-0720

DISTRICT II
811 S. First St., Artesia, NM 88210
Phone (575) 748-1283 Fax: (575) 748-9720

DISTRICT III
1000 Rio Brazos Road, Aztec, NM 87410
Phone (505) 334-6178 Fax: (505) 334-6170

DISTRICT IV
1220 S. St. Francis Dr., Santa Fe, NM 87505
Phone: (505) 476-3460 Fax: (505) 476-3462

State of New Mexico
Energy, Minerals & Natural Resources Department

OIL CONSERVATION DIVISION

1220 South St. Francis Dr.
Santa Fe, New Mexico 87505

Form C-102

Revised August 1, 2011

Submit one copy to appropriate
District Office

AMENDED REPORT

WELL LOCATION AND ACREAGE DEDICATION PLAT

API Number 30-025-49299	Pool Code 51020	Pool Name RED HILLS;LWR BONE SPRING
Property Code 331335	Property Name ROJO 7811 22 FEDERAL	Well Number 73H
OGRID No. 260297	Operator Name BTA OIL PRODUCERS, LLC	Elevation 3369'

Surface Location

UL or lot No.	Section	Township	Range	Lot Idn	Feet from the	North/South line	Feet from the	East/West line	County
D	22	25-S	33-E		310	NORTH	645	WEST	LEA

Bottom Hole Location If Different From Surface

UL or lot No.	Section	Township	Range	Lot Idn	Feet from the	North/South line	Feet from the	East/West line	County
M	22	25-S	33-E		50	SOUTH	350	WEST	LEA

Dedicated Acres 160	Joint or Infill	Consolidation Code	Order No.
-------------------------------	-----------------	--------------------	-----------

NO ALLOWABLE WILL BE ASSIGNED TO THIS COMPLETION UNTIL ALL INTERESTS HAVE BEEN CONSOLIDATED OR A NON-STANDARD UNIT HAS BEEN APPROVED BY THE DIVISION

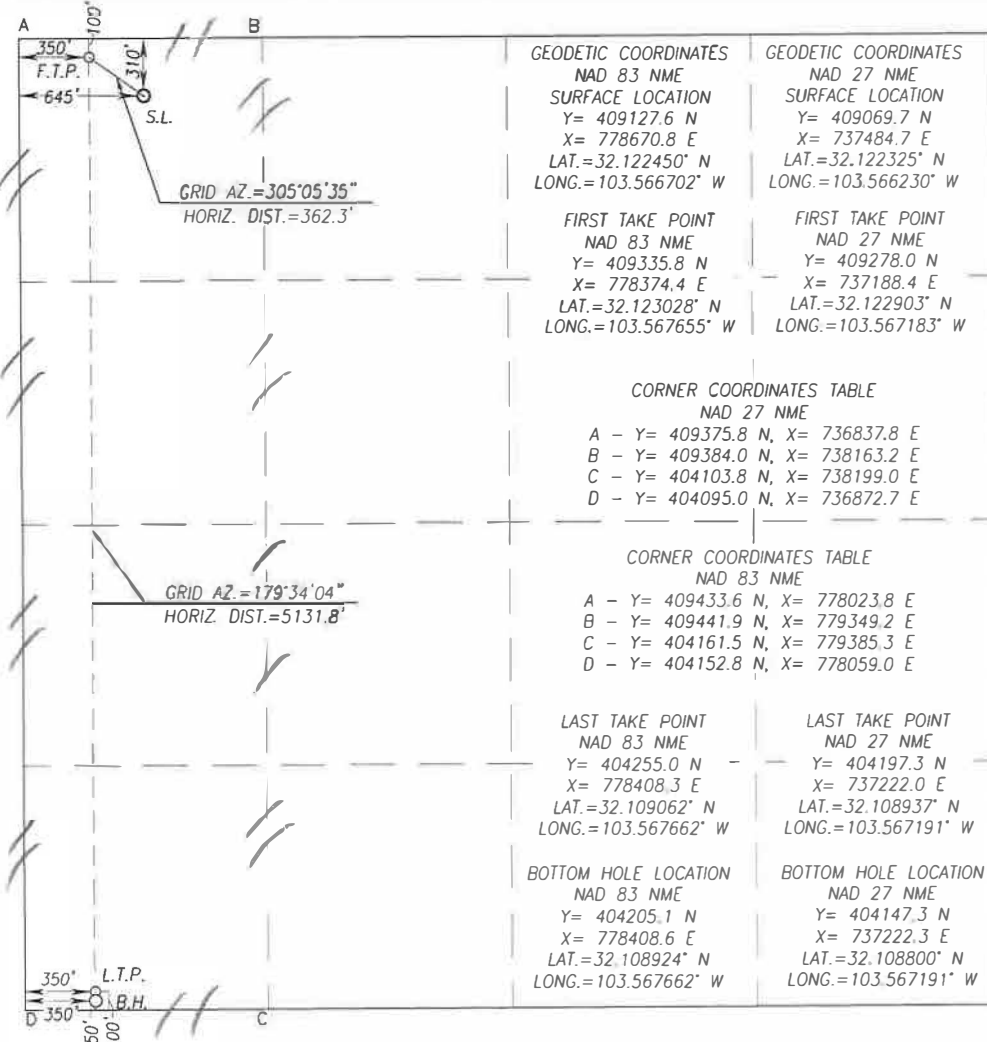

OPERATOR CERTIFICATION

I hereby certify that the information herein is true and complete to the best of my knowledge and belief, and that this organization either owns a working interest or unleased mineral interest in the land including the proposed bottom hole location or has a right to drill this well at this location pursuant to a contract with an owner of such mineral or working interest, or to a voluntary pooling agreement or a compulsory pooling order heretofore entered by the division

Sammy Hajar 10/13/2020
Signature Date

Sammy Hajar
Printed Name
SHAJAR@BTAOIL.COM
E-mail Address

SURVEYOR CERTIFICATION

I hereby certify that the well location shown on this plat was plotted from field notes of actual surveys made by me or under my supervision, and that the same is true and correct to the best of my belief.

Date of Survey **JUL 07, 2020**
Signature of Professional Surveyor
Ronald J. Eidson
NEW MEXICO
REGISTERED PROFESSIONAL SURVEYOR
3239
Ronald J. Eidson 09/24/2020
Certificate Number Gary G. Eidson 12641
Ronald J. Eidson 3239
I.S.L. JWSC W.O. 20 11 0323

PECOS DISTRICT DRILLING CONDITIONS OF APPROVAL

OPERATOR'S NAME:	BTA OIL PRODUCERS LLC
LEASE NO.:	NMNM015091
WELL NAME & NO.:	ROJO 7811 22 FEDERAL 73H
SURFACE HOLE FOOTAGE:	310'/N & 645'/W
BOTTOM HOLE FOOTAGE:	50'/S & 350'/W
LOCATION:	Section 22, T.25 S., R.33 E., NMP
COUNTY:	Lea County, New Mexico

COA

H2S	<input checked="" type="radio"/> Yes	<input type="radio"/> No	
Potash	<input checked="" type="radio"/> None	<input type="radio"/> Secretary	<input type="radio"/> R-111-P
Cave/Karst Potential	<input checked="" type="radio"/> Low	<input type="radio"/> Medium	<input type="radio"/> High
Cave/Karst Potential	<input type="radio"/> Critical		
Variance	<input type="radio"/> None	<input checked="" type="radio"/> Flex Hose	<input type="radio"/> Other
Wellhead	<input type="radio"/> Conventional	<input type="radio"/> Multibowl	<input checked="" type="radio"/> Both
Other	<input type="checkbox"/> 4 String Area	<input type="checkbox"/> Capitan Reef	<input type="checkbox"/> WIPP
Other	<input checked="" type="checkbox"/> Fluid Filled	<input type="checkbox"/> Cement Squeeze	<input type="checkbox"/> Pilot Hole
Special Requirements	<input type="checkbox"/> Water Disposal	<input type="checkbox"/> COM	<input type="checkbox"/> Unit

A. HYDROGEN SULFIDE

A Hydrogen Sulfide (H2S) Drilling Plan shall be activated 500 feet prior to drilling into the Undesignated formation in the Wildcat Pool. As a result, the Hydrogen Sulfide area must meet Onshore Order 6 requirements, which includes equipment and personnel/public protection items. If Hydrogen Sulfide is encountered, please provide measured values and formations to the BLM.

B. CASING

Casing Design:

1. The **13-3/8** inch surface casing shall be set at approximately **1,350** feet (a minimum of **25 feet (Lea County)**) into the Rustler Anhydrite and above the salt) and cemented to the surface.
 - a. If cement does not circulate to the surface, the appropriate BLM office shall be notified and a temperature survey utilizing an electronic type temperature survey with surface log readout will be used or a cement bond log shall be run to verify the top of the cement. Temperature survey will be run a minimum of six hours after pumping cement and ideally between 8-10 hours after

- completing the cement job.
- b. Wait on cement (WOC) time for a primary cement job will be a minimum of **8 hours** or 500 pounds compressive strength, whichever is greater. (This is to include the lead cement)
 - c. Wait on cement (WOC) time for a remedial job will be a minimum of 4 hours after bringing cement to surface or 500 pounds compressive strength, whichever is greater.
 - d. If cement falls back, remedial cementing will be done prior to drilling out that string.

Intermediate casing must be kept fluid filled to meet BLM minimum collapse requirement.

2. The minimum required fill of cement behind the **9-5/8** inch intermediate casing, which shall be set at approximately **4,983** feet is:
 - Cement to surface. If cement does not circulate see B.1.a, c-d above.
3. The minimum required fill of cement behind the **5-1/2** inch production casing is:
 - Cement should tie-back at least **200 feet** into previous casing string. Operator shall provide method of verification.

C. PRESSURE CONTROL

1. Variance approved to use flex line from BOP to choke manifold. Manufacturer's specification to be readily available. No external damage to flex line. Flex line to be installed as straight as possible (no hard bends).'
- 2.

Option 1:

- a. Minimum working pressure of the blowout preventer (BOP) and related equipment (BOPE) required for drilling below the surface casing shoe shall be **2000 (2M)** psi.
- b. Minimum working pressure of the blowout preventer (BOP) and related equipment (BOPE) required for drilling below the intermediate casing shoe shall be **5000 (5M)** psi.

Option 2:

1. Operator has proposed a multi-bowl wellhead assembly. This assembly will only be tested when installed on the surface casing. Minimum working pressure of the blowout preventer (BOP) and related equipment (BOPE) required for drilling below the surface casing shoe shall be **5000 (5M)** psi.
 - a. Wellhead shall be installed by manufacturer's representatives, submit documentation with subsequent sundry.
 - b. If the welding is performed by a third party, the manufacturer's representative shall monitor the temperature to verify that it does not exceed the maximum temperature of the seal.
 - c. Manufacturer representative shall install the test plug for the initial BOP test.
 - d. If the cement does not circulate and one inch operations would have been possible with a standard wellhead, the well head shall be cut off, cementing operations performed and another wellhead installed.
 - e. Whenever any seal subject to test pressure is broken, all the tests in OOGO2.III.A.2.i must be followed.

D. SPECIAL REQUIREMENT (S)**BOP Break Testing Variance (Note: For 5M BOP or less)**

- BOPE Break Testing is ONLY permitted for 5M BOPE or less.
- BOPE Break Testing is NOT permitted to drilling the production hole section.
- While in transfer between wells, the BOPE shall be secured by the hydraulic carrier or cradle.
- Any well control event while drilling require notification to the BLM Petroleum Engineer prior to the commencement of any BOPE Break Testing operations.
- A full BOPE test is required prior to drilling the first deep intermediate hole section. If any subsequent hole interval is deeper than the first, a full BOPE test will be required.
- The BLM is to be contacted (575-361-2822 Eddy County) (575-393-3612 Lea County) 4 hours prior to BOPE tests.
- As a minimum, a full BOPE test shall be performed at 21-day intervals.
- In the event any repairs or replacement of the BOPE is required, the BOPE shall test as per Onshore Oil and Gas Order No. 2.

GENERAL REQUIREMENTS

The BLM is to be notified in advance for a representative to witness:

- a. Spudding well (minimum of 24 hours)
- b. Setting and/or Cementing of all casing strings (minimum of 4 hours)
- c. BOPE tests (minimum of 4 hours)

Eddy County

Call the Carlsbad Field Office, 620 East Greene St., Carlsbad, NM 88220,
(575) 361-2822

Lea County

Call the Hobbs Field Station, 414 West Taylor, Hobbs NM 88240,
(575) 393-3612

1. Unless the production casing has been run and cemented or the well has been properly plugged, the drilling rig shall not be removed from over the hole without prior approval.
 - a. In the event the operator has proposed to drill multiple wells utilizing a skid/walking rig. Operator shall secure the wellbore on the current well, after installing and testing the wellhead, by installing a blind flange of like pressure rating to the wellhead and a pressure gauge that can be monitored while drilling is performed on the other well(s).
 - b. When the operator proposes to set surface casing with Spudder Rig
 - Notify the BLM when moving in and removing the Spudder Rig.
 - Notify the BLM when moving in the 2nd Rig. Rig to be moved in within 90 days of notification that Spudder Rig has left the location.
 - BOP/BOPE test to be conducted per Onshore Oil and Gas Order No. 2 as soon as 2nd Rig is rigged up on well.
2. Floor controls are required for 3M or Greater systems. These controls will be on the rig floor, unobstructed, readily accessible to the driller and will be operational at all times during drilling and/or completion activities. Rig floor is defined as the area immediately around the rotary table; the area immediately above the substructure on which the draw works are located, this does not include the dog house or stairway area.
3. The record of the drilling rate along with the GR/N well log run from TD to surface (horizontal well – vertical portion of hole) shall be submitted to the BLM office as well as all other logs run on the borehole 30 days from completion. If available, a digital copy of the logs is to be submitted in addition to the paper copies. The Rustler top and top and bottom of Salt are to be recorded on the Completion Report.

A. CASING

1. Changes to the approved APD casing program need prior approval if the items substituted are of lesser grade or different casing size or are Non-API. The Operator can exchange the components of the proposal with that of superior strength (i.e. changing from J-55 to N-80, or from 36# to 40#). Changes to the approved cement program need prior approval if the altered cement plan has less volume or strength or if the changes are substantial (i.e. Multistage tool, ECP, etc.). The initial wellhead installed on the well will remain on the well with spools used as needed.
2. Wait on cement (WOC) for Potash Areas: After cementing but before commencing any tests, the casing string shall stand cemented under pressure until both of the following conditions have been met: 1) cement reaches a minimum compressive strength of 500 psi for all cement blends, 2) until cement has been in place at least 24 hours. WOC time will be recorded in the driller's log. The casing integrity test can be done (prior to the cement setting up) immediately after bumping the plug.
3. Wait on cement (WOC) for Water Basin: After cementing but before commencing any tests, the casing string shall stand cemented under pressure until both of the following conditions have been met: 1) cement reaches a minimum compressive strength of 500 psi at the shoe, 2) until cement has been in place at least 8 hours. WOC time will be recorded in the driller's log. See individual casing strings for details regarding lead cement slurry requirements. The casing integrity test can be done (prior to the cement setting up) immediately after bumping the plug.
4. Provide compressive strengths including hours to reach required 500 pounds compressive strength prior to cementing each casing string. Have well specific cement details onsite prior to pumping the cement for each casing string.
5. No pea gravel permitted for remedial or fall back remedial without prior authorization from the BLM engineer.
6. On that portion of any well approved for a 5M BOPE system or greater, a pressure integrity test of each casing shoe shall be performed. Formation at the shoe shall be tested to a minimum of the mud weight equivalent anticipated to control the formation pressure to the next casing depth or at total depth of the well. This test shall be performed before drilling more than 20 feet of new hole.
7. If hardband drill pipe is rotated inside casing, returns will be monitored for metal. If metal is found in samples, drill pipe will be pulled and rubber protectors which have a larger diameter than the tool joints of the drill pipe will be installed prior to continuing drilling operations.
8. Whenever a casing string is cemented in the R-111-P potash area, the NMOCD requirements shall be followed.

B. PRESSURE CONTROL

1. All blowout preventer (BOP) and related equipment (BOPE) shall comply with well control requirements as described in Onshore Oil and Gas Order No. 2 and API RP 53 Sec. 17.
2. If a variance is approved for a flexible hose to be installed from the BOP to the choke manifold, the following requirements apply: The flex line must meet the requirements of API 16C. Check condition of flexible line from BOP to choke manifold, replace if exterior is damaged or if line fails test. Line to be as straight as possible with no hard bends and is to be anchored according to Manufacturer's requirements. The flexible hose can be exchanged with a hose of equal size and equal or greater pressure rating. Anchor requirements, specification sheet and hydrostatic pressure test certification matching the hose in service, to be onsite for review. These documents shall be posted in the company man's trailer and on the rig floor.
3. 5M or higher system requires an HCR valve, remote kill line and annular to match. The remote kill line is to be installed prior to testing the system and tested to stack pressure.
4. If the operator has proposed a multi-bowl wellhead assembly in the APD. The following requirements must be met:
 - a. Wellhead shall be installed by manufacturer's representatives, submit documentation with subsequent sundry.
 - b. If the welding is performed by a third party, the manufacturer's representative shall monitor the temperature to verify that it does not exceed the maximum temperature of the seal.
 - c. Manufacturer representative shall install the test plug for the initial BOP test.
 - d. Whenever any seal subject to test pressure is broken, all the tests in OOGO2.III.A.2.i must be followed.
 - e. If the cement does not circulate and one inch operations would have been possible with a standard wellhead, the well head shall be cut off, cementing operations performed and another wellhead installed.
5. The appropriate BLM office shall be notified a minimum of 4 hours in advance for a representative to witness the tests.
 - a. In a water basin, for all casing strings utilizing slips, these are to be set as soon as the crew and rig are ready and any fallback cement remediation has been done. The casing cut-off and BOP installation can be initiated four hours after installing the slips, which will be approximately six hours after bumping the plug. For those casing strings not using slips, the minimum wait time before cut-off is eight hours after bumping the plug. BOP/BOPE testing can begin after cut-off or once cement reaches 500 psi compressive strength (including

lead when specified), whichever is greater. However, if the float does not hold, cut-off cannot be initiated until cement reaches 500 psi compressive strength (including lead when specified).

- b. In potash areas, for all casing strings utilizing slips, these are to be set as soon as the crew and rig are ready and any fallback cement remediation has been done. For all casing strings, casing cut-off and BOP installation can be initiated at twelve hours after bumping the plug. However, **no tests** shall commence until the cement has had a minimum of 24 hours setup time, except the casing pressure test can be initiated immediately after bumping the plug (only applies to single stage cement jobs).
- c. The tests shall be done by an independent service company utilizing a test plug not a cup or J-packer. The operator also has the option of utilizing an independent tester to test without a plug (i.e. against the casing) pursuant to Onshore Order 2 with the pressure not to exceed 70% of the burst rating for the casing. Any test against the casing must meet the WOC time for water basin (8 hours) or potash (24 hours) or 500 pounds compressive strength, whichever is greater, prior to initiating the test (see casing segment as lead cement may be critical item).
- d. The test shall be run on a 5000 psi chart for a 2-3M BOP/BOP, on a 10000 psi chart for a 5M BOP/BOPE and on a 15000 psi chart for a 10M BOP/BOPE. If a linear chart is used, it shall be a one hour chart. A circular chart shall have a maximum 2 hour clock. If a twelve hour or twenty-four hour chart is used, tester shall make a notation that it is run with a two hour clock.
- e. The results of the test shall be reported to the appropriate BLM office.
- f. All tests are required to be recorded on a calibrated test chart. A copy of the BOP/BOPE test chart and a copy of independent service company test will be submitted to the appropriate BLM office.
- g. The BOP/BOPE test shall include a low pressure test from 250 to 300 psi. The test will be held for a minimum of 10 minutes if test is done with a test plug and 30 minutes without a test plug. This test shall be performed prior to the test at full stack pressure.
- h. BOP/BOPE must be tested by an independent service company within 500 feet of the top of the Wolfcamp formation if the time between the setting of the intermediate casing and reaching this depth exceeds 20 days. This test does not exclude the test prior to drilling out the casing shoe as per Onshore Order No. 2.

C. DRILLING MUD

Mud system monitoring equipment, with derrick floor indicators and visual and audio alarms, shall be operating before drilling into the Wolfcamp formation, and shall be used until production casing is run and cemented.

D. WASTE MATERIAL AND FLUIDS

All waste (i.e. drilling fluids, trash, salts, chemicals, sewage, gray water, etc.) created as a result of drilling operations and completion operations shall be safely contained and disposed of properly at a waste disposal facility. No waste material or fluid shall be disposed of on the well location or surrounding area.

Porto-johns and trash containers will be on-location during fracturing operations or any other crew-intensive operations.

OTA06142021



U.S. Department of the Interior
BUREAU OF LAND MANAGEMENT

Operator Certification Data Report

07/20/2021

Operator Certification

I hereby certify that I, or someone under my direct supervision, have inspected the drill site and access route proposed herein; that I am familiar with the conditions which currently exist; that I have full knowledge of state and Federal laws applicable to this operation; that the statements made in this APD package are, to the best of my knowledge, true and correct; and that the work associated with the operations proposed herein will be performed in conformity with this APD package and the terms and conditions under which it is approved. I also certify that I, or the company I represent, am responsible for the operations conducted under this application. These statements are subject to the provisions of 18 U.S.C. 1001 for the filing of false statements.

NAME: Sammy Hajar

Signed on: 12/11/2020

Title: Regulatory Analyst

Street Address: 104 S. Pecos

City: Midland

State: TX

Zip: 79701

Phone: (432)682-3753

Email address: shajar@btaoil.com

Field Representative

Representative Name:

Street Address:

City:

State:

Zip:

Phone:

Email address:



U.S. Department of the Interior
BUREAU OF LAND MANAGEMENT

Application Data Report

07/20/2021

APD ID: 10400066613

Submission Date: 12/16/2020

Highlighted data
reflects the most
recent changes

Operator Name: BTA OIL PRODUCERS LLC

Well Name: ROJO 7811 22 FEDERAL

Well Number: 73H

[Show Final Text](#)

Well Type: OIL WELL

Well Work Type: Drill

Section 1 - General

APD ID: 10400066613

Tie to previous NOS?

Submission Date: 12/16/2020

BLM Office: Carlsbad

User: Sammy Hajar

Title: Regulatory Analyst

Federal/Indian APD: FED

Is the first lease penetrated for production Federal or Indian? FED

Lease number: NMNM15091

Lease Acres:

Surface access agreement in place?

Allotted?

Reservation:

Agreement in place? NO

Federal or Indian agreement:

Agreement number:

Agreement name:

Keep application confidential? Y

Permitting Agent? NO

APD Operator: BTA OIL PRODUCERS LLC

Operator letter of designation:

Operator Info

Operator Organization Name: BTA OIL PRODUCERS LLC

Operator Address: 104 S. Pecos

Zip: 79701

Operator PO Box:

Operator City: Midland

State: TX

Operator Phone: (432)682-3753

Operator Internet Address:

Section 2 - Well Information

Well in Master Development Plan? NO

Master Development Plan name:

Well in Master SUPO? NO

Master SUPO name:

Well in Master Drilling Plan? NO

Master Drilling Plan name:

Well Name: ROJO 7811 22 FEDERAL

Well Number: 73H

Well API Number:

Field/Pool or Exploratory? Field and Pool

Field Name: WildCat upper
WolfcampPool Name: 2ND BONE
SPRING

Is the proposed well in an area containing other mineral resources? NONE

Operator Name: BTA OIL PRODUCERS LLC

Well Name: ROJO 7811 22 FEDERAL

Well Number: 73H

Is the proposed well in an area containing other mineral resources? NONE

Is the proposed well in a Helium production area? N

Use Existing Well Pad? Y

New surface disturbance? Y

Type of Well Pad: MULTIPLE WELL

Multiple Well Pad Name: ROJO 7811 22 FEDERAL

Number: 71H, 72H, 73H and 74H

Well Class: HORIZONTAL

Number of Legs: 1

Well Work Type: Drill

Well Type: OIL WELL

Describe Well Type:

Well sub-Type: INFILL

Describe sub-type:

Distance to town:

Distance to nearest well: 566 FT

Distance to lease line: 310 FT

Reservoir well spacing assigned acres Measurement: 160 Acres

Well plat: Signed_ROJO_7811_22_Federal_73H_C102_20201211083506.pdf

Well work start Date: 05/06/2021

Duration: 30 DAYS

Section 3 - Well Location Table

Survey Type: RECTANGULAR

Describe Survey Type:

Datum: NAD83

Vertical Datum: NGVD29

Survey number:

Reference Datum: GROUND LEVEL

Wellbore	NS-Foot	NS Indicator	EW-Foot	EW Indicator	Twsp	Range	Section	Aliquot/Lot/Tract	Latitude	Longitude	County	State	Meridian	Lease Type	Lease Number	Elevation	MD	TVD	Will this well produce from this lease?
SHL Leg #1	310	FNL	645	FW L	25S	33E	22	Aliquot NWN W	32.12245	- 103.5667 02	LEA	NEW MEXI CO	NEW MEXI CO	F	NMNM 15091	336 9	0	0	Y
KOP Leg #1	100	FNL	350	FW L	25S	33E	22	Aliquot NWN W	32.12302 8	- 103.5676 55	LEA	NEW MEXI CO	NEW MEXI CO	F	NMNM 15091	- 697 7	103 60	103 46	Y
PPP Leg #1-1	100	FNL	350	FW L	25S	33E	22	Aliquot NWN W	32.12302 8	- 103.5676 55	LEA	NEW MEXI CO	NEW MEXI CO	F	NMNM 15091	- 735 5	107 98	107 24	Y

Operator Name: BTA OIL PRODUCERS LLC

Well Name: ROJO 7811 22 FEDERAL

Well Number: 73H

Wellbore	NS-Foot	NS Indicator	EW-Foot	EW Indicator	Twsp	Range	Section	Aliquot/Lot/Tract	Latitude	Longitude	County	State	Meridian	Lease Type	Lease Number	Elevation	MD	TVD	Will this well produce from this lease?
EXIT Leg #1	100	FSL	350	FW L	25S	33E	22	Aliquot SWS W	32.109062	-103.567662	LEA	NEW MEXI CO	NEW MEXI CO	F	NMNM 15091	-7455	15564	10824	Y
BHL Leg #1	50	FSL	350	FW L	25S	33E	22	Aliquot SWS W	32.108924	-103.567662	LEA	NEW MEXI CO	NEW MEXI CO	F	NMNM 15091	-7455	15844	10824	Y



U.S. Department of the Interior
BUREAU OF LAND MANAGEMENT

Drilling Plan Data Report

07/20/2021

APD ID: 10400066613

Submission Date: 12/16/2020

Highlighted data
reflects the most
recent changes

Operator Name: BTA OIL PRODUCERS LLC

Well Name: ROJO 7811 22 FEDERAL

Well Number: 73H

[Show Final Text](#)

Well Type: OIL WELL

Well Work Type: Drill

Section 1 - Geologic Formations

Formation ID	Formation Name	Elevation	True Vertical Depth	Measured Depth	Lithologies	Mineral Resources	Producing Formation
1232948	QUATERNARY	3369	0	0	ALLUVIUM	NONE	N
1232949	RUSTLER	2295	1074	1074	ANHYDRITE	NONE	N
1232950	TOP SALT	1795	1574	1574	SALT	NONE	N
1232951	BASE OF SALT	-1375	4744	4744	SALT	NONE	N
1232952	DELAWARE	-1625	4994	4994	LIMESTONE	NATURAL GAS, OIL	N
1232961	BELL CANYON	-1655	5024	5024	SANDSTONE	NATURAL GAS, OIL	N
1232954	CHERRY CANYON	-3025	6394	6394	SANDSTONE	NATURAL GAS, OIL	N
1232955	BRUSHY CANYON	-4195	7564	7564	SANDSTONE	NATURAL GAS, OIL	N
1232956	BONE SPRING LIME	-5785	9154	9154	LIMESTONE	NATURAL GAS, OIL	N
1232970	FIRST BONE SPRING SAND	-6785	10154	10154	SANDSTONE	NATURAL GAS, OIL	N
1233068	BONE SPRING 2ND	-7355	10724	10724	SANDSTONE	NATURAL GAS, OIL	Y

Section 2 - Blowout Prevention

Pressure Rating (PSI): 5M

Rating Depth: 12000

Equipment: The blowout preventer equipment (BOP) shown in Exhibit A will consist of a (5M system) double ram type (5,000 psi WP) preventer and a bag-type (Hydril) preventer (5000 psi WP). Both units will be hydraulically operated and the ram type preventer will be equipped with blind rams on top and 5" drill pipe rams on bottom. The BOPs will be installed on the 13-3/8" surface casing and utilized continuously until total depth is reached. A 2" kill line and 3" choke line will be incorporated in the drilling spool below the ram-type BOP. A remote kill line will be used for the 5M system as per onshore order #2. Other accessory BOP equipment will include a Kelly cock, floor safety valve, choke lines, and choke manifold having a 5,000 psi WP rating. The 5M annular will be tested as per BLM drilling Operations Order No. 2, and will be test to 100% of working pressure.

Requesting Variance? NO

Variance request:

Operator Name: BTA OIL PRODUCERS LLC

Well Name: ROJO 7811 22 FEDERAL

Well Number: 73H

Testing Procedure: Pipe rams will be operated and checked each 24-hour period and each time the drill pipe is out of the hole. These functional tests will be documented on the daily drillers log. All BOPs and associated equipment will be tested as per BLM drilling Operations Order No. 2.

Choke Diagram Attachment:

5M_choke_mannifold_20200917143047.pdf

Choke_Hose___Test_Chart_and_Specs_20190723082742.pdf

BOP Diagram Attachment:

5M_BOP_diagram_20200917143053.pdf

Section 3 - Casing

Casing ID	String Type	Hole Size	Csg Size	Condition	Standard	Tapered String	Top Set MD	Bottom Set MD	Top Set TVD	Bottom Set TVD	Top Set MSL	Bottom Set MSL	Calculated casing length MD	Grade	Weight	Joint Type	Collapse SF	Burst SF	Joint SF Type	Joint SF	Body SF Type	Body SF
1	SURFACE	17.5	13.375	NEW	API	N	0	1070	0	1070	3369	2299	1070	J-55	54.5	ST&C	2.4	5.9	DRY	8.8	DRY	14.6
2	INTERMEDIATE	12.25	9.625	NEW	API	N	0	4983	0	4974	3419	-1605	4983	J-55	40	LT&C	1.9	1.6	DRY	2.6	DRY	3.2
3	PRODUCTION	8.75	5.5	NEW	API	N	0	15844	0	10824	3419	-7455	15844	P-110	17	BUTT	1.4	2	DRY	2.1	DRY	2

Casing Attachments

Casing ID: 1 **String Type:** SURFACE

Inspection Document:

Spec Document:

Tapered String Spec:

Casing Design Assumptions and Worksheet(s):

Rojo_73H_Casing_Assumption_20201211091153.JPG

Operator Name: BTA OIL PRODUCERS LLC

Well Name: ROJO 7811 22 FEDERAL

Well Number: 73H

Casing Attachments

Casing ID: 2 **String Type:** INTERMEDIATE

Inspection Document:

Spec Document:

Tapered String Spec:

Casing Design Assumptions and Worksheet(s):

Rojo_73H_Casing_Assumption_20201211091140.JPG

Casing ID: 3 **String Type:** PRODUCTION

Inspection Document:

Spec Document:

Tapered String Spec:

Casing Design Assumptions and Worksheet(s):

Rojo_73H_Casing_Assumption_20201211091116.JPG

Section 4 - Cement

String Type	Lead/Tail	Stage Tool Depth	Top MD	Bottom MD	Quantity(sx)	Yield	Density	Cu Ft	Excess%	Cement type	Additives
SURFACE	Lead		0	735	595	1.73	13.5	1029.35	100	Class C	2% CaCl2
SURFACE	Tail		735	1070	340	1.35	14.8	459	100	Class C	2% CaCl2
INTERMEDIATE	Lead		0	4425	1305	2.46	12.8	3210.3	100	Class C	0.5% CaCl2
INTERMEDIATE	Tail		4425	4983	200	1.34	14.8	268	25	Class C	1% CaCl2
PRODUCTION	Lead		3983	9910	580	3.9	10.5	2262	60	25% Poz 75% Class C	0.4% Fluid Loss

Operator Name: BTA OIL PRODUCERS LLC

Well Name: ROJO 7811 22 FEDERAL

Well Number: 73H

String Type	Lead/Tail	Stage Tool Depth	Top MD	Bottom MD	Quantity(sx)	Yield	Density	Cu Ft	Excess%	Cement type	Additives
PRODUCTION	Tail		9910	1584 4	1500	1.25	14.4	1875	25	Class H	0.2% LT Retarder

Section 5 - Circulating Medium

Mud System Type: Closed

Will an air or gas system be Used? NO

Description of the equipment for the circulating system in accordance with Onshore Order #2:

Diagram of the equipment for the circulating system in accordance with Onshore Order #2:

Describe what will be on location to control well or mitigate other conditions: Sufficient mud materials to maintain mud properties and meet minimum lost circulation and weight increase requirements will be kept on location at all times.

Describe the mud monitoring system utilized: PVT/Pason/Visual Monitoring

Circulating Medium Table

Top Depth	Bottom Depth	Mud Type	Min Weight (lbs/gal)	Max Weight (lbs/gal)	Density (lbs/cu ft)	Gel Strength (lbs/100 sqft)	PH	Viscosity (CP)	Salinity (ppm)	Filtration (cc)	Additional Characteristics
0	1070	OTHER : FW SPUD	8.3	8.4							
1070	4974	OTHER : FW GEL	9	9.4							
4974	1082 4	OTHER : CUT BRINE	8.7	9.3							

Operator Name: BTA OIL PRODUCERS LLC**Well Name:** ROJO 7811 22 FEDERAL**Well Number:** 73H

Section 6 - Test, Logging, Coring

List of production tests including testing procedures, equipment and safety measures:

Drill Stem Tests will be based on geological sample shows.

List of open and cased hole logs run in the well:

MUD LOG/GEOLOGICAL LITHOLOGY LOG,GAMMA RAY LOG,CEMENT BOND LOG,

Coring operation description for the well:

None planned

Section 7 - Pressure

Anticipated Bottom Hole Pressure: 5291**Anticipated Surface Pressure:** 2909**Anticipated Bottom Hole Temperature(F):** 167**Anticipated abnormal pressures, temperatures, or potential geologic hazards?** NO**Describe:****Contingency Plans geohazards description:****Contingency Plans geohazards attachment:****Hydrogen Sulfide drilling operations plan required?** YES**Hydrogen sulfide drilling operations plan:**

BTA_Oil_Producers_LLC___EMERGENCY_CALL_LIST_20190723161502.pdf

H2S_Equipment_Schematic_20190723161502.pdf

H2S_Plan_20190723161502.pdf

Section 8 - Other Information

Proposed horizontal/directional/multi-lateral plan submission:

Rojo_7811_22_Fed_73H_WM_20201211091441.pdf

QES___Rojo_7811_22_Fed_73H___Geo_Survey_Rpt_20201211091441.pdf

Rojo_73H_Gas_Capture_Plan_20201211091452.pdf

Other proposed operations facets description:

A variance is requested for a Multi Bowl Wellhead. See the attached schematic. *All strings will be kept 1/3 full while running.

Other proposed operations facets attachment:**Other Variance attachment:**

BOP_Break_Testing_Variance_20200917143242.pdf

Multi_Bowl_Diagram_13_38_x_9_58_x_5_12_20200917143315.pdf

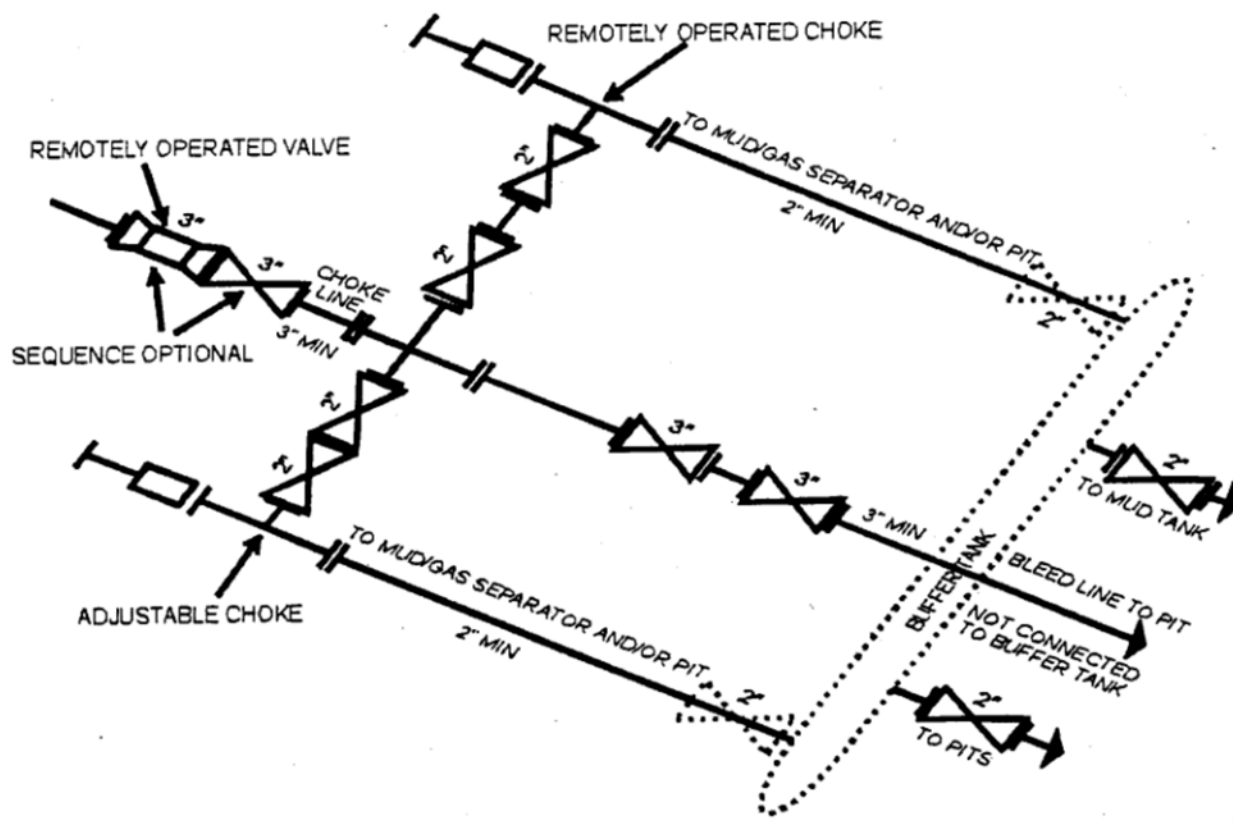

5M CHOKE MANIFOLD EQUIPMENT - CONFIGURATION OF CHOKES MAY VARY

Although not required for any of the choke manifold systems, buffer tanks are sometimes installed downstream of the choke assemblies for the purpose of manifolding the bleed lines together. When buffer tanks are employed, valves shall be installed upstream to isolate a failure or malfunction without interrupting flow control. Though not shown on 2M, 3M, 10M, OR 15M drawings, it would also be applicable to those situations.

[54 FR 39528, Sept. 27, 1989]



Contitech

CONTITECH RUBBER Industrial Kft.	No:QC-DB- 599/ 2014 Page: 16 / 176
-------------------------------------	---------------------------------------

Rig 94

ASSET 24455

QUALITY CONTROL INSPECTION AND TEST CERTIFICATE				CERT. N°: 1592			
PURCHASER: ContiTech Oil & Marine Corp.			P.O. N°: 4500461753				
CONTITECH ORDER N°: 539225		HOSE TYPE: 3" ID		Choke & Kill Hose			
HOSE SERIAL N°: 68547		NOMINAL / ACTUAL LENGTH: 7,62 m / 7,66 m					
W.P. 68,9 MPa	10000 psi	T.P. 103,4 MPa	15000 psi	Duration: 60	min.		
Pressure test with water at ambient temperature							
See attachment. (1 page)							
→	10	Min.					
↑	50	MPa					
COUPLINGS Type		Serial N°		Quality		Heat N°	
3" coupling with		2574	5533	AISI 4130		A1582N H8672	
4 1/16" 10K API Swivel Flange end				AISI 4130		58855	
Hub				AISI 4130		A1199N A1423N	
Not Designed For Well Testing				API Spec 16 C			
Fire Rated				Temperature rate:"B"			
All metal parts are flawless							
WE CERTIFY THAT THE ABOVE HOSE HAS BEEN MANUFACTURED IN ACCORDANCE WITH THE TERMS OF THE ORDER INSPECTED AND PRESSURE TESTED AS ABOVE WITH SATISFACTORY RESULT.							
STATEMENT OF CONFORMITY: We hereby certify that the above items/equipment supplied by us are in conformity with the terms, conditions and specifications of the above Purchaser Order and that these items/equipment were fabricated inspected and tested in accordance with the referenced standards, codes and specifications and meet the relevant acceptance criteria and design requirements.							
Date: 04. September 2014.		Inspector		Quality Control Contitech Rubber Industrial Kft. Quality Control Dept. <i>[Signature]</i>			

Contitech Rubber Industrial Kft. | Budapest 01 19. Ut 5/28 Szeged | H-6701 P.O.Box 132 Szeged, Hungary
 Phone: +36 62 566 737 | Fax: +36 62 566 736 | e-mail: info@hid.contitech.hu | Internet: www.contitech-rubber.hu, www.contitech.hu
 The Court of Csongrad County as Registry Court | Registry Court No. Cg 06 09 002502 | EU VAT No. HU11067206
 Bank: csc: Csongrád Zrt., Budapest | 14220105 26831003

File Name : 000220_68543_68545+547.GEV.....000236_68543_68545+547.GEV
 File Message : 68543_68545_68547
 Device Type : GX70
 Serial No. : SPC606399
 Data Count : 9046
 Print Group :
 Print Range :
 Comment :
 Press-Temp : 2014/09/04 01:53:54.000 - 2014/09/04 04:39:39.000
 Sampling Int. : 1.000 sec
 Start Time : 2014/09/04 01:53:54.000
 Stop Time : 2014/09/04 04:39:39.000

Data No.	Cursor A	Cursor B	Difference
Absolute Time	2014/09/04 02:51:06.000	2014/09/04 03:51:06.000	3600.000
Tag Comment	Value A	Value B	Value B-A
Pressure[bar]	1062.95	1048.57	-14.38
Ambient Temperature[°C]	23.24	23.14	-0.10

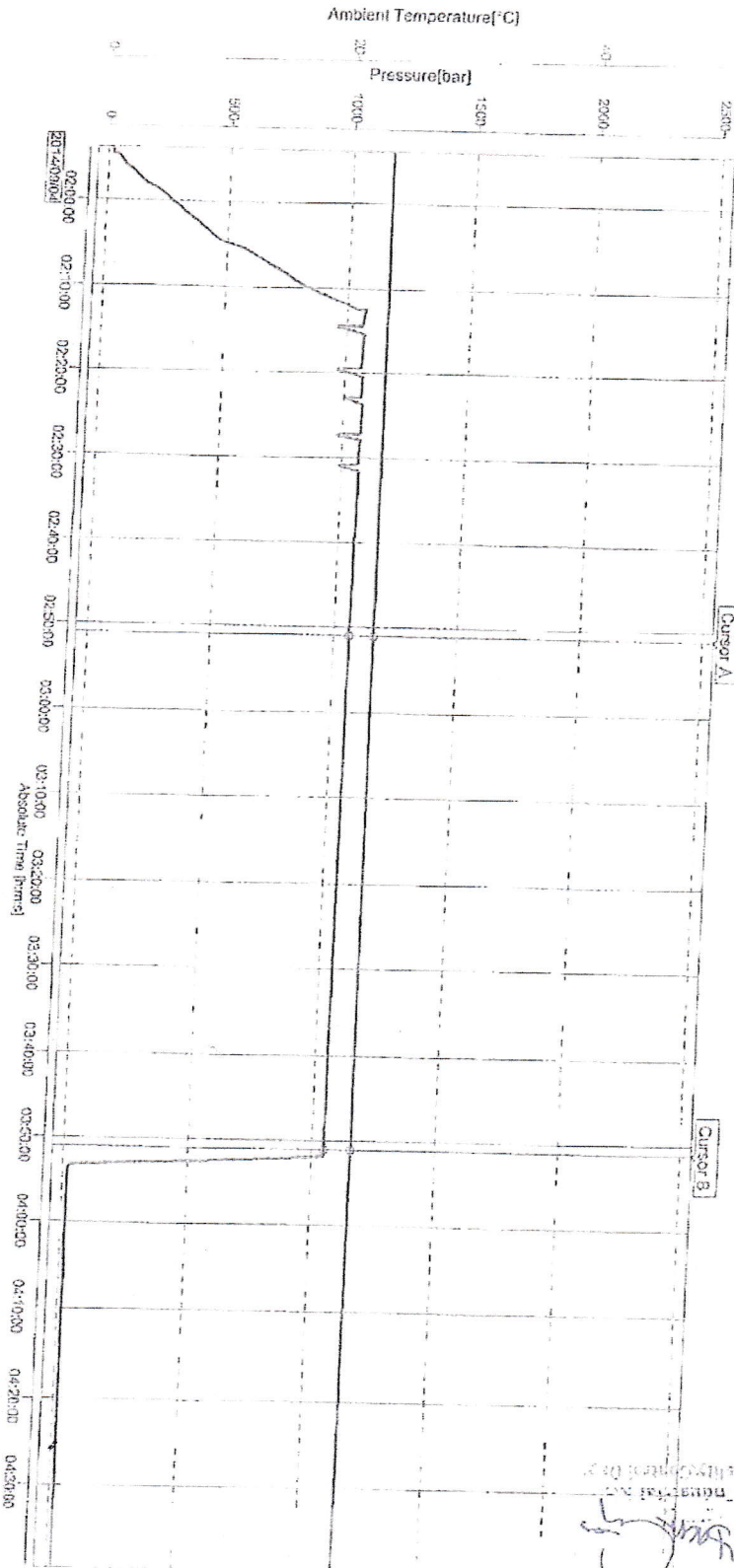

10mm/div

Page: 1 / 1

ATTACHMENT OF QUALITY CONTROL INSPECTION AND TEST CERTIFICATE No: 1588, 1590, 1592

13-5/8" 5,000 PSI BOP

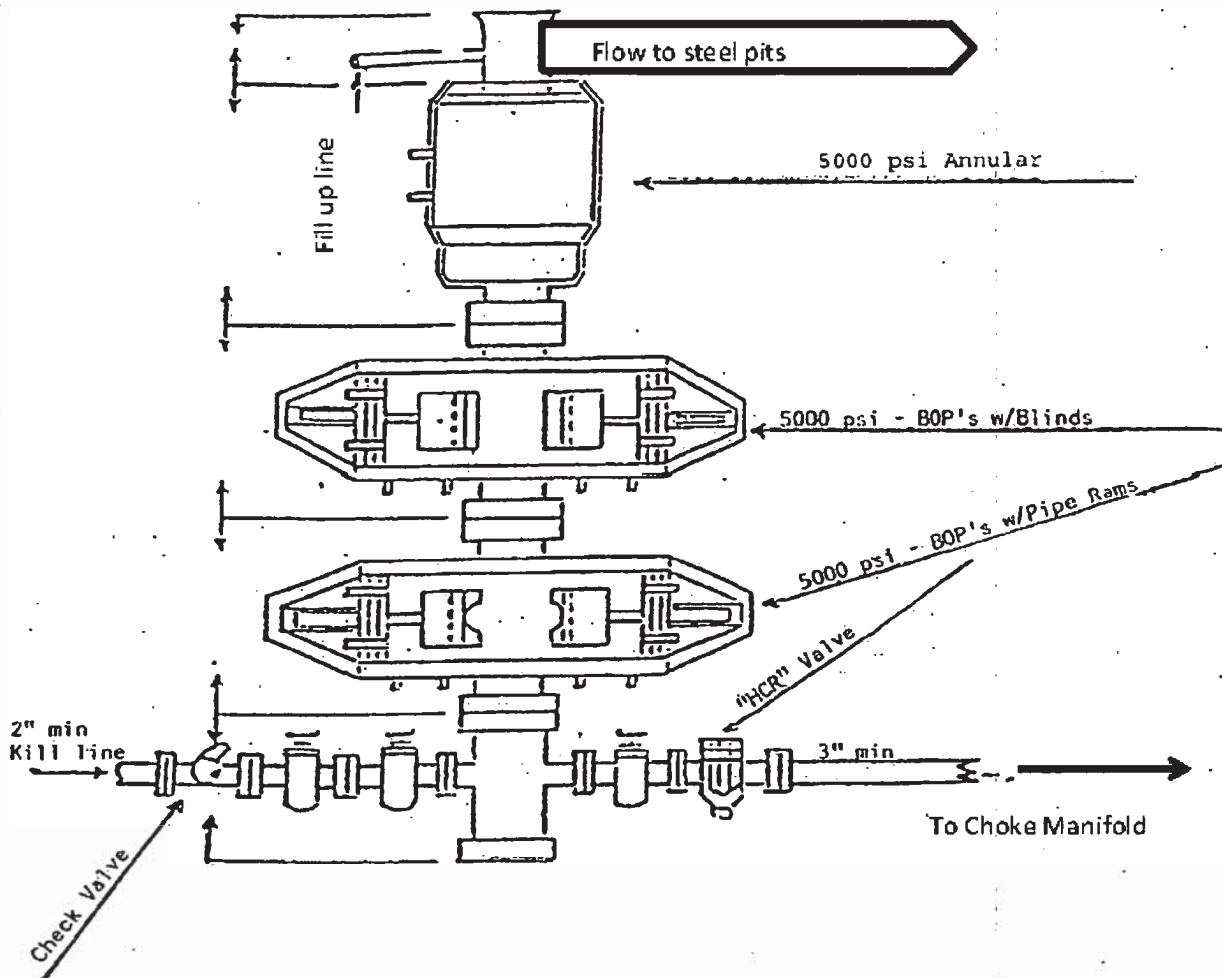



BTA Oil Producers, LLC
 104 S Pecos
 Midland, TX 79701

WELL: Rojo 7811 22 #73H
 TVD: 10824
 MD: 15844

DRILLING PLAN

Casing Program

Hole Size	Csg. Size	From (MD)	To (MD)	From (TVD)	To (TVD)	Tapered String	Weight (lbs)	Grade	Conn.	Collapse	Burst	Body Tension	Joint Tension	Dry/Buoyant	Mud Weight (ppg)
17 1/2	13 3/8	0	1070	0	1070	No	54.5	J-55	STC	2.4	5.9	14.6	8.8	Dry	8.3
12 1/4	9 5/8	0	4983	0	4974	No	40	J-55	LTC	1.9	1.6	3.2	2.6	Dry	9.4
8 3/4	5.5	0	15844	0	10824	No	17	F110	Buttress	1.4	2.0	2.0	2.1	Dry	9.4

EMERGENCY CALL LIST

	<u>OFFICE</u>	<u>MOBILE</u>
BTA Oil Producers LLC OFFICE	432-682-3753	
BEN GRIMES, Operations	432-682-3753	432-559-4309
NICK EATON, Drilling	432-682-3753	432-260-7841
TRACE WOHLFAHRT, Completions	432-682-3753	

EMERGENCY RESPONSE NUMBERS

	<u>OFFICE</u>
STATE POLICE	575-748-9718
EDDY COUNTY SHERIFF	575-746-2701
EMERGENCY MEDICAL SERVICES (AMBULANCE)	911 or 575-746-2701
EDDY COUNTY EMERGENCY MANAGEMENT (HARRY BURGESS)	575-887-9511
STATE EMERGENCY RESPONSE CENTER (SERC)	575-476-9620
CARLSBAD POLICE DEPARTMENT	575-885-2111
CARLSBAD FIRE DEPARTMENT	575-885-3125
NEW MEXICO OIL CONSERVATION DIVISION	575-748-1283
INDIAN FIRE & SAFETY	800-530-8693
HALLIBURTON SERVICES	800-844-8451

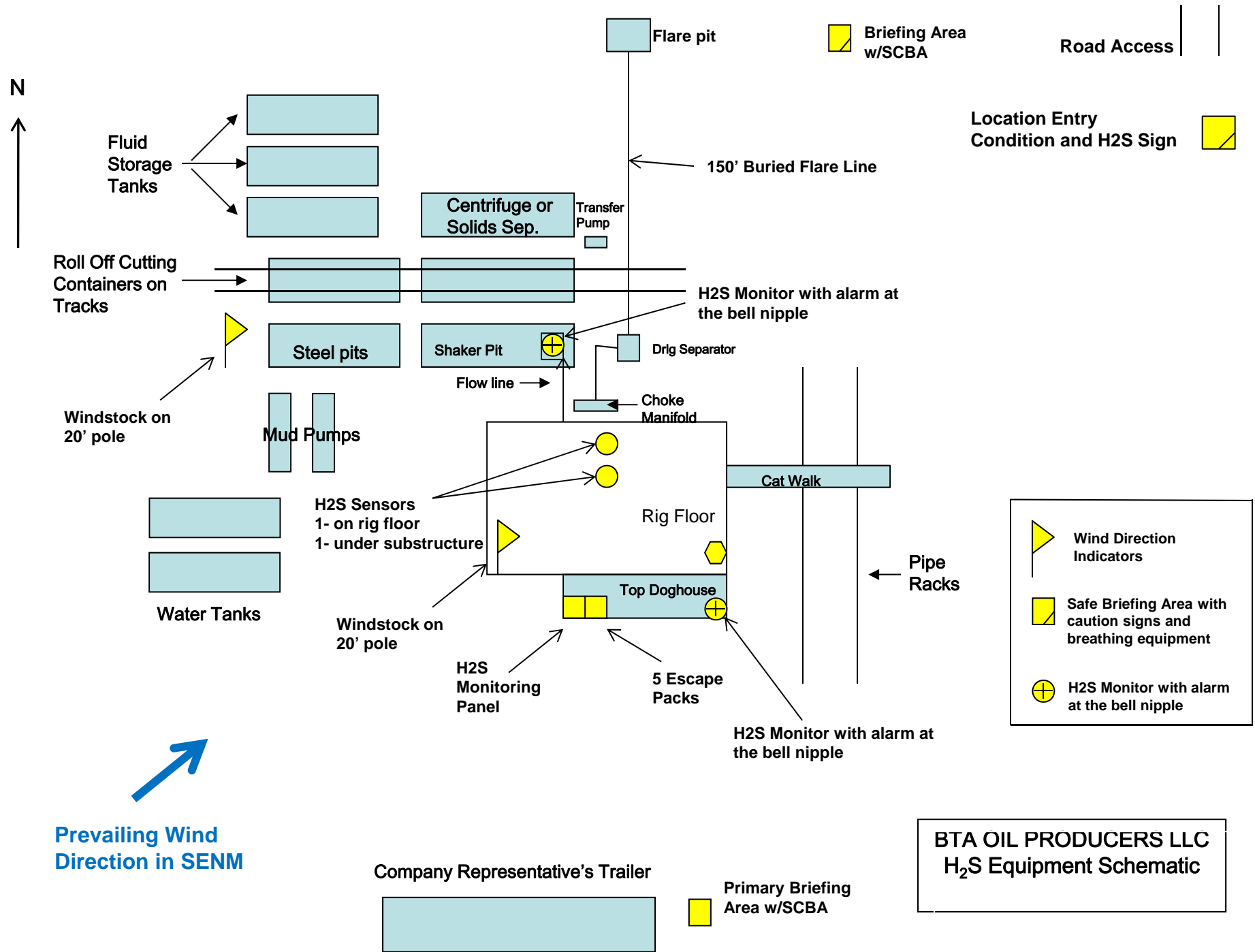

**BTA OIL PRODUCERS LLC
H₂S Equipment Schematic**

BTA OIL PRODUCERS LLC**HYDROGEN SULFIDE DRILLING OPERATIONS PLAN****1. HYDROGEN SULFIDE TRAINING**

All personnel, whether regularly assigned, contracted, or employed on an unscheduled basis, will receive training from a qualified instructor in the following areas prior to commencing drilling operations on this well:

- a. The hazards and characteristics of hydrogen sulfide (H₂S).
- b. The proper use and maintenance of personal protective equipment and life support systems.
- c. The proper use of H₂S detectors, alarms, warning systems, briefing areas, evacuation procedures, and prevailing winds.
- d. The proper techniques for first aid and rescue procedures.

In addition, supervisory personnel will be trained in the following areas:

- a. The effects of H₂S on metal components. If high tensile tubulars are to be used, personnel will be trained in their special maintenance requirements.
- b. Corrective action and shut-in procedures when drilling or reworking a well and blowout prevention and well control procedures.
- c. The contents and requirements of the H₂S Drilling Operations Plan and the Public Protection Plan.

There will be an initial training session just prior to encountering a known or probable H₂S zone (within 3 days or 500 feet) and weekly H₂S and well control drills for all personnel in each crew. The initial training session shall include a review of the site specific H₂S Drilling Operations Plan and the Public Protection Plan. This plan shall be available at the well site. All personnel will be required to carry documentation that they have received the proper training.

2. H₂S SAFETY EQUIPMENT AND SYSTEMS

Note: All H₂S safety equipment and systems will be installed, tested, and operational when drilling reaches a depth of 500 feet above, or three days prior to penetrating the first zone containing or reasonably expected to contain H₂S. If H₂S greater than 100 ppm is encountered in the gas stream we will shut in and install H₂S equipment.

- a. Well Control Equipment:
 - Flare line.
 - Choke manifold with remotely operated choke.
 - Blind rams and pipe rams to accommodate all pipe sizes with properly sized closing unit.
 - Auxiliary equipment to include: annular preventer, mud-gas separator, rotating head.
- b. Protective equipment for essential personnel:
 - Mark II Surviveair 30-minute units located in the dog house and at briefing areas.
- c. H₂S detection and monitoring equipment:

- 2 - portable H2S monitor positioned on location for best coverage and response. These units have warning lights and audible sirens when H2S levels of 20 ppm are reached.
- d. Visual warning systems:
Caution/Danger signs shall be posted on roads providing direct access to location. Signs will be painted a high visibility yellow with black lettering of sufficient size to be readable at a reasonable distance from the immediate location. Bilingual signs will be used, when appropriate. See example attached.
 - e. Mud Program:
The mud program has been designed to minimize the volume of H2S circulated to the surface.
 - f. Metallurgy:
All drill strings, casings, tubing, wellhead, blowout preventers, drilling spool, kill lines, choke manifold and lines, and valves shall be suitable for H2S service.
 - g. Communication:
Company vehicles equipped with cellular telephone.

W A R N I N G

**YOU ARE ENTERING AN H₂S AREA
AUTHORIZED PERSONNEL ONLY**

- 1. BEARDS OR CONTACT LENSES NOT ALLOWED**
- 2. HARD HATS REQUIRED**
- 3. SMOKING IN DESIGNATED AREAS ONLY**
- 4. BE WIND CONSCIOUS AT ALL TIMES**
- 5. CK WITH BTA OIL PRODUCERS LLC FOREMAN AT MAIN OFFICE**

BTA OIL PRODUCERS LLC

1-432-682-3753

Company Name: BTA Oil Producers, LLC
 Rojo 7811 22 Fed #73H
 Lea County, NM (NAD 83)
 Rig: Patterson
 Created By: Shane Robbins
 Date: 10/28/2020

Rojo 7811 22 Fed #73H
 Lea County, NM (NAD 83)
 Q200*** & WT-200***
 Design #1

PROJECT DETAILS: Lea County, NM (NAD 83)

Geodetic System: US State Plane 1983
 Datum: North American Datum 1983
 Ellipsoid: GRS 1980
 Zone: New Mexico Eastern Zone
 System Datum: Mean Sea Level



Azimuths to Grid North

Magnetic North: 6.08°
 Magnetic Field
 Strength: 47642.7nT
 Dip Angle: 59.70°
 Date: 10/28/2020
 Model: HDGM2020

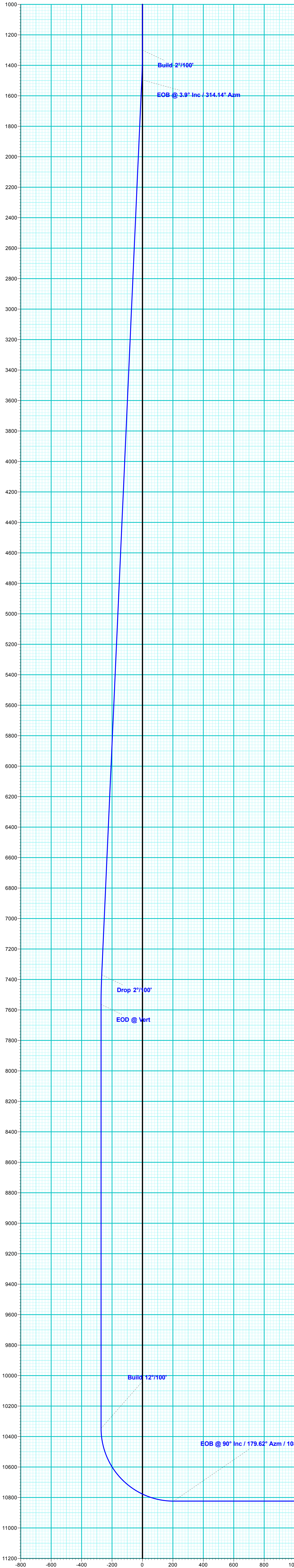
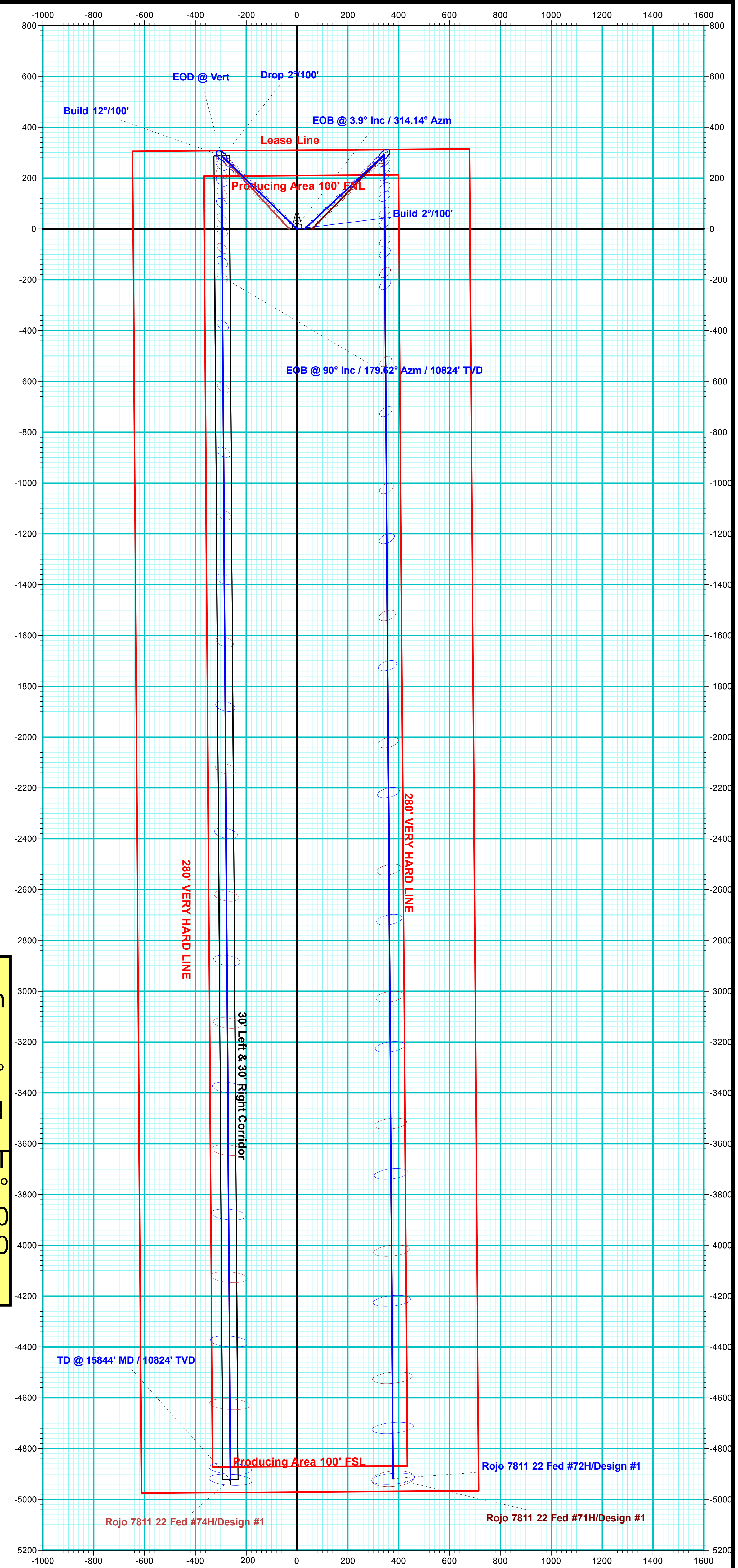

WELL DETAILS: Rojo 7811 22 Fed #73H

				3369.0	
+N/-S	+E/-W	Northing	Easting	Latitude	Longitude
0.0	0.0	409127.60	778670.80	32° 7' 20.819 N	103° 34' 0.127 W

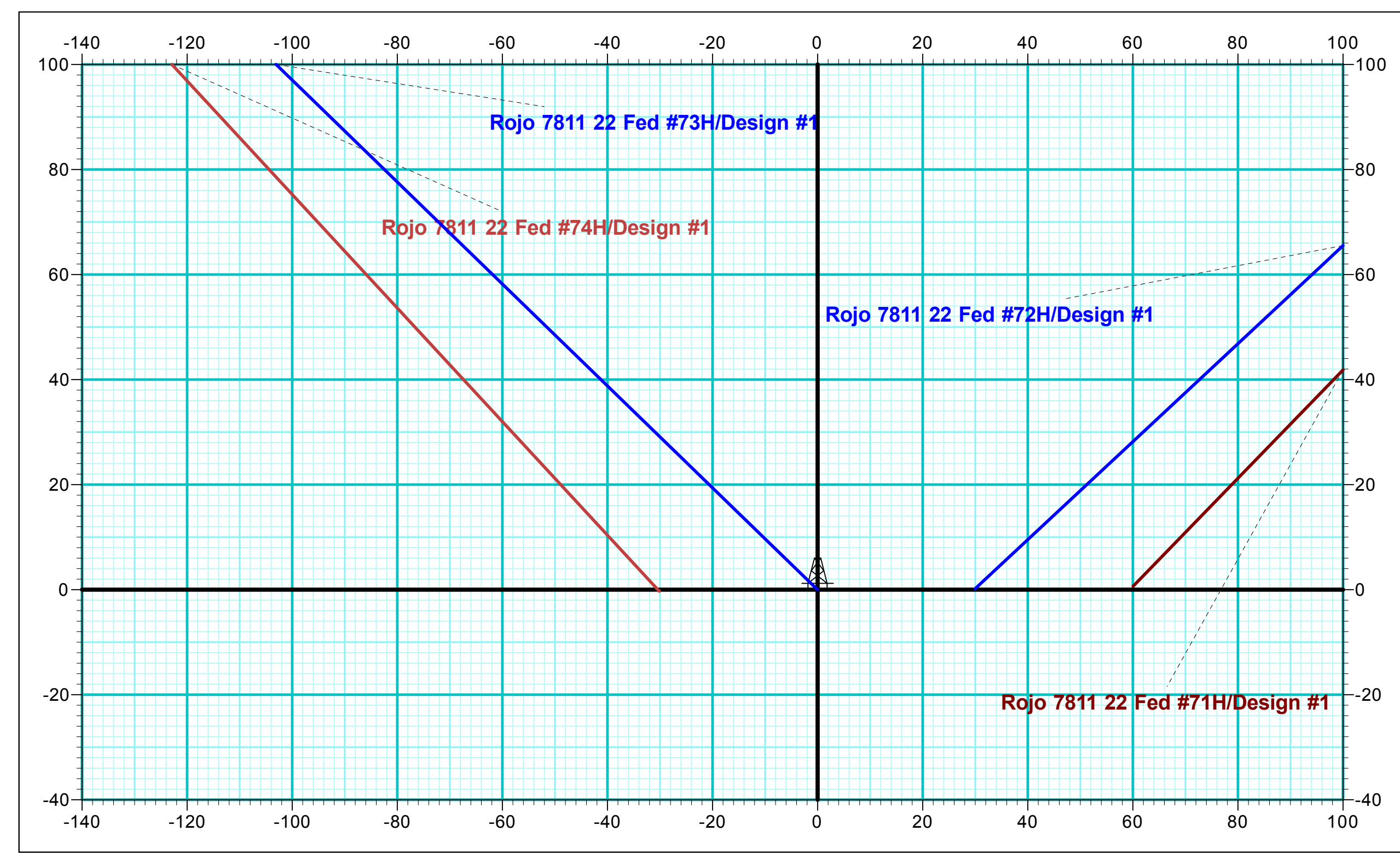

ANNOTATIONS

MD	Inc	Azi	TVD	+N/-S	+E/-W	Vsect	Departure	Annotation
1300.0	0.00	0.00	1300.0	0.0	0.0	0.0	0.0	Build 2°/100°
1495.0	3.90	314.14	1494.9	4.6	-4.8	-4.4	6.6	EOB @ 3.9° Inc / 314.14° Azm
7382.9	3.90	314.14	7369.1	283.6	-292.2	-267.6	407.2	Drop 2°/100°
7577.9	0.00	0.00	7564.0	288.2	-296.9	-272.0	413.8	EOD @ Vert
10360.4	0.00	0.00	10346.5	288.2	-296.9	-272.0	413.8	Build 12°/100°
11110.4	90.00	179.62	10824.0	-189.3	-293.8	204.6	891.3	EOB @ 90° Inc / 179.62° Azm / 10824' TVD
15843.8	90.00	179.62	10824.0	-4922.5	-262.2	4929.5	5624.6	TD @ 15844' MD / 10824' TVD

Vertical Section at 183.05° (200 usft/in)



BTA Oil Producers, LLC

Lea County, NM (NAD 83)

Sec 22, T25-S, R33-E

Rojo 7811 22 Fed #73H

Wellbore #1

Plan: Design #1

Survey Report - Geographic

11 November, 2020





QES
Survey Report - Geographic



Company:	BTA Oil Producers, LLC	Local Co-ordinate Reference:	Well Rojo 7811 22 Fed #73H
Project:	Lea County, NM (NAD 83)	TVD Reference:	WELL @ 3394.0usft (Patterson)
Site:	Sec 22, T25-S, R33-E	MD Reference:	WELL @ 3394.0usft (Patterson)
Well:	Rojo 7811 22 Fed #73H	North Reference:	Grid
Wellbore:	Wellbore #1	Survey Calculation Method:	Minimum Curvature
Design:	Design #1	Database:	EDM 5000.1 Single User Db

Project	Lea County, NM (NAD 83)		
Map System:	US State Plane 1983	System Datum:	Mean Sea Level
Geo Datum:	North American Datum 1983		
Map Zone:	New Mexico Eastern Zone		

Site	Sec 22, T25-S, R33-E				
Site Position:		Northing:	409,243.40 usft	Latitude:	32.122719
From:	Map	Easting:	781,148.30 usft	Longitude:	-103.558697
Position Uncertainty:	0.0 usft	Slot Radius:	13-3/16 "	Grid Convergence:	0.41 °

Well	Rojo 7811 22 Fed #73H					
Well Position	+N/-S	0.0 usft	Northing:	409,127.60 usft	Latitude:	32.122450
	+E/-W	0.0 usft	Easting:	778,670.80 usft	Longitude:	-103.566702
Position Uncertainty		0.0 usft	Wellhead Elevation:	usft	Ground Level:	3,369.0 usft

Wellbore	Wellbore #1				
Magnetics	Model Name	Sample Date	Declination (°)	Dip Angle (°)	Field Strength (nT)
	HDGM2020	10/28/2020	6.48	59.70	47,642.70000000

Design	Design #1				
Audit Notes:					
Version:	Phase:	PLAN	Tie On Depth:	0.0	
Vertical Section:	Depth From (TVD) (usft)	+N/-S (usft)	+E/-W (usft)	Direction (°)	
	0.0	0.0	0.0	183.05	

Survey Tool Program	Date	10/28/2020			
From (usft)	To (usft)	Survey (Wellbore)	Tool Name	Description	
0.0	15,843.8	Design #1 (Wellbore #1)	MWD	OWSG MWD - Standard	

Planned Survey										
Measured Depth (usft)	Inclination (°)	Azimuth (°)	Vertical Depth (usft)	+N/-S (usft)	+E/-W (usft)	Map Northing (usft)	Map Easting (usft)	Latitude	Longitude	
0.0	0.00	0.00	0.0	0.0	0.0	409,127.60	778,670.80	32.122450	-103.566702	
100.0	0.00	0.00	100.0	0.0	0.0	409,127.60	778,670.80	32.122450	-103.566702	
200.0	0.00	0.00	200.0	0.0	0.0	409,127.60	778,670.80	32.122450	-103.566702	
300.0	0.00	0.00	300.0	0.0	0.0	409,127.60	778,670.80	32.122450	-103.566702	
400.0	0.00	0.00	400.0	0.0	0.0	409,127.60	778,670.80	32.122450	-103.566702	
500.0	0.00	0.00	500.0	0.0	0.0	409,127.60	778,670.80	32.122450	-103.566702	
600.0	0.00	0.00	600.0	0.0	0.0	409,127.60	778,670.80	32.122450	-103.566702	
700.0	0.00	0.00	700.0	0.0	0.0	409,127.60	778,670.80	32.122450	-103.566702	
800.0	0.00	0.00	800.0	0.0	0.0	409,127.60	778,670.80	32.122450	-103.566702	
900.0	0.00	0.00	900.0	0.0	0.0	409,127.60	778,670.80	32.122450	-103.566702	
1,000.0	0.00	0.00	1,000.0	0.0	0.0	409,127.60	778,670.80	32.122450	-103.566702	
1,100.0	0.00	0.00	1,100.0	0.0	0.0	409,127.60	778,670.80	32.122450	-103.566702	



QES
Survey Report - Geographic



Company:	BTA Oil Producers, LLC	Local Co-ordinate Reference:	Well Rojo 7811 22 Fed #73H
Project:	Lea County, NM (NAD 83)	TVD Reference:	WELL @ 3394.0usft (Patterson)
Site:	Sec 22, T25-S, R33-E	MD Reference:	WELL @ 3394.0usft (Patterson)
Well:	Rojo 7811 22 Fed #73H	North Reference:	Grid
Wellbore:	Wellbore #1	Survey Calculation Method:	Minimum Curvature
Design:	Design #1	Database:	EDM 5000.1 Single User Db

Planned Survey										
Measured Depth (usft)	Inclination (°)	Azimuth (°)	Vertical Depth (usft)	+N/-S (usft)	+E/-W (usft)	Map Northing (usft)	Map Easting (usft)	Latitude	Longitude	
1,200.0	0.00	0.00	1,200.0	0.0	0.0	409,127.60	778,670.80	32.122450	-103.566702	
1,300.0	0.00	0.00	1,300.0	0.0	0.0	409,127.60	778,670.80	32.122450	-103.566702	
Build 2°/100'										
1,400.0	2.00	314.14	1,400.0	1.2	-1.3	409,128.81	778,669.55	32.122453	-103.566706	
1,495.0	3.90	314.14	1,494.9	4.6	-4.8	409,132.22	778,666.04	32.122463	-103.566718	
EOB @ 3.9° Inc / 314.14° Azm										
1,500.0	3.90	314.14	1,499.8	4.9	-5.0	409,132.46	778,665.79	32.122463	-103.566718	
1,600.0	3.90	314.14	1,599.6	9.6	-9.9	409,137.19	778,660.91	32.122476	-103.566734	
1,700.0	3.90	314.14	1,699.4	14.3	-14.8	409,141.93	778,656.03	32.122490	-103.566750	
1,800.0	3.90	314.14	1,799.1	19.1	-19.6	409,146.67	778,651.15	32.122503	-103.566765	
1,900.0	3.90	314.14	1,898.9	23.8	-24.5	409,151.41	778,646.27	32.122516	-103.566781	
2,000.0	3.90	314.14	1,998.7	28.5	-29.4	409,156.14	778,641.39	32.122529	-103.566797	
2,100.0	3.90	314.14	2,098.4	33.3	-34.3	409,160.88	778,636.50	32.122542	-103.566812	
2,200.0	3.90	314.14	2,198.2	38.0	-39.2	409,165.62	778,631.62	32.122555	-103.566828	
2,300.0	3.90	314.14	2,298.0	42.8	-44.1	409,170.36	778,626.74	32.122568	-103.566844	
2,400.0	3.90	314.14	2,397.8	47.5	-48.9	409,175.10	778,621.86	32.122581	-103.566859	
2,500.0	3.90	314.14	2,497.5	52.2	-53.8	409,179.83	778,616.98	32.122595	-103.566875	
2,600.0	3.90	314.14	2,597.3	57.0	-58.7	409,184.57	778,612.10	32.122608	-103.566891	
2,700.0	3.90	314.14	2,697.1	61.7	-63.6	409,189.31	778,607.22	32.122621	-103.566906	
2,800.0	3.90	314.14	2,796.8	66.4	-68.5	409,194.05	778,602.33	32.122634	-103.566922	
2,900.0	3.90	314.14	2,896.6	71.2	-73.3	409,198.78	778,597.45	32.122647	-103.566937	
3,000.0	3.90	314.14	2,996.4	75.9	-78.2	409,203.52	778,592.57	32.122660	-103.566953	
3,100.0	3.90	314.14	3,096.1	80.7	-83.1	409,208.26	778,587.69	32.122673	-103.566969	
3,200.0	3.90	314.14	3,195.9	85.4	-88.0	409,213.00	778,582.81	32.122686	-103.566984	
3,300.0	3.90	314.14	3,295.7	90.1	-92.9	409,217.73	778,577.93	32.122699	-103.567000	
3,400.0	3.90	314.14	3,395.4	94.9	-97.8	409,222.47	778,573.05	32.122713	-103.567016	
3,500.0	3.90	314.14	3,495.2	99.6	-102.6	409,227.21	778,568.17	32.122726	-103.567031	
3,600.0	3.90	314.14	3,595.0	104.3	-107.5	409,231.95	778,563.28	32.122739	-103.567047	
3,700.0	3.90	314.14	3,694.7	109.1	-112.4	409,236.69	778,558.40	32.122752	-103.567063	
3,800.0	3.90	314.14	3,794.5	113.8	-117.3	409,241.42	778,553.52	32.122765	-103.567078	
3,900.0	3.90	314.14	3,894.3	118.6	-122.2	409,246.16	778,548.64	32.122778	-103.567094	
4,000.0	3.90	314.14	3,994.0	123.3	-127.0	409,250.90	778,543.76	32.122791	-103.567110	
4,100.0	3.90	314.14	4,093.8	128.0	-131.9	409,255.64	778,538.88	32.122804	-103.567125	
4,200.0	3.90	314.14	4,193.6	132.8	-136.8	409,260.37	778,534.00	32.122818	-103.567141	
4,300.0	3.90	314.14	4,293.4	137.5	-141.7	409,265.11	778,529.11	32.122831	-103.567157	
4,400.0	3.90	314.14	4,393.1	142.2	-146.6	409,269.85	778,524.23	32.122844	-103.567172	
4,500.0	3.90	314.14	4,492.9	147.0	-151.4	409,274.59	778,519.35	32.122857	-103.567188	
4,600.0	3.90	314.14	4,592.7	151.7	-156.3	409,279.32	778,514.47	32.122870	-103.567204	
4,700.0	3.90	314.14	4,692.4	156.5	-161.2	409,284.06	778,509.59	32.122883	-103.567219	
4,800.0	3.90	314.14	4,792.2	161.2	-166.1	409,288.80	778,504.71	32.122896	-103.567235	
4,900.0	3.90	314.14	4,892.0	165.9	-171.0	409,293.54	778,499.83	32.122909	-103.567251	
5,000.0	3.90	314.14	4,991.7	170.7	-175.9	409,298.27	778,494.94	32.122922	-103.567266	
5,100.0	3.90	314.14	5,091.5	175.4	-180.7	409,303.01	778,490.06	32.122936	-103.567282	
5,200.0	3.90	314.14	5,191.3	180.2	-185.6	409,307.75	778,485.18	32.122949	-103.567298	
5,300.0	3.90	314.14	5,291.0	184.9	-190.5	409,312.49	778,480.30	32.122962	-103.567313	
5,400.0	3.90	314.14	5,390.8	189.6	-195.4	409,317.23	778,475.42	32.122975	-103.567329	
5,500.0	3.90	314.14	5,490.6	194.4	-200.3	409,321.96	778,470.54	32.122988	-103.567345	
5,600.0	3.90	314.14	5,590.3	199.1	-205.1	409,326.70	778,465.66	32.123001	-103.567360	
5,700.0	3.90	314.14	5,690.1	203.8	-210.0	409,331.44	778,460.78	32.123014	-103.567376	
5,800.0	3.90	314.14	5,789.9	208.6	-214.9	409,336.18	778,455.89	32.123027	-103.567392	
5,900.0	3.90	314.14	5,889.6	213.3	-219.8	409,340.91	778,451.01	32.123041	-103.567407	
6,000.0	3.90	314.14	5,989.4	218.1	-224.7	409,345.65	778,446.13	32.123054	-103.567423	
6,100.0	3.90	314.14	6,089.2	222.8	-229.5	409,350.39	778,441.25	32.123067	-103.567439	
6,200.0	3.90	314.14	6,189.0	227.5	-234.4	409,355.13	778,436.37	32.123080	-103.567454	
6,300.0	3.90	314.14	6,288.7	232.3	-239.3	409,359.86	778,431.49	32.123093	-103.567470	



QES
Survey Report - Geographic



Company:	BTA Oil Producers, LLC	Local Co-ordinate Reference:	Well Rojo 7811 22 Fed #73H
Project:	Lea County, NM (NAD 83)	TVD Reference:	WELL @ 3394.0usft (Patterson)
Site:	Sec 22, T25-S, R33-E	MD Reference:	WELL @ 3394.0usft (Patterson)
Well:	Rojo 7811 22 Fed #73H	North Reference:	Grid
Wellbore:	Wellbore #1	Survey Calculation Method:	Minimum Curvature
Design:	Design #1	Database:	EDM 5000.1 Single User Db

Planned Survey										
Measured Depth (usft)	Inclination (°)	Azimuth (°)	Vertical Depth (usft)	+N/-S (usft)	+E/-W (usft)	Map Northing (usft)	Map Easting (usft)	Latitude	Longitude	
6,400.0	3.90	314.14	6,388.5	237.0	-244.2	409,364.60	778,426.61	32.123106	-103.567486	
6,500.0	3.90	314.14	6,488.3	241.7	-249.1	409,369.34	778,421.72	32.123119	-103.567501	
6,600.0	3.90	314.14	6,588.0	246.5	-254.0	409,374.08	778,416.84	32.123132	-103.567517	
6,700.0	3.90	314.14	6,687.8	251.2	-258.8	409,378.82	778,411.96	32.123145	-103.567532	
6,800.0	3.90	314.14	6,787.6	256.0	-263.7	409,383.55	778,407.08	32.123159	-103.567548	
6,900.0	3.90	314.14	6,887.3	260.7	-268.6	409,388.29	778,402.20	32.123172	-103.567564	
7,000.0	3.90	314.14	6,987.1	265.4	-273.5	409,393.03	778,397.32	32.123185	-103.567579	
7,100.0	3.90	314.14	7,086.9	270.2	-278.4	409,397.77	778,392.44	32.123198	-103.567595	
7,200.0	3.90	314.14	7,186.6	274.9	-283.2	409,402.50	778,387.55	32.123211	-103.567611	
7,300.0	3.90	314.14	7,286.4	279.6	-288.1	409,407.24	778,382.67	32.123224	-103.567626	
7,382.9	3.90	314.14	7,369.1	283.6	-292.2	409,411.17	778,378.63	32.123235	-103.567639	
Drop 2°/100'										
7,400.0	3.56	314.14	7,386.2	284.3	-293.0	409,411.94	778,377.83	32.123237	-103.567642	
7,500.0	1.56	314.14	7,486.1	287.5	-296.2	409,415.05	778,374.62	32.123246	-103.567652	
7,577.9	0.00	0.00	7,564.0	288.2	-296.9	409,415.79	778,373.86	32.123248	-103.567655	
EOD @ Vert										
7,600.0	0.00	0.00	7,586.1	288.2	-296.9	409,415.79	778,373.86	32.123248	-103.567655	
7,700.0	0.00	0.00	7,686.1	288.2	-296.9	409,415.79	778,373.86	32.123248	-103.567655	
7,800.0	0.00	0.00	7,786.1	288.2	-296.9	409,415.79	778,373.86	32.123248	-103.567655	
7,900.0	0.00	0.00	7,886.1	288.2	-296.9	409,415.79	778,373.86	32.123248	-103.567655	
8,000.0	0.00	0.00	7,986.1	288.2	-296.9	409,415.79	778,373.86	32.123248	-103.567655	
8,100.0	0.00	0.00	8,086.1	288.2	-296.9	409,415.79	778,373.86	32.123248	-103.567655	
8,200.0	0.00	0.00	8,186.1	288.2	-296.9	409,415.79	778,373.86	32.123248	-103.567655	
8,300.0	0.00	0.00	8,286.1	288.2	-296.9	409,415.79	778,373.86	32.123248	-103.567655	
8,400.0	0.00	0.00	8,386.1	288.2	-296.9	409,415.79	778,373.86	32.123248	-103.567655	
8,500.0	0.00	0.00	8,486.1	288.2	-296.9	409,415.79	778,373.86	32.123248	-103.567655	
8,600.0	0.00	0.00	8,586.1	288.2	-296.9	409,415.79	778,373.86	32.123248	-103.567655	
8,700.0	0.00	0.00	8,686.1	288.2	-296.9	409,415.79	778,373.86	32.123248	-103.567655	
8,800.0	0.00	0.00	8,786.1	288.2	-296.9	409,415.79	778,373.86	32.123248	-103.567655	
8,900.0	0.00	0.00	8,886.1	288.2	-296.9	409,415.79	778,373.86	32.123248	-103.567655	
9,000.0	0.00	0.00	8,986.1	288.2	-296.9	409,415.79	778,373.86	32.123248	-103.567655	
9,100.0	0.00	0.00	9,086.1	288.2	-296.9	409,415.79	778,373.86	32.123248	-103.567655	
9,200.0	0.00	0.00	9,186.1	288.2	-296.9	409,415.79	778,373.86	32.123248	-103.567655	
9,300.0	0.00	0.00	9,286.1	288.2	-296.9	409,415.79	778,373.86	32.123248	-103.567655	
9,400.0	0.00	0.00	9,386.1	288.2	-296.9	409,415.79	778,373.86	32.123248	-103.567655	
9,500.0	0.00	0.00	9,486.1	288.2	-296.9	409,415.79	778,373.86	32.123248	-103.567655	
9,600.0	0.00	0.00	9,586.1	288.2	-296.9	409,415.79	778,373.86	32.123248	-103.567655	
9,700.0	0.00	0.00	9,686.1	288.2	-296.9	409,415.79	778,373.86	32.123248	-103.567655	
9,800.0	0.00	0.00	9,786.1	288.2	-296.9	409,415.79	778,373.86	32.123248	-103.567655	
9,900.0	0.00	0.00	9,886.1	288.2	-296.9	409,415.79	778,373.86	32.123248	-103.567655	
10,000.0	0.00	0.00	9,986.1	288.2	-296.9	409,415.79	778,373.86	32.123248	-103.567655	
10,100.0	0.00	0.00	10,086.1	288.2	-296.9	409,415.79	778,373.86	32.123248	-103.567655	
10,200.0	0.00	0.00	10,186.1	288.2	-296.9	409,415.79	778,373.86	32.123248	-103.567655	
10,300.0	0.00	0.00	10,286.1	288.2	-296.9	409,415.79	778,373.86	32.123248	-103.567655	
10,360.4	0.00	0.00	10,346.5	288.2	-296.9	409,415.79	778,373.86	32.123248	-103.567655	
Build 12°/100'										
10,375.0	1.75	179.62	10,361.1	288.0	-296.9	409,415.57	778,373.87	32.123247	-103.567655	
10,400.0	4.75	179.62	10,386.0	286.6	-296.9	409,414.15	778,373.88	32.123243	-103.567655	
10,425.0	7.75	179.62	10,410.9	283.8	-296.9	409,411.43	778,373.89	32.123236	-103.567655	
10,450.0	10.75	179.62	10,435.5	279.8	-296.9	409,407.42	778,373.92	32.123225	-103.567655	
10,475.0	13.75	179.62	10,460.0	274.5	-296.8	409,402.11	778,373.96	32.123210	-103.567655	
10,500.0	16.75	179.62	10,484.1	267.9	-296.8	409,395.54	778,374.00	32.123192	-103.567655	
10,525.0	19.75	179.62	10,507.8	260.1	-296.7	409,387.71	778,374.05	32.123171	-103.567655	
10,550.0	22.75	179.62	10,531.1	251.1	-296.7	409,378.65	778,374.11	32.123146	-103.567655	
10,575.0	25.75	179.62	10,553.9	240.8	-296.6	409,368.39	778,374.18	32.123118	-103.567655	



QES
Survey Report - Geographic



Company:	BTA Oil Producers, LLC	Local Co-ordinate Reference:	Well Rojo 7811 22 Fed #73H
Project:	Lea County, NM (NAD 83)	TVD Reference:	WELL @ 3394.0usft (Patterson)
Site:	Sec 22, T25-S, R33-E	MD Reference:	WELL @ 3394.0usft (Patterson)
Well:	Rojo 7811 22 Fed #73H	North Reference:	Grid
Wellbore:	Wellbore #1	Survey Calculation Method:	Minimum Curvature
Design:	Design #1	Database:	EDM 5000.1 Single User Db

Planned Survey

Measured Depth (usft)	Inclination (°)	Azimuth (°)	Vertical Depth (usft)	+N/-S (usft)	+E/-W (usft)	Map Northing (usft)	Map Easting (usft)	Latitude	Longitude
10,600.0	28.75	179.62	10,576.1	229.3	-296.5	409,356.94	778,374.26	32.123086	-103.567655
10,625.0	31.75	179.62	10,597.7	216.8	-296.5	409,344.35	778,374.34	32.123051	-103.567655
10,650.0	34.75	179.62	10,618.6	203.0	-296.4	409,330.65	778,374.43	32.123014	-103.567655
10,675.0	37.75	179.62	10,638.8	188.3	-296.3	409,315.87	778,374.53	32.122973	-103.567655
10,700.0	40.75	179.62	10,658.2	172.5	-296.2	409,300.05	778,374.64	32.122930	-103.567655
10,725.0	43.75	179.62	10,676.7	155.6	-296.0	409,283.25	778,374.75	32.122884	-103.567655
10,750.0	46.75	179.62	10,694.3	137.9	-295.9	409,265.50	778,374.87	32.122835	-103.567655
10,775.0	49.75	179.62	10,710.9	119.2	-295.8	409,246.85	778,374.99	32.122783	-103.567655
10,800.0	52.75	179.62	10,726.5	99.8	-295.7	409,227.36	778,375.12	32.122730	-103.567655
10,825.0	55.75	179.62	10,741.2	79.5	-295.5	409,207.07	778,375.26	32.122674	-103.567655
10,850.0	58.75	179.62	10,754.7	58.4	-295.4	409,186.05	778,375.40	32.122616	-103.567655
10,875.0	61.75	179.62	10,767.1	36.7	-295.3	409,164.35	778,375.54	32.122557	-103.567655
10,900.0	64.75	179.62	10,778.3	14.4	-295.1	409,142.02	778,375.69	32.122495	-103.567655
10,925.0	67.75	179.62	10,788.4	-8.5	-295.0	409,119.15	778,375.84	32.122432	-103.567655
10,950.0	70.75	179.62	10,797.3	-31.8	-294.8	409,095.77	778,376.00	32.122368	-103.567655
10,975.0	73.75	179.62	10,804.9	-55.6	-294.6	409,071.96	778,376.16	32.122303	-103.567655
11,000.0	76.75	179.62	10,811.2	-79.8	-294.5	409,047.79	778,376.32	32.122236	-103.567655
11,025.0	79.75	179.62	10,816.3	-104.3	-294.3	409,023.32	778,376.48	32.122169	-103.567655
11,050.0	82.75	179.62	10,820.1	-129.0	-294.2	408,998.61	778,376.64	32.122101	-103.567655
11,075.0	85.75	179.62	10,822.7	-153.9	-294.0	408,973.74	778,376.81	32.122033	-103.567655
11,100.0	88.75	179.62	10,823.9	-178.8	-293.8	408,948.78	778,376.98	32.121964	-103.567655
11,110.4	90.00	179.62	10,824.0	-189.3	-293.8	408,938.34	778,377.05	32.121935	-103.567655
EOB @ 90° Inc / 179.62° Azm / 10824' TVD									
11,200.0	90.00	179.62	10,824.0	-278.8	-293.2	408,848.78	778,377.64	32.121689	-103.567656
11,300.0	90.00	179.62	10,824.0	-378.8	-292.5	408,748.78	778,378.31	32.121414	-103.567656
11,400.0	90.00	179.62	10,824.0	-478.8	-291.8	408,648.78	778,378.98	32.121139	-103.567656
11,500.0	90.00	179.62	10,824.0	-578.8	-291.2	408,548.78	778,379.64	32.120865	-103.567656
11,600.0	90.00	179.62	10,824.0	-678.8	-290.5	408,448.79	778,380.31	32.120590	-103.567656
11,700.0	90.00	179.62	10,824.0	-778.8	-289.8	408,348.79	778,380.98	32.120315	-103.567656
11,800.0	90.00	179.62	10,824.0	-878.8	-289.2	408,248.79	778,381.64	32.120040	-103.567656
11,900.0	90.00	179.62	10,824.0	-978.8	-288.5	408,148.79	778,382.31	32.119765	-103.567656
12,000.0	90.00	179.62	10,824.0	-1,078.8	-287.8	408,048.80	778,382.98	32.119490	-103.567657
12,100.0	90.00	179.62	10,824.0	-1,178.8	-287.2	407,948.80	778,383.64	32.119215	-103.567657
12,200.0	90.00	179.62	10,824.0	-1,278.8	-286.5	407,848.80	778,384.31	32.118940	-103.567657
12,300.0	90.00	179.62	10,824.0	-1,378.8	-285.8	407,748.80	778,384.98	32.118666	-103.567657
12,400.0	90.00	179.62	10,824.0	-1,478.8	-285.2	407,648.80	778,385.64	32.118391	-103.567657
12,500.0	90.00	179.62	10,824.0	-1,578.8	-284.5	407,548.81	778,386.31	32.118116	-103.567657
12,600.0	90.00	179.62	10,824.0	-1,678.8	-283.8	407,448.81	778,386.98	32.117841	-103.567657
12,700.0	90.00	179.62	10,824.0	-1,778.8	-283.2	407,348.81	778,387.64	32.117566	-103.567658
12,800.0	90.00	179.62	10,824.0	-1,878.8	-282.5	407,248.81	778,388.31	32.117291	-103.567658
12,900.0	90.00	179.62	10,824.0	-1,978.8	-281.8	407,148.82	778,388.98	32.117016	-103.567658
13,000.0	90.00	179.62	10,824.0	-2,078.8	-281.2	407,048.82	778,389.64	32.116741	-103.567658
13,100.0	90.00	179.62	10,824.0	-2,178.8	-280.5	406,948.82	778,390.31	32.116467	-103.567658
13,200.0	90.00	179.62	10,824.0	-2,278.8	-279.8	406,848.82	778,390.97	32.116192	-103.567658
13,300.0	90.00	179.62	10,824.0	-2,378.8	-279.2	406,748.82	778,391.64	32.115917	-103.567658
13,400.0	90.00	179.62	10,824.0	-2,478.8	-278.5	406,648.83	778,392.31	32.115642	-103.567659
13,500.0	90.00	179.62	10,824.0	-2,578.8	-277.8	406,548.83	778,392.97	32.115367	-103.567659
13,600.0	90.00	179.62	10,824.0	-2,678.8	-277.2	406,448.83	778,393.64	32.115092	-103.567659
13,700.0	90.00	179.62	10,824.0	-2,778.8	-276.5	406,348.83	778,394.31	32.114817	-103.567659
13,800.0	90.00	179.62	10,824.0	-2,878.8	-275.8	406,248.84	778,394.97	32.114542	-103.567659
13,900.0	90.00	179.62	10,824.0	-2,978.8	-275.2	406,148.84	778,395.64	32.114268	-103.567659
14,000.0	90.00	179.62	10,824.0	-3,078.8	-274.5	406,048.84	778,396.31	32.113993	-103.567659
14,100.0	90.00	179.62	10,824.0	-3,178.8	-273.8	405,948.84	778,396.97	32.113718	-103.567660
14,200.0	90.00	179.62	10,824.0	-3,278.8	-273.2	405,848.84	778,397.64	32.113443	-103.567660
14,300.0	90.00	179.62	10,824.0	-3,378.8	-272.5	405,748.85	778,398.31	32.113168	-103.567660



QES
Survey Report - Geographic



Company:	BTA Oil Producers, LLC	Local Co-ordinate Reference:	Well Rojo 7811 22 Fed #73H
Project:	Lea County, NM (NAD 83)	TVD Reference:	WELL @ 3394.0usft (Patterson)
Site:	Sec 22, T25-S, R33-E	MD Reference:	WELL @ 3394.0usft (Patterson)
Well:	Rojo 7811 22 Fed #73H	North Reference:	Grid
Wellbore:	Wellbore #1	Survey Calculation Method:	Minimum Curvature
Design:	Design #1	Database:	EDM 5000.1 Single User Db

Planned Survey										
Measured Depth (usft)	Inclination (°)	Azimuth (°)	Vertical Depth (usft)	+N/-S (usft)	+E/-W (usft)	Map Northing (usft)	Map Easting (usft)	Latitude	Longitude	
14,400.0	90.00	179.62	10,824.0	-3,478.7	-271.8	405,648.85	778,398.97	32.112893	-103.567660	
14,500.0	90.00	179.62	10,824.0	-3,578.7	-271.2	405,548.85	778,399.64	32.112618	-103.567660	
14,600.0	90.00	179.62	10,824.0	-3,678.7	-270.5	405,448.85	778,400.31	32.112343	-103.567660	
14,700.0	90.00	179.62	10,824.0	-3,778.7	-269.8	405,348.86	778,400.97	32.112069	-103.567660	
14,800.0	90.00	179.62	10,824.0	-3,878.7	-269.2	405,248.86	778,401.64	32.111794	-103.567661	
14,900.0	90.00	179.62	10,824.0	-3,978.7	-268.5	405,148.86	778,402.31	32.111519	-103.567661	
15,000.0	90.00	179.62	10,824.0	-4,078.7	-267.8	405,048.86	778,402.97	32.111244	-103.567661	
15,100.0	90.00	179.62	10,824.0	-4,178.7	-267.2	404,948.86	778,403.64	32.110969	-103.567661	
15,200.0	90.00	179.62	10,824.0	-4,278.7	-266.5	404,848.87	778,404.31	32.110694	-103.567661	
15,300.0	90.00	179.62	10,824.0	-4,378.7	-265.8	404,748.87	778,404.97	32.110419	-103.567661	
15,400.0	90.00	179.62	10,824.0	-4,478.7	-265.2	404,648.87	778,405.64	32.110144	-103.567661	
15,500.0	90.00	179.62	10,824.0	-4,578.7	-264.5	404,548.87	778,406.31	32.109869	-103.567662	
15,600.0	90.00	179.62	10,824.0	-4,678.7	-263.8	404,448.88	778,406.97	32.109595	-103.567662	
15,700.0	90.00	179.62	10,824.0	-4,778.7	-263.2	404,348.88	778,407.64	32.109320	-103.567662	
15,800.0	90.00	179.62	10,824.0	-4,878.7	-262.5	404,248.88	778,408.31	32.109045	-103.567662	
15,843.8	90.00	179.62	10,824.0	-4,922.5	-262.2	404,205.10	778,408.60	32.108925	-103.567662	
TD @ 15844' MD / 10824' TVD										

Design Targets										
Target Name	Dip Angle (°)	Dip Dir. (°)	TVD (usft)	+N/-S (usft)	+E/-W (usft)	Northing (usft)	Easting (usft)	Latitude	Longitude	
VP Rojo 73H - hit/miss target - Shape - Point	0.00	0.00	7,564.0	288.2	-296.9	409,415.79	778,373.86	32.123248	-103.567655	
PBHL Rojo 7811 22 Fed - plan hits target center - Rectangle (sides W60.0 H0.0 D5,210.0)	90.00	179.62	10,824.0	-4,922.5	-262.2	404,205.10	778,408.60	32.108925	-103.567662	

Plan Annotations					
Measured Depth (usft)	Vertical Depth (usft)	Local Coordinates		Comment	
		+N/-S (usft)	+E/-W (usft)		
1300	1300	0	0	Build 2°/100'	
1495	1495	5	-5	EOB @ 3.9° Inc / 314.14° Azm	
7383	7369	284	-292	Drop 2°/100'	
7578	7564	288	-297	EOD @ Vert	
10,360	10,346	288	-297	Build 12°/100'	
11,110	10,824	-189	-294	EOB @ 90° Inc / 179.62° Azm / 10824' TVD	
15,844	10,824	-4923	-262	TD @ 15844' MD / 10824' TVD	

District I
1625 N. French Dr., Hobbs, NM 88240
District II
811 S. First St., Artesia, NM 88210
District III
1000 Rio Brazos Road, Aztec, NM 87410
District IV
1220 S. St. Francis Dr., Santa Fe, NM 87505

State of New Mexico
Energy, Minerals and Natural Resources Department
Oil Conservation Division
1220 South St. Francis Dr.
Santa Fe, NM 87505

Submit Original
to Appropriate
District Office

GAS CAPTURE PLAN

Date: 10/13/2020

Original Operator & OGRID No.: 260297
 Amended - Reason for Amendment: _____

This Gas Capture Plan outlines actions to be taken by the Operator to reduce well/production facility flaring/venting for new completion (new drill, recomplete to new zone, re-frac) activity.

Note: Form C-129 must be submitted and approved prior to exceeding 60 days allowed by Rule (Subsection A of 19.15.18.12 NMAC).

Well(s)/Production Facility – Name of facility

The well(s) that will be located at the production facility are shown in the table below.

Well Name	API	Well Location (ULSTR)	Footages	Expected MCF/D	Flared or Vented	Comments
ROJO 7811 22		SEC 22 ; 25S ; 33E	310 FNL 645 FWL	2000	Flared	Battery Connected
FEDERAL 73H						To ETP System

Gathering System and Pipeline Notification

Well(s) will be connected to a production facility after flowback operations are complete, if gas transporter system is in place. The gas produced from production facility is dedicated to Gas Transporter and will be connected to Gas Transporter low/high pressure gathering system located in LEA County, New Mexico. It will require 0 ' of pipeline to (ETP) connect the facility to low/high pressure gathering system. Operator provides (periodically) to Gas Transporter a drilling, completion and estimated first production date for wells that are scheduled to be drilled in the foreseeable future. In addition, Operator and Gas Transporter have periodic conference calls to discuss changes to drilling and completion schedules. Gas from these wells will be processed at Gas Transporter Processing Plant located in Sec.____, Twn.____, Rng.____, _____ County, New Mexico. The actual flow of the gas will be based on compression operating parameters and gathering system pressures.

Flowback Strategy

After the fracture treatment/completion operations, well(s) will be produced to temporary production tanks and gas will be flared or vented. During flowback, the fluids and sand content will be monitored. When the produced fluids contain minimal sand, the wells will be turned to production facilities. Gas sales should start as soon as the wells start flowing through the production facilities, unless there are operational issues on Gas Transporter system at that time. Based on current information, it is Operator's belief the system can take this gas upon completion of the well(s).

Safety requirements during cleanout operations from the use of underbalanced air cleanout systems may necessitate that sand and non-pipeline quality gas be vented and/or flared rather than sold on a temporary basis.

Alternatives to Reduce Flaring

Below are alternatives considered from a conceptual standpoint to reduce the amount of gas flared.

- Power Generation – On lease
 - Only a portion of gas is consumed operating the generator, remainder of gas will be flared
- Compressed Natural Gas – On lease
 - Gas flared would be minimal, but might be uneconomical to operate when gas volume declines
- NGL Removal – On lease
 - Plants are expensive, residue gas is still flared, and uneconomical to operate when gas volume declines

BOP Break Testing Request

BTA requests permission to allow BOP Break Testing under the following conditions:

- After a full BOP test is conducted on the first well on the pad.
- When skidding to drill a hole section that does not penetrate into the Wolfcamp.
- Full BOP test will be required prior to drilling any production hole.



Multi-Bowl System 13-3/8" X 9-5/8" X 5-1/2"

Tubing Head-TCM-PP

13-5/8" M X 7-1/16" M
w/(2) 1-13/16" M Gate Valves

7-1/16" M

Casing Spool- MBS

13-5/8"-5M X 13-5/8"- M
w/(2) 1-13/16" M SSO

13-5/8"- M

7" Dbl P Seal

13-5/8" X 7" C-22
Casing Hanger

Casing Head- MBS

13-5/8"-5M X 13-3/8" SOW
w/36" Base Plate

13-5/8"-5M

13-5/8" X 9-5/8" MBS
Packoff Assembly

13-5/8" X 9-5/8" Mandrel
Casing Hanger

13-3/8" SOW

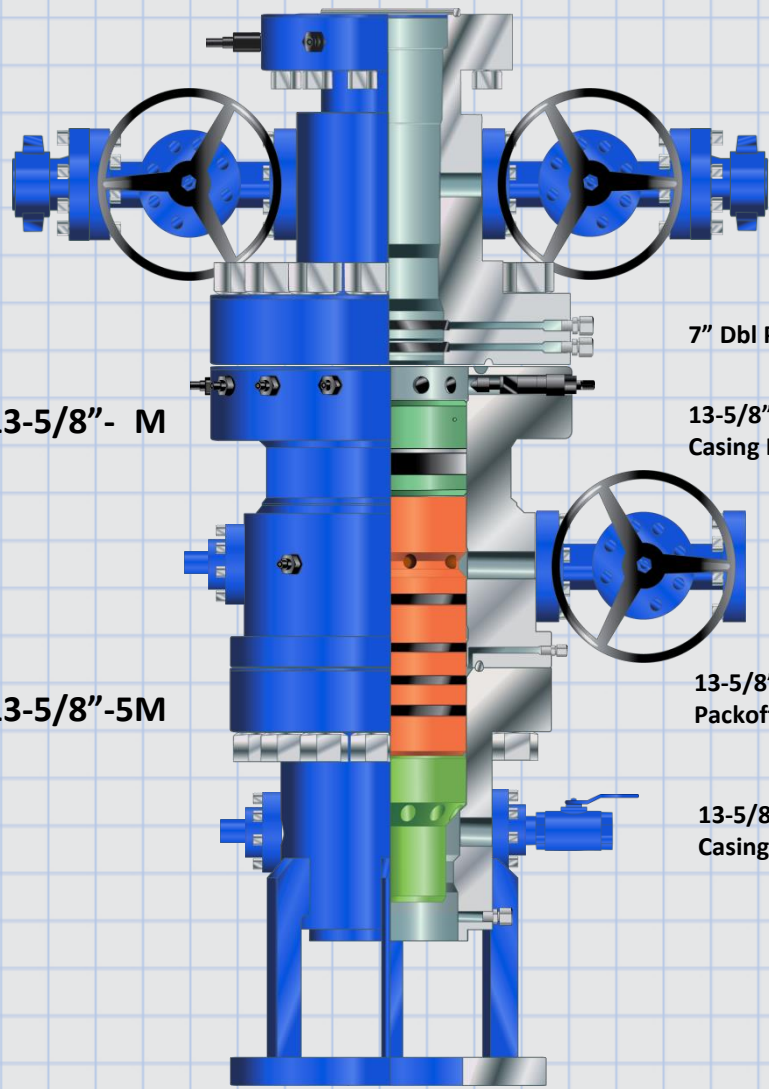

SYENERGY

WELLHEAD & FRAC



U.S. Department of the Interior
BUREAU OF LAND MANAGEMENT

SUPO Data Report

07/20/2021

APD ID: 10400066613

Submission Date: 12/16/2020

Highlighted data reflects the most recent changes

Operator Name: BTA OIL PRODUCERS LLC

Well Name: ROJO 7811 22 FEDERAL

Well Number: 73H

[Show Final Text](#)

Well Type: OIL WELL

Well Work Type: Drill

Section 1 - Existing Roads

Will existing roads be used? YES

Existing Road Map:

20110323_Rojo_7811_22_Fed_73H_Topographical___Access_Rd_20201211091655.pdf

Existing Road Purpose: ACCESS

Row(s) Exist? NO

ROW ID(s)

ID:

Do the existing roads need to be improved? NO

Existing Road Improvement Description:

Existing Road Improvement Attachment:

Section 2 - New or Reconstructed Access Roads

Will new roads be needed? YES

New Road Map:

20110323_Rojo_7811_22_Fed_73H_Topographical___Access_Rd_20201211091705.pdf

New road type: RESOURCE

Length: 253.6 Feet

Width (ft.): 30

Max slope (%): 2

Max grade (%): 2

Army Corp of Engineers (ACOE) permit required? N

ACOE Permit Number(s):

New road travel width: 30

New road access erosion control: Road construction requirements and regular maintenance would alleviate potential impacts to the access road from water erosion damage.

New road access plan or profile prepared? N

New road access plan attachment:

Access road engineering design? N

Access road engineering design attachment:

Operator Name: BTA OIL PRODUCERS LLC

Well Name: ROJO 7811 22 FEDERAL

Well Number: 73H

Turnout? N

Access surfacing type: OTHER

Access topsoil source: BOTH

Access surfacing type description: Native Caliche

Access onsite topsoil source depth: 6

Offsite topsoil source description: Material will be obtained from the closest existing caliche pit as designated by the BLM.

Onsite topsoil removal process: The top 6 inches of topsoil is pushed off and stockpiled along the side of the location. An approximate 160 X 160 area is used within the proposed well site to remove caliche. Subsoil is removed and stockpiled within the pad site to build the location and road. Then subsoil is pushed back in the hole and caliche is spread accordingly across proposed access road

Access other construction information:

Access miscellaneous information:

Number of access turnouts:

Access turnout map:

Drainage Control

New road drainage crossing: OTHER

Drainage Control comments: Proposed access road will be crowned and ditched and constructed of 6 inch rolled and compacted caliche. Water will be diverted where necessary to avoid ponding, maintain good drainage, and to be consistent with local drainage patterns.

Road Drainage Control Structures (DCS) description: Any ditches will be at 3:1 slope and 3 feet wide.

Road Drainage Control Structures (DCS) attachment:

Access Additional Attachments

Section 3 - Location of Existing Wells

Existing Wells Map? YES

Attach Well map:

20110323_Rojo_7811_22_Fed_73H__1_Mile_Radius_Plat_20201211091725.pdf

Section 4 - Location of Existing and/or Proposed Production Facilities

Submit or defer a Proposed Production Facilities plan? DEFER

Estimated Production Facilities description: Defer, CTB will be sundried at a later date.

Section 5 - Location and Types of Water Supply

Water Source Table

Operator Name: BTA OIL PRODUCERS LLC

Well Name: ROJO 7811 22 FEDERAL

Well Number: 73H

Water source type: OTHER

Describe type: PIT

Water source use type: SURFACE CASING
STIMULATION
DUST CONTROL
INTERMEDIATE/PRODUCTION CASING

Source latitude:

Source longitude:

Source datum:

Water source permit type: PRIVATE CONTRACT

Water source transport method: TRUCKING

Source land ownership: FEDERAL

Source transportation land ownership: PRIVATE

Water source volume (barrels): 100000

Source volume (acre-feet): 12.88930963

Source volume (gal): 4200000

Water source and transportation map:

Rojo_7811_Water_Transportation_Map__SESE_Quarter_Quarter_of_Section_S22_T25S_R33E__20201103153339.pdf

Water source comments: Water Pit is in SESE Quarter Quarter of Section 22 ; T25S ; R33E

New water well? N

New Water Well Info

Well latitude:

Well Longitude:

Well datum:

Well target aquifer:

Est. depth to top of aquifer(ft):

Est thickness of aquifer:

Aquifer comments:

Aquifer documentation:

Well depth (ft):

Well casing type:

Well casing outside diameter (in.):

Well casing inside diameter (in.):

New water well casing?

Used casing source:

Drilling method:

Drill material:

Grout material:

Grout depth:

Operator Name: BTA OIL PRODUCERS LLC

Well Name: ROJO 7811 22 FEDERAL

Well Number: 73H

Casing length (ft.):

Casing top depth (ft.):

Well Production type:

Completion Method:

Water well additional information:

State appropriation permit:

Additional information attachment:

Section 6 - Construction Materials

Using any construction materials: YES

Construction Materials description: Caliche used for construction of the drilling pad and access road will be obtained from the closest existing caliche pit as approved by the BLM or from prevailing deposits found under the location. If there is not sufficient material available, caliche will be purchased from the nearest caliche pit located in the SWNW Quarter Quarter of Section 23 ; T25S ; R33E Lea County, NM.

Construction Materials source location attachment:

Section 7 - Methods for Handling Waste

Waste type: GARBAGE

Waste content description: Trash

Amount of waste: 500 pounds

Waste disposal frequency : One Time Only

Safe containment description: Trash produced during drilling and completion operations will be collected in a trash container and disposed of properly.

Safe containmant attachment:

Waste disposal type: HAUL TO COMMERCIAL FACILITY **Disposal location ownership:** COMMERCIAL

Disposal type description:

Disposal location description: Trucked to a state approved disposal facility.

Waste type: SEWAGE

Waste content description: Human waste and grey water.

Amount of waste: 1000 gallons

Waste disposal frequency : One Time Only

Safe containment description: Waste material will be stored safely and disposed of properly.

Safe containmant attachment:

Waste disposal type: HAUL TO COMMERCIAL FACILITY **Disposal location ownership:** COMMERCIAL

Disposal type description:

Disposal location description: Trucked to a state approved disposal facility.

Operator Name: BTA OIL PRODUCERS LLC

Well Name: ROJO 7811 22 FEDERAL

Well Number: 73H

Waste type: DRILLING

Waste content description: Drilling fluids and cuttings.

Amount of waste: 4164 barrels

Waste disposal frequency : One Time Only

Safe containment description: All drilling fluids will be stored safely and disposed of properly.

Safe containmant attachment:

Waste disposal type: HAUL TO COMMERCIAL FACILITY **Disposal location ownership:** COMMERCIAL FACILITY

Disposal type description:

Disposal location description: Trucked to a state approved disposal facility.

Reserve Pit

Reserve Pit being used? NO

Temporary disposal of produced water into reserve pit? NO

Reserve pit length (ft.) **Reserve pit width (ft.)**

Reserve pit depth (ft.) **Reserve pit volume (cu. yd.)**

Is at least 50% of the reserve pit in cut?

Reserve pit liner

Reserve pit liner specifications and installation description

Cuttings Area

Cuttings Area being used? NO

Are you storing cuttings on location? N

Description of cuttings location

Cuttings area length (ft.) **Cuttings area width (ft.)**

Cuttings area depth (ft.) **Cuttings area volume (cu. yd.)**

Is at least 50% of the cuttings area in cut?

WCuttings area liner

Cuttings area liner specifications and installation description

Operator Name: BTA OIL PRODUCERS LLC

Well Name: ROJO 7811 22 FEDERAL

Well Number: 73H

Section 8 - Ancillary Facilities

Are you requesting any Ancillary Facilities?: N

Ancillary Facilities attachment:

Comments:

Section 9 - Well Site Layout

Well Site Layout Diagram:

Rig_Layout_20190930140859.pdf

20110323_Rojo_7811_22_Fed_73H__Well_Site_Plan_20201211091750.pdf

Rojo_71H_74H_Access_Road_Plat_20201216085020.pdf

Comments:

Section 10 - Plans for Surface Reclamation

Type of disturbance: New Surface Disturbance

Multiple Well Pad Name: ROJO 7811 22 FEDERAL

Multiple Well Pad Number: 71H, 72H, 73H and 74H

Recontouring attachment:

Drainage/Erosion control construction: During construction proper erosion control methods will be used to control erosion, runoff, and siltation of the surrounding area.

Drainage/Erosion control reclamation: Proper erosion control methods will be used on the area to control erosion, runoff, and siltation of the surrounding area.

Well pad proposed disturbance (acres): 4.95	Well pad interim reclamation (acres): 0.46	Well pad long term disturbance (acres): 4.49
Road proposed disturbance (acres): 0	Road interim reclamation (acres): 0	Road long term disturbance (acres): 0
Powerline proposed disturbance (acres): 0	Powerline interim reclamation (acres): 0	Powerline long term disturbance (acres): 0
Pipeline proposed disturbance (acres): 0	Pipeline interim reclamation (acres): 0	Pipeline long term disturbance (acres): 0
Other proposed disturbance (acres): 0	Other interim reclamation (acres): 0	Other long term disturbance (acres): 0
Total proposed disturbance: 4.95	Total interim reclamation: 0.46	Total long term disturbance: 4.49

Disturbance Comments:

Reconstruction method: The areas planned for interim reclamation will then be recontoured to the original contour if feasible, or if not feasible, to an interim contour that blends with the surrounding topography as much as possible. Where applicable, the fill material of the well pad will be backfilled into the cut to bring the area back to the original contour. The interim cut and fill slopes prior to re-seeding will not be steeper than a 3:1 ratio, unless the adjacent native topography is steeper. Note: Constructed slopes may be much steeper during drilling, but will be recontoured to the above ratios during interim reclamation.

Topsoil redistribution: Topsoil will be evenly respread and aggressively revegetated over the entire disturbed area not needed for all-weather operations.

Operator Name: BTA OIL PRODUCERS LLC

Well Name: ROJO 7811 22 FEDERAL

Well Number: 73H

Soil treatment: To seed the area, the proper BLM seed mixture, free of noxious weeds, will be used. Final seedbed preparation will consist of contour cultivating to a depth of 4 to 6 inches within 24 hours prior to seeding, dozer tracking, or other imprinting in order to break the soil crust and create seed germination micro-sites.

Existing Vegetation at the well pad: The historic climax plant community is a grassland dominated by black grama, dropseeds, and blue stems with sand sage and shinnery oak distributed evenly throughout. Current landscape displays mesquite, shinnery oak, yucca, desert sage, fourwing saltbush, snakeweed, and bunch grasses.

Existing Vegetation at the well pad attachment:

Existing Vegetation Community at the road: Refer to "Existing Vegetation at the well pad"

Existing Vegetation Community at the road attachment:

Existing Vegetation Community at the pipeline: Refer to "Existing Vegetation at the well pad"

Existing Vegetation Community at the pipeline attachment:

Existing Vegetation Community at other disturbances: Refer to "Existing Vegetation at the well pad"

Existing Vegetation Community at other disturbances attachment:

Non native seed used? N

Non native seed description:

Seedling transplant description:

Will seedlings be transplanted for this project? N

Seedling transplant description attachment:

Will seed be harvested for use in site reclamation?

Seed harvest description:

Seed harvest description attachment:

[Seed Management](#)

[Seed Table](#)

Seed Summary	
Seed Type	Pounds/Acre

Total pounds/Acre:

Seed reclamation attachment:

[Operator Contact/Responsible Official Contact Info](#)

Operator Name: BTA OIL PRODUCERS LLC

Well Name: ROJO 7811 22 FEDERAL

Well Number: 73H

First Name: Chad

Last Name: Smith

Phone: (432)682-3753

Email: CSMITH@btaoil.com

Seedbed prep:

Seed BMP:

Seed method:

Existing invasive species? N

Existing invasive species treatment description:

Existing invasive species treatment attachment:

Weed treatment plan description: No invasive species present. Standard regular maintenance to maintain a clear location and road.

Weed treatment plan attachment:

Monitoring plan description: Identify areas supporting weeds prior to construction; prevent the introduction and spread of weeds from construction equipment during construction; and contain weed seeds and propagules by preventing segregated topsoil from being spread to adjacent areas. No invasive species present. Standard regular maintenance to maintain a clear location and road.

Monitoring plan attachment:

Success standards: To maintain all disturbed areas as per Gold Book standards.

Pit closure description: N/A

Pit closure attachment:

Section 11 - Surface Ownership

Disturbance type: WELL PAD

Describe:

Surface Owner: BUREAU OF LAND MANAGEMENT

Other surface owner description:

BIA Local Office:

BOR Local Office:

COE Local Office:

DOD Local Office:

NPS Local Office:

State Local Office:

Military Local Office:

USFWS Local Office:

Other Local Office:

USFS Region:

Operator Name: BTA OIL PRODUCERS LLC

Well Name: ROJO 7811 22 FEDERAL

Well Number: 73H

USFS Forest/Grassland:

USFS Ranger District:

Disturbance type: NEW ACCESS ROAD

Describe:

Surface Owner: BUREAU OF LAND MANAGEMENT

Other surface owner description:

BIA Local Office:

BOR Local Office:

COE Local Office:

DOD Local Office:

NPS Local Office:

State Local Office:

Military Local Office:

USFWS Local Office:

Other Local Office:

USFS Region:

USFS Forest/Grassland:

USFS Ranger District:

Section 12 - Other Information

Right of Way needed? N

Use APD as ROW?

ROW Type(s):

ROW Applications

SUPO Additional Information:

Use a previously conducted onsite? Y

Operator Name: BTA OIL PRODUCERS LLC

Well Name: ROJO 7811 22 FEDERAL

Well Number: 73H

Previous Onsite information: Onsite conducted by McKenna Ryder BLM on 10/8/2020

[Other SUPO Attachment](#)

TOPOGRAPHIC AND ACCESS ROAD MAP

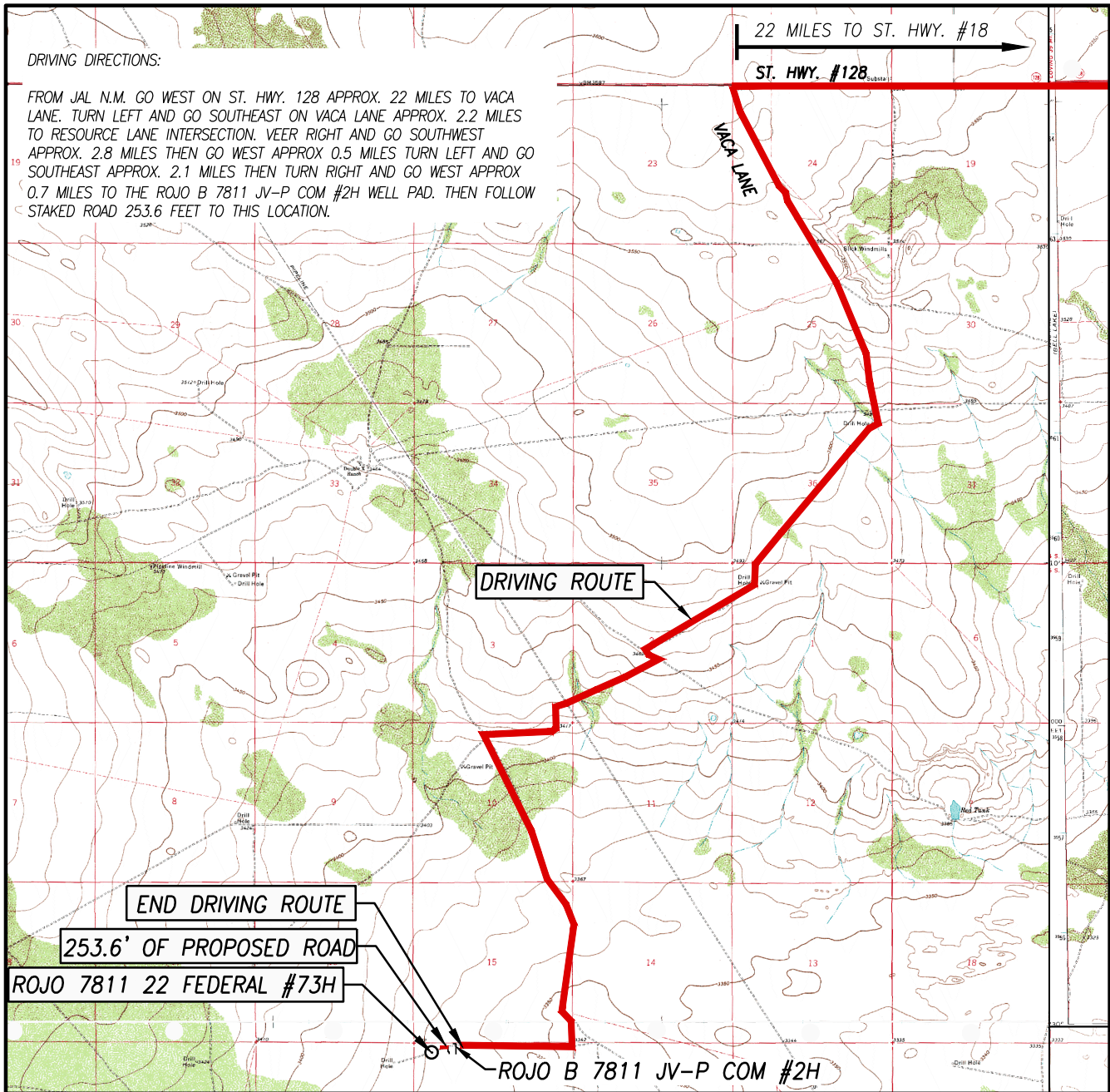

SCALE: 1" = 5280'

CONTOUR INTERVAL:

BELL LAKE, N.M. - 10'

SEC. 22 TWP. 25-S RGE. 33-E

SURVEY _____ N.M.P.M.

COUNTY LEA STATE NEW MEXICO

DESCRIPTION 310' FNL & 645' FWL

ELEVATION 3369'

OPERATOR BTA OIL PRODUCERS, LLC

LEASE ROJO 7811 22 FEDERAL

U.S.G.S. TOPOGRAPHIC MAP

BELL LAKE, N.M.

I, RONALD J. EIDSON, NEW MEXICO PROFESSIONAL SURVEYOR No. 3239, DO HEREBY CERTIFY THAT THIS SURVEY PLAN AND THE ACTUAL SURVEY ON THE GROUND UPON WHICH IT IS BASED WERE PERFORMED BY ME OR UNDER MY DIRECT SUPERVISION; THAT I AM RESPONSIBLE FOR THIS SURVEY; THAT THIS SURVEY MEETS THE MINIMUM STANDARDS FOR SURVEYING IN NEW MEXICO; AND THAT IT IS TRUE AND CORRECT TO THE BEST OF MY KNOWLEDGE AND BELIEF.

RONALD J. EIDSON: *Ronald J. Eidson*

DATE: 09/24/2020

PROVIDING SURVEYING SERVICES
 SINCE 1946
JOHN WEST SURVEYING COMPANY
 412 N. DAL PASO HOBBS, N.M. 88240
 (575) 393-3117 www.jwsc.biz
 TBPLS# 10021000

TOPOGRAPHIC AND ACCESS ROAD MAP

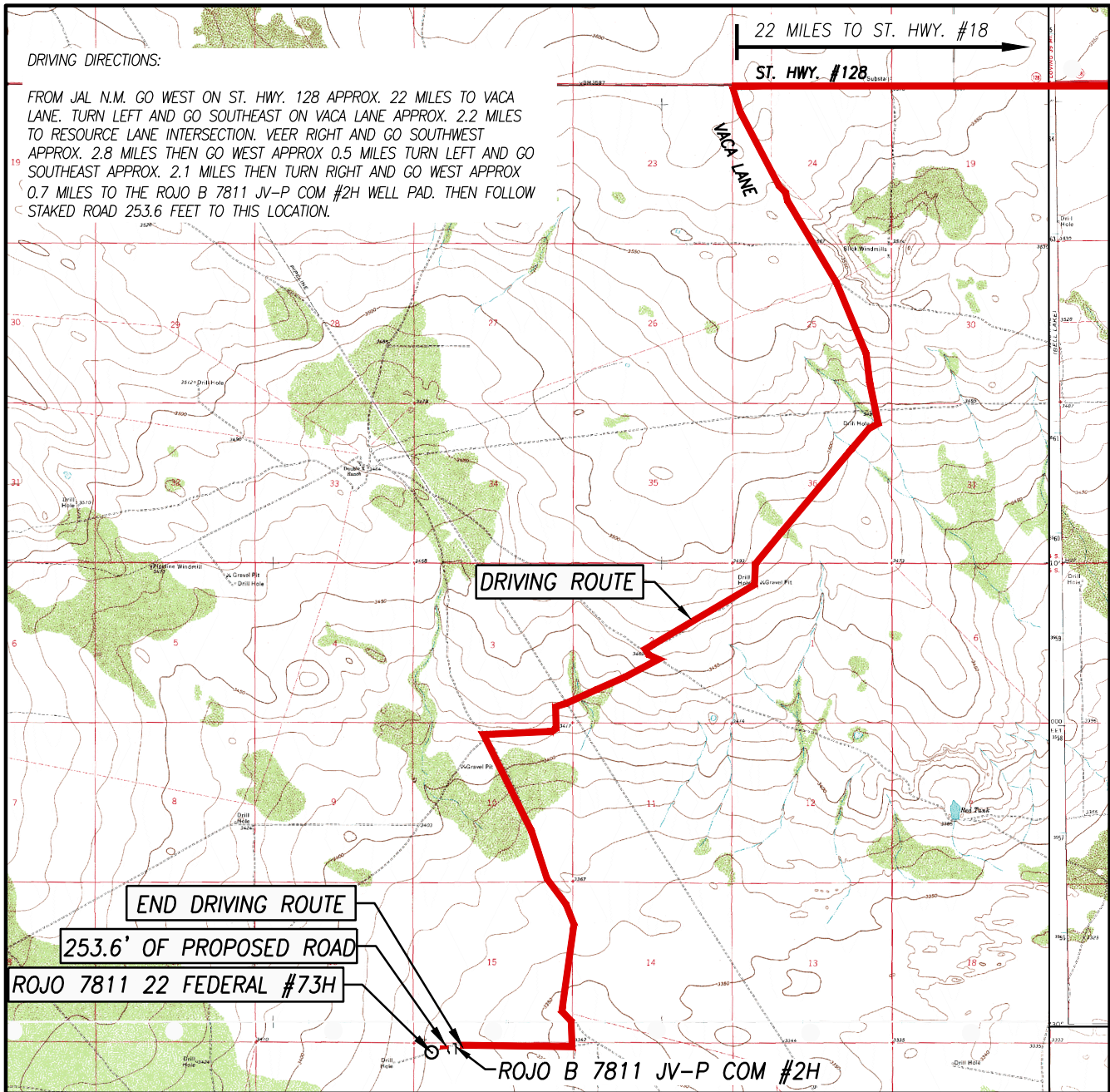

SCALE: 1" = 5280'

CONTOUR INTERVAL:

BELL LAKE, N.M. - 10'

SEC. 22 TWP. 25-S RGE. 33-E

SURVEY _____ N.M.P.M.

COUNTY LEA STATE NEW MEXICO

DESCRIPTION 310' FNL & 645' FWL

ELEVATION 3369'

OPERATOR BTA OIL PRODUCERS, LLC

LEASE ROJO 7811 22 FEDERAL

U.S.G.S. TOPOGRAPHIC MAP
BELL LAKE, N.M.

I, RONALD J. EIDSON, NEW MEXICO PROFESSIONAL SURVEYOR No. 3239, DO HEREBY CERTIFY THAT THIS SURVEY PLAN AND THE ACTUAL SURVEY ON THE GROUND UPON WHICH IT IS BASED WERE PERFORMED BY ME OR UNDER MY DIRECT SUPERVISION; THAT I AM RESPONSIBLE FOR THIS SURVEY; THAT THIS SURVEY MEETS THE MINIMUM STANDARDS FOR SURVEYING IN NEW MEXICO; AND THAT IT IS TRUE AND CORRECT TO THE BEST OF MY KNOWLEDGE AND BELIEF.

RONALD J. EIDSON: *Ronald J. Eidson*

DATE: 09/24/2020

PROVIDING SURVEYING SERVICES
SINCE 1946
JOHN WEST SURVEYING COMPANY
 412 N. DAL PASO HOBBS, N.M. 88240
 (575) 393-3117 www.jwsc.biz
 TBPLS# 10021000

DISTRICT I
1625 N. French Dr., Hobbs, NM 88240
Phone: (575) 393-6161 Fax: (575) 393-0720
DISTRICT II
811 S. First St., Artesia, NM 88210
Phone: (575) 748-1283 Fax: (575) 748-9720
DISTRICT III
1000 Rio Brazos Road, Aztec, NM 87410
Phone: (505) 334-6178 Fax: (505) 334-6170
DISTRICT IV
1220 S. St. Francis Dr., Santa Fe, NM 87505
Phone: (505) 476-3460 Fax: (505) 476-3462

State of New Mexico
Energy, Minerals & Natural Resources Department
OIL CONSERVATION DIVISION
1220 South St. Francis Dr.
Santa Fe, New Mexico 87505

Form C-102
Revised August 1, 2011
Submit one copy to appropriate
District Office

AMENDED REPORT

WELL LOCATION AND ACREAGE DEDICATION PLAT

API Number	Pool Code	Pool Name
		Red Hills ; 2nd Bone Spring
Property Code	Property Name	Well Number
	ROJO 7811 22 FEDERAL	73H
OGRID No.	Operator Name	Elevation
260297	BTA OIL PRODUCERS, LLC	3369'

Surface Location

UL or lot No.	Section	Township	Range	Lot Idn	Feet from the	North/South line	Feet from the	East/West line	County
D	22	25-S	33-E		310	NORTH	645	WEST	LEA

Bottom Hole Location If Different From Surface

UL or lot No.	Section	Township	Range	Lot Idn	Feet from the	North/South line	Feet from the	East/West line	County
M	22	25-S	33-E		50	SOUTH	350	WEST	LEA

Dedicated Acres	Joint or Infill	Consolidation Code	Order No.
160			

NO ALLOWABLE WILL BE ASSIGNED TO THIS COMPLETION UNTIL ALL INTERESTS HAVE BEEN CONSOLIDATED OR A NON-STANDARD UNIT HAS BEEN APPROVED BY THE DIVISION

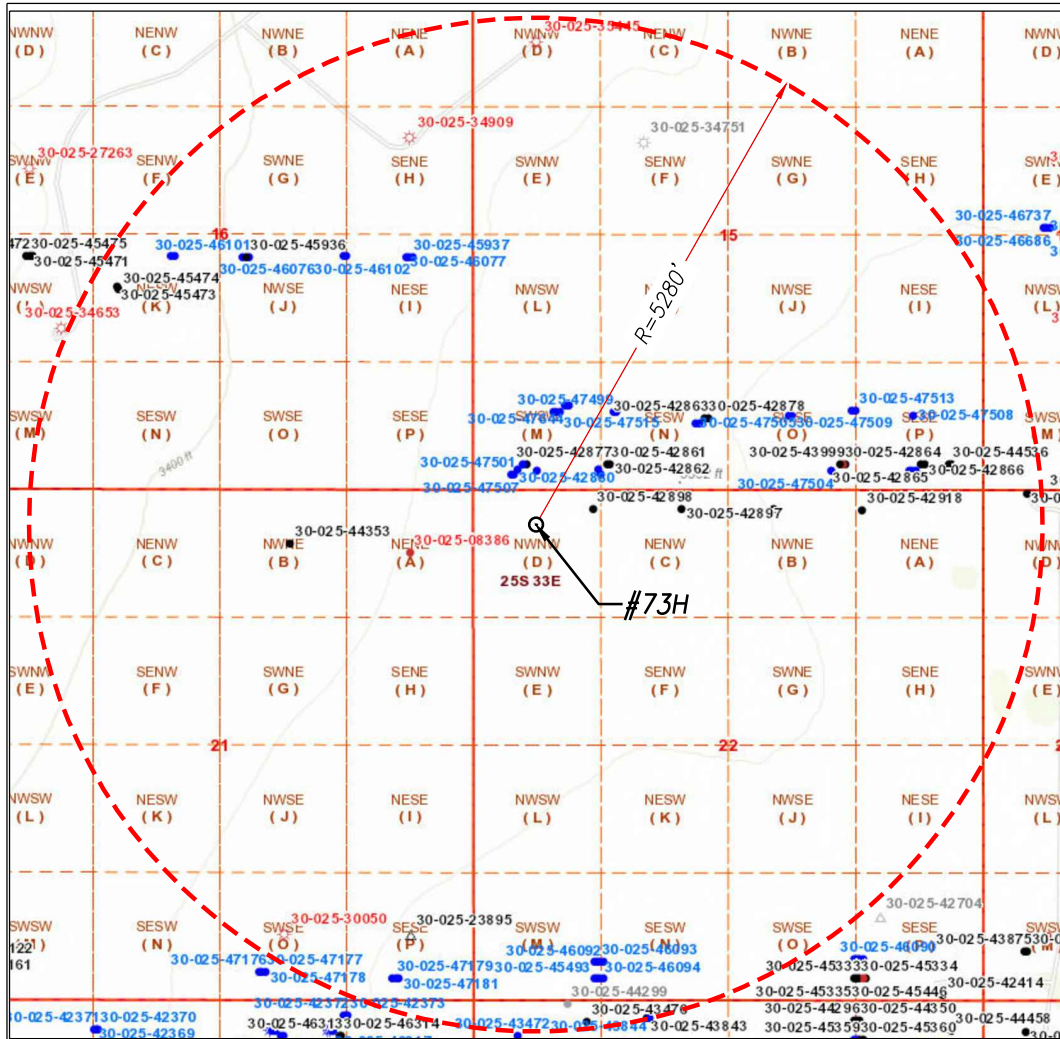

LEGEND
⊙ DENOTES PROPOSED WELL

10/13/2020

Sammy Hajar
SHAJAR@BTAOIL.COM

SURVEYOR CERTIFICATION

I hereby certify that the well location shown on this plat was plotted from field notes of actual surveys made by me or under my supervision and that the same is true and correct to the best of my belief.

Date of Survey: July 07, 2020
Signature & Seal of Professional Surveyor: 3239

Ronald J. Eidson
REGISTERED PROFESSIONAL SURVEYOR

Certificate Number: Gary G. Eidson 12641, Ronald J. Eidson 3239

LSL: JWSC W.O.: 20.11.0323

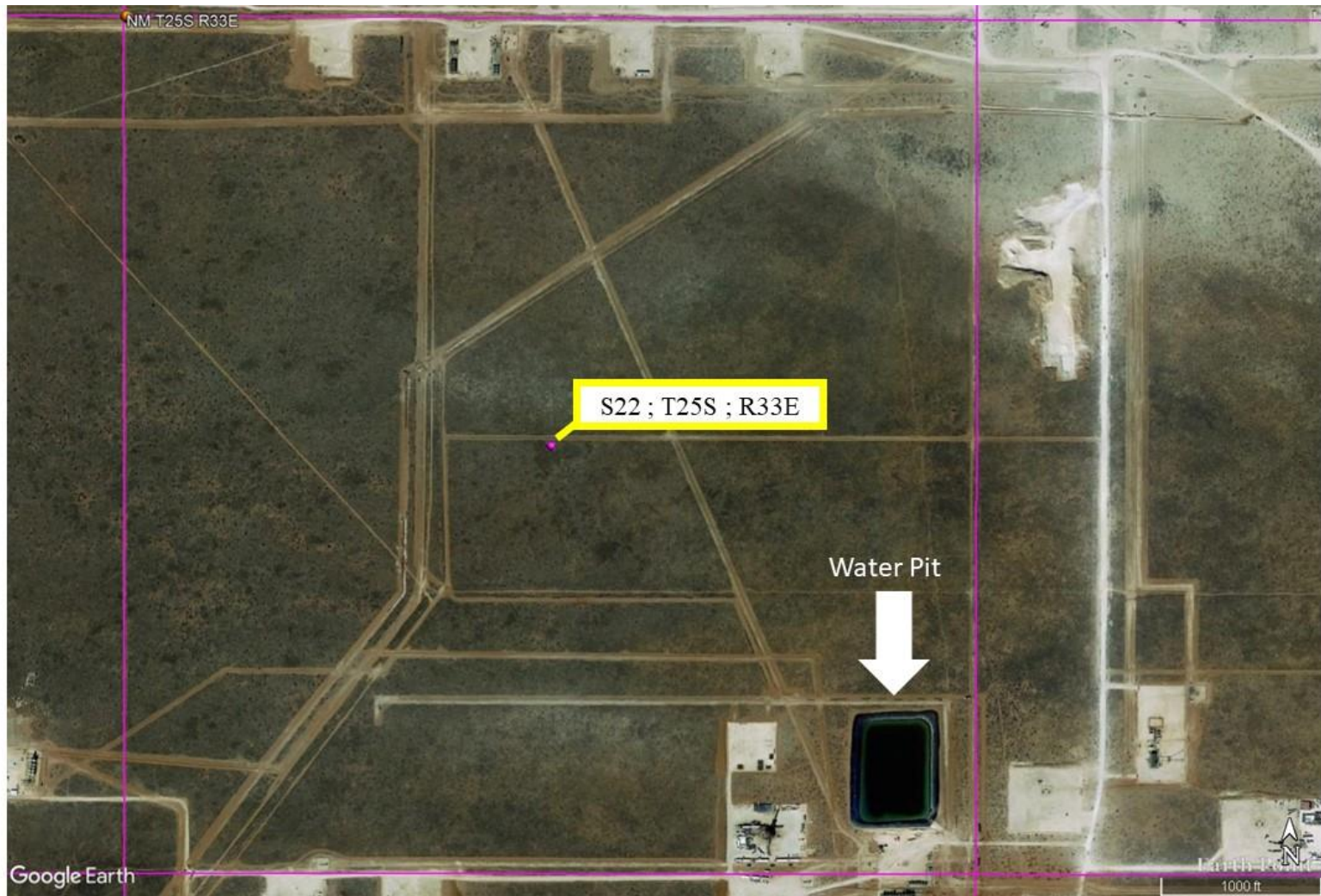

BTA OIL PRODUCERS, LLC
WATER TRANSPORTATION MAP
ROJO 7811 Federal WATER PIT
SEC 22 ; T25S ; R33E (Water Pit is in SESE QUARTER QUARTER)
LEA COUNTY, NM



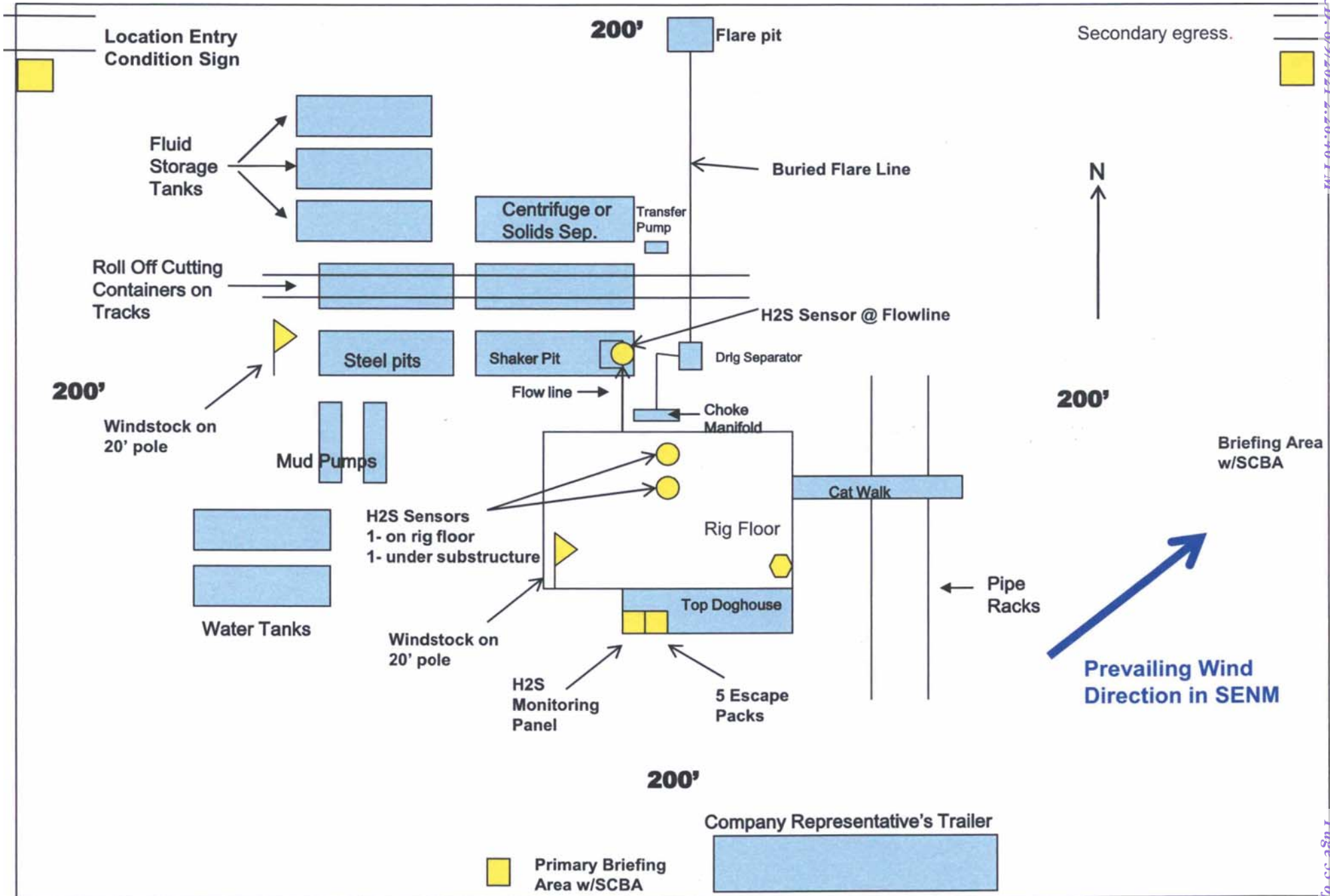

WELL SITE PLAN

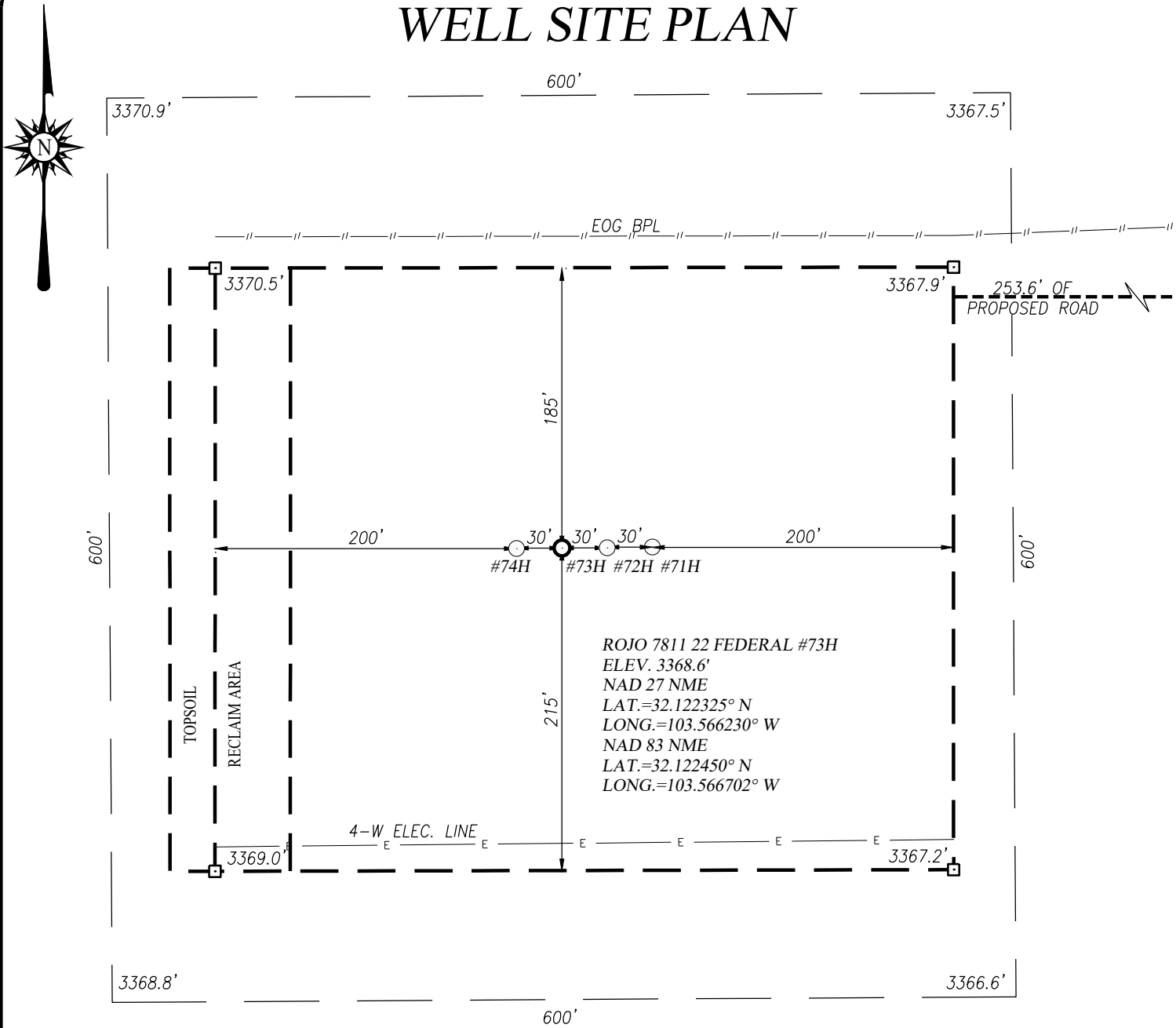

ROJO 7811 22 FEDERAL #73H
 ELEV. 3368.6'
 NAD 27 NME
 LAT.=32.122325° N
 LONG.=103.566230° W
 NAD 83 NME
 LAT.=32.122450° N
 LONG.=103.566702° W

NOTE:
 1) SEE "TOPOGRAPHICAL AND ACCESS ROAD MAP" FOR PROPOSED ROAD LOCATION.

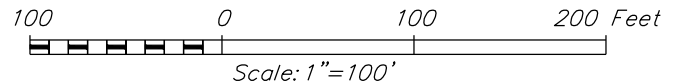

I, RONALD J. EIDSON, NEW MEXICO PROFESSIONAL SURVEYOR No. 3239, DO HEREBY CERTIFY THAT THIS SURVEY PLAT AND THE ACTUAL SURVEY ON THE GROUND UPON WHICH IT IS BASED WERE PERFORMED BY ME OR UNDER MY DIRECT SUPERVISION; THAT I AM RESPONSIBLE FOR THIS SURVEY; THAT THIS SURVEY MEETS THE MINIMUM STANDARDS FOR SURVEYING IN NEW MEXICO; AND THAT IT IS TRUE AND CORRECT TO THE BEST OF MY KNOWLEDGE AND BELIEF.

RONALD J. EIDSON
 DATE: 09/24/2020

BTA OIL PRODUCERS, LLC

ROJO 7811 22 FEDERAL #73H WELL LOCATED 310 FEET FROM THE NORTH LINE AND 645 FEET FROM THE WEST LINE OF SECTION 22, TOWNSHIP 25 SOUTH, RANGE 33 EAST, N.M.P.M., LEA COUNTY, NEW MEXICO

PROVIDING SURVEYING SERVICES SINCE 1946
JOHN WEST SURVEYING COMPANY
 412 N. DAL PASO HOBBS, N.M. 88240
 (575) 393-3117 www.jwsc.biz
 TBPLS# 10021000

Survey Date: 07/07/2020	CAD Date: 09/22/2020	Drawn By: LSL
W.O. No.: 20110323	Rev: .	Rel. W.O.: Sheet 1 of 1

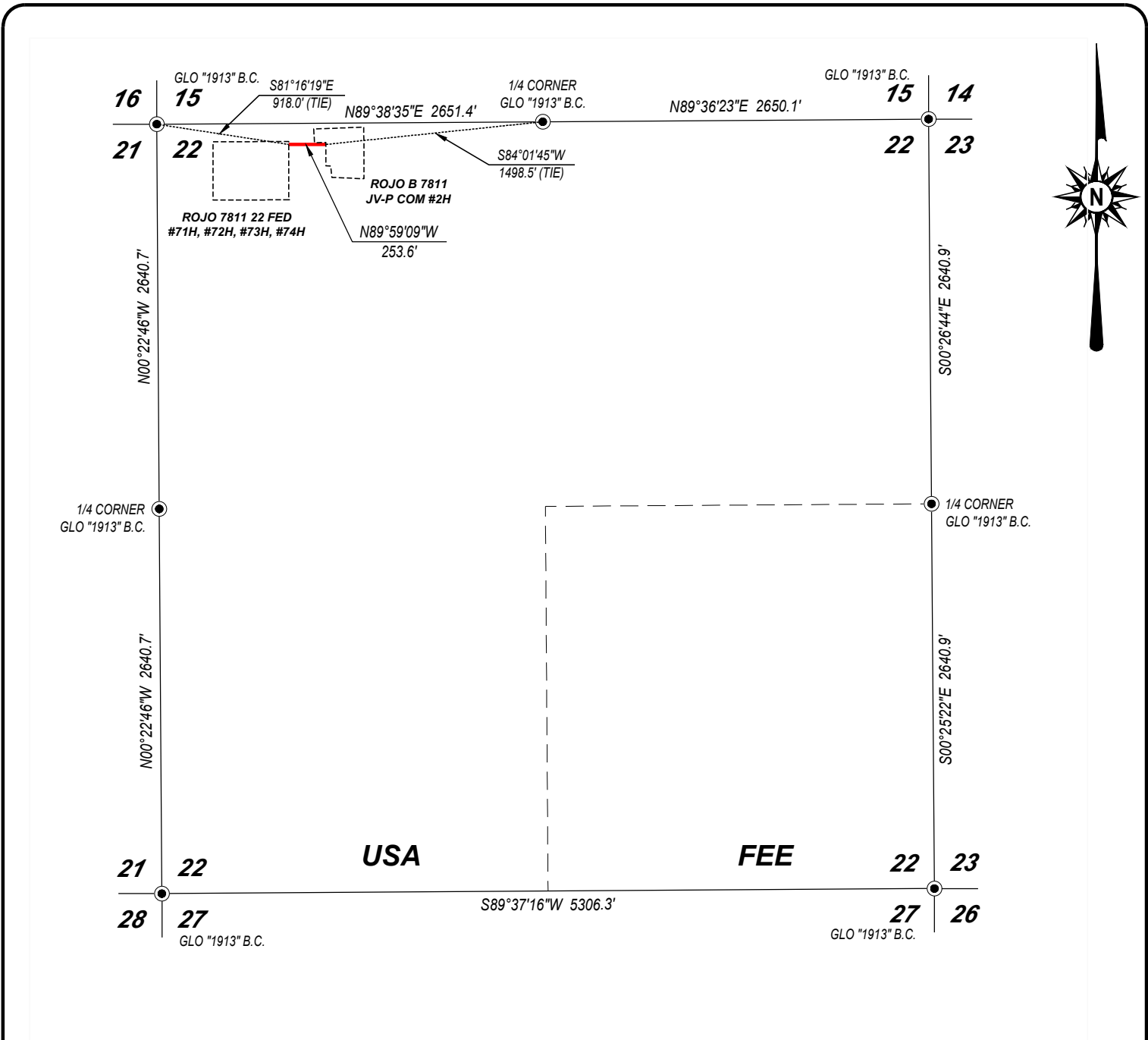

DESCRIPTION

SURVEY FOR A STRIP OF LAND 30.0 FEET WIDE AND 253.6 FEET OR 0.048 MILES IN LENGTH CROSSING USA LAND IN SECTION 22, TOWNSHIP 25 SOUTH, RANGE 33 EAST, N.M.P.M., LEA COUNTY, NEW MEXICO, AND BEING 15.0 FEET LEFT AND 15.0 FEET RIGHT OF THE ABOVE PLATTED CENTERLINE SURVEY.



NOTE

BEARINGS SHOWN HEREON ARE MERCATOR GRID AND CONFORM TO THE NEW MEXICO COORDINATE SYSTEM "NEW MEXICO EAST ZONE" NORTH AMERICAN DATUM 1983. DISTANCES ARE SURFACE VALUES.

I, RONALD J. EIDSON, NEW MEXICO PROFESSIONAL SURVEYOR No. 3239, DO HEREBY CERTIFY THAT THIS SURVEY PLAT AND THE ACTUAL SURVEY ON THE GROUND UPON WHICH IT IS BASED WERE PERFORMED BY ME OR UNDER MY DIRECT SUPERVISION; THAT I AM RESPONSIBLE FOR THIS SURVEY; THAT THIS SURVEY MEETS THE MINIMUM STANDARDS FOR SURVEYING IN NEW MEXICO; AND THAT IT IS TRUE AND CORRECT TO THE BEST OF MY KNOWLEDGE AND BELIEF.

RONALD J. EIDSON Ronald J. Eidson
 DATE: 12/14/2020

LEGEND

- DENOTES FOUND CORNER AS NOTED
- DENOTES CENTERLINE SURVEY

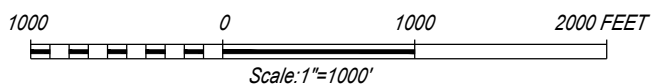

BTA OIL PRODUCERS, LLC

**SURVEY FOR ACCESS ROAD TO THE ROJO 7811
 22 FED #71H, #72H, #73H, #74H
 CROSSING SECTION 22,
 TOWNSHIP 25 SOUTH, RANGE 33 EAST, N.M.P.M.
 LEA COUNTY, NEW MEXICO**

Survey Date: 7/07/2020	CAD Date: 12/13/2020	Drawn By: LSL
W.O. No.: 20130578	Rev: .	Rel. W.O.: 20110321

PROVIDING SURVEYING SERVICES SINCE 1946
JOHN WEST SURVEYING COMPANY
 412 N. DAL PASO HOBBS, N.M. 88240
 (575) 393-3117 www.jwsc.biz
 TBPLS# 10021000



U.S. Department of the Interior
BUREAU OF LAND MANAGEMENT

PWD Data Report

07/20/2021

APD ID: 10400066613

Submission Date: 12/16/2020

Operator Name: BTA OIL PRODUCERS LLC

Well Name: ROJO 7811 22 FEDERAL

Well Number: 73H

Well Type: OIL WELL

Well Work Type: Drill

Section 1 - General

Would you like to address long-term produced water disposal? NO

Section 2 - Lined Pits

Would you like to utilize Lined Pit PWD options? N

Produced Water Disposal (PWD) Location:

PWD surface owner:

PWD disturbance (acres):

Lined pit PWD on or off channel:

Lined pit PWD discharge volume (bbl/day):

Lined pit specifications:

Pit liner description:

Pit liner manufacturers information:

Precipitated solids disposal:

Decribe precipitated solids disposal:

Precipitated solids disposal permit:

Lined pit precipitated solids disposal schedule:

Lined pit precipitated solids disposal schedule attachment:

Lined pit reclamation description:

Lined pit reclamation attachment:

Leak detection system description:

Leak detection system attachment:

Operator Name: BTA OIL PRODUCERS LLC

Well Name: ROJO 7811 22 FEDERAL

Well Number: 73H

Lined pit Monitor description:

Lined pit Monitor attachment:

Lined pit: do you have a reclamation bond for the pit?

Is the reclamation bond a rider under the BLM bond?

Lined pit bond number:

Lined pit bond amount:

Additional bond information attachment:

Section 3 - Unlined Pits

Would you like to utilize Unlined Pit PWD options? N

Produced Water Disposal (PWD) Location:

PWD disturbance (acres):

PWD surface owner:

Unlined pit PWD on or off channel:

Unlined pit PWD discharge volume (bbl/day):

Unlined pit specifications:

Precipitated solids disposal:

Describe precipitated solids disposal:

Precipitated solids disposal permit:

Unlined pit precipitated solids disposal schedule:

Unlined pit precipitated solids disposal schedule attachment:

Unlined pit reclamation description:

Unlined pit reclamation attachment:

Unlined pit Monitor description:

Unlined pit Monitor attachment:

Do you propose to put the produced water to beneficial use?

Beneficial use user confirmation:

Estimated depth of the shallowest aquifer (feet):

Does the produced water have an annual average Total Dissolved Solids (TDS) concentration equal to or less than that of the existing water to be protected?

TDS lab results:

Geologic and hydrologic evidence:

State authorization:

Unlined Produced Water Pit Estimated percolation:

Unlined pit: do you have a reclamation bond for the pit?

Operator Name: BTA OIL PRODUCERS LLC

Well Name: ROJO 7811 22 FEDERAL

Well Number: 73H

Is the reclamation bond a rider under the BLM bond?

Unlined pit bond number:

Unlined pit bond amount:

Additional bond information attachment:

Section 4 - Injection

Would you like to utilize Injection PWD options? N

Produced Water Disposal (PWD) Location:

PWD surface owner:

PWD disturbance (acres):

Injection PWD discharge volume (bbl/day):

Injection well mineral owner:

Injection well type:

Injection well number:

Injection well name:

Assigned injection well API number?

Injection well API number:

Injection well new surface disturbance (acres):

Minerals protection information:

Mineral protection attachment:

Underground Injection Control (UIC) Permit?

UIC Permit attachment:

Section 5 - Surface Discharge

Would you like to utilize Surface Discharge PWD options? N

Produced Water Disposal (PWD) Location:

PWD surface owner:

PWD disturbance (acres):

Surface discharge PWD discharge volume (bbl/day):

Surface Discharge NPDES Permit?

Surface Discharge NPDES Permit attachment:

Surface Discharge site facilities information:

Surface discharge site facilities map:

Section 6 - Other

Would you like to utilize Other PWD options? N

Produced Water Disposal (PWD) Location:

PWD surface owner:

PWD disturbance (acres):

Other PWD discharge volume (bbl/day):

Operator Name: BTA OIL PRODUCERS LLC

Well Name: ROJO 7811 22 FEDERAL

Well Number: 73H

Other PWD type description:

Other PWD type attachment:

Have other regulatory requirements been met?

Other regulatory requirements attachment:



U.S. Department of the Interior
BUREAU OF LAND MANAGEMENT

Bond Info Data Report

07/20/2021

APD ID: 10400066613

Submission Date: 12/16/2020

Highlighted data reflects the most recent changes

Operator Name: BTA OIL PRODUCERS LLC

Well Name: ROJO 7811 22 FEDERAL

Well Number: 73H

[Show Final Text](#)

Well Type: OIL WELL

Well Work Type: Drill

Bond Information

Federal/Indian APD: FED

BLM Bond number: NMB001711

BIA Bond number:

Do you have a reclamation bond? NO

Is the reclamation bond a rider under the BLM bond?

Is the reclamation bond BLM or Forest Service?

BLM reclamation bond number:

Forest Service reclamation bond number:

Forest Service reclamation bond attachment:

Reclamation bond number:

Reclamation bond amount:

Reclamation bond rider amount:

Additional reclamation bond information attachment:

State of New Mexico
Energy, Minerals and Natural Resources Department

Submit Electronically
Via E-permitting

Oil Conservation Division
1220 South St. Francis Dr.
Santa Fe, NM 87505

NATURAL GAS MANAGEMENT PLAN

This Natural Gas Management Plan must be submitted with each Application for Permit to Drill (APD) for a new or recompleted well.

Section 1 – Plan Description

Effective May 25, 2021

I. Operator: BTA Oil Producers, LLC **OGRID:** 260297 **Date:** 08 / 09 / 2021

II. Type: Original Amendment due to 19.15.27.9.D(6)(a) NMAC 19.15.27.9.D(6)(b) NMAC Other.

If Other, please describe: _____

III. Well(s): Provide the following information for each new or recompleted well or set of wells proposed to be drilled or proposed to be recompleted from a single well pad or connected to a central delivery point.

Well Name	API	ULSTR	Footages	Anticipated Oil BBL/D	Anticipated Gas MCF/D	Anticipated Produced Water BBL/D
ROJO 7811 22	30-025-49299	D ; SEC 22 ; 25S ; 33E	310 FNL,645 FWL	+/- 800	+/- 2000	+/- 1200
FEDERAL 73H						

IV. Central Delivery Point Name: Rojo 7811 CTB [See 19.15.27.9(D)(1) NMAC]

V. Anticipated Schedule: Provide the following information for each new or recompleted well or set of wells proposed to be drilled or proposed to be recompleted from a single well pad or connected to a central delivery point.

Well Name	API	Spud Date	TD Reached Date	Completion Commencement Date	Initial Flow Back Date	First Production Date
ROJO 7811 22	30-025-49299	8/9/2022	8/29/2022	9/12/2022	10/3/2022	11/2/2022
FEDERAL 73H						

VI. Separation Equipment: Attach a complete description of how Operator will size separation equipment to optimize gas capture.

VII. Operational Practices: Attach a complete description of the actions Operator will take to comply with the requirements of Subsection A through F of 19.15.27.8 NMAC.

VIII. Best Management Practices: Attach a complete description of Operator's best management practices to minimize venting during active and planned maintenance.

Section 2 – Enhanced Plan

EFFECTIVE APRIL 1, 2022

Beginning April 1, 2022, an operator that is not in compliance with its statewide natural gas capture requirement for the applicable reporting area must complete this section.

Operator certifies that it is not required to complete this section because Operator is in compliance with its statewide natural gas capture requirement for the applicable reporting area.

IX. Anticipated Natural Gas Production:

Well	API	Anticipated Average Natural Gas Rate MCF/D	Anticipated Volume of Natural Gas for the First Year MCF

X. Natural Gas Gathering System (NGGS):

Operator	System	ULSTR of Tie-in	Anticipated Gathering Start Date	Available Maximum Daily Capacity of System Segment Tie-in

XI. Map. Attach an accurate and legible map depicting the location of the well(s), the anticipated pipeline route(s) connecting the production operations to the existing or planned interconnect of the natural gas gathering system(s), and the maximum daily capacity of the segment or portion of the natural gas gathering system(s) to which the well(s) will be connected.

XII. Line Capacity. The natural gas gathering system will will not have capacity to gather 100% of the anticipated natural gas production volume from the well prior to the date of first production.

XIII. Line Pressure. Operator does does not anticipate that its existing well(s) connected to the same segment, or portion, of the natural gas gathering system(s) described above will continue to meet anticipated increases in line pressure caused by the new well(s).

Attach Operator’s plan to manage production in response to the increased line pressure.

XIV. Confidentiality: Operator asserts confidentiality pursuant to Section 71-2-8 NMSA 1978 for the information provided in Section 2 as provided in Paragraph (2) of Subsection D of 19.15.27.9 NMAC, and attaches a full description of the specific information for which confidentiality is asserted and the basis for such assertion.

Section 3 - Certifications

Effective May 25, 2021

Operator certifies that, after reasonable inquiry and based on the available information at the time of submittal:

Operator will be able to connect the well(s) to a natural gas gathering system in the general area with sufficient capacity to transport one hundred percent of the anticipated volume of natural gas produced from the well(s) commencing on the date of first production, taking into account the current and anticipated volumes of produced natural gas from other wells connected to the pipeline gathering system; or

Operator will not be able to connect to a natural gas gathering system in the general area with sufficient capacity to transport one hundred percent of the anticipated volume of natural gas produced from the well(s) commencing on the date of first production, taking into account the current and anticipated volumes of produced natural gas from other wells connected to the pipeline gathering system.

If Operator checks this box, Operator will select one of the following:

Well Shut-In. Operator will shut-in and not produce the well until it submits the certification required by Paragraph (4) of Subsection D of 19.15.27.9 NMAC; or

Venting and Flaring Plan. Operator has attached a venting and flaring plan that evaluates and selects one or more of the potential alternative beneficial uses for the natural gas until a natural gas gathering system is available, including:

- (a) power generation on lease;
- (b) power generation for grid;
- (c) compression on lease;
- (d) liquids removal on lease;
- (e) reinjection for underground storage;
- (f) reinjection for temporary storage;
- (g) reinjection for enhanced oil recovery;
- (h) fuel cell production; and
- (i) other alternative beneficial uses approved by the division.

Section 4 - Notices

1. If, at any time after Operator submits this Natural Gas Management Plan and before the well is spud:

(a) Operator becomes aware that the natural gas gathering system it planned to connect the well(s) to has become unavailable or will not have capacity to transport one hundred percent of the production from the well(s), no later than 20 days after becoming aware of such information, Operator shall submit for OCD's approval a new or revised venting and flaring plan containing the information specified in Paragraph (5) of Subsection D of 19.15.27.9 NMAC; or

(b) Operator becomes aware that it has, cumulatively for the year, become out of compliance with its baseline natural gas capture rate or natural gas capture requirement, no later than 20 days after becoming aware of such information, Operator shall submit for OCD's approval a new or revised Natural Gas Management Plan for each well it plans to spud during the next 90 days containing the information specified in Paragraph (2) of Subsection D of 19.15.27.9 NMAC, and shall file an update for each Natural Gas Management Plan until Operator is back in compliance with its baseline natural gas capture rate or natural gas capture requirement.

2. OCD may deny or conditionally approve an APD if Operator does not make a certification, fails to submit an adequate venting and flaring plan which includes alternative beneficial uses for the anticipated volume of natural gas produced, or if OCD determines that Operator will not have adequate natural gas takeaway capacity at the time a well will be spud.

I certify that, after reasonable inquiry, the statements in and attached to this Natural Gas Management Plan are true and correct to the best of my knowledge and acknowledge that a false statement may be subject to civil and criminal penalties under the Oil and Gas Act.

Signature: 
Printed Name: Sammy Hajar
Title: Regulatory Analyst
E-mail Address: SHAJAR@BTAOIL.COM
Date: 8/9/2021
Phone: 432-682-3753
OIL CONSERVATION DIVISION (Only applicable when submitted as a standalone form)
Approved By:
Title:
Approval Date:
Conditions of Approval:

VI. Separation Equipment: Attach a complete description of how Operator will size separation equipment to optimize gas capture.

- Separation equipment will be sized to provide adequate separation for anticipated rates.
- Separation equipment will allow for adequate retention time to allow gas and liquids to separate.
- Separation equipment will separate all three phases (Oil, Water, and Gas).
- Collection systems are appropriately sized to handle facility production rates on all (3) phases.
- Ancillary equipment and metering is selected to be serviced without flow interruptions or the need to release gas from the well.

VII. Operational Practices: Attach a complete description of the actions Operator will take to comply with the requirements of Subsection A through F 19.15.27.8 NMAC.

Drilling Operations

- All flare stacks will be properly sized. The flare stacks will be located at a minimum 100' from the nearest surface hole location on the pad.
- All natural gas produced during drilling operations will be flared, unless there is an equipment malfunction and/or to avoid risk of an immediate and substantial adverse impact on safety and the environment, at which point the gas will be vented.

Completions/Recompletions Operations

- New wells will not be flowed back until they are connected to a properly sized gathering system.
- The facility will be built/sized for maximum anticipated flowrates and pressures to minimize waste.
- For flowback operations, multiple stages of separation will be used as well as VRU and blowers to make sure waste is minimized off the storage tanks and facility.
- During initial flowback, the well stream will be routed to separation equipment.
- At an existing facility, when necessary, post separation natural gas will be flared until it meets pipeline specifications, at which point it will be turned into a collection system.
- At a new facility, post separation natural gas will be vented until storage tanks can safely function, at which point it will be flared until it meets pipeline spec.

Production Operations

- Weekly AVOs will be performed on all facilities that produce more than 60 MCFD.
- Leaking thief hatches and pressure safety valves found during AVOs will be cleaned and properly re-sealed.
- All flares will be equipped with auto-ignition systems and continuous pilot operations.
- After a well is stabilized from liquid unloading, the well will be turned back into the collection system.
- All gas lift systems will be optimized to limit the amount of waste.
- All tanks will have automatic gauging equipment installed.

Performance Standards

- Production equipment will be designed to handle maximum anticipated rates and pressure.
- All flared gas will be combusted in a flare stack that is properly sized and designed to ensure proper combustion.
- All gas will have multiple points of separation to ensure no liquids enter flares, combustors, or gas sales line.
- Weekly AVOs will be performed on all wells and facilities that produce more than 60 MCFD.
- All OOOOa facilities will be filmed with an Optical Gas Imaging Thermographer camera once per month to check for fugitive emissions.

Measurement & Estimation

- All volume that is flared and vented that is not measured will be estimated.
- All measurement equipment for flared volumes will conform to API 14.10.
- All meters will be calibrated at regular intervals according to meter manufacturer recommendations.
- When metering is not practical due to low pressure/low rate, the vented or flared volume will be estimated.

VIII. Best Management Practices: Attach a complete description of Operator's best management practices to minimize venting during active and planned maintenance.

- During downhole well maintenance, BTA will use best management practices to vent as minimally as possible.
- Prior to the commencement of any maintenance, the tank or vessel will be isolated from the rest of the facilities.
- All valves upstream of the equipment will be closed and isolated.
- After equipment has been isolated, the equipment will be blown down to as low a pressure as possible into the collection system.
- If the equipment being maintained cannot be relieved into the collection system, it shall be released to a tank where the vapor can either be captured or combusted if possible.
- After downhole well maintenance, natural gas will be flared until it reaches pipeline specification.

District I
 1625 N. French Dr., Hobbs, NM 88240
 Phone:(575) 393-6161 Fax:(575) 393-0720
District II
 811 S. First St., Artesia, NM 88210
 Phone:(575) 748-1283 Fax:(575) 748-9720
District III
 1000 Rio Brazos Rd., Aztec, NM 87410
 Phone:(505) 334-6178 Fax:(505) 334-6170
District IV
 1220 S. St Francis Dr., Santa Fe, NM 87505
 Phone:(505) 476-3470 Fax:(505) 476-3462

State of New Mexico
Energy, Minerals and Natural Resources
Oil Conservation Division
1220 S. St Francis Dr.
Santa Fe, NM 87505

CONDITIONS

Action 40786

CONDITIONS

Operator: BTA OIL PRODUCERS, LLC 104 S Pecos Midland, TX 79701	OGRID: 260297
	Action Number: 40786
	Action Type: [C-101] BLM - Federal/Indian Land Lease (Form 3160-3)

CONDITIONS

Created By	Condition	Condition Date
pkautz	Will require a File As Drilled C-102 and a Directional Survey with the C-104	8/11/2021
pkautz	Once the well is spud, to prevent ground water contamination through whole or partial conduits from the surface, the operator shall drill without interruption through the fresh water zone or zones and shall immediately set in cement the water protection string	8/11/2021