

Form 3160-3
(June 2015)

FORM APPROVED
OMB No. 1004-0137
Expires: January 31, 2018

UNITED STATES
DEPARTMENT OF THE INTERIOR
BUREAU OF LAND MANAGEMENT
APPLICATION FOR PERMIT TO DRILL OR REENTER

1a. Type of work: <input type="checkbox"/> DRILL <input type="checkbox"/> REENTER 1b. Type of Well: <input type="checkbox"/> Oil Well <input type="checkbox"/> Gas Well <input type="checkbox"/> Other 1c. Type of Completion: <input type="checkbox"/> Hydraulic Fracturing <input type="checkbox"/> Single Zone <input type="checkbox"/> Multiple Zone		5. Lease Serial No. 6. If Indian, Allottee or Tribe Name 7. If Unit or CA Agreement, Name and No. 8. Lease Name and Well No.
2. Name of Operator		9. API Well No. 30-025-54455
3a. Address	3b. Phone No. (include area code)	10. Field and Pool, or Exploratory
4. Location of Well (Report location clearly and in accordance with any State requirements. *) At surface At proposed prod. zone		11. Sec., T. R. M. or Blk. and Survey or Area
14. Distance in miles and direction from nearest town or post office*		12. County or Parish
13. State		
15. Distance from proposed* location to nearest property or lease line, ft. (Also to nearest drig. unit line, if any)	16. No of acres in lease	17. Spacing Unit dedicated to this well
18. Distance from proposed location* to nearest well, drilling, completed, applied for, on this lease, ft.	19. Proposed Depth	20. BLM/BIA Bond No. in file
21. Elevations (Show whether DF, KDB, RT, GL, etc.)	22. Approximate date work will start*	23. Estimated duration
24. Attachments		

The following, completed in accordance with the requirements of Onshore Oil and Gas Order No. 1, and the Hydraulic Fracturing rule per 43 CFR 3162.3-3 (as applicable)

- | | |
|---|---|
| 1. Well plat certified by a registered surveyor.
2. A Drilling Plan.
3. A Surface Use Plan (if the location is on National Forest System Lands, the SUPO must be filed with the appropriate Forest Service Office). | 4. Bond to cover the operations unless covered by an existing bond on file (see Item 20 above).
5. Operator certification.
6. Such other site specific information and/or plans as may be requested by the BLM. |
|---|---|

25. Signature	Name (Printed/Typed)	Date
Title		
Approved by (Signature)	Name (Printed/Typed)	Date
Title		Office

Application approval does not warrant or certify that the applicant holds legal or equitable title to those rights in the subject lease which would entitle the applicant to conduct operations thereon.
 Conditions of approval, if any, are attached.

Title 18 U.S.C. Section 1001 and Title 43 U.S.C. Section 1212, make it a crime for any person knowingly and willfully to make to any department or agency of the United States any false, fictitious or fraudulent statements or representations as to any matter within its jurisdiction.



(Continued on page 2)

*(Instructions on page 2)

C-102 Submit Electronically Via OCD Permitting	State of New Mexico Energy, Minerals & Natural Resources Department OIL CONSERVATION DIVISION	Revised July 9, 2024
		Submittal Type: <input checked="" type="checkbox"/> Initial Submittal <input type="checkbox"/> Amended Report <input type="checkbox"/> As Drilled

WELL LOCATION INFORMATION

API Number 30-025-54455	Pool Code 28432	Pool Name Grama Ridge; Bone Spring West
Property Code 337076	Property Name WEST GRAMA RIDGE 8-5 FEDERAL COM	Well Number 153H
OGRID No. 215099	Operator Name CIMAREX ENERGY CO.	Ground Level Elevation 3525.5'
Surface Owner: <input type="checkbox"/> State <input type="checkbox"/> Fee <input type="checkbox"/> Tribal <input type="checkbox"/> Federal		Mineral Owner: <input type="checkbox"/> State <input type="checkbox"/> Fee <input type="checkbox"/> Tribal <input checked="" type="checkbox"/> Federal

Surface Location

UL M	Section	Township	Range	Lot	Ft. from N/S	Ft. from E/W	Latitude (NAD 83)	Longitude (NAD 83)	County
	8	22S	34E		397 SOUTH	560 WEST	32.400061°	-103.498776°	LEA

Bottom Hole Location

UL	Section	Township	Range	Lot	Ft. from N/S	Ft. from E/W	Latitude (NAD 83)	Longitude (NAD 83)	County
4	5	22S	34E		100 NORTH	770 WEST	32.427769°	-103.498033°	LEA

Dedicated Acres 320.46	Infill or Defining Well	Defining Well API	Overlapping Spacing Unit (Y/N)	Consolidation Code
Order Numbers.		Well setbacks are under Common Ownership: <input type="checkbox"/> Yes <input type="checkbox"/> No		

Kick Off Point (KOP)

UL M	Section	Township	Range	Lot	Ft. from N/S	Ft. from E/W	Latitude (NAD 83)	Longitude (NAD 83)	County
	8	22S	34E		100 SOUTH	770 WEST	32.399246°	-103.498099°	LEA

First Take Point (FTP)

UL M	Section	Township	Range	Lot	Ft. from N/S	Ft. from E/W	Latitude (NAD 83)	Longitude (NAD 83)	County
	8	22S	34E		100 SOUTH	770 WEST	32.399246°	-103.498099°	LEA

Last Take Point (LTP)

UL	Section	Township	Range	Lot	Ft. from N/S	Ft. from E/W	Latitude (NAD 83)	Longitude (NAD 83)	County
4	5	22S	34E		100 NORTH	770 WEST	32.427769°	-103.498033°	LEA

Unitized Area or Area of Uniform Interest	Spacing Unit Type <input type="checkbox"/> Horizontal <input type="checkbox"/> Vertical	Ground Floor Elevation:
---	---	-------------------------

<p>OPERATOR CERTIFICATIONS</p> <p><i>I hereby certify that the information contained herein is true and complete to the best of my knowledge and belief, and, if the well is a vertical or directional well, that this organization either owns a working interest or unleased mineral interest in the land including the proposed bottom hole location or has a right to drill this well at this location pursuant to a contract with an owner of a working interest or unleased mineral interest, or to a voluntary pooling agreement or a compulsory pooling order heretofore entered by the division.</i></p> <p><i>If this well is a horizontal well, I further certify that this organization has received the consent of at least one lessee or owner of a working interest or unleased mineral interest in each tract (in the target pool or formation) in which any part of the well's completed interval will be located or obtained a compulsory pooling order from the division.</i></p> <p><i>Shelly Bowen</i> 8/26/2024</p>	<p>SURVEYOR CERTIFICATIONS</p> <p><i>I hereby certify that the well location shown on this plat was plotted from the field notes of actual surveys made by me or under my supervision, and that the same is true and correct to the best of my belief.</i></p> <div style="text-align: center;">  </div>
Signature _____ Date _____	Signature and Seal of Professional Surveyor _____
Shelly Bowen	23782 March 21, 2024
Printed Name _____	Certificate Number _____ Date of Survey _____
shelly.bowen@coterra.com	
Email Address _____	

Note: No allowable will be assigned to this completion until all interest have been consolidated or a non-standard unit has been approved by the division.

Property Name WEST GRAMA RIDGE 8-5 FEDERAL COM	Well Number 153H	Drawn By Z.L. 03-25-24	Revised By REV. 4 T.I.R. 08-07-24 (UPDATE FORMAT & ADD ACREAGE)
---	---------------------	---------------------------	--

NAD 83 (SURFACE HOLE LOCATION)
LATITUDE = 32°24'00.22" (32.400061°)
LONGITUDE = -103°29'55.59" (-103.498776°)
NAD 27 (SURFACE HOLE LOCATION)
LATITUDE = 32°23'59.78" (32.399938°)
LONGITUDE = -103°29'53.86" (-103.498293°)
STATE PLANE NAD 83 (N.M. EAST)
N: 510278.90' E: 798914.64'
STATE PLANE NAD 27 (N.M. EAST)
N: 510218.21' E: 757731.96'

NAD 83 (KOP/LP/FTP)
LATITUDE = 32°23'57.29" (32.399246°)
LONGITUDE = -103°29'53.16" (-103.498099°)
NAD 27 (KOP/LP/FTP)
LATITUDE = 32°23'56.84" (32.399122°)
LONGITUDE = -103°29'51.42" (-103.497616°)
STATE PLANE NAD 83 (N.M. EAST)
N: 509983.85' E: 799125.98'
STATE PLANE NAD 27 (N.M. EAST)
N: 509923.16' E: 757943.29'

NAD 83 (LPP)
LATITUDE = 32°24'48.53" (32.413481°)
LONGITUDE = -103°29'53.04" (-103.498066°)
NAD 27 (LPP)
LATITUDE = 32°24'48.09" (32.413357°)
LONGITUDE = -103°29'51.30" (-103.497583°)
STATE PLANE NAD 83 (N.M. EAST)
N: 515162.84' E: 799095.71'
STATE PLANE NAD 27 (N.M. EAST)
N: 515102.00' E: 757913.12'

NAD 83 (LTP/BHL)
LATITUDE = 32°25'39.97" (32.427769°)
LONGITUDE = -103°29'52.92" (-103.498033°)
NAD 27 (LTP/BHL)
LATITUDE = 32°25'39.52" (32.427645°)
LONGITUDE = -103°29'51.18" (-103.497549°)
STATE PLANE NAD 83 (N.M. EAST)
N: 520360.99' E: 799065.31'
STATE PLANE NAD 27 (N.M. EAST)
N: 520299.98' E: 757882.84'

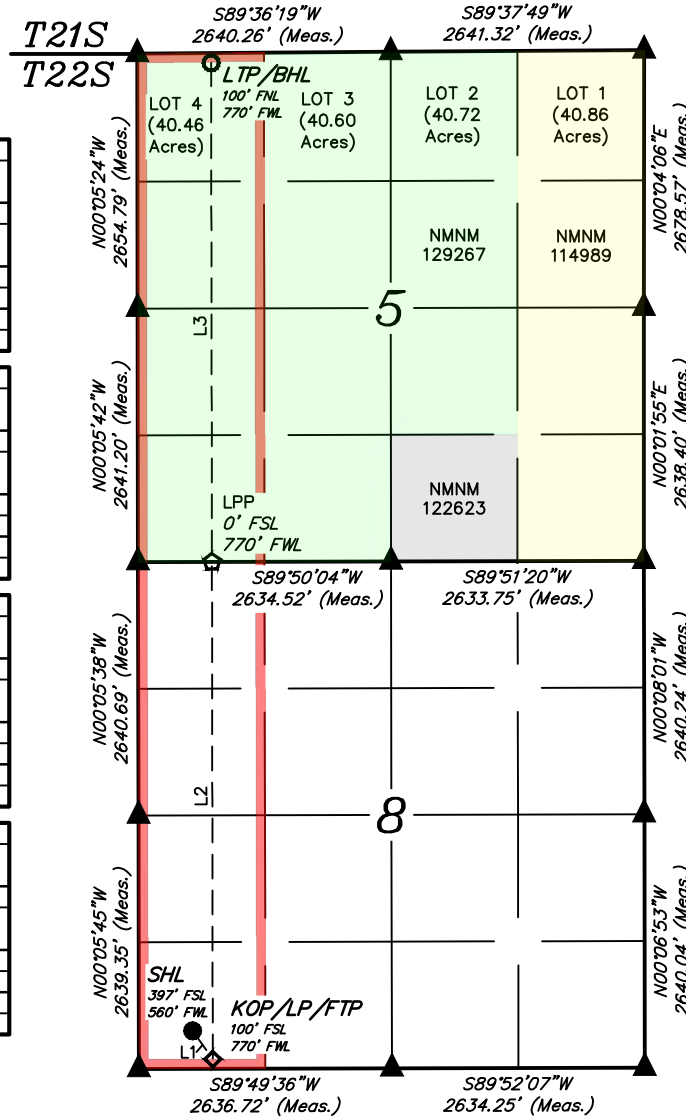

LINE TABLE		
LINE	DIRECTION	LENGTH
L1	S35°22'18"E	363.00'
L2	N00°05'37"W	5179.93'
L3	N00°05'37"W	5199.08'

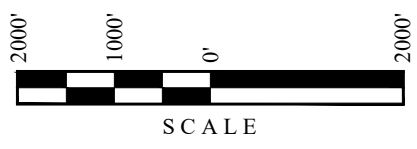

- NOTE:**
- Distances referenced on plat to section lines are perpendicular.
 - Basis of Bearings is a Transverse Mercator Projection with a Central Meridian of W103°53'00" (NAD 83)
 - Colored areas within section lines represent oil & gas leases.

- = SURFACE HOLE LOCATION
- ◆ = KICK OFF POINT/LANDING POINT/FIRST TAKE POINT
- ⬠ = LEASE PENETRATION POINT
- ⊙ = LAST TAKE POINT/BOTTOM HOLE LOCATION
- ▲ = SECTION CORNER LOCATED
- = HORIZONTAL SPACING UNIT

State of New Mexico
 Energy, Minerals and Natural Resources Department

Submit Electronically
 Via E-permitting

Oil Conservation Division
 1220 South St. Francis Dr.
 Santa Fe, NM 87505

NATURAL GAS MANAGEMENT PLAN

This Natural Gas Management Plan must be submitted with each Application for Permit to Drill (APD) for a new or recompleted well.

Section 1 – Plan Description Effective May 25, 2021

I. Operator: Cimarex Energy Co. **OGRID:** 215099 **Date:** 6/19/24

II. Type: Original Amendment due to 19.15.27.9.D(6)(a) NMAC 19.15.27.9.D(6)(b) NMAC Other.

If Other, please describe: _____

III. Well(s): Provide the following information for each new or recompleted well or set of wells proposed to be drilled or proposed to be recompleted from a single well pad or connected to a central delivery point.

Well Name	API	ULSTR	Footages	Anticipated Oil BBL/D	Anticipated Gas MCF/D	Anticipated Produced Water BBL/D
West Grama Ridge 8-5 Fed Com	153H	SW\$W Sec 8 T22S, R34E	397 FSL/ 560FWL	1250	2931	3000

IV. Central Delivery Point Name: West Grama CTB _____ [See 19.15.27.9(D)(1) NMAC]

V. Anticipated Schedule: Provide the following information for each new or recompleted well or set of wells proposed to be drilled or proposed to be recompleted from a single well pad or connected to a central delivery point.

Well Name	API	Spud Date	TD Reached Date	Completion Commencement Date	Initial Flow Back Date	First Production Date
West Grama Ridge 8-5 Fed Com	153H	8/7/2026	10/1/26	12/25/2026	1/15/27	2/15/27

VI. Separation Equipment: Attach a complete description of how Operator will size separation equipment to optimize gas capture.

VII. Operational Practices: Attach a complete description of the actions Operator will take to comply with the requirements of Subsection A through F of 19.15.27.8 NMAC.

VIII. Best Management Practices: Attach a complete description of Operator's best management practices to minimize venting during active and planned maintenance.

Section 2 – Enhanced Plan

EFFECTIVE APRIL 1, 2022

Beginning April 1, 2022, an operator that is not in compliance with its statewide natural gas capture requirement for the applicable reporting area must complete this section.

Operator certifies that it is not required to complete this section because Operator is in compliance with its statewide natural gas capture requirement for the applicable reporting area.

IX. Anticipated Natural Gas Production:

Well	API	Anticipated Average Natural Gas Rate MCF/D	Anticipated Volume of Natural Gas for the First Year MCF

X. Natural Gas Gathering System (NGGS):

Operator	System	ULSTR of Tie-in	Anticipated Gathering Start Date	Available Maximum Daily Capacity of System Segment Tie-in

XI. Map. Attach an accurate and legible map depicting the location of the well(s), the anticipated pipeline route(s) connecting the production operations to the existing or planned interconnect of the natural gas gathering system(s), and the maximum daily capacity of the segment or portion of the natural gas gathering system(s) to which the well(s) will be connected.

XII. Line Capacity. The natural gas gathering system will will not have capacity to gather 100% of the anticipated natural gas production volume from the well prior to the date of first production.

XIII. Line Pressure. Operator does does not anticipate that its existing well(s) connected to the same segment, or portion, of the natural gas gathering system(s) described above will continue to meet anticipated increases in line pressure caused by the new well(s).

Attach Operator’s plan to manage production in response to the increased line pressure.

XIV. Confidentiality: Operator asserts confidentiality pursuant to Section 71-2-8 NMSA 1978 for the information provided in Section 2 as provided in Paragraph (2) of Subsection D of 19.15.27.9 NMAC, and attaches a full description of the specific information for which confidentiality is asserted and the basis for such assertion.

Section 3 - Certifications

Effective May 25, 2021

Operator certifies that, after reasonable inquiry and based on the available information at the time of submittal:

Operator will be able to connect the well(s) to a natural gas gathering system in the general area with sufficient capacity to transport one hundred percent of the anticipated volume of natural gas produced from the well(s) commencing on the date of first production, taking into account the current and anticipated volumes of produced natural gas from other wells connected to the pipeline gathering system; or

Operator will not be able to connect to a natural gas gathering system in the general area with sufficient capacity to transport one hundred percent of the anticipated volume of natural gas produced from the well(s) commencing on the date of first production, taking into account the current and anticipated volumes of produced natural gas from other wells connected to the pipeline gathering system.

If Operator checks this box, Operator will select one of the following:

Well Shut-In. Operator will shut-in and not produce the well until it submits the certification required by Paragraph (4) of Subsection D of 19.15.27.9 NMAC; or

Venting and Flaring Plan. Operator has attached a venting and flaring plan that evaluates and selects one or more of the potential alternative beneficial uses for the natural gas until a natural gas gathering system is available, including:

- (a) power generation on lease;
- (b) power generation for grid;
- (c) compression on lease;
- (d) liquids removal on lease;
- (e) reinjection for underground storage;
- (f) reinjection for temporary storage;
- (g) reinjection for enhanced oil recovery;
- (h) fuel cell production; and
- (i) other alternative beneficial uses approved by the division.

Section 4 - Notices

1. If, at any time after Operator submits this Natural Gas Management Plan and before the well is spud:

(a) Operator becomes aware that the natural gas gathering system it planned to connect the well(s) to has become unavailable or will not have capacity to transport one hundred percent of the production from the well(s), no later than 20 days after becoming aware of such information, Operator shall submit for OCD's approval a new or revised venting and flaring plan containing the information specified in Paragraph (5) of Subsection D of 19.15.27.9 NMAC; or

(b) Operator becomes aware that it has, cumulatively for the year, become out of compliance with its baseline natural gas capture rate or natural gas capture requirement, no later than 20 days after becoming aware of such information, Operator shall submit for OCD's approval a new or revised Natural Gas Management Plan for each well it plans to spud during the next 90 days containing the information specified in Paragraph (2) of Subsection D of 19.15.27.9 NMAC, and shall file an update for each Natural Gas Management Plan until Operator is back in compliance with its baseline natural gas capture rate or natural gas capture requirement.

2. OCD may deny or conditionally approve an APD if Operator does not make a certification, fails to submit an adequate venting and flaring plan which includes alternative beneficial uses for the anticipated volume of natural gas produced, or if OCD determines that Operator will not have adequate natural gas takeaway capacity at the time a well will be spud.

I certify that, after reasonable inquiry, the statements in and attached to this Natural Gas Management Plan are true and correct to the best of my knowledge and acknowledge that a false statement may be subject to civil and criminal penalties under the Oil and Gas Act.

Signature:	<i>Shelly Bowen</i>
Printed Name:	<input type="text" value="Shelly Bowen"/>
Title:	<input type="text" value="Sr. Regulatory Analyst"/>
E-mail Address:	<input type="text" value="shelly.bowen@coterra.com"/>
Date:	6/19/24
Phone:	<input type="text" value="432/620-1644"/>

OIL CONSERVATION DIVISION
(Only applicable when submitted as a standalone form)

Approved By:
Title:
Approval Date:
Conditions of Approval:

From State of New Mexico, Natural Gas Management Plan

VI. Separation Equipment: Attach a complete description of how Operator will size separation equipment to optimize gas capture.

XEC Standard Response

Standard facility gas process flow begins at the inlet separator. These vessels are designed based off of forecasted rates and residence times in accordance with, and often greater than, API 12J. The separated gas is then routed to an additional separation vessel (ie sales scrubber) in order to extract liquids that may have carried over or developed due to the decrease in pressure. The sales scrubber is sized based on API 521. From the sales scrubber, the gas leaves the facility and enters the gas midstream gathering network.

Cimarex

VII. Operational Practices

Cimarex values the sustainable development of New Mexico's natural resources. Venting and flaring of natural gas is a source of waste in the industry, and Cimarex will ensure that its values are aligned with those of NMOCD. As such, Cimarex plans to take pointed steps to ensure compliance with Subsection A through F of 19.15.27.8 NMAC.

Specifically, below are the steps Cimarex will plan to follow under routine well commissioning and operations.

1. Capture or combust natural gas during drilling operations where technically feasible, using the best industry practices and control technologies.
 - a. All flares during these operations will be a minimum of 100ft away from the nearest surface-hole location.
2. All gas present during post-completion drill-out and flow back will be routed through separation equipment, and, if technically feasible, flare unsellable vapors rather than vent. Lastly, formal sales separator commissioning to process well-stream fluids and send gas to a gas flow line/collection system or use the gas for on-site fuel or beneficial usage, gas as soon as is safe and technically feasible.
3. Cimarex will ensure the flare or combustion equipment is properly sized to handle expected flow rates, ensure this equipment is equipped with an automatic or continuous ignition source, and ensure this equipment is designed for proper combustion efficiency.
4. If Cimarex must flare because gas is not meeting pipeline specifications, Cimarex will limit flaring to <60 days, analyze gas composition at least twice per week, and route gas into a gathering pipeline as soon as pipeline specifications are met.
5. Under routine production operations, Cimarex will not flare/vent unless:
 - a. Venting or flaring occurs due to an emergency or equipment malfunction.
 - b. Venting or flaring occurs as a result of unloading practices, and an operator is onsite (or within 30 minutes of drive time and posts contact information at the wellsite) until the end of unloading practice.
 - c. The venting or flaring occurs during automated plungerlift operations, in which case the Cimarex operator will work to optimize the plungerlift system to minimize venting/flaring.
 - d. The venting or flaring occurs during downhole well maintenance, in which case Cimarex will work to minimize venting or flaring operations to the extent that it does not pose a risk to safe operations.
 - e. The well is an exploratory well, the division has approved the well as an exploratory well, venting or flaring is limited to 12 months, as approved by the division, and venting/flaring does not cause Cimarex to breach its State-wide 98% gas capture requirement.
 - f. Venting or flaring occurs because the stock tanks or other low-pressure vessels are being gauged, sampled, or liquids are being loaded out.
 - g. The venting or flaring occurs because pressurized vessels are being maintained and are being blown-down or depressurized.
 - h. Venting or flaring occurs as a result of normal dehydration unit operations.

- i. Venting or flaring occurs as a result of bradenhead testing.
 - j. Venting or flaring occurs as a result of normal compressor operations, including general compressor operations, compressor engines and turbines.
 - k. Venting or flaring occurs as a result of a packer leakage test.
 - l. Venting or flaring occurs as a result of a production test lasting less than 24 hours unless otherwise approved by the division.
 - m. Venting or flaring occurs as a result of new equipment commissioning and is necessary to purge impurities from the pipeline or production equipment.
6. Cimarex will maintain its equipment in accordance with its Operations and Maintenance Program, to ensure venting or flaring events are minimized and that equipment is properly functioning.
7. Cimarex will install automatic tank gauging equipment on all production facilities constructed after May 25, 2021, to ensure minimal emissions from tank gauging practices.
8. By November 25, 2022, all Cimarex facilities equipped with flares or combustors will be equipped with continuous pilots or automatic igniters, and technology to ensure proper function, i.e. thermocouple, fire-eye, etc...
9. Cimarex will perform AVO (audio, visual, olfactory) facility inspections in accordance with NMOCD requirements. Specifically, Cimarex will:
 - a. Perform weekly inspections during the first year of production, and so long as production is greater than 60 MCFD.
 - b. If production is less than 60 MCFD, Cimarex will perform weekly AVO inspections when an operator is present on location, and inspections at least once per calendar month with at least 20 calendar days between inspections.
10. Cimarex will measure or estimate the volume of vented, flared or beneficially used natural gas, regardless of the reason or authorization for such venting or flaring.
11. On all facilities constructed after May 25, 2021, Cimarex will install metering where feasible and in accordance with available technology and best engineering practices, in an effort to measure how much gas could have been vented or flared.
 - a. In areas where metering is not technically feasible, such as low-pressure/low volume venting or flaring applications, engineering estimates will be used such that the methodology could be independently verified.
12. Cimarex will fulfill the division's requirements for reporting and filing of venting or flaring that exceeds 50 MCF in volume or last eight hours or more cumulatively within any 24-hour period.

VIII. Best Management Practices to minimize venting during active and planned maintenance

Cimarex strives to ensure minimal venting occurs during active and planned maintenance activities. Below is a description of common maintenance practices, and the steps Cimarex takes to limit venting exposure.

- **Workovers:**
 - Always strive to kill well when performing downhole maintenance.
 - If vapors or trapped pressure is present and must be relieved then:
 - Initial blowdown to production facility:
 - Route vapors to LP flare if possible/applicable
 - Blowdown to portable gas buster tank:
 - Vent to existing or portable flare if applicable.

- **Stock tank servicing:**
 - Minimize time spent with thief hatches open.
 - When cleaning or servicing via manway, suck tank bottoms to ensure minimal volatiles exposed to atmosphere.
 - Connect vacuum truck to low pressure flare while cleaning bottoms to limit venting.
 - Isolate the vent lines and overflows on the tank being serviced from other tanks.

- **Pressure vessel/compressor servicing and associated blowdowns:**
 - Route to flare where possible.
 - Blow vessel down to minimum available pressure via pipeline, prior to venting vessel.
 - Preemptively changing anodes to reduce failures and extended corrosion related servicing.
 - When cleaning or servicing via manway, suck vessel bottoms to ensure minimal volatiles exposed to atmosphere.

- **Flare/combustor maintenance:**
 - Minimize downtime by coordinating with vendor and Cimarex staff travel logistics.
 - Utilizing preventative and predictive maintenance programs to replace high wear components before failure.
 - Because the flare/combustor is the primary equipment used to limit venting practices, ensure flare/combustor is properly maintained and fully operational at all times via routine maintenance, temperature telemetry, onsite visual inspections.

The Cimarex expectation is to limit all venting exposure. Equipment that may not be listed on this document is still expected to be maintained and associated venting during such maintenance minimized.

Standard New Mexico Variances

Variance Request #1: Skid Rig after Cementing Surface Casing

Coterra requests permission to skid the rig to the next well on the pad in order to begin operations immediately after the cement job for the surface casing has been completed. After the cement job is completed, no operations on the subject well will be conducted until at least 8 hours have elapsed, and both lead and tail slurries have achieved 500 psi compressive strength. While cement cures, the surface casing of the subject well will be suspended in the well by a mandrel and landing ring system, which is independent from the rig and ensures that casing remains centered while the rig is active on other wells. Before skidding the rig, a TA cap is installed on the subject well.

Variance Request #4: Utilize Co-Flex Choke Line

Coterra requests approval to utilize a co-flex choke line between the BOP and choke manifold. Certification for the proposed co-flex choke line is attached. The choke line is not required by the manufacturer to be anchored. In the event the specific co-flex choke line is not available, one of equal or higher rating will be used. Variance to include Hammer Union connections on lines downstream of the buffer tank only.

1. Geological Formations

TVD of target 10,200
MD at TD 20,037

Pilot Hole TD N/A
Deepest expected fresh water

Formation	Depth (TVD) from KB	Water/Mineral Bearing/Target Zone	Hazards
Rustler	1655	N/A	
A3 Top	1720	N/A	
A3 Base	1840	N/A	
Top of Salt	2110	N/A	
Base of Salt/Lamar	5160	N/A	
Bell Canyon	5210	Hydrocarbons	
Cherry Canyon	5860	Hydrocarbons	
Brushy Canyon	7090	Hydrocarbons	
Basal Brushy Canyon	8400	N/A	
Bone Spring Lime	8630	N/A	
Leonar/Avalon Sand	8795	Hydrocarbons	
Avalon Shale	8950	Hydrocarbons	
1st Bone Spring Sand	9720	Hydrocarbons	
1st Bone Spring Sand - Target	9900	Hydrocarbons	

2. Casing Program

Hole Size	Casing Depth From	Casing Depth To	Setting Depth TVD	Casing Size	Weight (lb/ft)	Grade	Conn.	SF Collapse	SF Burst	SF Tension	
17 1/2	0	1720	1720	13-3/8"	54.50	J-55	BT&C	1.52	3.68	9.10	
12 1/4	0	5207	5190	9-5/8"	40.00	HCK-55	LT&C	1.41	1.46	2.70	
8 3/4	0	9326	9326	7"							
8 3/4	9326	10076	9861	7"	29.00	P-110	BT&C	1.75	2.30	59.88	
6	9126	20037	10200	4-1/2"	11.60	L-80	BT&C	1.26	1.54	21.43	
BLM Minimum Safety Factor								1.125	1	1.6 Dry 1.8 Wet	

TVD was used on all calculations.

All casing strings will be tested in accordance with Onshore Oil and Gas Order #2 III.B.1.h

Cimarex Energy Co., West Grama Ridge 8-5 Federal Com 153H

	Y or N
Is casing new? If used, attach certification as required in Onshore Order #1	Y
Does casing meet API specifications? If no, attach casing specification sheet.	Y
Is premium or uncommon casing planned? If yes attach casing specification sheet.	N
Does the above casing design meet or exceed BLM's minimum standards? If not provide justification (loading assumptions, casing design criteria).	Y
Will the intermediate pipe be kept at a minimum 1/3 fluid filled to avoid approaching the collapse pressure rating of the casing?	Y
Is well located within Capitan Reef?	N
If yes, does production casing cement tie back a minimum of 50' above the Reef?	N
Is well within the designated 4 string boundary.	N
Is well located in SOPA but not in R-111-P?	N
If yes, are the first 2 strings cemented to surface and 3rd string cement tied back 500' into previous casing?	N
Is well located in R-111-P and SOPA?	N
If yes, are the first three strings cemented to surface?	N
Is 2nd string set 100' to 600' below the base of salt?	N
Is well located in high Cave/Karst?	N
If yes, are there two strings cemented to surface?	N
(For 2 string wells) If yes, is there a contingency casing if lost circulation occurs?	N
Is well located in critical Cave/Karst?	N
If yes, are there three strings cemented to surface?	N
Is AC Report included?	Y

3. Cementing Program

Casing	# Sk	Wt. lb/gal	Yld ft3/sack	H2O gal/sk	500# Comp. Strength (hours)	Slurry Description
Surface	834	13.50	1.72	9.15	15.5	Lead: Class C + Bentonite
	223	14.80	1.34	6.32	9.5	Tail: Class C + LCM
Intermediate	954	12.90	1.88	9.65	12	Lead: 35:65 (Poz:C) + Salt + Bentonite
	292	14.80	1.34	6.32	9.5	Tail: Class C + LCM
Production	265	10.30	3.64	22.18		Lead: Tuned Light + LCM
	125	14.80	1.36	6.57	9.5	Tail: Class C + Retarder
Completion System	739	14.20	1.30	5.86	14:30	Tail: 50:50 (Poz:H) + Salt + Bentonite + Fluid Loss + Dispersant + SMS

Casing String	TOC	% Excess
Surface	0	45
Intermediate	0	51
Production	5007	25
Completion System	9876	10

Cimarex request the ability to perform casing integrity tests after plug bump of cement job.

4. Pressure Control Equipment

A variance is requested for the use of a diverter on the surface casing. See attached for schematic.					
BOP installed and tested before drilling which hole?	Size	Min Required WP	Type		Tested To
12 1/4	13 5/8	5M	Annular	5M	100% of working pressure
			Blind Ram		5M
			Pipe Ram	X	
			Double Ram	X	
			Other		
8 3/4	13 5/8	5M	Annular	5M	100% of working pressure
			Blind Ram		5M
			Pipe Ram	X	
			Double Ram	X	
			Other		
6	13 5/8	5M	Annular	5M	100% of working pressure
			Blind Ram		5M
			Pipe Ram	X	
			Double Ram	X	
			Other		

X	Formation integrity test will be performed per Onshore Order #2. On Exploratory wells or on that portion of any well approved for a 5M BOPE system or greater, a pressure integrity test of each casing shoe shall be performed. Will be tested in accordance with Onshore Oil and Gas Order #2 III.B.1.i.
X	A variance is requested for the use of a flexible choke line from the BOP to Choke Manifold. See attached for specs and hydrostatic test chart.
N	Are anchors required by manufacturer?

5. Mud Program

Depth	Type	Weight (ppg)	Viscosity	Water Loss
0' to 1720'	Fresh Water	7.83 - 8.33	28	N/C
1720' to 5207'	Brine Water	9.50 - 10.00	30-32	N/C
5207' to 10076'	Cut Brine or OBM	9.00 - 9.50	27-70	N/C
10341' to 20037'	OBM	9.00 - 9.50	50-70	N/C

Sufficient mud materials to maintain mud properties and meet minimum lost circulation and weight increase requirements will be kept on location at all times.

What will be used to monitor the loss or gain of fluid?	PVT/Pason/Visual Monitoring
---	-----------------------------

6. Logging and Testing Procedures

Logging, Coring and Testing	
	Will run GR/CNL from TD to surface (horizontal well – vertical portion of hole). Stated logs run will be in the Completion Report and submitted to the BLM.
X	No logs are planned based on well control or offset log information.
	Drill stem test?
	Coring?

Additional Logs Planned	Interval

7. Drilling Conditions

Condition	
BH Pressure at deepest TVD	5038 psi
Abnormal Temperature	No

Hydrogen Sulfide (H2S) monitors will be installed prior to drilling out the surface shoe. If H2S is detected in concentrations greater than 100 ppm, the operator will comply with the provisions of Onshore Oil and Gas Order #6. If Hydrogen Sulfide is encountered, measured values and formations will be provided to the BLM.	
X	H2S is present
X	H2S plan is attached

8. Other Facets of Operation

9. Wellhead

BOPE Additional Information & Testing

- After running the first string of casing, a 5M BOP/BOPE system with 5M annular will be installed. BOPs will be tested according to Onshore Order #2. BOPE will be tested to full rated pressure (5K for all BOPE, including the annular). For the low test, the system will be tested to 250 psi.
- All BOP equipment will be tested utilizing a conventional test plug.
- A remote kill line is included in the BOPE system
- All casing strings will be tested per Onshore Order #2, to 0.22 psi/ft or 1,500 psi, whichever is greater, not to exceed 70% of casing burst.
- If well conditions dictate, conventional slips will be set and BOPE will be tested to appropriate pressures based on permitted pressure requirements.

Wellhead

- The multi-bowl wellhead will be installed by a vendor representative. A copy of the installation instructions has been sent to the BLM field office.
- A packoff will be installed after running and cementing the production casing. This packoff will be tested to 5K psi.

Additional Well Control Notes

- In the event wellbore pressure encroaches to the maximum rated pressure of the annular, primary pressure control will be switched to the higher rated components (i.e., switch from annular to pipe rams) upper pipe rams will be closed, and the annular opened in order to not exceed maximum rated pressures.

Coterra: Well Control Plan



Well Control Plan

Warning Signs of a Kick

If a kick is ever suspected, perform flow check.

While Drilling:

1. Drilling break or increase in penetration rate
2. Increase of flow
3. Pit gain
4. Flow without pumping
5. Circulating pressure decrease and/or spm increase
6. Increase in gas cutting at the shakers
7. Decrease in cuttings at shakers

While Tripping:

1. Hole not taking the proper fill on trip out of hole
2. Hole returns too much mud on trip in hole
3. Flow without pumping

While Out of the Hole:

1. Flow
2. Pit gain

Well Control Procedures with Diverter

A TIW valve in the open position must be on the rig floor at all times.

If rotating head is installed:

1. Perform flow check.
2. If well is flowing, divert flow down flow line and through separator, before returning across shakers.
3. Swap to 10 ppg brine and circulate around. Notify superintendent.

Coterra: Well Control Plan

4. If well becomes uncontrollable, close annular, which will open HCR to divert flow away from rig.

If rotating head is not installed:

1. Perform flow check.
2. If well is flowing uncontrollably, close annular, which will open HCR to divert flow away from rig.
3. Swap to 10 ppg brine and circulate around. Notify superintendent.
4. After 10 ppg is circulated around shut pumps off and perform flow check.

Well Control Procedures

Coterra follows a hard shut-in procedure. Choke will be in the closed position.

General Well Control

1. If in doubt, secure the well first, then inform your supervisor.
2. Never wait for approval to shut in the well.
3. Verify that the mud pump is off before you close the BOP.
4. Always check and verify the well is properly secured after shut in.
5. Always install TIW valve in the open position.
6. If TIW valve is installed and then closed, apply estimated DP shut-in pressure above valve before opening.
7. The weak link in the mud system and mud lines is the pressure relief valve or pop off valve on the mud pump.
8. Keep the TIW valve wrench in a designated location on the rig floor and in the open position.
9. Use a drill string float above the bit. Don't perforate or disable the float.
10. In the event wellbore pressure encroaches to the maximum rated pressure of the annular, primary pressure control will be switched to the higher rated components (i.e., switch from annular to pipe rams) – upper pipe rams will be closed, and the annular opened in order to not exceed maximum rated pressures.

Hard Shut-In

1. Remote choke is closed.
2. Stop pumping and space out.
3. Check for flow.
4. To shut in, close annular or pipe ram if no annular is present.
5. Open the HCR valve.
6. Check systems, bump float. Record Initial Shut in Drill pipe pressure and Initial shut in casing pressure.

Coterra: Well Control Plan

Flow Check when on Bottom

1. Alert crew & stop rotating
2. Pick up and space out
3. Shut down pumps
4. Observe well for flow
5. Shut-in if flowing

Shutting in while Drilling

1. After flow has been detected via flow check, kill pumps, shut in well and open HCR
2. Verify well is shut-in and flow has stopped
3. Notify supervisory personnel
4. Record data
5. Begin go forward planning

Flow Check while Tripping

1. Alert crew & pick up / space out
2. Stop pipe movement. Set slips with tool joint accessible at rotary table
3. Install open TIW safety valve and close valve
4. Observe well for flow
5. Shut-in if flowing

Shutting in while Tripping

1. Install open TIW safety valve and close valve
2. Shut-in the well
3. Verify well is shut-in and flow has stopped
4. Install IBOP
5. Notify supervisory personnel
6. Record data; SICP, shut-in time, kick depth, and pit gain
7. Begin go forward planning

Shutting in while Out of Hole

1. Sound alarm
2. Shut-in well: close blind rams.
3. Verify well is shut-in and monitor pressures.
4. Notify supervisory personnel
5. Record data; SICP, shut-in time, kick depth, and pit gain
6. Begin go forward planning

Information to Record while Shut-In

1. Shut in drill pipe pressure every 5 minutes

Coterra: Well Control Plan

2. Shut in casing pressure every 5 minutes
3. Pit gain
4. Total volume in pit system
5. Mud weight in suction pit
6. Current depth
7. Total depth
8. Time the well is shut in

H2S with Annular Diverter:

1. Kill Pumps, close annular, which will open HCR, to divert flow away from rig.
2. Muster and take head count.
3. Call ASSI to check location for H2S. Call Coterra superintendent.
4. After ASSI has checked for H2S the path forward will be decided from Coterra superintendent.

H2S with BOP's:

1. Kill pumps
2. Shut in annular with HCR open and chokes closed.
3. Muster and take head count.
4. Call ASSI to check location for H2S. Call Coterra superintendent.
5. After ASSI has checked for H2S. discuss path forward with Coterra superintendent

Procedure for Closing Blind Rams

- Open HCR valve (visually check that the HCR valve is open – stem in the valve is open, stem out the valve is closed).
- Verify all circulating pumps are off (mud pumps, trip tank pump, etc.)
- Ensure that the hydraulic choke is in the closed position.
- Close the blind rams and place the “blind rams closed, bleed pressure and remove hole cover before opening” sign on the console.
- Monitor the shut in casing pressure gauge periodically while the blinds are closed to ensure that wellbore pressure isn't building. If pressure build up is observed, monitor the shut in casing pressure more frequently & document. Notify rig management and Coterra representative of the pressure build up.
- Ensure that the inner bushings are locked into the master bushings if applicable.
- Install hole cover.

Procedure for Opening Blind Rams

- Make sure choke manifold is aligned correctly.
- Open the hydraulic choke to bleed any trapped pressure that may be under the blind rams. (Even if the casing pressure gauge is reading zero).

Coterra: Well Control Plan

- Confirm that no flow is discharging into the trip tank or possum bellies of the shale shaker (wherever the separator is discharging into).
- Remove hole cover.
- Confirm that the inner bushing are locked into the master bushings if applicable.
- Clear all personnel from the rig floor.
- Remove sign and open blind rams.
- Return the BOPE to its original operating alignment.

BOP Drills

- Drilling crews should conduct BOP drills weekly from BOP nipple up to TD for reaction time to properly simulate securing the well. Record BOP drills on that day's report.
- Standard precautions such as checking the accumulator for proper working pressure, function testing rams, and recording slow pump rates are performed on a daily basis or on trips..
- All supervisory personnel onsite need to be properly trained and currently hold certification from an approved blowout prevention school. Any deviation from this needs to be discussed prior to spud.
- Drillers should always notify the tool pusher and the drilling foreman before performing a blowout drill.

Choke Manifold Freeze Prevention

- When possible, blow out the choke & kill lines as well as the choke manifold with rig air to remove water based fluids.
- When clear water is being placed into the choke & kill line as well as the choke manifold, make sure that the water has a mixture of 30% methanol added.
- When applicable, choke & kill lines as well as choke manifold needs to be pumped through with the rig pump by the driller to ensure that the lines aren't plugged with settling barite or solids.



Borehole: West Grama Ridge 8-5 Federal Com 153H	Well: West Grama Ridge 8-5 Federal Com 153H	Field: NM Lea County (NAD 83)	Structure: Coterra - West Grama Ridge 8-5 Federal Com Pads
---	---	---	--

Gravity & Magnetic Parameters	Surface Location	NAD83 New Mexico State Plane, Eastern Zone, US Feet	Miscellaneous
Model: HDGM 2024 MagDec: 6.192°	Dip: 59.98° FS: 47446.377nT	Date: 16-Aug-2024 Gravity FS: 998.476mgn (9.80665 Based)	Lat: N 32 24 0.22 Lon: W 103 29 55.59
	Northing: 510278.9ftUS Easting: 798914.64ftUS	Grid Conv: 0.4472° Scale Fact: 0.99998507	Slot: West Grama Ridge 8-5 Federal Com 153H Plan: Coterra West Grama Ridge 8-5 Federal Com 153H Rev0 kFc 16Aug24
			TVD Ref: RKB (3548.500 ft above MSL) Copy number: of 3 Date: 16-Aug-2024

Critical Point	MD	INCL	AZIM	TVD	VSEC	N(+)/S(-)	E(+)/W(-)	DLS
SHL [397' FSL, 560' FWL]	0.00	0.00	0.00	0.00	0.00	0.00	0.00	
Rustler	1655.00	0.00	144.39	1655.00	0.00	0.00	0.00	0.00
A3 Top	1720.00	0.00	144.39	1720.00	0.00	0.00	0.00	0.00
Nudge, Build 2"/100ft	1800.00	0.00	144.39	1800.00	0.00	0.00	0.00	0.00
A3 Base	1840.00	0.80	144.39	1840.00	-0.23	-0.23	0.16	2.00
Hold	2100.03	6.00	144.39	2099.48	-12.81	-12.76	9.14	2.00
Salado	2110.61	6.00	144.39	2110.00	-13.72	-13.66	9.78	0.00
Lamar	5177.41	6.00	144.39	5160.00	-275.42	-274.30	196.47	0.00
Bell Canyon	5227.69	6.00	144.39	5210.00	-279.71	-278.57	199.54	0.00
Drop 2"/100ft	5271.51	6.00	144.39	5253.59	-283.45	-282.29	202.20	0.00
Hold	5571.54	0.00	144.39	5553.07	-296.27	-295.05	211.34	2.00
Cherry Canyon	5878.47	0.00	144.39	5860.00	-296.27	-295.05	211.34	0.00
Brushy Canyon	7108.47	0.00	144.39	7090.00	-296.27	-295.05	211.34	0.00
Basal Brushy Canyon	8418.47	0.00	144.39	8400.00	-296.27	-295.05	211.34	0.00
Bone Springs Lime	8648.47	0.00	144.39	8630.00	-296.27	-295.05	211.34	0.00
Leonard	8813.47	0.00	144.39	8795.00	-296.27	-295.05	211.34	0.00
Avalon	8968.47	0.00	144.39	8950.00	-296.27	-295.05	211.34	0.00
KOP, Build 10"/100ft	9326.54	0.00	144.39	9308.07	-296.27	-295.05	211.34	0.00
1st BS SS	9786.23	45.97	359.67	9720.00	-121.55	-120.34	210.34	10.00
Build 5"/100ft	10076.54	75.00	359.67	9861.50	128.40	129.60	208.90	10.00
Landing Point	10341.08	88.23	359.67	9900.00	389.53	390.73	207.40	5.00
Section 8-5 Line Cross	14841.00	88.23	359.67	10039.23	4887.29	4888.42	181.54	0.00
West Grama Ridge 8-5 Federal Com 153H - BHL [100'FNL, 770'FWL]	20037.42	88.23	359.67	10200.00	10081.22	10082.26	151.67	0.00

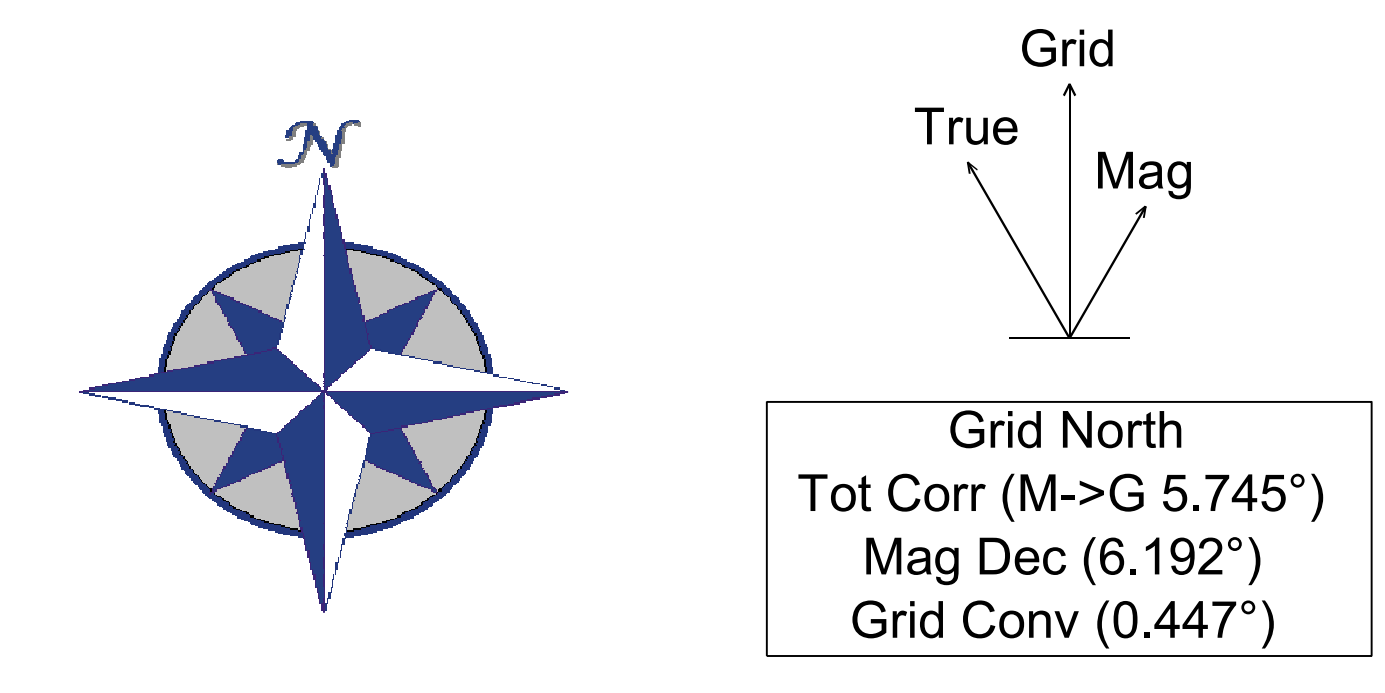

CONTROLLED	
Plan ref	Coterra West Grama Ridge 8-5 Federal Com 153H Rev0 kFc 16Aug24
Drawing ref	
Copy number	of 3
Date	16-Aug-2024
1 Client	
2 Client	
3 Office	
4 Office	
Copy number	for

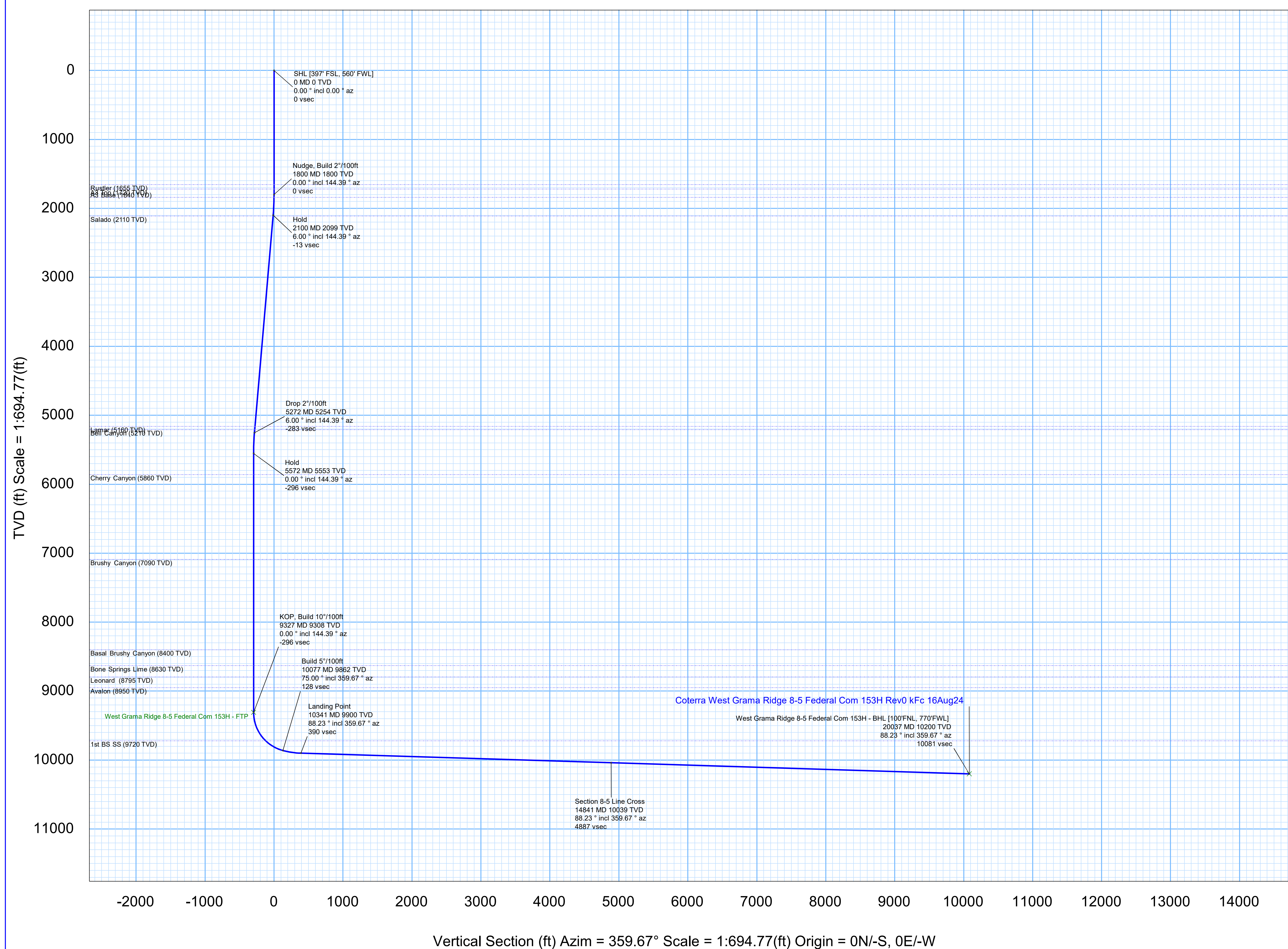

NS (ft) Scale = 1:518.17 (ft)

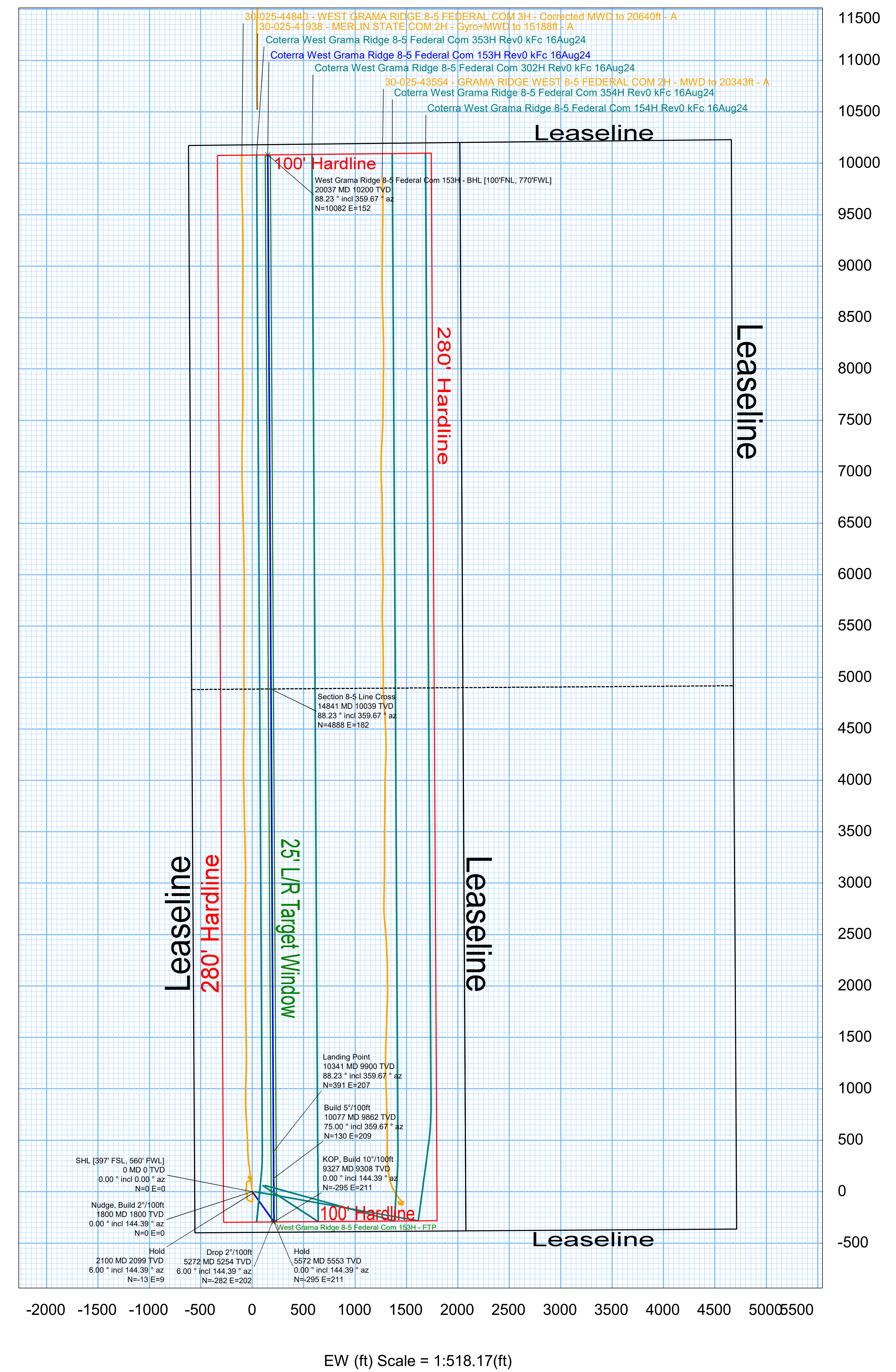

EW (ft) Scale = 1:518.17 (ft)



Coterra West Grama Ridge 8-5 Federal Com 153H Rev0 kFc 16Aug24
Proposal Geodetic Report
 Def Plan

Report Date:	August 16, 2024 - 06:19 PM (UTC 0)	Survey / DLS Computation:	Minimum Curvature / Lubinski
Client:	COTERRA	Vertical Section Azimuth:	359.670 *(GRID North)
Field:	NM Lea County (NAD 83)	Vertical Section Origin:	0.000 ft, 0.000 ft
Structure / Slot:	Coterra - West Grama Ridge 8-5 Federal Com Pads / West Grama	TVD Reference Datum:	RKB
Well:	West Grama Ridge 8-5 Federal Com 153H	TVD Reference Elevation:	3548.500 ft above MSL
Borehole:	West Grama Ridge 8-5 Federal Com 153H	Seabed / Ground Elevation:	3525.500 ft above MSL
UBHI / API#:	Unknown / Unknown	Magnetic Declination:	6.192°
Survey Name:	Coterra West Grama Ridge 8-5 Federal Com 153H Rev0 kFc 16Aug24	Total Gravity Field Strength:	998.4756mgn (9.80665 Based)
Survey Date:	August 16, 2024	Gravity Model:	GARM
Tort / AHD / DDI / ERD Ratio:	100.228° / 10740.425 ft / 6.325 / 1.053	Total Magnetic Field Strength:	47446.377 nT
Coordinate Reference System:	NAD83 New Mexico State Plane, Eastern Zone, US Feet	Magnetic Dip Angle:	59.98°
Location Lat / Long:	32°24'0.22100"N , 103°29'55.59341"W	Declination Date:	August 16, 2024
Location Grid N/E Y/X:	N 510278.900 ftUS , E 798914.640 ftUS	Magnetic Declination Model:	HDGM 2024
CRS Grid Convergence Angle:	0.447°	North Reference:	Grid North
Grid Scale Factor:	0.99998507(Applied)	Grid Convergence Used:	0.447°
Version / Patch:	2024.4.0.4	Total Corr Mag North->Grid North:	5.745°
		Local Coord Referenced To:	Well Head

Comments	MD (ft)	Incl (°)	Azim (°)	TVD (ft)	TVDSS (ft)	VSEC (ft)	NS (ft)	EW (ft)	Northing (ftUS)	Easting (ftUS)	Latitude (°)	Longitude (°)	DLS (°/100ft)	BR (°/100ft)	TR (°/100ft)
SHL [397' FSL, 560' FWL]	0.00	0.00	0.00	0.00	-3,548.50	0.00	0.00	0.00	510,278.90	798,914.64	32.40006139	-103.49877595			
	100.00	0.00	144.39	100.00	-3,448.50	0.00	0.00	0.00	510,278.90	798,914.64	32.40006139	-103.49877595	0.00	0.00	0.00
	200.00	0.00	144.39	200.00	-3,348.50	0.00	0.00	0.00	510,278.90	798,914.64	32.40006139	-103.49877595	0.00	0.00	0.00
	300.00	0.00	144.39	300.00	-3,248.50	0.00	0.00	0.00	510,278.90	798,914.64	32.40006139	-103.49877595	0.00	0.00	0.00
	400.00	0.00	144.39	400.00	-3,148.50	0.00	0.00	0.00	510,278.90	798,914.64	32.40006139	-103.49877595	0.00	0.00	0.00
	500.00	0.00	144.39	500.00	-3,048.50	0.00	0.00	0.00	510,278.90	798,914.64	32.40006139	-103.49877595	0.00	0.00	0.00
	600.00	0.00	144.39	600.00	-2,948.50	0.00	0.00	0.00	510,278.90	798,914.64	32.40006139	-103.49877595	0.00	0.00	0.00
	700.00	0.00	144.39	700.00	-2,848.50	0.00	0.00	0.00	510,278.90	798,914.64	32.40006139	-103.49877595	0.00	0.00	0.00
	800.00	0.00	144.39	800.00	-2,748.50	0.00	0.00	0.00	510,278.90	798,914.64	32.40006139	-103.49877595	0.00	0.00	0.00
	900.00	0.00	144.39	900.00	-2,648.50	0.00	0.00	0.00	510,278.90	798,914.64	32.40006139	-103.49877595	0.00	0.00	0.00
	1,000.00	0.00	144.39	1,000.00	-2,548.50	0.00	0.00	0.00	510,278.90	798,914.64	32.40006139	-103.49877595	0.00	0.00	0.00
	1,100.00	0.00	144.39	1,100.00	-2,448.50	0.00	0.00	0.00	510,278.90	798,914.64	32.40006139	-103.49877595	0.00	0.00	0.00
	1,200.00	0.00	144.39	1,200.00	-2,348.50	0.00	0.00	0.00	510,278.90	798,914.64	32.40006139	-103.49877595	0.00	0.00	0.00
	1,300.00	0.00	144.39	1,300.00	-2,248.50	0.00	0.00	0.00	510,278.90	798,914.64	32.40006139	-103.49877595	0.00	0.00	0.00
	1,400.00	0.00	144.39	1,400.00	-2,148.50	0.00	0.00	0.00	510,278.90	798,914.64	32.40006139	-103.49877595	0.00	0.00	0.00
	1,500.00	0.00	144.39	1,500.00	-2,048.50	0.00	0.00	0.00	510,278.90	798,914.64	32.40006139	-103.49877595	0.00	0.00	0.00
	1,600.00	0.00	144.39	1,600.00	-1,948.50	0.00	0.00	0.00	510,278.90	798,914.64	32.40006139	-103.49877595	0.00	0.00	0.00
Rustler	1,655.00	0.00	144.39	1,655.00	-1,893.50	0.00	0.00	0.00	510,278.90	798,914.64	32.40006139	-103.49877595	0.00	0.00	0.00
	1,700.00	0.00	144.39	1,700.00	-1,848.50	0.00	0.00	0.00	510,278.90	798,914.64	32.40006139	-103.49877595	0.00	0.00	0.00
A3 Top	1,720.00	0.00	144.39	1,720.00	-1,828.50	0.00	0.00	0.00	510,278.90	798,914.64	32.40006139	-103.49877595	0.00	0.00	0.00
Nudge, Build 2°/100ft	1,800.00	0.00	144.39	1,800.00	-1,748.50	0.00	0.00	0.00	510,278.90	798,914.64	32.40006139	-103.49877595	0.00	0.00	0.00
A3 Base	1,840.00	0.80	144.39	1,840.00	-1,708.50	-0.23	-0.23	0.16	510,278.67	798,914.80	32.40006076	-103.49877543	2.00	2.00	0.00
	1,900.00	2.00	144.39	1,899.98	-1,648.52	-1.42	-1.42	1.02	510,277.48	798,915.66	32.40005747	-103.49877269	2.00	2.00	0.00
	2,000.00	4.00	144.39	1,999.84	-1,548.66	-5.70	-5.67	4.06	510,273.23	798,918.70	32.40004571	-103.49876293	2.00	2.00	0.00
	2,100.00	6.00	144.39	2,099.45	-1,449.05	-12.81	-12.76	9.14	510,266.14	798,923.78	32.40002613	-103.49874666	2.00	2.00	0.00
Hold	2,100.03	6.00	144.39	2,099.48	-1,449.02	-12.81	-12.76	9.14	510,266.14	798,923.78	32.40002612	-103.49874666	2.00	2.00	0.00
Salado	2,110.61	6.00	144.39	2,110.00	-1,438.50	-13.72	-13.66	9.78	510,265.24	798,924.42	32.40002364	-103.49874459	0.00	0.00	0.00
	2,200.00	6.00	144.39	2,198.90	-1,349.60	-21.34	-21.26	15.23	510,257.64	798,929.87	32.40002064	-103.49872716	0.00	0.00	0.00
	2,300.00	6.00	144.39	2,298.36	-1,250.14	-29.88	-29.76	21.31	510,249.14	798,935.95	32.39997915	-103.49870765	0.00	0.00	0.00
	2,400.00	6.00	144.39	2,397.81	-1,150.69	-38.41	-38.25	27.40	510,240.65	798,942.04	32.39995566	-103.49868814	0.00	0.00	0.00
	2,500.00	6.00	144.39	2,497.26	-1,051.24	-46.95	-46.75	33.49	510,232.15	798,948.13	32.39993217	-103.49866864	0.00	0.00	0.00
	2,600.00	6.00	144.39	2,596.71	-951.79	-55.48	-55.25	39.58	510,223.65	798,954.22	32.39990868	-103.49864913	0.00	0.00	0.00
	2,700.00	6.00	144.39	2,696.16	-852.34	-64.01	-63.75	45.66	510,215.15	798,960.30	32.39988519	-103.49862962	0.00	0.00	0.00
	2,800.00	6.00	144.39	2,795.62	-752.88	-72.55	-72.25	51.75	510,206.65	798,966.39	32.39986170	-103.49861012	0.00	0.00	0.00
	2,900.00	6.00	144.39	2,895.07	-653.43	-81.08	-80.75	57.84	510,198.15	798,972.48	32.39983821	-103.49859061	0.00	0.00	0.00
	3,000.00	6.00	144.39	2,994.52	-553.98	-89.61	-89.25	63.93	510,189.66	798,978.56	32.39981472	-103.49857111	0.00	0.00	0.00
	3,100.00	6.00	144.39	3,093.97	-454.53	-98.15	-97.74	70.01	510,181.16	798,984.65	32.39979124	-103.49855160	0.00	0.00	0.00
	3,200.00	6.00	144.39	3,193.42	-355.08	-106.68	-106.24	76.10	510,172.66	798,990.74	32.39976775	-103.49853209	0.00	0.00	0.00
	3,300.00	6.00	144.39	3,292.88	-255.62	-115.21	-114.74	82.19	510,164.16	798,996.83	32.39974426	-103.49851259	0.00	0.00	0.00
	3,400.00	6.00	144.39	3,392.33	-156.17	-123.75	-123.24	88.28	510,155.66	799,002.91	32.39972077	-103.49849308	0.00	0.00	0.00
	3,500.00	6.00	144.39	3,491.78	-66.72	-132.28	-131.74	94.36	510,147.16	799,009.00	32.39969728	-103.49847357	0.00	0.00	0.00
	3,600.00	6.00	144.39	3,591.23	42.73	-140.81	-140.24	100.45	510,138.66	799,015.09	32.39967379	-103.49845407	0.00	0.00	0.00
	3,700.00	6.00	144.39	3,690.69	142.19	-149.35	-148.74	106.54	510,130.17	799,021.18	32.39965030	-103.49843456	0.00	0.00	0.00
	3,800.00	6.00	144.39	3,790.14	241.64	-157.88	-157.24	112.63	510,121.67	799,027.26	32.39962681	-103.49841505	0.00	0.00	0.00
	3,900.00	6.00	144.39	3,889.59	341.09	-166.41	-165.73	118.71	510,113.17	799,033.35	32.39960332	-103.49839555	0.00	0.00	0.00
	4,000.00	6.00	144.39	3,989.04	440.54	-174.95	-174.23	124.80	510,104.67	799,039.44	32.39957983	-103.49837604	0.00	0.00	0.00
	4,100.00	6.00	144.39	4,088.49	539.99	-183.48	-182.73	130.89	510,096.17	799,045.53	32.39955634	-103.49835654	0.00	0.00	0.00
	4,200.00	6.00	144.39	4,187.95	639.45	-192.02	-191.23	136.98	510,087.67	799,051.61	32.39953286	-103.49833703	0.00	0.00	0.00
	4,300.00	6.00	144.39	4,287.40	738.90	-200.55	-199.73	143.06	510,079.17	799,057.70	32.39950937	-103.49831752	0.00	0.00	0.00
	4,400.00	6.00	144.39	4,386.85	838.35	-209.08	-208.23	149.15	510,070.68	799,063.79	32.39948588	-103.49829802	0.00	0.00	0.00
	4,500.00	6.00	144.39	4,486.30	937.80	-217.62	-216.73	155.24	510,062.18	799,069.87	32.39946239	-103.49827851	0.00	0.00	0.00
	4,600.00	6.00	144.39	4,585.75	1,037.25	-226.15	-225.22	161.33	510,053.68	799,075.96	32.39943890	-103.49825900	0.00	0.00	0.00
	4,700.00	6.00	144.39	4,685.21	1,136.71	-234.68	-233.72	167.41	510,045.18	799,082.05	32.39941541	-103.49823950	0.00	0.00	0.00
	4,800.00	6.00	144.39	4,784.66	1,236.16	-243.22	-242.22	173.50	510,036.68	799,088.14	32.39939192	-103.49822000	0.00	0.00	0.00
	4,900.00	6.00	144.39	4,884.11	1,335.61	-251.75	-250.72	179.59	510,028.18	799,094.22	32.39936843	-103.49820049	0.00	0.00	0.00
	5,000.00	6.00	144.39	4,983.56	1,435.06	-260.28	-259.22	185.67	510,019.69	799,100.31	32.39934494	-103.49818098	0.00	0.00	0.00
	5,100.00	6.00	144.39	5,083.01	1,534.51	-268.82	-267.72	191.76	510,011.19	799,106.40	32.39932145	-103.49816147	0.00	0.00	0.00
Lamar	5,177.41	6.00	144.39	5,160.00	1,611.50	-275.42	-274.30	196.							

Comments	MD (ft)	Incl (°)	Azim (°)	TVD (ft)	TVDSS (ft)	VSEC (ft)	NS (ft)	EW (ft)	Northing (ftUS)	Easting (ftUS)	Latitude (°)	Longitude (°)	DLS (°/100ft)	BR (°/100ft)	TR (°/100ft)
KOP, Build 10"/100ft	9,326.54	0.00	144.39	9,308.07	5,759.57	-296.27	-295.05	211.34	509,983.85	799,125.98	32.39924590	-103.49809873	0.00	0.00	0.00
	9,400.00	7.35	359.67	9,381.33	5,832.83	-291.57	-290.35	211.32	509,988.55	799,125.95	32.39925882	-103.49809870	10.00	10.00	0.00
	9,500.00	17.35	359.67	9,478.89	5,930.39	-270.21	-269.00	211.19	510,009.91	799,125.83	32.39931751	-103.49809856	10.00	10.00	0.00
	9,600.00	27.35	359.67	9,571.26	6,022.76	-232.24	-231.03	210.97	510,047.87	799,125.61	32.39942188	-103.49809830	10.00	10.00	0.00
1st BS SS	9,700.00	37.35	359.67	9,655.64	6,107.14	-178.81	-177.60	210.67	510,101.31	799,125.30	32.39956875	-103.49809795	10.00	10.00	0.00
	9,786.23	45.97	359.67	9,720.00	6,171.50	-121.55	-120.34	210.34	510,158.56	799,124.97	32.39972612	-103.49809757	10.00	10.00	0.00
	9,800.00	47.35	359.67	9,729.45	6,180.95	-111.53	-110.32	210.28	510,168.58	799,124.92	32.39975366	-103.49809750	10.00	10.00	0.00
	9,900.00	57.35	359.67	9,790.47	6,241.97	-32.46	-31.25	209.82	510,247.65	799,124.46	32.39997099	-103.49809698	10.00	10.00	0.00
Build 5"/100ft	10,000.00	67.35	359.67	9,836.82	6,288.32	56.00	57.21	209.31	510,336.11	799,123.95	32.40021414	-103.49809639	10.00	10.00	0.00
	10,076.54	75.00	359.67	9,861.50	6,313.00	128.40	129.60	208.90	510,408.50	799,123.53	32.40041312	-103.49809591	10.00	10.00	0.00
	10,100.00	76.17	359.67	9,867.34	6,318.84	151.12	152.32	208.77	510,431.22	799,123.40	32.40047556	-103.49809575	5.00	5.00	0.00
	10,200.00	81.17	359.67	9,886.98	6,338.48	249.14	250.34	208.20	510,529.24	799,122.84	32.40074498	-103.49809510	5.00	5.00	0.00
Landing Point	10,300.00	86.17	359.67	9,898.00	6,349.50	348.50	349.70	207.63	510,628.59	799,122.27	32.40101807	-103.49809444	5.00	5.00	0.00
	10,341.08	88.23	359.67	9,900.00	6,351.50	389.53	390.73	207.40	510,669.62	799,122.03	32.40113086	-103.49809417	5.00	5.00	0.00
	10,400.00	88.23	359.67	9,901.83	6,353.33	448.42	449.62	207.06	510,728.51	799,121.69	32.40129271	-103.49809377	0.00	0.00	0.00
	10,500.00	88.23	359.67	9,904.92	6,356.42	548.37	549.57	206.48	510,828.46	799,121.12	32.40156744	-103.49809310	0.00	0.00	0.00
Section 8-5 Line Cross	10,600.00	88.23	359.67	9,908.01	6,359.51	648.32	649.52	205.91	510,928.41	799,120.54	32.40184216	-103.49809244	0.00	0.00	0.00
	10,700.00	88.23	359.67	9,911.11	6,362.61	748.27	749.47	205.33	511,028.36	799,119.97	32.40211689	-103.49809177	0.00	0.00	0.00
	10,800.00	88.23	359.67	9,914.20	6,365.70	848.23	849.42	204.76	511,128.30	799,119.39	32.40239161	-103.49809110	0.00	0.00	0.00
	10,900.00	88.23	359.67	9,917.29	6,368.79	948.18	949.37	204.18	511,228.25	799,118.82	32.40266634	-103.49809043	0.00	0.00	0.00
West Grama Ridge 8-5 Federal C	11,000.00	88.23	359.67	9,920.39	6,371.89	1,048.13	1,049.32	203.61	511,328.20	799,118.24	32.40294106	-103.49808976	0.00	0.00	0.00
	11,100.00	88.23	359.67	9,923.48	6,374.98	1,148.08	1,149.27	203.03	511,428.15	799,117.67	32.40321579	-103.49808910	0.00	0.00	0.00
	11,200.00	88.23	359.67	9,926.58	6,378.08	1,248.03	1,249.22	202.46	511,528.10	799,117.10	32.40349051	-103.49808843	0.00	0.00	0.00
	11,300.00	88.23	359.67	9,929.67	6,381.17	1,347.99	1,349.17	201.88	511,628.05	799,116.52	32.40376524	-103.49808776	0.00	0.00	0.00

Survey Type: Def Plan

Survey Error Model: ISCWSA0 3 - D 95 % Confidence 2.7955 sigma

Survey Program:

Description	Part	MD From (ft)	MD To (ft)	EOU Freq (ft)	Hole Size (in)	Casing Diameter (in)	Expected Max Inclination (deg)	Survey Tool Code	Vendor / Tool	Borehole / Survey
	1	0.000	9,300.000	1/100.000	14.75 – 9.875	10.75 – 7.625		A001Mb_MWD		West Grama Ridge 8-5 Federal Com 153H / Coter
	1	9,300.000	20,037.417	1/100.000	9.875 – 6.75	7.625 – 5		A008Mb_MWD+IFR1+MS		West Grama Ridge 8-5 Federal Com 153H / Coter

EOU Geometry:

End MD (ft)	Hole Size (in)	Casing Size (in)	Name
-------------	----------------	------------------	------

Comments	MD (ft)	Incl (°)	Azim (°)	TVD (ft)	TVDS (ft)	VSEC (ft)	NS (ft)	EW (ft)	Northing (ftUS)	Easting (ftUS)	Latitude (°)	Longitude (°)	DLS (°/100ft)	BR (°/100ft)	TR (°/100ft)
1,125.100		14.750		10.750											
11,625.100		9.875		7.625											
20,037.417		6.750		5.000											

**PECOS DISTRICT
SURFACE USE
CONDITIONS OF APPROVAL**

OPERATOR'S NAME:	Cimarex Energy Company
LEASE NO.:	NMNM129267
COUNTY:	Lea County, New Mexico

Wells:

West Grama Ridge 8-5 Federal Com 153H

West Grama Ridge 8-5 Federal Com 154H

West Grama Ridge 8-5 Federal Com 353H

West Grama Ridge 8-5 Federal Com 354H

TABLE OF CONTENTS

1. GENERAL PROVISIONS	3
1. SPECIAL REQUIREMENTS	3
2.3 WILDLIFE	3
2.3.1 Lesser Prairie Chicken	3

1. GENERAL PROVISIONS

The failure of the operator to comply with these requirements may result in the assessment of liquidated damages or penalties pursuant to 43 CFR 3163.1 or 3163.2. A copy of these conditions of approval shall be present on the location during construction, drilling and reclamation activity. Any request for a variance shall be submitted to the Authorized Officer on Form 3160-5, Sundry Notices and Report on Wells.

1. SPECIAL REQUIREMENTS

2.3 WILDLIFE

2.3.1 Lesser Prairie Chicken

2.3.1.1 Timing Limitation Stipulation/Condition of Approval for Lesser Prairie-Chicken:

Oil and gas activities including 3-D geophysical exploration, and drilling will not be allowed in lesser prairie-chicken habitat during the period from March 1st through June 15th annually. During that period, other activities that produce noise or involve human activity, such as the maintenance of oil and gas facilities, geophysical exploration other than 3-D operations, and pipeline, road, and well pad construction, will be allowed except between 3:00 am and 9:00 am. The 3:00 am to 9:00 am restriction will not apply to normal, around-the-clock operations, such as venting, flaring, or pumping, which do not require a human presence during this period. Additionally, no new drilling will be allowed within up to 200 meters of leks known at the time of permitting. Normal vehicle use on existing roads will not be restricted. Exhaust noise from pump jack engines must be muffled or otherwise controlled so as not to exceed 75 db measured at 30 ft. from the source of the noise.

2.3.1.2 Timing Limitation Exceptions:

The Carlsbad Field Office will publish an annual map of where the LPC timing and noise stipulations and conditions of approval (Limitations) will apply for the identified year (between March 1 and June 15) based on the latest survey information. The LPC Timing Area map will identify areas which are Habitat Areas (HA), Isolated Population Area (IPA), and Primary Population Area (PPA). The LPC Timing Area map will also have an area in red crosshatch. The red crosshatch area is the only area where an operator is required to submit a request for exception to the LPC Limitations. If an operator is operating outside the red crosshatch area, the LPC Limitations do not apply for that year and an exception to LPC Limitations is not required.

2.3.1.3 Ground-level Abandoned Well Marker to avoid raptor perching:

Upon the plugging and subsequent abandonment of the well, the well marker will be installed at ground level on a plate containing the pertinent information for the plugged well. For more installation details, contact the Carlsbad Field Office at BLM_NM_CFO_Construction_Reclamation@blm.gov.

PECOS DISTRICT DRILLING CONDITIONS OF APPROVAL

OPERATOR'S NAME:	Cimarex Energy Company
LOCATION:	Section 8, T.22 S., R.34 E., NMPM
COUNTY:	Lea County, New Mexico

WELL NAME & NO.:	West Grama Ridge 8-5 Federal Com 153H
ATS/API ID:	ATS-24-2687
APD ID:	10400100659
Sundry ID:	N/a

WELL NAME & NO.:	West Grama Ridge 8-5 Federal Com 154H
ATS/API ID:	ATS-24-2686
APD ID:	10400100666
Sundry ID:	N/a

COA

H2S	No		
Potash	None	None	
Cave/Karst Potential	Low		
Cave/Karst Potential	<input type="checkbox"/> Critical		
Variance	<input checked="" type="checkbox"/> None	<input checked="" type="checkbox"/> Flex Hose	<input checked="" type="checkbox"/> Other
Wellhead	Conventional and Multibowl		
Other	<input type="checkbox"/> 4 String <input type="checkbox"/> 5 String	Capitan Reef None	<input type="checkbox"/> WIPP
Other	Pilot Hole None	<input type="checkbox"/> Open Annulus	
Cementing	Contingency Squeeze None	Echo-Meter None	Primary Cement Squeeze None
Special Requirements	<input type="checkbox"/> Water Disposal/Injection	<input checked="" type="checkbox"/> COM	<input type="checkbox"/> Unit
Special Requirements	<input type="checkbox"/> Batch Sundry	Waste Prevention Waste MP	
Special Requirements Variance	<input type="checkbox"/> Break Testing	<input type="checkbox"/> Offline Cementing	<input type="checkbox"/> Casing Clearance

A. HYDROGEN SULFIDE

Hydrogen Sulfide (H₂S) monitors shall be installed prior to drilling out the surface shoe. If H₂S is detected in concentrations greater than 100 ppm, the Hydrogen Sulfide area shall meet **43 CFR part 3170 Subpart 3176**, which includes equipment and personnel/public protection items. If Hydrogen Sulfide is encountered, provide measured values and formations to the BLM.

B. CASING

1. The **13-3/8** inch surface casing shall be set at approximately **1720 feet** (a minimum of **25 feet (Lea County)**) into the Rustler Anhydrite and above the salt when present, and below usable fresh water) and cemented to the surface. The surface hole shall be **17 1/2** inch in diameter.
 - a. If cement does not circulate to the surface, the appropriate BLM office shall be notified and a temperature survey utilizing an electronic type temperature survey with surface log readout will be used or a cement bond log shall be run to verify the top of the cement. Temperature survey will be run a minimum of six hours after pumping cement and ideally between 8-10 hours after completing the cement job.
 - b. Wait on cement (WOC) time for a primary cement job will be a minimum of **8 hours** or 500 pounds compressive strength, whichever is greater. (This is to include the lead cement)
 - c. Wait on cement (WOC) time for a remedial job will be a minimum of 4 hours after bringing cement to surface or 500 pounds compressive strength, whichever is greater.
 - d. If cement falls back, remedial cementing will be done prior to drilling out that string.
2. The minimum required fill of cement behind the **9-5/8** inch intermediate casing is:
 - Cement to surface. If cement does not circulate see B.1.a, c-d above.
3. The minimum required fill of cement behind the **7** inch production casing is:
 - Cement should tie-back at least **200 feet** into previous casing string. Operator shall provide method of verification.
4. The minimum required fill of cement behind the **4-1/2** inch production liner is:
 - Cement should tie-back **100 feet** into the previous casing. Operator shall provide method of verification.
Cement excess is less than 25%, more cement is required if washout occurs. Adjust cement volume and excess based on a fluid caliper or similar method that reflects the as-drilled size of the wellbore.

C. PRESSURE CONTROL

1. Variance approved to use flex line from BOP to choke manifold. Manufacturer's specification to be readily available. No external damage to flex line. Flex line to be installed as straight as possible (no hard bends).'
- 2.

Option 1:

- a. Minimum working pressure of the blowout preventer (BOP) and related equipment (BOPE) required for drilling below the surface casing shoe shall be **3000 (3M)** psi.
- b. Minimum working pressure of the blowout preventer (BOP) and related equipment (BOPE) required for drilling below the **9-5/8** intermediate casing shoe shall be **5000 (5M)** psi.

Option 2:

- a. Operator has proposed a multi-bowl wellhead assembly. This assembly will only be tested when installed on the **13-3/8** inch surface casing. Minimum working pressure of the blowout preventer (BOP) and related equipment (BOPE) required for drilling below the surface casing shoe shall be **5000 (5M)** psi.
 - a. Wellhead shall be installed by manufacturer's representatives, submit documentation with subsequent sundry.
 - b. If the welding is performed by a third party, the manufacturer's representative shall monitor the temperature to verify that it does not exceed the maximum temperature of the seal.
 - c. Manufacturer representative shall install the test plug for the initial BOP test.
 - d. If the cement does not circulate and one inch operations would have been possible with a standard wellhead, the well head shall be cut off, cementing operations performed and another wellhead installed.
 - e. Whenever any seal subject to test pressure is broken, all the tests in 43 CFR 3172.6(b)(9) must be followed.

D. SPECIAL REQUIREMENT (S)

Communitization Agreement

- The operator will submit a Communitization Agreement to the Santa Fe Office, 301 Dinosaur Trail Santa Fe, New Mexico 87508, at least 90 days before the anticipated date of first production from a well subject to a spacing order issued by the New

Mexico Oil Conservation Division. The Communitization Agreement will include the signatures of all working interest owners in all Federal and Indian leases subject to the Communitization Agreement (i.e., operating rights owners and lessees of record), or certification that the operator has obtained the written signatures of all such owners and will make those signatures available to the BLM immediately upon request.

- The operator will submit an as-drilled survey well plat of the well completion, but are not limited to, those specified in **43 CFR part 3170 Subpart 3171**
- If the operator does not comply with this condition of approval, the BLM may take enforcement actions that include, but are not limited to, those specified in 43 CFR 3163.1.
- In addition, the well sign shall include the surface and bottom hole lease numbers. When the Communitization Agreement number is known, it shall also be on the sign.

GENERAL REQUIREMENTS

The BLM is to be notified in advance for a representative to witness:

- a. Spudding well (minimum of 24 hours)
- b. Setting and/or Cementing of all casing strings (minimum of 4 hours)
- c. BOPE tests (minimum of 4 hours)

Lea County

Call the Hobbs Field Station, 414 West Taylor, Hobbs NM 88240,
(575) 689-5981

1. Unless the production casing has been run and cemented or the well has been properly plugged, the drilling rig shall not be removed from over the hole without prior approval.
 - a. In the event the operator has proposed to drill multiple wells utilizing a skid/walking rig. Operator shall secure the wellbore on the current well, after installing and testing the wellhead, by installing a blind flange of like pressure rating to the wellhead and a pressure gauge that can be monitored while drilling is performed on the other well(s).
 - b. When the operator proposes to set surface casing with Spudder Rig
 - Notify the BLM when moving in and removing the Spudder Rig.
 - Notify the BLM when moving in the 2nd Rig. Rig to be moved in within 90 days of notification that Spudder Rig has left the location.
 - BOP/BOPE test to be conducted per **43 CFR part 3170 Subpart 3172** as soon as 2nd Rig is rigged up on well.
2. Floor controls are required for 3M or Greater systems. These controls will be on the rig floor, unobstructed, readily accessible to the driller and will be operational at all times during drilling and/or completion activities. Rig floor is defined as the area immediately around the rotary table; the area immediately above the substructure on which the draw works are located, this does not include the dog house or stairway area.

A. CASING

1. Changes to the approved APD casing program need prior approval if the items substituted are of lesser grade or different casing size or are Non-API. The Operator can exchange the components of the proposal with that of superior strength (i.e. changing from J-55 to N-80, or from 36# to 40#). Changes to the approved cement program need prior approval if the altered cement plan has less volume or strength or if the changes are substantial (i.e. Multistage tool, ECP, etc.). The initial wellhead installed on the well will remain on the well with spools used as needed.

2. Wait on cement (WOC) for Potash Areas: After cementing but before commencing any tests, the casing string shall stand cemented under pressure until both of the following conditions have been met: 1) cement reaches a minimum compressive strength of 500 psi for all cement blends of both lead and tail cement, 2) until cement has been in place at least 8 hours. WOC time will be recorded in the driller's log. The casing integrity test can be done (prior to the cement setting up) immediately after bumping the plug.
3. Wait on cement (WOC) for Water Basin: After cementing but before commencing any tests, the casing string shall stand cemented under pressure until both of the following conditions have been met: 1) cement reaches a minimum compressive strength of 500 psi at the shoe, 2) until cement has been in place at least 8 hours. WOC time will be recorded in the driller's log. See individual casing strings for details regarding lead cement slurry requirements. The casing integrity test can be done (prior to the cement setting up) immediately after bumping the plug.
4. Provide compressive strengths including hours to reach required 500 pounds compressive strength prior to cementing each casing string. Have well specific cement details onsite prior to pumping the cement for each casing string.
5. No pea gravel permitted for remedial or fall back remedial without prior authorization from the BLM engineer.
6. On that portion of any well approved for a 5M BOPE system or greater, a pressure integrity test of each casing shoe shall be performed. Formation at the shoe shall be tested to a minimum of the mud weight equivalent anticipated to control the formation pressure to the next casing depth or at total depth of the well. This test shall be performed before drilling more than 20 feet of new hole.
7. If hardband drill pipe is rotated inside casing, returns will be monitored for metal. If metal is found in samples, drill pipe will be pulled and rubber protectors which have a larger diameter than the tool joints of the drill pipe will be installed prior to continuing drilling operations.
8. Whenever a casing string is cemented in the R-111-P potash area, the NMOCD requirements shall be followed.

B. PRESSURE CONTROL

1. All blowout preventer (BOP) and related equipment (BOPE) shall comply with well control requirements as described in **43 CFR part 3170 Subpart 3172 and API STD 53 Sec. 5.3**.
2. If a variance is approved for a flexible hose to be installed from the BOP to the choke manifold, the following requirements apply: The flex line must meet the requirements of API 16C. Check condition of flexible line from BOP to choke

manifold, replace if exterior is damaged or if line fails test. Line to be as straight as possible with no hard bends and is to be anchored according to Manufacturer's requirements. The flexible hose can be exchanged with a hose of equal size and equal or greater pressure rating. Anchor requirements, specification sheet and hydrostatic pressure test certification matching the hose in service, to be onsite for review. These documents shall be posted in the company man's trailer and on the rig floor.

3. 5M or higher system requires an HCR valve, remote kill line and annular to match. The remote kill line is to be installed prior to testing the system and tested to stack pressure.
4. If the operator has proposed a multi-bowl wellhead assembly in the APD. The following requirements must be met:
 - a. Wellhead shall be installed by manufacturer's representatives, submit documentation with subsequent sundry.
 - b. If the welding is performed by a third party, the manufacturer's representative shall monitor the temperature to verify that it does not exceed the maximum temperature of the seal.
 - c. Manufacturer representative shall install the test plug for the initial BOP test.
 - d. Whenever any seal subject to test pressure is broken, all the tests in 43 CFR 3172.6(b)(9) must be followed.
 - e. If the cement does not circulate and one inch operations would have been possible with a standard wellhead, the well head shall be cut off, cementing operations performed and another wellhead installed.
5. The appropriate BLM office shall be notified a minimum of 4 hours in advance for a representative to witness the tests.
 - a. In a water basin, for all casing strings utilizing slips, these are to be set as soon as the crew and rig are ready and any fallback cement remediation has been done. The casing cut-off and BOP installation can be initiated four hours after installing the slips, which will be approximately six hours after bumping the plug. For those casing strings not using slips, the minimum wait time before cut-off is eight hours after bumping the plug. BOP/BOPE testing can begin after cut-off or once cement reaches 500 psi compressive strength (including lead cement), whichever is greater. However, if the float does not hold, cut-off cannot be initiated until cement reaches 500 psi compressive strength (including lead when specified).
 - b. In potash areas, for all casing strings utilizing slips, these are to be set as soon as the crew and rig are ready and any fallback cement remediation has been done. For all casing strings, casing cut-off and BOP installation can be initiated at twelve hours after bumping the cement plug. The BOPE test can be

initiated after bumping the cement plug with the casing valve open. (only applies to single stage cement jobs, prior to the cement setting up.)

- c. The tests shall be done by an independent service company utilizing a test plug not a cup or J-packer and can be initiated immediately with the casing valve open. The operator also has the option of utilizing an independent tester to test without a plug (i.e. against the casing) pursuant to **43 CFR part 3170 Subpart 3172** with the pressure not to exceed 70% of the burst rating for the casing. Any test against the casing must meet the WOC time for 8 hours or 500 pounds compressive strength, whichever is greater, prior to initiating the test (see casing segment as lead cement may be critical item).
- d. The test shall be run on a 5000 psi chart for a 2-3M BOP/BOP, on a 10000 psi chart for a 5M BOP/BOPE and on a 15000 psi chart for a 10M BOP/BOPE. If a linear chart is used, it shall be a one hour chart. A circular chart shall have a maximum 2 hour clock. If a twelve hour or twenty-four hour chart is used, tester shall make a notation that it is run with a two hour clock.
- e. The results of the test shall be reported to the appropriate BLM office.
- f. All tests are required to be recorded on a calibrated test chart. A copy of the BOP/BOPE test chart and a copy of independent service company test will be submitted to the appropriate BLM office.
- g. The BOP/BOPE test shall include a low pressure test from 250 to 300 psi. The test will be held for a minimum of 10 minutes if test is done with a test plug and 30 minutes without a test plug. This test shall be performed prior to the test at full stack pressure.
- h. BOP/BOPE must be tested by an independent service company within 500 feet of the top of the Wolfcamp formation if the time between the setting of the intermediate casing and reaching this depth exceeds 20 days. This test does not exclude the test prior to drilling out the casing shoe as per **43 CFR part 3170 Subpart 3172**.

C. DRILLING MUD

Mud system monitoring equipment, with derrick floor indicators and visual and audio alarms, shall be operating before drilling into the Wolfcamp formation, and shall be used until production casing is run and cemented.

D. WASTE MATERIAL AND FLUIDS

All waste (i.e. drilling fluids, trash, salts, chemicals, sewage, gray water, etc.) created as a result of drilling operations and completion operations shall be safely contained and

disposed of properly at a waste disposal facility. No waste material or fluid shall be disposed of on the well location or surrounding area.

Porto-johns and trash containers will be on-location during fracturing operations or any other crew-intensive operations.

Long Vo (LVO) 1/22/2025

Coterra: H2S Plan



H2S Drilling Operations Plan

Training

All company and contract personnel admitted on location must be trained by a qualified H2S safety instructor to do the following:

1. Characteristics of H2S
2. Physical effects and hazards
3. Principle and operation of H2S detectors, warning system, and briefing areas
4. Evacuation procedure, routes and first aid
5. Proper use of safety equipment & life support systems
6. Essential personnel meeting Medical Evaluation criteria will receive additional training on the proper use of 30 minute pressure demand air packs.

H2S Detection and Alarm Systems

1. H2S sensors/detectors to be located on the drilling rig floor, in the base of the sub structure/cellar area, on the mud pits in the shale shaker area. Additional H2S detectors may be placed as deemed necessary
2. An audio alarm system will be installed on the derrick floor and in the top doghouse

Windsock and/or wind streamers

1. Windsock at mudpit area should be high enough to be visible
2. Windsock on the rig floor and / or top of doghouse should be high enough to be visible

Condition Flags & Signs

1. Warning signs on access road to location
2. Flags are to be displayed on sign at the entrance to location. Green flag indicates normal safe condition. Yellow flag indicates potential pressure and danger. Red flag indicates

Coterra: H2S Plan

danger (H2S present in dangerous concentration). Only H2S trained and certified personnel admitted to location.

Well Control Equipment

1. See the pressure control section of this submission.

Communication

1. While working under masks, chalkboards will be used for communication
2. Hand signals will be used where chalk board is inappropriate.
3. Two way radio will be used to communicate off location in case emergency help is required. In most cases, cellular telephones will be available at most drilling foreman's trailer or living quarters.

Drillstem Testing

1. No DSTs or cores are planned at this time
2. Drilling contractor supervisor will be required to be familiar with the effects that H2S has on tubular goods and other mechanical equipment.
3. If H2S is encountered, mud system will be altered if necessary to maintain control of the well. A mud gas separator will be brought into service along with H2S scavenger if necessary.

Coterra: H2S Plan

H2S Contingency Plan

Emergency Procedures

In the event of an H2S release, the first responder(s) must:

1. Isolate the area and prevent entry by other persons into the 100 PPM ROE.
2. Evacuate any public places encompassed by the 100 PPM ROE.
3. Be equipped with H2S monitors and air packs in order to control the release.
4. Use the buddy system
5. Take precautions to avoid personal injury during this operation
6. Contact operator and/or local officials to aid in operation. See list of emergency contacts attached.
7. Have received training the detection of H2S, measures for protection against the gas, and equipment used for protection and emergency response

Ignition of the Gas Source

1. Should control of the well be considered lost and ignition considered, take care to protect against exposure to Sulfur Dioxide (SO₂). Intentional ignition must be coordinated with the NMOCD and local officials. Additionally, the NM State Police may become involved. NM State Police shall be the Incident Command on scene of any major release. Take care to protect downwind whenever there is an ignition of the gas

Contacting Authorities

1. Coterra personnel must liaise with local and state agencies to ensure a proper response to a major release. Additionally, the OCD must be notified of the release as soon as possible but no later than 4 hours.
2. Agencies will ask for information such as type and volume of release, wind direction, location of release, etc. Be prepared with all information available including directions to site. The following call list of essential and potential responders has been prepared for use during a release. Coterra's response must be in coordination with the State of New Mexico's "Hazardous Materials Emergency Response Plan" (HMER).

Coterra: H2S Plan

Emergency Contacts

Coterra Energy

Charlie Pritchard: Drilling Operations Manager: 432 – 238 – 7084

Darrell Kelly: Vice President EHS: 281 – 589 – 5795

Third Party

PERMIAN REGION CONTACT NUMBERS					
CALL 911					
Air Ambulance Services					
Reeves County Medical - Pecos, TX		432-447-3551			
Aero Care - Midland, TX		800-627-2376			
Tri State Care Flight- Artesia, NM		800-800-0900			
Air Methods - Hobbs, NM		800-242-6199			
Fire / Police / Medical Care					
Sheriff's Office		Fire Departments		Hospital / Medical Care Facilities	
Andrews County	432-523-5545	Andrews	432-523-3111	Permian Regional Med.	432-523-2200
Reagan County	325-884-2929	Big Lake	325-884-3650	Reagan Memorial Hosp.	325-884-2561
Howard County	432-264-2244	Big Springs	432-264-2303	Scenic Mountain Med Ctr	432-263-1211
Terry County	806-637-2212	Brownfield	806-637-6633		
Crane County	432-558-3571	Crane	432-558-2361	Crane Memorial Hosp.	432-558-3555
Val Verde County	830-774-7513	Del Rio	830-774-8648	Val Verde Regional Med.	830-775-8566
		Denver City	806-592-3516	Yoakum County Hospital	806-592-2121
Pecos County	432-336-3521	Ft Stockton	432-336-8525		
Glasscock County	432-354-2361	Garden City			
Winkler County	432-586-3461	Kernit	432-586-2577	Winkler County Memorial	432-586-5864
		McCamey	432-652-8232	McCamey Hospital	432-652-8626
Loving County	432-377-2411	Mentone			
Irion County	325-835-2551	Mertzton			
Ward County	432-943-6703	Monahans	432-943-2211	Ward Memorial Hospital	432-943-2511
Ector County	432-335-3050	Odessa	432-335-4650	Odessa Regional Hosp.	432-582-8340
Crocket County	325-392-2661	Ozona	325-392-2626		
Reeves County	432-445-4901	Pecos	505-757-6511	Reeves County Hospital	432-447-3551
Yoakum County	806-456-2377	Plains	806-456-2288		
Garza County	806-495-3595	Post			
Upton County	432-693-2422	Rankin			
Coke County	915-453-2717	Robert Lee			
		Roscoe	325-766-3931		
Hockley County	806-894-3126	Levelland	806-894-3155	Covenant Health	806-894-4963
Tom Green County	325-655-8111	San Angelo	325-657-4355	San Angelo Comm. Med.	325-949-9511
Gaines County	432-758-9871	Seminole	432-758-3621	Memorial Hospital	432-758-5811
Terrell County	432-345-2525	Sanderson			
Scurry County	325-573-3551	Snyder	325-573-3546	DM Cogdell Memorial	325-573-6374
Sterling County	325-378-4771	Sterling City			
Nolan County	325-235-5471	Sweetwater	325-235-8130	Rolling Plains Memorial	325-235-1701
Culberson County	432-283-2060	Van Horn		Culberson Hospital	432-283-2760
New Mexico					
Lea County	505-396-3611	Knowles	505-392-7469	Lea Reg Med Ctr	575-492-5000
Eddy County	575-887-7551	Carlsbad	575-885-3125	Carlsbad Medical	575-887-4100
		Artesia	575-746-5050	Artesia Hospital	575-748-3333
Roosevelt County	575-356-4408				
Chaves County	575-624-7590				
Ground Ambulance Services					
Reeves County Medical		Pecos, TX		432-447-3551	

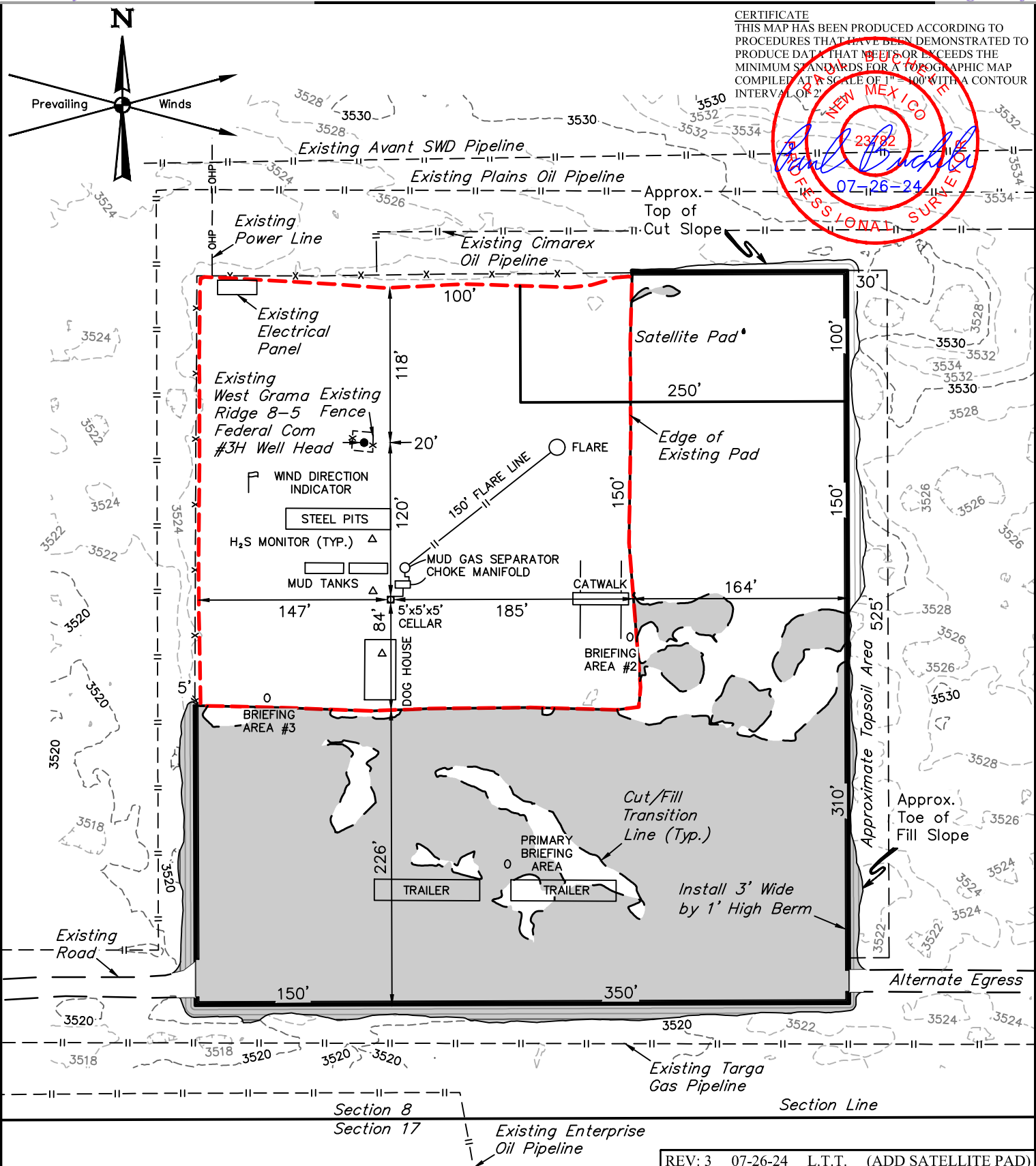

NOTES:
 • Contours shown at 2' intervals.

REV: 3 07-26-24 L.T.T. (ADD SATELLITE PAD)

CIMAREX ENERGY CO.

WEST GRAMA RIDGE 8-5 FEDERAL COM 153H
 397' FSL 560' FWL
 SW 1/4 SW 1/4, SECTION 8, T22S, R34E, N.M.P.M.
 LEA COUNTY, NEW MEXICO

SURVEYED BY	A.H.	03-21-24	SCALE
DRAWN BY	Z.L.	03-25-24	1" = 100'
TYPICAL RIG LAYOUT			EXHIBIT K

UINTAH
 ENGINEERING & LAND SURVEYING

UELS, LLC
 Corporate Office * 85 South 200 East
 Vernal, UT 84078 * (435) 789-1017

WEST GRAMA 8-5 FEDERAL COM 153H 397' FSL 560' FWL
WEST GRAMA 8-5 FEDERAL COM 154H 397' FSL 580' FWL
WEST GRAMA 8-5 FEDERAL COM 353H 457' FSL 640' FWL
WEST GRAMA 8-5 FEDERAL COM 302H 457' FSL 660' FWL
WEST GRAMA 8-5 FEDERAL COM 354H 457' FSL 680' FWL

CERTIFICATE
THIS MAP HAS BEEN PRODUCED ACCORDING TO PROCEDURES THAT HAVE BEEN DEMONSTRATED TO PRODUCE DATA THAT MEETS OR EXCEEDS THE MINIMUM STANDARDS FOR A TOPOGRAPHIC MAP COMPILED AT A SCALE OF 1" = 100' WITH A CONTOUR INTERVAL OF 2'

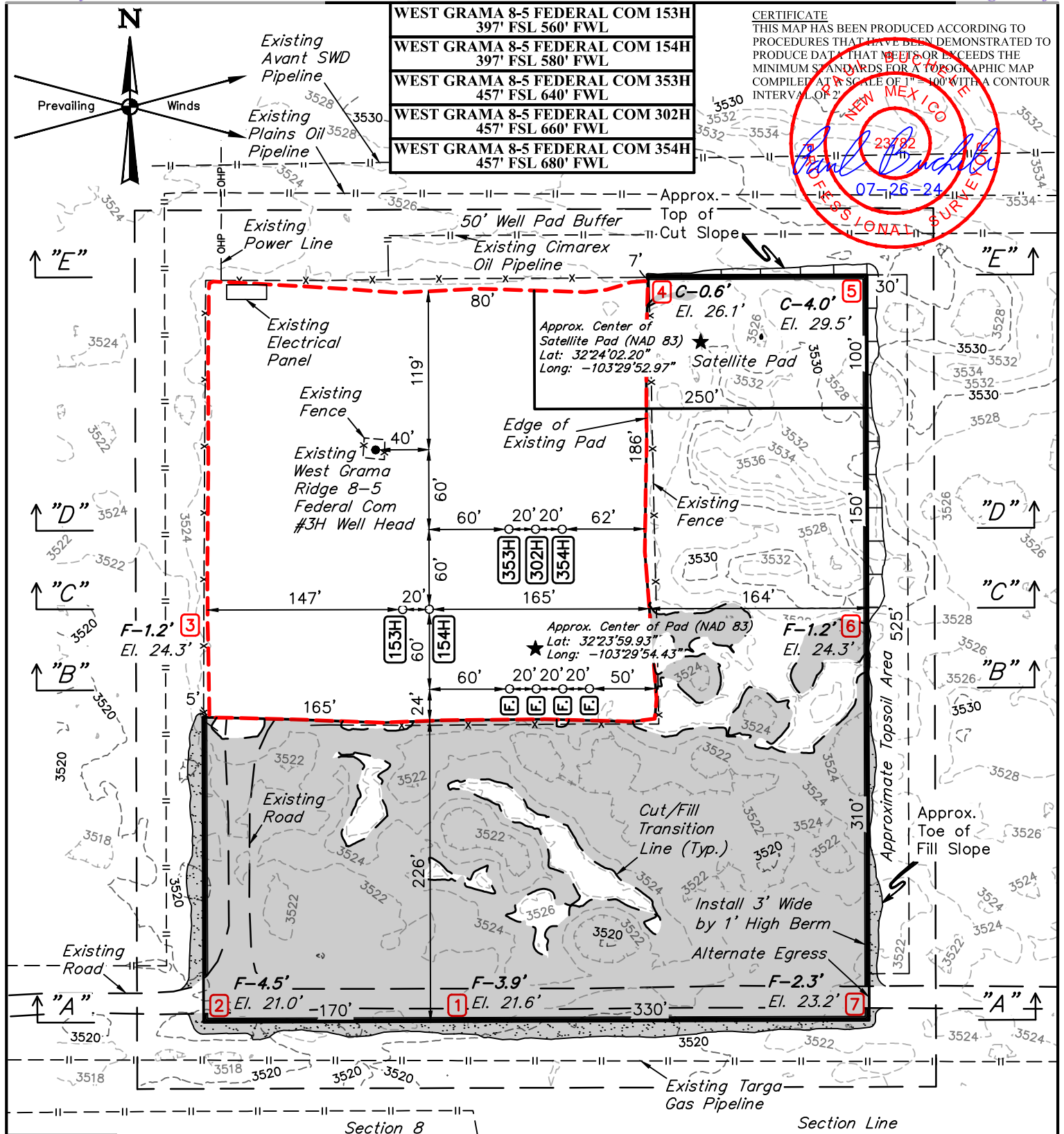
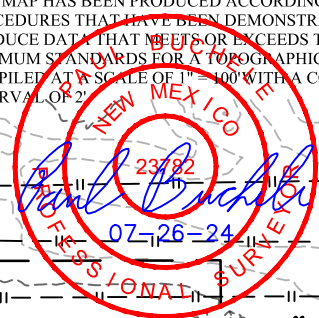

LEGEND:
F. = Future Well

FINISHED GRADE ELEVATION = 3525.5'

REV: 4 07-26-24 L.T.T. (ADD SATELLITE PAD & SHL'S)

- NOTES:
- Flare pit is to be located a min. of 100' from the wellhead.
 - Contours shown at 2' intervals.
 - Cut/Fill slopes 2:1 (Typ. except where noted)
 - Underground utilities shown on this sheet are for visualization purposes only, actual locations to be determined prior to construction.
 - Basis of Bearings is a Transverse Mercator Projection with a Central Meridian of W103°53'00" (NAD 83)

CIMAREX ENERGY CO.

WEST GRAMA 8-5 FED COM W2W2
367' FSL 660' FWL (APPROX. CENTER OF PAD)
SW 1/4 SW 1/4, SECTION 8, T22S, R34E, N.M.P.M.
LEA COUNTY, NEW MEXICO

SURVEYED BY	A.H.	03-21-24	SCALE
DRAWN BY	Z.L.	03-25-24	1" = 100'
LOCATION LAYOUT		EXHIBIT J	



UELS, LLC
 Corporate Office * 85 South 200 East
 Vernal, UT 84078 * (435) 789-1017



U.S. Department of the Interior
BUREAU OF LAND MANAGEMENT

SUPO Data Report

02/13/2025

APD ID: 10400100659

Submission Date: 08/26/2024

Highlighted data reflects the most recent changes

Operator Name: CIMAREX ENERGY COMPANY

Well Name: WEST GRAMA RIDGE 8-5 FEDERAL COM

Well Number: 153H

[Show Final Text](#)

Well Type: OIL WELL

Well Work Type: Drill

Section 1 - Existing Roads

Will existing roads be used? YES

Existing Road Map:

WEST_GRAMMA_RIDGE_8_5_FEDERAL_COM_W2W2_access_road_description_20240826093331.pdf

Existing Road Purpose: ACCESS

Row(s) Exist? YES

ROW ID(s)

ID: R35540

Do the existing roads need to be improved? NO

Existing Road Improvement Description:

Existing Road Improvement Attachment:

Section 2 - New or Reconstructed Access Roads

Will new roads be needed? NO

Section 3 - Location of Existing Wells

Existing Wells Map? YES

Attach Well map:

Operator Name: CIMAREX ENERGY COMPANY

Well Name: WEST GRAMA RIDGE 8-5 FEDERAL COM

Well Number: 153H

WEST_GRAMMA_RIDGE_8_5_FEDERAL_COM_W2W2_well_radius_map_20240826093354.pdf

Section 4 - Location of Existing and/or Proposed Production Facilities

Submit or defer a Proposed Production Facilities plan? DEFER

Estimated Production Facilities description: Satellite pad located on the Northeast corner of the pad.

Section 5 - Location and Types of Water Supply

Water Source Table

Water source type: RECYCLED

Water source use type: SURFACE CASING
INTERMEDIATE/PRODUCTION CASING

Source latitude: **Source longitude:**

Source datum:

Water source permit type: WATER RIGHT

Water source transport method: PIPELINE

Source land ownership: PRIVATE

Source transportation land ownership: PRIVATE

Water source volume (barrels): 5000

Source volume (acre-feet): 0.64446548

Source volume (gal): 210000

Water source and transportation

W_Grama_8_5_Fed_Com_2H_Water_Route_20240826105315.pdf

Water source comments:

New water well? N

New Water Well Info

Well latitude: **Well Longitude:** **Well datum:**

Well target aquifer:

Est. depth to top of aquifer(ft): **Est thickness of aquifer:**

Operator Name: CIMAREX ENERGY COMPANY
Well Name: WEST GRAMA RIDGE 8-5 FEDERAL COM **Well Number:** 153H

Aquifer comments:

Aquifer documentation:

Well depth (ft):

Well casing type:

Well casing outside diameter (in.):

Well casing inside diameter (in.):

New water well casing?

Used casing source:

Drilling method:

Drill material:

Grout material:

Grout depth:

Casing length (ft.):

Casing top depth (ft.):

Well Production type:

Completion Method:

Water well additional information:

State appropriation permit:

Additional information attachment:

Section 6 - Construction Materials

Using any construction materials: YES

Construction Materials description: Caliche will be obtained from the actual well site if available. If not available onsite caliche will be obtained for a pit located in NWNW Sec. 8 22S 34E or NWNW Sec 34 21S 34E

Construction Materials source location

Section 7 - Methods for Handling

Waste type: DRILLING

Waste content description: Drilling Fluids, drill cuttings, water and other waste produced from the well during drilling operations.

Amount of waste: 15000 barrels

Waste disposal frequency : Weekly

Safe containment description: Waste will be contained in accordance with best management practices.

Safe containmant attachment:

Waste disposal type: HAUL TO COMMERCIAL **Disposal location ownership:** COMMERCIAL FACILITY

Disposal type description:

Disposal location description: Haul to R360 commercial Disposal

Waste type: SEWAGE

Waste content description: Onsite human waste

Amount of waste: 300 gallons

Waste disposal frequency : Weekly

Safe containment description: A chemical porta-toilet will be furnished with the drilling rig.

Safe containmant attachment:

Operator Name: CIMAREX ENERGY COMPANY
Well Name: WEST GRAMA RIDGE 8-5 FEDERAL COM **Well Number:** 153H

Waste disposal type: HAUL TO COMMERCIAL FACILITY **Disposal location ownership:** PRIVATE

Disposal type description:

Disposal location description: The chemical porta-toilet wastes will be hauled to state approved disposal facility for treatment.

Waste type: GARBAGE

Waste content description: Garbage and trash produced during drilling and completion operations

Amount of waste: 32500 pounds

Waste disposal frequency : Weekly

Safe containment description: Garbage, trash, and other waste materials will be collected in a portable, self-contained, fully enclosed trash cage during operations. Trash will not be burned on location. All debris and other waste material not contained in the trash cage will be cleaned up and removed from the location immediately after removal of the drilling rig.

Safe containmant attachment:

Waste disposal type: HAUL TO COMMERCIAL FACILITY **Disposal location ownership:** PRIVATE

Disposal type description:

Disposal location description: All trash and waste material will be hauled to the Lea County Landfill.

Waste type: PRODUCED WATER

Waste content description: After first production, produced water will be confined to storage tanks on location and then disposed of in an approved location or recycled on location for future use.

Amount of waste: 400 barrels

Waste disposal frequency : Daily

Safe containment description: Flowline to an approved disposal location

Safe containmant attachment:

Waste disposal type: OFF-LEASE INJECTION **Disposal location ownership:** FEDERAL

Disposal type description:

Disposal location description: NGL disposal facility.

Reserve Pit

Reserve Pit being used? NO

Temporary disposal of produced water into reserve pit? NO

Reserve pit length (ft.) **Reserve pit width (ft.)**

Reserve pit depth (ft.) **Reserve pit volume (cu. yd.)**

Is at least 50% of the reserve pit in cut?

Reserve pit liner

Reserve pit liner specifications and installation description

Operator Name: CIMAREX ENERGY COMPANY

Well Name: WEST GRAMA RIDGE 8-5 FEDERAL COM

Well Number: 153H

Cuttings Area

Cuttings Area being used? NO

Are you storing cuttings on location? N

Description of cuttings location

Cuttings area length (ft.)

Cuttings area width (ft.)

Cuttings area depth (ft.)

Cuttings area volume (cu. yd.)

Is at least 50% of the cuttings area in cut?

WCuttings area liner

Cuttings area liner specifications and installation description

Section 8 - Ancillary

Are you requesting any Ancillary Facilities?: N

Ancillary Facilities

Comments:

Section 9 - Well Site

Well Site Layout Diagram:

WEST_GRAMA RIDGE_8_5_FEDERAL_COM_W2W2_location_layout_20240826094001.pdf

WEST_GRAMMA RIDGE_8_5_FEDERAL_COM_W2W2_archaeological_survey_boundary_20240826094023.pdf

WEST_GRAMMA RIDGE_8_5_FEDERAL_COM_W2W2_site_plan_20240826094024.pdf

Comments:

Section 10 - Plans for Surface Reclamation

Type of disturbance: New Surface Disturbance

Multiple Well Pad Name: W2W2

Multiple Well Pad Number: 153H

Recontouring

WEST_GRAMMA RIDGE_8_5_FEDERAL_COM_W2W2_interim_reclamation_plat_20240826094510.pdf

Drainage/Erosion control construction: Pad construction will include drainage control by rerouting drainages around the pad an installing culverts or low water crossings where needed. Erosion control techniques will be used where needed to minimize wind and water erosion and sedimentation prior to vegetation establishment.

Drainage/Erosion control reclamation: Area-wide drainage will be stabilized and restored so that surface runoff flows and gradients are returned to the condition present prior to development. Drainage basins will have similar features found in nearby, properly functioning basins.

Operator Name: CIMAREX ENERGY COMPANY

Well Name: WEST GRAMA RIDGE 8-5 FEDERAL COM **Well Number:** 153H

Well pad proposed disturbance (acres): 4.537	Well pad interim reclamation (acres): 2.41	Well pad long term disturbance (acres): 2.127
Road proposed disturbance (acres):	Road interim reclamation (acres): 0	Road long term disturbance (acres): 0
Powerline proposed disturbance (acres): 0	Powerline interim reclamation (acres): 0	Powerline long term disturbance (acres): 0
Pipeline proposed disturbance (acres): 0	Pipeline interim reclamation (acres): 0	Pipeline long term disturbance (acres): 0
Other proposed disturbance (acres): 0	Other interim reclamation (acres): 0	Other long term disturbance (acres): 0
Total proposed disturbance: 4.537	Total interim reclamation: 2.41	Total long term disturbance: 2.127

Disturbance Comments:

Reconstruction method: Areas to be reclaimed will be graded to approximate original contours and to blend in with adjacent topography. Graded surfaces will be suitable for the replacement of a uniform depth of topsoil, will promote cohesion between subsoil and topsoil layers, will reduce wind erosion, and will facilitate moisture capture. Specialized grading techniques may be applied, if warranted, and could include slope rounding, stair-step grading/terracing, and/or contour furrowing.

Topsoil redistribution: After compaction relief (ripping and discing) all topsoil will be redistributed on the reclaimed area to a pre-disturbance depth. Topsoil is typically redistributed with a scraper or front-end loader which leaves a friable surface to work with. Waterbars and erosion control devices will be installed on reclaimed areas, as necessary, to control topsoil erosion.

Soil treatment: As need, per state standards.

Existing Vegetation at the well pad: N/A

Existing Vegetation at the well pad

Existing Vegetation Community at the road: N/A

Existing Vegetation Community at the road

Existing Vegetation Community at the pipeline: N/A

Existing Vegetation Community at the pipeline

Existing Vegetation Community at other disturbances: N/A

Existing Vegetation Community at other disturbances

Non native seed used? N

Non native seed description:

Seedling transplant description:

Will seedlings be transplanted for this project? N

Seedling transplant description

Will seed be harvested for use in site reclamation? N

Seed harvest description:

Seed harvest description attachment:

Operator Name: CIMAREX ENERGY COMPANY

Well Name: WEST GRAMA RIDGE 8-5 FEDERAL COM

Well Number: 153H

Seed

Seed Table

Seed Summary

Total pounds/Acre:

Seed Type

Pounds/Acre

Seed reclamation

Operator Contact/Responsible Official

First Name: Laci

Last Name: Luig

Phone:

Email: laci.luig@coterra.com

Seedbed prep:

Seed BMP:

Seed method:

Existing invasive species? N

Existing invasive species treatment description:

Existing invasive species treatment

Weed treatment plan description: N/A

Weed treatment plan

Monitoring plan description: Monitoring will be done in accordance with the NMSLO Reclamation Guidelines

Monitoring plan

Success standards: Success Standards will be in accordance with the NMSLO Reclamation Guidelines.

Pit closure description: N/A

Pit closure attachment:

Section 11 - Surface Ownership

Disturbance type: WELL PAD

Describe:

Surface Owner: STATE GOVERNMENT

Other surface owner description:

BIA Local Office:

Operator Name: CIMAREX ENERGY COMPANY

Well Name: WEST GRAMA RIDGE 8-5 FEDERAL COM

Well Number: 153H

BOR Local Office:

COE Local Office:

DOD Local Office:

NPS Local Office:

State Local Office: SANTA FE

Military Local Office:

USFWS Local Office:

Other Local Office:

USFS Region:

USFS Forest/Grassland:

USFS Ranger District:

Section 12 - Other

Right of Way needed? N

Use APD as ROW?

ROW Type(s):

ROW

SUPO Additional Information:

Use a previously conducted onsite? N

Previous Onsite information:

Other SUPO



Borehole: West Grama Ridge 8-5 Federal Com 153H	Well: West Grama Ridge 8-5 Federal Com 153H	Field: NM Lea County (NAD 83)	Structure: Coterra - West Grama Ridge 8-5 Federal Com Pads
---	---	---	--

Gravity & Magnetic Parameters	Surface Location	NAD83 New Mexico State Plane, Eastern Zone, US Feet	Miscellaneous
Model: HDGM 2024 MagDec: 6.192°	Dip: 59.98° FS: 47446.377nT	Date: 16-Aug-2024 Gravity FS: 998.476mgn (9.80665 Based)	Lat: N 32 24 0.22 Lon: W 103 29 55.59
		Northing: 510278.9ftUS Easting: 798914.64ftUS	Grid Conv: 0.4472° Scale Fact: 0.99998507
			Slot: West Grama Ridge 8-5 Federal Com 153H Plan: Coterra West Grama Ridge 8-5 Federal Com 153H Rev0 kFc 16Aug24
			TVD Ref: RKB (3548.500 ft above MSL)

Critical Point	MD	INCL	AZIM	TVD	VSEC	N(+)/S(-)	E(+)/W(-)	DLS
SHL [397' FSL, 560' FWL]	0.00	0.00	0.00	0.00	0.00	0.00	0.00	
Rustler	1655.00	0.00	144.39	1655.00	0.00	0.00	0.00	0.00
A3 Top	1720.00	0.00	144.39	1720.00	0.00	0.00	0.00	0.00
Nudge, Build 2"/100ft	1800.00	0.00	144.39	1800.00	0.00	0.00	0.00	0.00
A3 Base	1840.00	0.80	144.39	1840.00	-0.23	-0.23	0.16	2.00
Hold	2100.03	6.00	144.39	2099.48	-12.81	-12.76	9.14	2.00
Salado	2110.61	6.00	144.39	2110.00	-13.72	-13.66	9.78	0.00
Lamar	5177.41	6.00	144.39	5160.00	-275.42	-274.30	196.47	0.00
Bell Canyon	5227.69	6.00	144.39	5210.00	-279.71	-278.57	199.54	0.00
Drop 2"/100ft	5271.51	6.00	144.39	5253.59	-283.45	-282.29	202.20	0.00
Hold	5571.54	0.00	144.39	5553.07	-296.27	-295.05	211.34	2.00
Cherry Canyon	5878.47	0.00	144.39	5860.00	-296.27	-295.05	211.34	0.00
Brushy Canyon	7108.47	0.00	144.39	7090.00	-296.27	-295.05	211.34	0.00
Basal Brushy Canyon	8418.47	0.00	144.39	8400.00	-296.27	-295.05	211.34	0.00
Bone Springs Lime	8648.47	0.00	144.39	8630.00	-296.27	-295.05	211.34	0.00
Leonard	8813.47	0.00	144.39	8795.00	-296.27	-295.05	211.34	0.00
Avalon	8968.47	0.00	144.39	8950.00	-296.27	-295.05	211.34	0.00
KOP, Build 10"/100ft	9326.54	0.00	144.39	9308.07	-296.27	-295.05	211.34	0.00
1st BS SS	9786.23	45.97	359.67	9720.00	-121.55	-120.34	210.34	10.00
Build 5"/100ft	10076.54	75.00	359.67	9861.50	128.40	129.60	208.90	10.00
Landing Point	10341.08	88.23	359.67	9900.00	389.53	390.73	207.40	5.00
Section 8-5 Line Cross	14841.00	88.23	359.67	10039.23	4887.29	4888.42	181.54	0.00
West Grama Ridge 8-5 Federal Com 153H - BHL [100'FNL, 770'FWL]	20037.42	88.23	359.67	10200.00	10081.22	10082.26	151.67	0.00

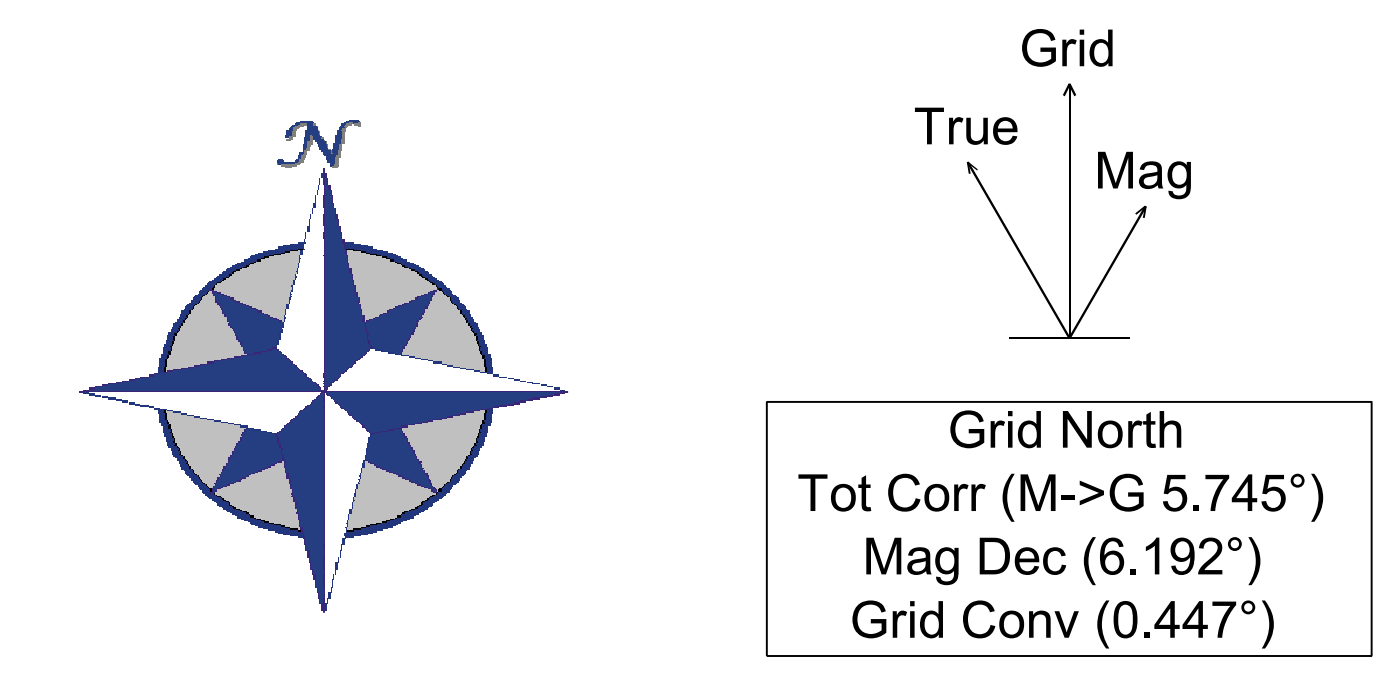

CONTROLLED	
Plan ref	Coterra West Grama Ridge 8-5 Federal Com 153H Rev0 kFc 16Aug24
Drawing ref	
Copy number	of 3
Date	16-Aug-2024
1 Client	
2 Client	
3 Office	
4 Office	
Copy number	for

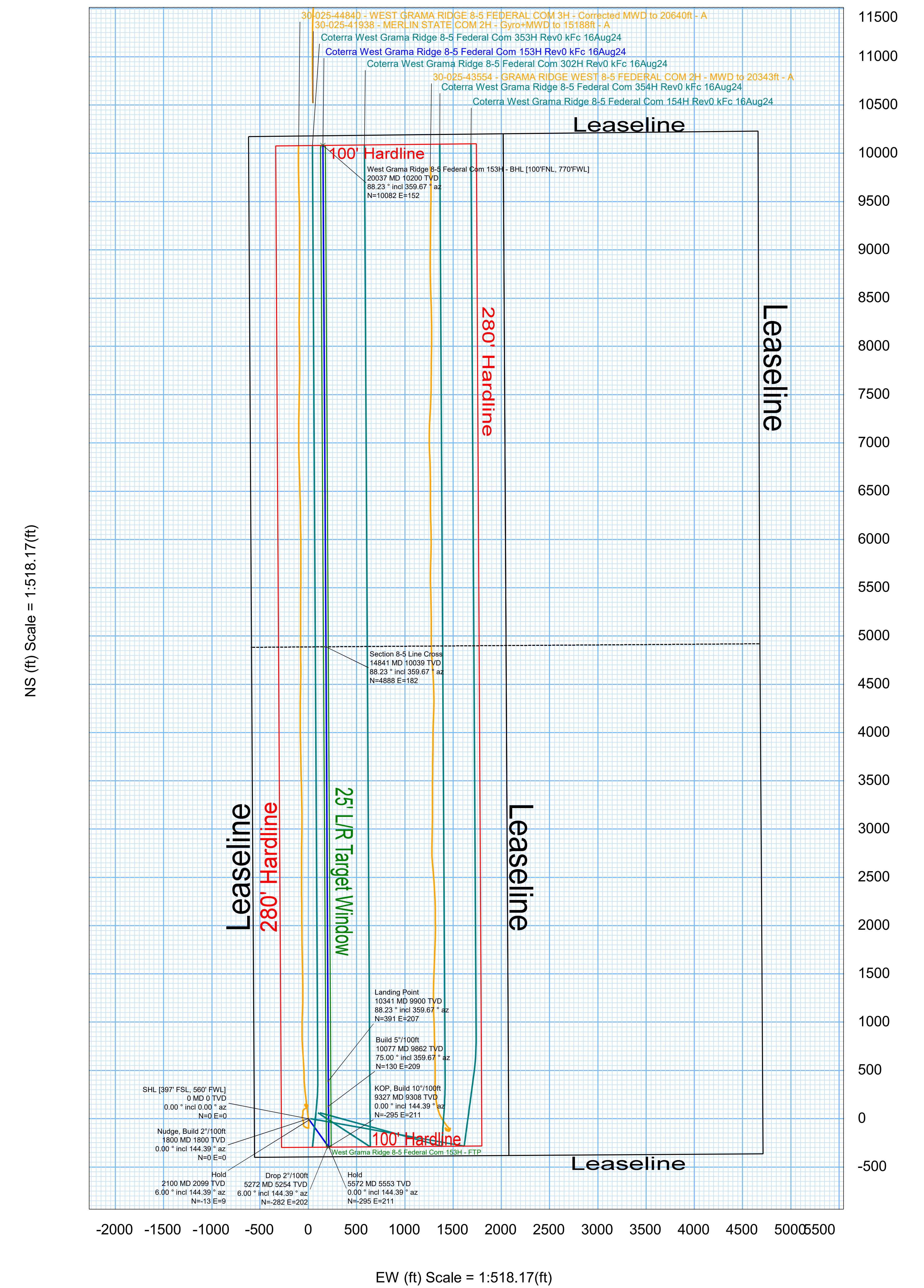
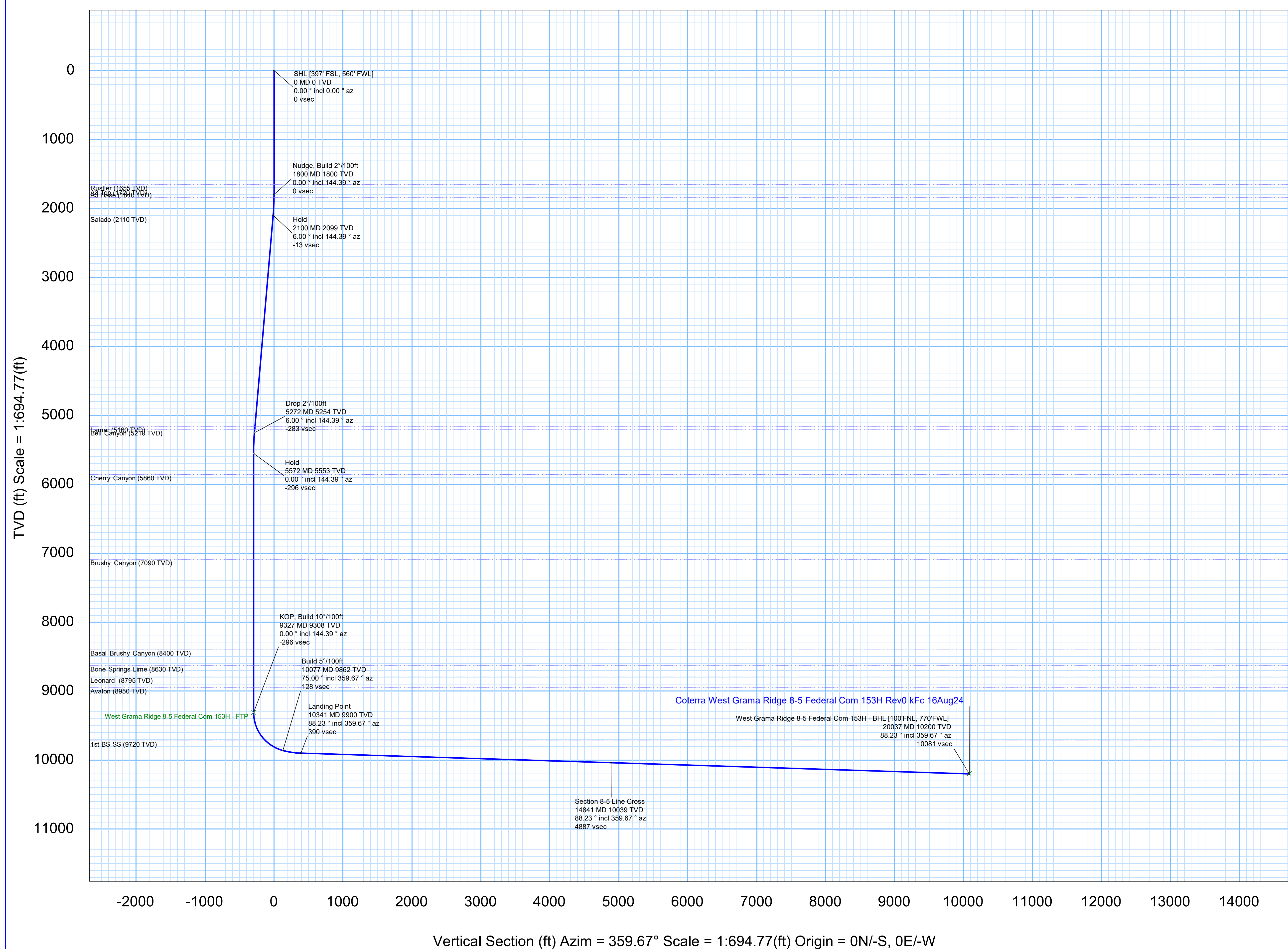

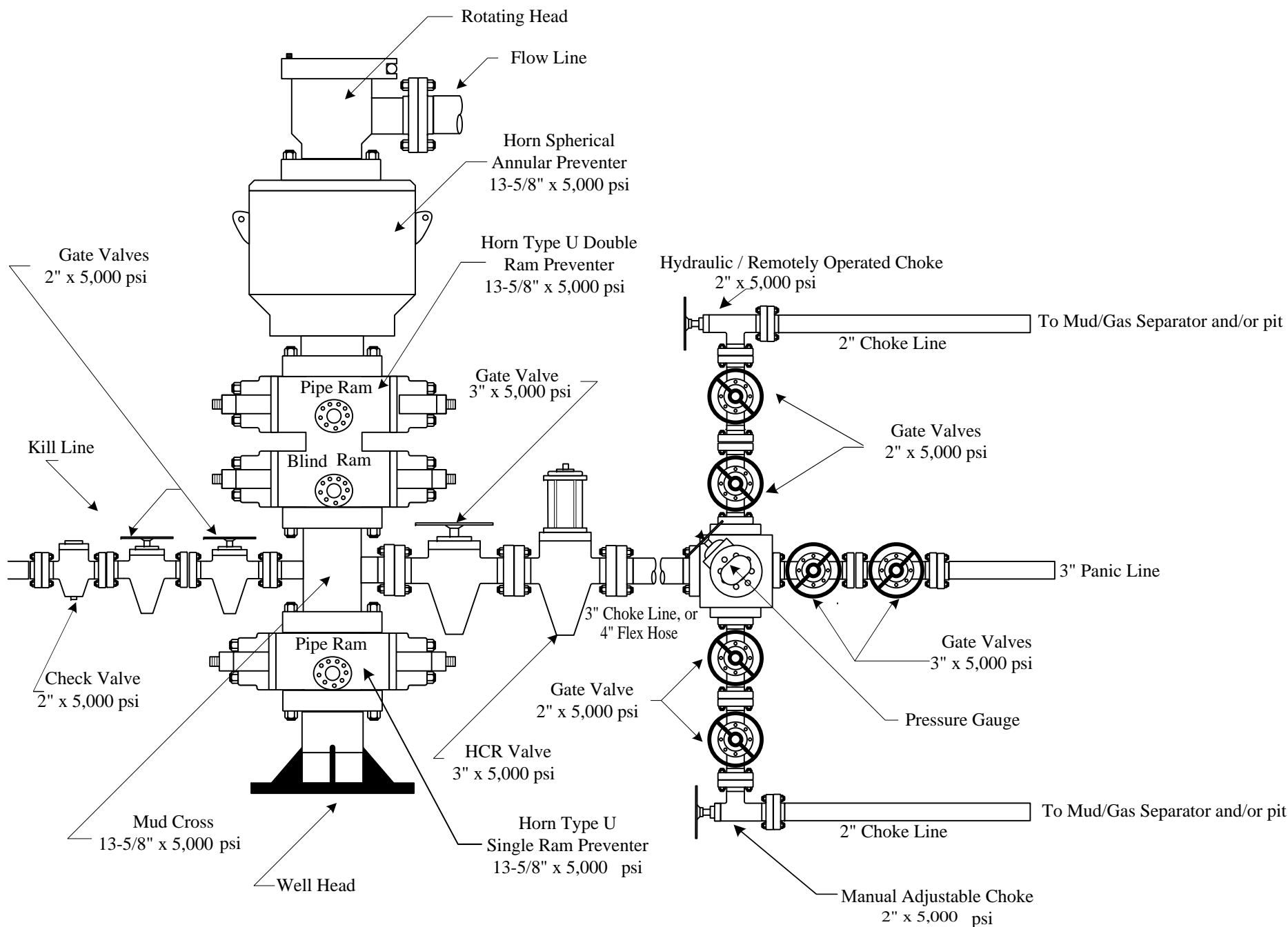

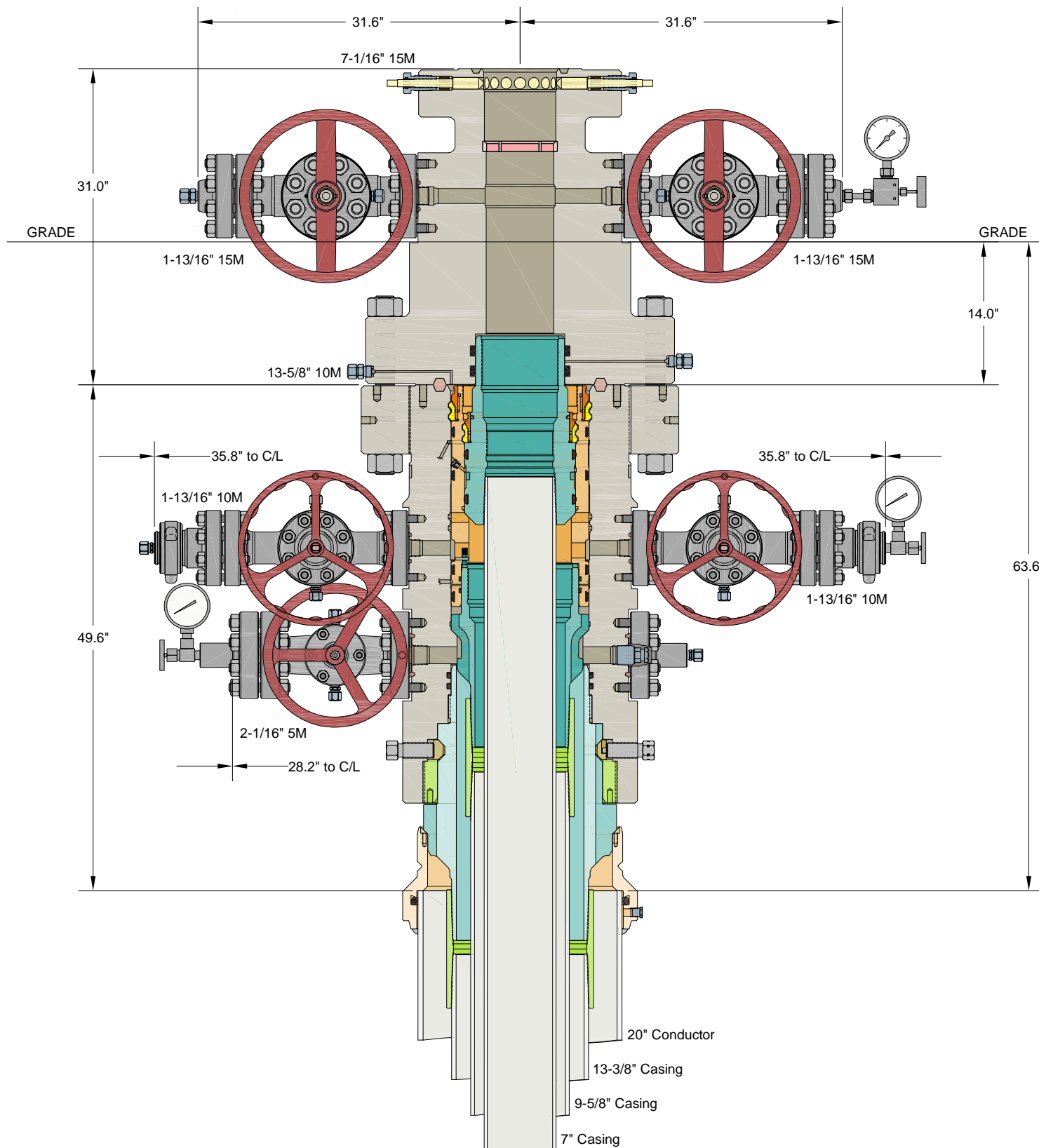

INFORMATION CONTAINED HEREIN IS THE PROPERTY OF CACTUS WELLHEAD, LLC. REPRODUCTION, DISCLOSURE, OR USE THEREOF IS PERMISSIBLE ONLY AS PROVIDED BY CONTRACT OR AS EXPRESSLY AUTHORIZED BY CACTUS WELLHEAD, LLC.

ALL DIMENSIONS APPROXIMATE

CACTUS WELLHEAD LLC

CIMAREX
HOBBS, NM

20" x 13-3/8" x 9-5/8" x 7" MBU-3T-CFL-R-DBLO-SF Wellhead Sys.
With 13-5/8" 10M x 7-1/16" 15M CTH-DBLHPS Tubing Head
And 9-5/8" Fluted & 7" One Piece Mandrel Casing Hangers

DRAWN	VJK	01FEB24
APPRV		
DRAWING NO.	HBE0001053	

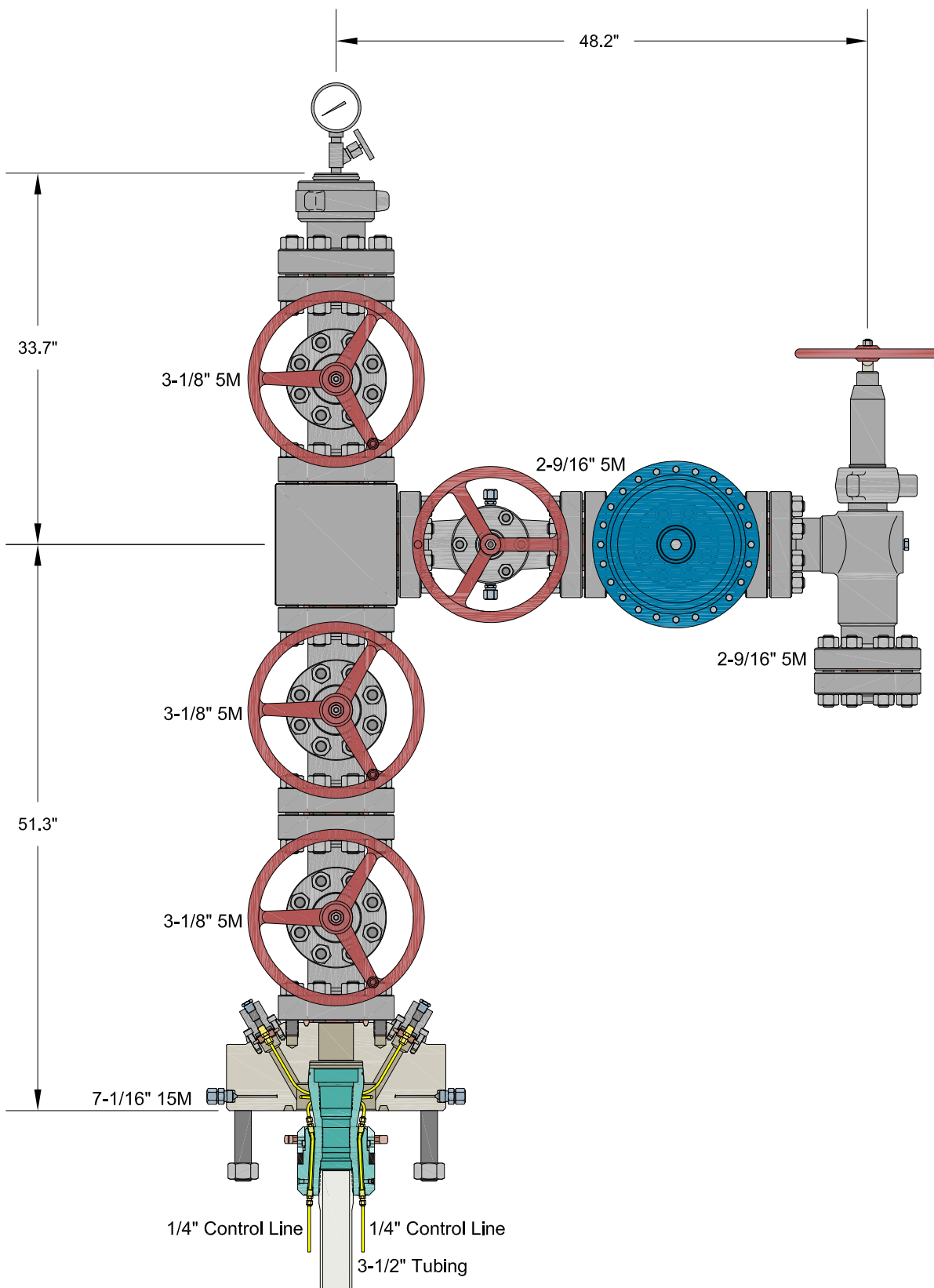

INFORMATION CONTAINED HEREIN IS THE PROPERTY OF CACTUS WELLHEAD, LLC. REPRODUCTION, DISCLOSURE, OR USE THEREOF IS PERMISSIBLE ONLY AS PROVIDED BY CONTRACT OR AS EXPRESSLY AUTHORIZED BY CACTUS WELLHEAD, LLC.

ALL DIMENSIONS APPROXIMATE

CACTUS WELLHEAD LLC

CIMAREX
HOBBS, NM

7-1/16" 15M x 3-1/8" x 2-9/16" 5M Production Tree Assembly
With 7-1/16" 15M x 3-1/8" 5M T40-CCL Tubing Head Adapter
And 7-1/16" x 3-1/2" T40-CCL Tubing Hanger

DRAWN	VJK	01SEP23
APPRV		
DRAWING NO.	HBE0001017	

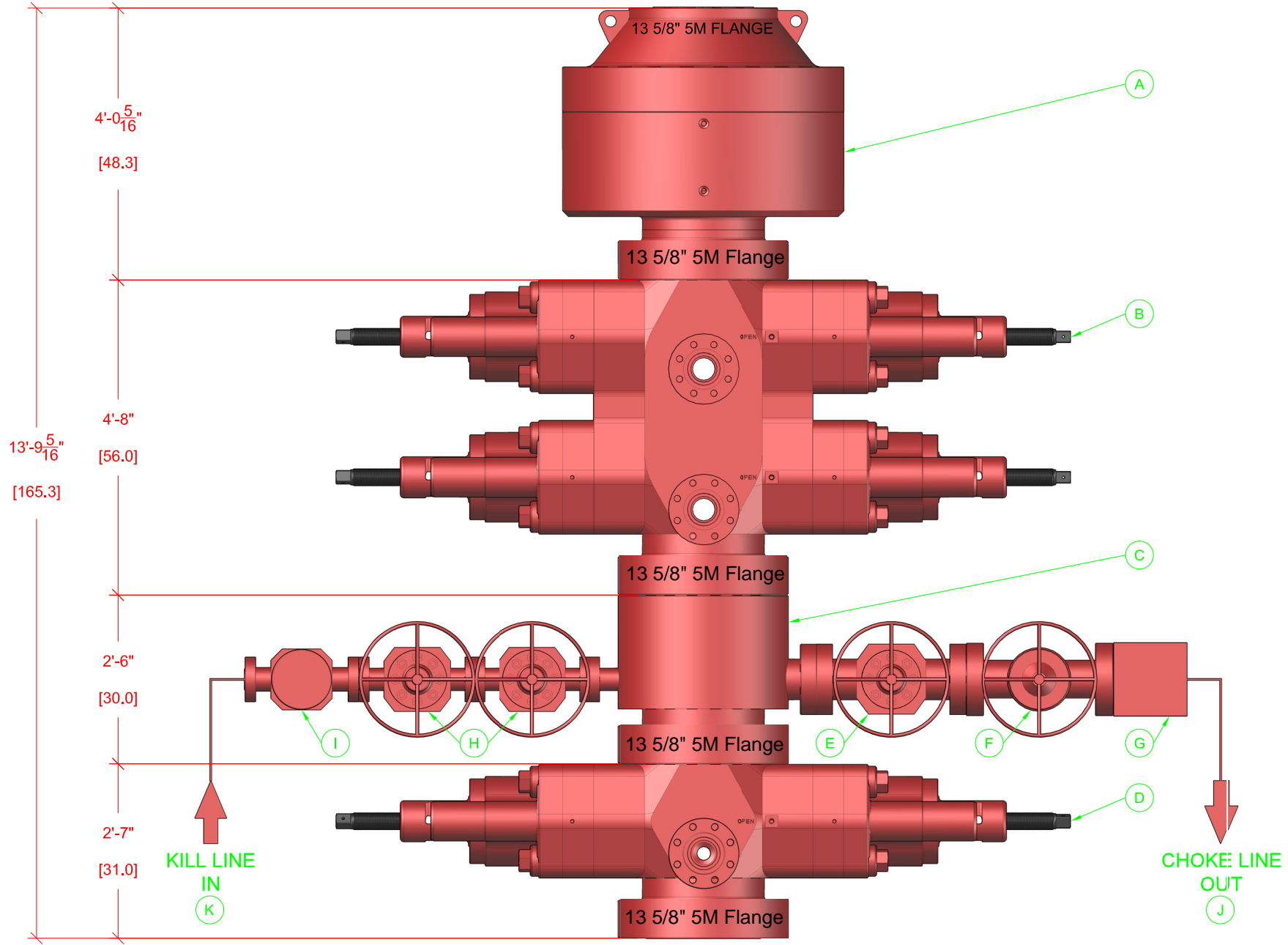

BOP EQUIPMENT INFORMATION

DESCRIPTION	MODEL	QTY
ANNULAR BOP	13 5/8" 5M	1
DOUBLE RAM BOP	13 5/8" 5M TYPE-U	1
MUD CROSS	13 5/8" 5M	1
SINGLE RAM BOP	13 5/8" 5M TYPE-U	1
GATE VALVE	4 1/2" 5M FC MANUAL	1

Sante Fe Main Office
Phone: (505) 476-3441

General Information
Phone: (505) 629-6116

Online Phone Directory
<https://www.emnrd.nm.gov/ocd/contact-us>

State of New Mexico
Energy, Minerals and Natural Resources
Oil Conservation Division
1220 S. St Francis Dr.
Santa Fe, NM 87505

CONDITIONS

Action 432748

CONDITIONS

Operator: CIMAREX ENERGY CO. 6001 Deauville Blvd Midland, TX 79706	OGRID: 215099
	Action Number: 432748
	Action Type: [C-101] BLM - Federal/Indian Land Lease (Form 3160-3)

CONDITIONS

Created By	Condition	Condition Date
amydoebele2024	Cement is required to circulate on both surface and intermediate1 strings of casing.	2/17/2025
amydoebele2024	If cement does not circulate on any string, a Cement Bond Log (CBL) is required for that string of casing.	2/17/2025
pkautz	File As Drilled C-102 and a directional Survey with C-104 completion packet.	3/5/2025
pkautz	Once the well is spud, to prevent ground water contamination through whole or partial conduits from the surface, the operator shall drill without interruption through the fresh water zone or zones and shall immediately set in cement the water protection string.	3/5/2025
pkautz	Oil base muds are not to be used until fresh water zones are cased and cemented providing isolation from the oil or diesel. This includes synthetic oils. Oil based mud, drilling fluids and solids must be contained in a steel closed loop system.	3/5/2025