

State of New Mexico
Energy, Minerals and Natural Resources

Office
District I - (575) 393-6161
1625 N. French Dr., Hobbs, NM 88240
District II - (575) 748-1283
811 S. First St., Artesia, NM 88210
District III - (505) 334-6178
1000 Rio Brazos Rd., Aztec, NM 87410
District IV - (505) 476-3460
1220 S. St. Francis Dr., Santa Fe, NM
87505

OIL CONSERVATION DIVISION
1220 South St. Francis Dr.
Santa Fe, NM 87505

WELL API NO.
30-025-04324
5. Indicate Type of Lease
STATE [] FEE [X]
6. State Oil & Gas Lease No.
7. Lease Name or Unit Agreement Name
Eunice Monument South Unit
8. Well Number
109
9. OGRID Number 330679
10. Pool name or Wildcat
Eunice Monument; Grayburg-San Andres
11. Elevation (Show whether DR, RKB, RT, GR, etc.)

SUNDRY NOTICES AND REPORTS ON WELLS
(DO NOT USE THIS FORM FOR PROPOSALS TO DRILL OR TO DEEPEN OR PLUG BACK TO A
DIFFERENT RESERVOIR. USE "APPLICATION FOR PERMIT" (FORM C-101) FOR SUCH
PROPOSALS.)
1. Type of Well: Oil Well [X] Gas Well [] Other []
2. Name of Operator
Empire Petroleum Corporation - New Mexico
3. Address of Operator
2200 S. Utica Place Suite 150, Tulsa, Oklahoma 74114
4. Well Location
Unit Letter H : 1980 feet from the South line and 660 feet from the East line
Section 25 Township 20S Range 36E NMPM County Lea
11. Elevation (Show whether DR, RKB, RT, GR, etc.)

12. Check Appropriate Box to Indicate Nature of Notice, Report or Other Data

NOTICE OF INTENTION TO:
PERFORM REMEDIAL WORK [X] PLUG AND ABANDON []
TEMPORARILY ABANDON [] CHANGE PLANS []
PULL OR ALTER CASING [] MULTIPLE COMPL []
DOWNHOLE COMMINGLE []
CLOSED-LOOP SYSTEM []
OTHER: []
SUBSEQUENT REPORT OF:
REMEDIAL WORK [] ALTERING CASING []
COMMENCE DRILLING OPNS. [] P AND A []
CASING/CEMENT JOB []
OTHER: []

13. Describe proposed or completed operations. (Clearly state all pertinent details, and give pertinent dates, including estimated date of starting any proposed work). SEE RULE 19.15.7.14 NMAC. For Multiple Completions: Attach wellbore diagram of proposed completion or recompletion.

- 1. MIRU WOR.
2. Unhang HH, PU on rod string, and POOH to rod part.
3. PU and MU fishing tools. TIH to fish and latch on.
4. Unseat pump and POOH with fish.
5. RIH with redressed pump and rod string. Seat pump.
6. Load and test tubing.
7. Notify NMOCD.
8. RDMO.
9. RTP.

Spud Date:

[Empty box for Spud Date]

Rig Release Date:

[Empty box for Rig Release Date]

I hereby certify that the information above is true and complete to the best of my knowledge and belief.

SIGNATURE Nathan Sandel TITLE Production Engineer DATE 06/09/2025

Type or print name Nathan Sandel E-mail address: nsandel@empirepetrocorp.com PHONE: 918-404-4202

For State Use Only

APPROVED BY: TITLE DATE

Conditions of Approval (if any):

Current and Proposed WBD

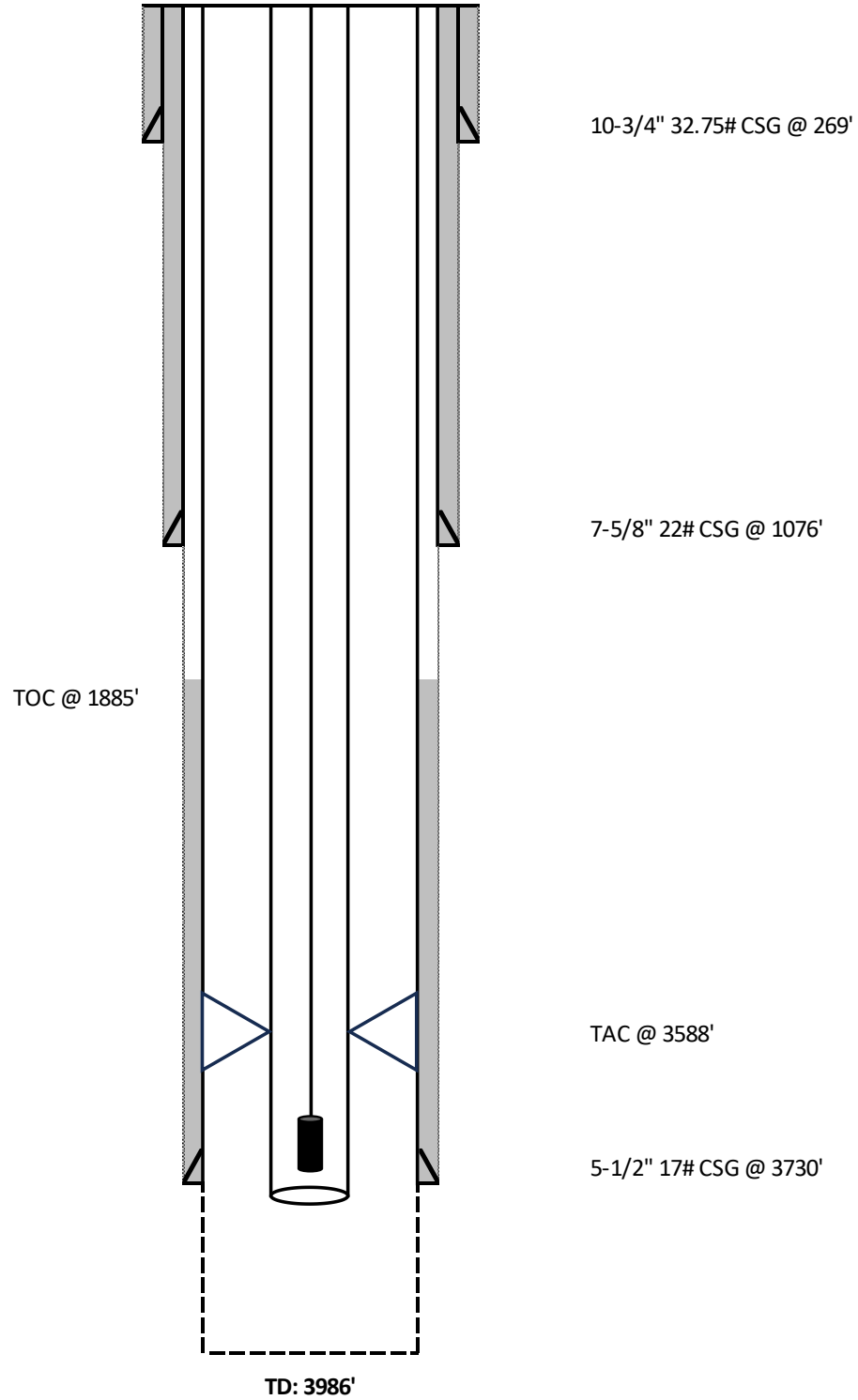

Sante Fe Main Office
Phone: (505) 476-3441

General Information
Phone: (505) 629-6116

Online Phone Directory
<https://www.emnrd.nm.gov/ocd/contact-us>

State of New Mexico
Energy, Minerals and Natural Resources
Oil Conservation Division
1220 S. St Francis Dr.
Santa Fe, NM 87505

CONDITIONS

Action 471894

CONDITIONS

Operator: Empire New Mexico LLC 2200 S. Utica Place Tulsa, OK 74114	OGRID: 330679
	Action Number: 471894
	Action Type: [C-103] NOI Workover (C-103G)

CONDITIONS

Created By	Condition	Condition Date
gcordero	None	12/5/2025