

Form 3160-5
(October 2024)

UNITED STATES
DEPARTMENT OF THE INTERIOR
BUREAU OF LAND MANAGEMENT

FORM APPROVED
OMB No. 1004-0220
Expires: October 31, 2027

SUNDRY NOTICES AND REPORTS ON WELLS
Do not use this form for proposals to drill or to re-enter an abandoned well. Use Form 3160-3 (APD) for such proposals.

5. Lease Serial No.	NMNM111533
6. If Indian, Allottee or Tribe Name	

SUBMIT IN TRIPLICATE - Other instructions on page 2		7. If Unit of CA/Agreement, Name and/or No.
1. Type of Well <input checked="" type="checkbox"/> Oil Well <input type="checkbox"/> Gas Well <input type="checkbox"/> Other		8. Well Name and No. SWEET TEA EBS FEDERAL COM/552H
2. Name of Operator MARATHON OIL PERMIAN LLC		9. API Well No. 3001555630
3a. Address 990 TOWN & COUNTRY BLVD, HOUSTON, TX	3b. Phone No. (include area code) (713) 296-2113	10. Field and Pool or Exploratory Area WILLOW LAKE/BONE SPRING
4. Location of Well (Footage, Sec., T.,R.,M., or Survey Description) SEC 31/T24S/R29E/1PM		11. Country or Parish, State EDDY/NM

12. CHECK THE APPROPRIATE BOX(ES) TO INDICATE NATURE OF NOTICE, REPORT OR OTHER DATA

TYPE OF SUBMISSION	TYPE OF ACTION			
<input checked="" type="checkbox"/> Notice of Intent	<input type="checkbox"/> Acidize	<input type="checkbox"/> Deepen	<input type="checkbox"/> Production (Start/Resume)	<input type="checkbox"/> Water Shut-Off
<input type="checkbox"/> Subsequent Report	<input type="checkbox"/> Alter Casing	<input type="checkbox"/> Hydraulic Fracturing	<input type="checkbox"/> Reclamation	<input type="checkbox"/> Well Integrity
<input type="checkbox"/> Final Abandonment Notice	<input type="checkbox"/> Casing Repair	<input type="checkbox"/> New Construction	<input type="checkbox"/> Recomplete	<input type="checkbox"/> Other
	<input checked="" type="checkbox"/> Change Plans	<input type="checkbox"/> Plug and Abandon	<input type="checkbox"/> Temporarily Abandon	
	<input type="checkbox"/> Convert to Injection	<input type="checkbox"/> Plug Back	<input type="checkbox"/> Water Disposal	

13. Describe Proposed or Completed Operation: Clearly state all pertinent details, including estimated starting date of any proposed work and approximate duration thereof. If the proposal is to deepen directionally or recomplete horizontally, give subsurface locations and measured and true vertical depths of all pertinent markers and zones. Attach the Bond under which the work will be performed or provide the Bond No. on file with BLM/BIA. Required subsequent reports must be filed within 30 days following completion of the involved operations. If the operation results in a multiple completion or recompletion in a new interval, a Form 3160-4 must be filed once testing has been completed. Final Abandonment Notices must be filed only after all requirements, including reclamation, have been completed and the operator has determined that the site is ready for final inspection.)

MARATHON OIL PERMIAN LLC, respectfully requests approval for the following changes to the original approved APD.

APD ID: 10400095883
API #30-015-55630

Summary of Changes:

No changes in targets
MD at TD changed to 16,508'
TVD of target changed to 8,834'

BHL CHANGES: From: 100' FSL & 990' FWL Section 6. T25S. R29E.

Continued on page 3 additional information

14. I hereby certify that the foregoing is true and correct. Name (Printed/Typed) MAYTE REYES / Ph: (281) 293-1000	Regulatory Analyst Title
Signature (Electronic Submission)	Date 02/13/2026

THE SPACE FOR FEDERAL OR STATE OFFICE USE

Approved by CHRISTOPHER WALLS / Ph: (575) 234-2234 / Approved	Petroleum Engineer Title	02/20/2026 Date
Conditions of approval, if any, are attached. Approval of this notice does not warrant or certify that the applicant holds legal or equitable title to those rights in the subject lease which would entitle the applicant to conduct operations thereon.	Office CARLSBAD	

Title 18 U.S.C Section 1001 and Title 43 U.S.C Section 1212, make it a crime for any person knowingly and willfully to make to any department or agency of the United States any false, fictitious or fraudulent statements or representations as to any matter within its jurisdiction.

(Instructions on page 2)

GENERAL INSTRUCTIONS

This form is designed for submitting proposals to perform certain well operations and reports of such operations when completed as indicated on Federal and Indian lands pursuant to applicable Federal law and regulations. Any necessary special instructions concerning the use of this form and the number of copies to be submitted, particularly with regard to local area or regional procedures and practices, are either shown below, will be issued by or may be obtained from the local Federal office.

SPECIFIC INSTRUCTIONS

Item 4 - Locations on Federal or Indian land should be described in accordance with Federal requirements. Consult the local Federal office for specific instructions.

Item 13: Proposals to abandon a well and subsequent reports of abandonment should include such special information as is required by the local Federal office. In addition, such proposals and reports should include reasons for the abandonment; data on any former or present productive zones or other zones with present significant fluid contents not sealed off by cement or otherwise; depths (top and bottom) and method of placement of cement plugs; mud or other material placed below, between and above plugs; amount, size, method of parting of any casing, liner or tubing pulled and the depth to the top of any tubing left in the hole; method of closing top of well and date well site conditioned for final inspection looking for approval of the abandonment. If the proposal will involve **hydraulic fracturing operations**, you must comply with 43 CFR 3162.3-3, including providing information about the protection of usable water. Operators should provide the best available information about all formations containing water and their depths. This information could include data and interpretation of resistivity logs run on nearby wells. Information may also be obtained from state or tribal regulatory agencies and from local BLM offices.

NOTICES

The privacy Act of 1974 and the regulation in 43 CFR 2.48(d) provide that you be furnished the following information in connection with information required by this application.

AUTHORITY: 30 U.S.C. 181 et seq., 351 et seq., 25 U.S.C. 396; 43 CFR 3160.

PRINCIPAL PURPOSE: The information is used to: (1) Evaluate, when appropriate, approve applications, and report completion of subsequent well operations, on a Federal or Indian lease; and (2) document for administrative use, information for the management, disposal and use of National Resource lands and resources, such as: (a) evaluating the equipment and procedures to be used during a proposed subsequent well operation and reviewing the completed well operations for compliance with the approved plan; (b) requesting and granting approval to perform those actions covered by 43 CFR 3162.3-2, 3162.3-3, and 3162.3-4; (c) reporting the beginning or resumption of production, as required by 43 CFR 3162.4-1(c) and (d) analyzing future applications to drill or modify operations in light of data obtained and methods used.

ROUTINE USES: Information from the record and/or the record will be transferred to appropriate Federal, State, local or foreign agencies, when relevant to civil, criminal or regulatory investigations or prosecutions in connection with congressional inquiries or to consumer reporting agencies to facilitate collection of debts owed the Government.

EFFECT OF NOT PROVIDING THE INFORMATION: Filing of this notice and report and disclosure of the information is mandatory for those subsequent well operations specified in 43 CFR 3162.3-2, 3162.3-3, 3162.3-4.

The Paperwork Reduction Act of 1995 requires us to inform you that:

The BLM collects this information to evaluate proposed and/or completed subsequent well operations on Federal or Indian oil and gas leases.

Response to this request is mandatory.

The BLM would like you to know that you do not have to respond to this or any other Federal agency-sponsored information collection unless it displays a currently valid OMB control number.

BURDEN HOURS STATEMENT: Public reporting burden for this form is estimated to average 8 hours per response, including the time for reviewing instructions, gathering and maintaining data, and completing and reviewing the form. Direct comments regarding the burden estimate or any other aspect of this form to U.S. Department of the Interior, Bureau of Land Management (1004-0137), Bureau Information Collection Clearance Officer (WO-630), 1849 C St., N.W., Mail Stop 401 LS, Washington, D.C. 20240

Additional Information

Additional Remarks

To: 50' FSL & 890' FWL Section 6. T25S. R29E.

C102 Attached.

NAME CHANGE:

From: SWEET TEA EBS FEDERAL COM 552H

To: SWEET TEA STATE COM 552H

C102 Attached.

DRILLING CHANGES:

Drilling program,

Directional Plan, AC Report, Bradenhead, Break Testing and Specs attached.

Location of Well

0. SHL: NESW / 2622 FSL / 1781 FWL / TWSP: 24S / RANGE: 29E / SECTION: 31 / LAT: 32.1736843 / LONG: -104.0264881 (TVD: 0 feet, MD: 0 feet)

PPP: NWSW / 2540 FSL / 990 FWL / TWSP: 24S / RANGE: 29E / SECTION: 31 / LAT: 32.1734581 / LONG: -104.0290457 (TVD: 9130 feet, MD: 9700 feet)

BHL: LOT 7 / 100 FSL / 990 FWL / TWSP: 25S / RANGE: 29E / SECTION: 6 / LAT: 32.1521571 / LONG: -104.0290794 (TVD: 9130 feet, MD: 16729 feet)

CONFIDENTIAL

Well Name: SWEET TEA EBS FEDERAL COM	Well Location: T24S / R29E / SEC 31 / NESW / 32.1736843 / -104.0264881	County or Parish/State: EDDY / NM
Well Number: 552H	Type of Well: OIL WELL	Allottee or Tribe Name:
Lease Number: NMNM111533	Unit or CA Name:	Unit or CA Number:
US Well Number: 3001555630	Operator: MARATHON OIL PERMIAN LLC	

Notice of Intent

Sundry ID: 2895690

Type of Submission: Notice of Intent

Type of Action: APD Change

Date Sundry Submitted: 02/12/2026

Time Sundry Submitted: 10:44

Date proposed operation will begin: 02/12/2026

Procedure Description: MARATHON OIL PERMIAN LLC, respectfully requests approval for the following changes to the original approved APD. APD ID: 10400095883 API #30-015-55630 Summary of Changes: No changes in targets MD at TD changed to 16,508' TVD of target changed to 8,834' BHL CHANGES: From: 100' FSL & 990' FWL Section 6. T25S. R29E. To: 50' FSL & 890' FWL Section 6. T25S. R29E. C102 Attached. NAME CHANGE: From: SWEET TEA EBS FEDERAL COM 552H To: SWEET TEA STATE COM 552H C102 Attached. DRILLING CHANGES: Drilling program, Directional Plan, AC Report, Bradenhead, Break Testing and Specs attached.

NOI Attachments

Procedure Description

- MRO_Sweet_Tea_State_Com_552H_C102_20260212103618.pdf
- BOP_Break_Testing_Documentation_6_07_23_20260212103452.pdf
- SWEET_TEA_FEDERAL_COM_552H_PERMIT_PLOT_20260212103452.pdf
- SWEET_TEA_FEDERAL_COM_552H_AC_REPORT_20260212103452.pdf
- MRO_Sweet_Tea_Federal_Com_552H_Drilling_Program_20260212103452.pdf
- Recommended_COP_Bradenhead_Procedure_20260212103452.pdf
- Wedge_513_7.625_0.375_P110_ICY_02202022_20260212103452.pdf
- Wedge_441_5.500_0.415_P110_CY_02202022_20260212103452.pdf

Well Name: SWEET TEA EBS
FEDERAL COM

Well Location: T24S / R29E / SEC 31 /
NESW / 32.1736843 / -104.0264881

County or Parish/State: EDDY /
NM

Well Number: 552H

Type of Well: OIL WELL

Allottee or Tribe Name:

Lease Number: NMNM111533

Unit or CA Name:

Unit or CA Number:

US Well Number: 3001555630

Operator: MARATHON OIL PERMIAN
LLC

TXP_BTC_5.500_0.415_P110_CY_02202022_20260212103452.pdf

API_BTC_7.625_0.375_L80ICY_01052024_20260212103451.pdf

10.75_45.5_J_55_BTC_Spec._Sheet_20260212103448.pdf

Conditions of Approval

Additional

SEC31_T24S_R29E_SWEET_TEA_EBS_FED_COM_Eddy__CONOCOPHILLIPS_COMPANY_46072_JS_20260220071437.pdf

SEC31_T24S_R29E_SWEET_TEA_EBS_FED_COM_Eddy__CONOCOPHILLIPS_COMPANY_46072_JS_B_20260220071437.pdf

SWEET_TEA_FEDERAL_COM_552H_COAs_20260220071437.pdf

Operator

I certify that the foregoing is true and correct. Title 18 U.S.C. Section 1001 and Title 43 U.S.C. Section 1212, make it a crime for any person knowingly and willfully to make to any department or agency of the United States any false, fictitious or fraudulent statements or representations as to any matter within its jurisdiction. Electronic submission of Sundry Notices through this system satisfies regulations requiring a

Operator Electronic Signature: MAYTE REYES

Signed on: FEB 13, 2026 07:25 AM

Name: MARATHON OIL PERMIAN LLC

Title: Regulatory Analyst

Street Address: 925 N ELDRIDGE PARKWAY

City: HOUSTON **State:** TX

Phone: (281) 293-1000

Email address: MAYTE.X.REYES@CONOCOPHILLIPS.COM

Field

Representative Name: Robyn Russell

Street Address: 600 W. Illinois Ave.

City: Midland **State:** TX **Zip:** 79701

Phone: (432)685-4385

Email address: robyn.m.russell@cop.com

BLM Point of Contact

BLM POC Name: CHRISTOPHER WALLS

BLM POC Title: Petroleum Engineer

BLM POC Phone: 5752342234

BLM POC Email Address: CWALLS@BLM.GOV

Disposition: Approved

Disposition Date: 02/20/2026

Signature: Chris Walls

C-102 Submit Electronically Via OCD Permitting	State of New Mexico Energy, Minerals & Natural Resources Department OIL CONSERVATION DIVISION	Revised July 9, 2024 Submittal Type: <input type="checkbox"/> Initial Submittal <input checked="" type="checkbox"/> Amended Report <input type="checkbox"/> As Drilled
---	--	--

WELL LOCATION INFORMATION

API Number 30-015-55630	Pool Code 64450	Pool Name WILLOW LAKE; BONE SPRING
Property Code	Property Name SWEET TEA STATE COM	Well Number #552H
OGRID No. 271817	Operator Name MARATHON OIL PERMIAN LLC	Ground Level Elevation 2,904'
Surface Owner: <input type="checkbox"/> State <input type="checkbox"/> Fee <input type="checkbox"/> Tribal <input checked="" type="checkbox"/> Federal		Mineral Owner: <input checked="" type="checkbox"/> State <input type="checkbox"/> Fee <input type="checkbox"/> Tribal <input checked="" type="checkbox"/> Federal

Surface Location

UL	Section	Township	Range	Lot	Ft. from N/S	Ft. from E/W	Latitude	Longitude	County
K	31	24S	29E		2,621' FSL	1,781' FWL	32.173684°	-104.026488°	EDDY

Bottom Hole Location

UL	Section	Township	Range	Lot	Ft. from N/S	Ft. from E/W	Latitude	Longitude	County
	6	25S	29E	LOT 7	50' FSL	890' FWL	32.152015°	-104.029403°	EDDY

Dedicated Acres 475.67	Infill or Defining Well Defining	Defining Well API 30-015-55630	Overlapping Spacing Unit (Y/N) N	Consolidation Code N/A
Order Numbers.			Well setbacks are under Common Ownership: <input checked="" type="checkbox"/> Yes <input type="checkbox"/> No	

Kick Off Point (KOP)

UL	Section	Township	Range	Lot	Ft. from N/S	Ft. from E/W	Latitude	Longitude	County
	31	24S	29E	LOT 3	2,540' FSL	890' FWL	32.173458°	-104.029369°	EDDY

First Take Point (FTP)

UL	Section	Township	Range	Lot	Ft. from N/S	Ft. from E/W	Latitude	Longitude	County
	31	24S	29E	LOT 3	2,540' FSL	890' FWL	32.173458°	-104.029369°	EDDY

Last Take Point (LTP)

UL	Section	Township	Range	Lot	Ft. from N/S	Ft. from E/W	Latitude	Longitude	County
	6	25S	29E	LOT 7	100' FSL	890' FWL	32.152153°	-104.029403°	EDDY

Unitized Area or Area of Uniform Interest COM	Spacing Unit Type <input type="checkbox"/> Horizontal <input type="checkbox"/> Vertical	Ground Floor Elevation: 2,904'
---	---	---------------------------------------

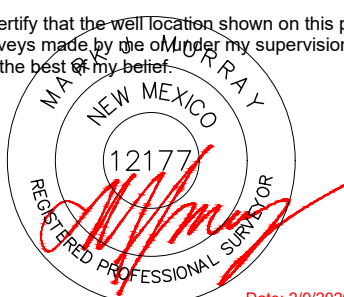
<p>OPERATOR CERTIFICATIONS</p> <p>I hereby certify that the information contained herein is true and complete to the best of my knowledge and belief, and, if the well is a vertical or directional well, that this organization either owns a working interest or unleased mineral interest in the land including the proposed bottom hole location or has a right to drill this well at this location pursuant to a contract with an owner of a working interest or unleased mineral interest, or to a voluntary pooling agreement or a compulsory pooling order heretofore entered by the division.</p> <p>If this well is a horizontal well, I further certify that this organization has received the consent of at least one lessee or owner of a working interest or unleased mineral interest in each tract (in the target pool or formation) in which any part of the well's completed interval will be located or obtained a compulsory pooling order from the division.</p>	<p>SURVEYOR CERTIFICATIONS</p> <p>I hereby certify that the well location shown on this plat was plotted from field notes of actual surveys made by me under my supervision, and that the same is true and correct to the best of my belief.</p> <div style="text-align: center;">  <p>Date: 2/9/2026</p> </div>
Signature <i>Mayte Reyes</i> Date 2/11/2026	Signature and Seal of Professional Surveyor
Printed Name Mayte Reyes	Certificate Number 12177 Date of Survey 2/9/2026 Revision Number 1
Email Address mayte.x.reyes@conocophillips.com	

Note: No allowable will be assigned to this completion until all interests have been consolidated or a non-standard unit has been approved by the division.

ACREAGE DEDICATION PLATS

This grid represents a standard section. You may superimpose a non-standard section, or larger area, over this grid. Operators must outline the dedicated acreage in a red box, clearly show the well surface location and bottom hole location, if it is directionally drilled, with the dimensions from the section lines in the cardinal directions. If this is a horizontal wellbore show on this plat the location of the First Take Point and Last Take Point, and the point within the Completed interval (other than the First Take Point or Last Take Point) that is closest to any outer boundary of the tract.

Surveyors shall use the latest United States government survey or dependent resurvey. Well locations will be in reference to the New Mexico Principal Meridian. If the land is not surveyed, contact the OCD Engineering Bureau. Independent subdivision surveys will not be acceptable.

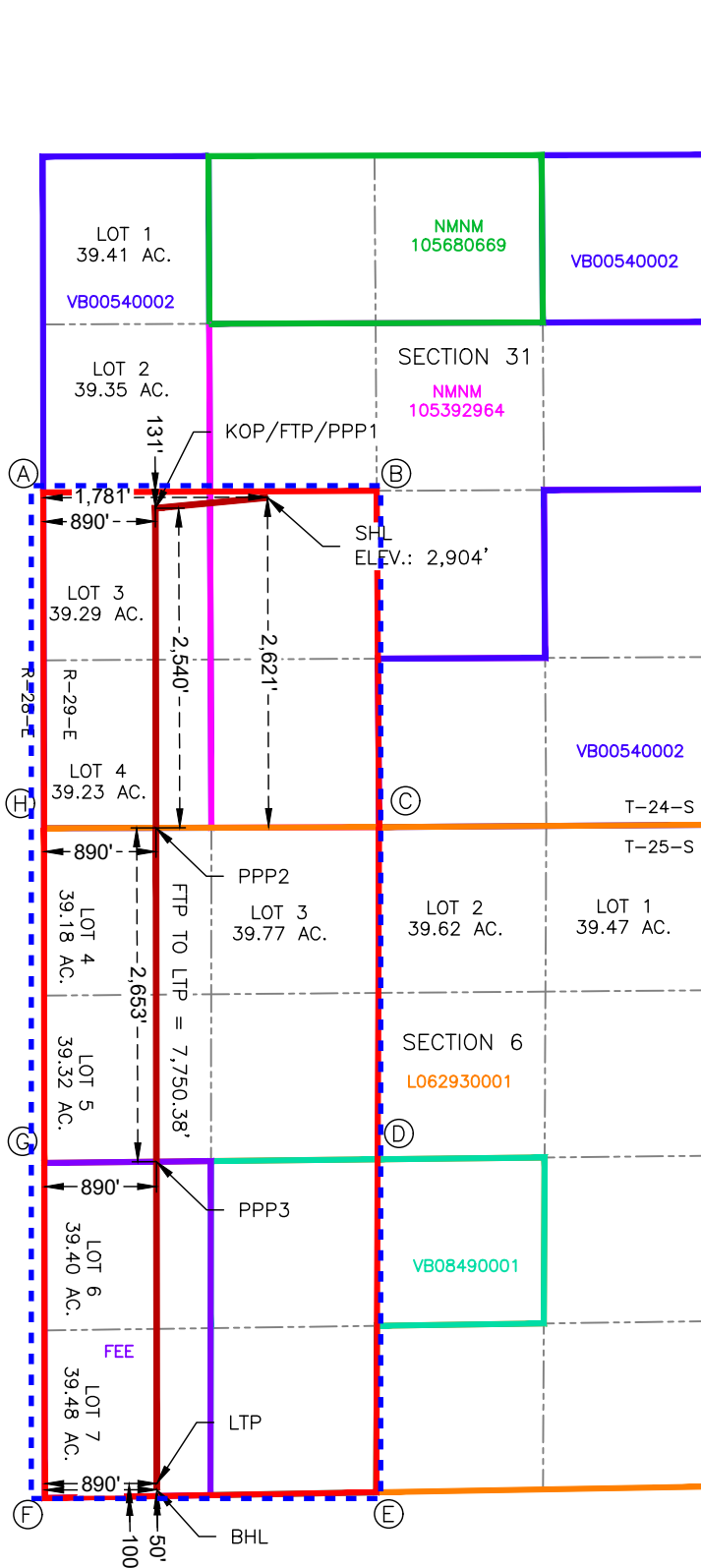

SURFACE HOLE LOCATION
 2,621' FSL & 1,781' FWL
 ELEV. = 2,904'
 NAD 83 X = 636,276.32'
 NAD 83 Y = 427,056.59'
 NAD 83 LAT = 32.173684°
 NAD 83 LONG = -104.026488°

KICK-OFF POINT,
 FIRST TAKE POINT &
 PENETRATION POINT 1
 2,540' FSL & 890' FWL
 NAD 83 X = 635,385.21'
 NAD 83 Y = 426,971.69'
 NAD 83 LAT = 32.173458°
 NAD 83 LONG = -104.029369°

PENETRATION POINT 2
 0' FSL & 890' FWL
 NAD 83 X = 635,390.86'
 NAD 83 Y = 424,431.70'
 NAD 83 LAT = 32.166476°
 NAD 83 LONG = -104.029374°

PENETRATION POINT 3
 2,653' FNL & 890' FWL
 NAD 83 X = 635,393.82'
 NAD 83 Y = 421,778.66'
 NAD 83 LAT = 32.159183°
 NAD 83 LONG = -104.029388°

LAST TAKE POINT
 100' FSL & 890' FWL
 NAD 83 X = 635,396.68'
 NAD 83 Y = 419,221.33'
 NAD 83 LAT = 32.152153°
 NAD 83 LONG = -104.029403°

BOTTOM HOLE LOCATION
 50' FSL & 890' FWL
 NAD 83 X = 635,396.74'
 NAD 83 Y = 419,171.32'
 NAD 83 LAT = 32.152015°
 NAD 83 LONG = -104.029403°

CORNER COORDINATES NEW MEXICO EAST - NAD 83	
POINT	NORTHING/EASTING
A	N:427,097.80' E:634,494.93'
B	N:427,110.00' E:637,144.11'
C	N:424,437.85' E:637,162.88'
D	N:421,797.68' E:637,151.46'
E	N:419,151.27' E:637,140.02'
F	N:419,106.02' E:634,506.81'
G	N:421,769.03' E:634,503.74'
H	N:424,428.61' E:634,500.87'

SWEET TEA STATE COM #552H



API BTC

Coupling	Pipe Body
Grade: J55 (Casing)	Grade: J55 (Casing)
Body: Bright Green	1st Band: Bright Green
1st Band: White	2nd Band: -
2nd Band: -	3rd Band: -
3rd Band: -	4th Band: -

Outside Diameter	10.750 in.	Wall Thickness	0.400 in.	Grade	J55 (Casing)
Min. Wall Thickness	87.50 %	Pipe Body Drift	API Standard	Type	Casing
Connection OD Option	Regular				

Pipe Body Data

Geometry		Performance	
Nominal OD	10.750 in.	Drift	9.794 in.
Wall Thickness	0.400 in.	Plain End Weight	44.26 lb/ft
Nominal Weight	45.500 lb/ft	OD Tolerance	API
Nominal ID	9.950 in.		
		SMYS	55,000 psi
		Min UTS	75,000 psi
		Body Yield Strength	715 x1000 lb
		Min. Internal Yield Pressure	3580 psi
		Collapse Pressure	2090 psi
		Max. Allowed Bending	23 °/100 ft

Connection Data

Geometry		Performance	
Thread per In	5	Joint Strength	796 x1000 lb
Connection OD	11.750 in.	Coupling Face Load	628 x1000 lb
Hand Tight Stand Off	1 in.	Internal Pressure Capacity	3580 psi

Notes

For products according to API Standards 5CT & 5B; Performance calculated considering API Technical Report 5C3 (Sections 9 & 10) equations. For geometrical and steel grades combinations not considered in the API Standards 5CT and/or 5B; Performance calculations indirectly derived from API Technical Report 5C3 (Sections 9 & 10) equations. Couplings OD are shown according to current API 5CT 10th Edition.

Tenaris has issued this document for general information only, and the information in this document, including, without limitation, any pictures, drawings or designs ("Information") is not intended to constitute professional or any other type of advice or recommendation and is provided on an "as is" basis. No warranty is given. Tenaris has not independently verified any information—if any—provided by the user in connection with, or for the purpose of, the Information contained hereunder. The use of the Information is at user's own risk and Tenaris does not assume any responsibility or liability of any kind for any loss, damage or injury resulting from, or in connection with any Information contained hereunder or any use thereof. The Information in this document is subject to change or modification without notice. Tenaris's products and services are subject to Tenaris's standard terms and conditions or otherwise to the terms resulting from the respective contracts of sale or services, as the case may be, between petitioner and Tenaris. For more complete information please contact a Tenaris's representative or visit our website at www.tenaris.com. ©Tenaris 2022. All rights reserved.



API BTC

Coupling	Pipe Body
Grade: L80-ICY	Grade: L80-ICY
Body: Red	1st Band: Red
1st Band: Brown	2nd Band: Brown
2nd Band: Pale Green	3rd Band: Pale Green
3rd Band: -	4th Band: Pale Green

Outside Diameter	7.625 in.	Wall Thickness	0.375 in.	Grade	L80-ICY
Min. Wall Thickness	87.50 %	Pipe Body Drift	API Standard	Type	Casing
Connection OD Option	Regular				

Pipe Body Data

Geometry				Performance	
Nominal OD	7.625 in.	Drift	6.750 in.	SMYS	85,000 psi
Wall Thickness	0.375 in.	Plain End Weight	29.06 lb/ft	Min UTS	95,000 psi
Nominal Weight	29.700 lb/ft	OD Tolerance	API	Body Yield Strength	726 x1000 lb
Nominal ID	6.875 in.			Min. Internal Yield Pressure	7320 psi
				Collapse Pressure	5900 psi
				Max. Allowed Bending	51 °/100 ft

Connection Data

Geometry		Performance	
Thread per In	5	Joint Strength	733 x1000 lb
Connection OD	8.500 in.	Coupling Face Load	597 x1000 lb
Hand Tight Stand Off	1 in.	Internal Pressure Capacity	7320 psi

Notes

For products according to API Standards 5CT & 5B; Performance calculated considering API Technical Report 5C3 (Sections 9 & 10) equations. For geometrical and steel grades combinations not considered in the API Standards 5CT and/or 5B; Performance calculations indirectly derived from API Technical Report 5C3 (Sections 9 & 10) equations. Couplings OD are shown according to current API 5CT 10th Edition.

Tenaris has issued this document for general information only, and the information in this document, including, without limitation, any pictures, drawings or designs ("Information") is not intended to constitute professional or any other type of advice or recommendation and is provided on an "as is" basis. No warranty is given. Tenaris has not independently verified any information—if any—provided by the user in connection with, or for the purpose of, the Information contained hereunder. The use of the Information is at user's own risk and Tenaris does not assume any responsibility or liability of any kind for any loss, damage or injury resulting from, or in connection with any Information contained hereunder or any use thereof. The Information in this document is subject to change or modification without notice. Tenaris's products and services are subject to Tenaris's standard terms and conditions or otherwise to the terms resulting from the respective contracts of sale or services, as the case may be, between petitioner and Tenaris. For more complete information please contact a Tenaris's representative or visit our website at www.tenaris.com. ©Tenaris 2024. All rights reserved.

BOPE Break Testing Variance

Initial and 21 Day Testing of 10K BOP's:

Component	High Test Pressure	Low Test Pressure	Duration
Annular Preventer	5,000 psig	250 psig	10 min
Rams	5,000 psig	250 psig	10 min
Manifold	5,000 psig	250 psig	10 min
Wellhead	1,500 psig	-	10 min
Upper / Lower / Kelly Valves	5,000 psig	250 psig	10 min
TIW safety valves / Dart	5,000 psig	250 psig	10 min
Standpipe and mud line to pumps	5,000 psig	250 psig	10 min
Surface Casing (with 8.4 ppg fluid)	1,500 psig	-	30 min

*Equipment satisfies 10M BOPE but break test variance applies to 5M system

COG Production LLC formally requests variance from the minimum standards for well control equipment testing of Onshore Order No. 2 (item III.A.2.a.i) to allow break/shell testing of blowout preventor (BOP) and blowout prevention equipment (BOPE) during batch drilling operations of the intermediate hole section. This variance only applies to 5M BOPE or less formation.

Initial testing of the BOP will be conducted, verifying all components of BOP, BOPE, and choke manifold meet the minimum and maximum anticipated surface pressure (MASP) in accordance with API RP 53 and Onshore Order No. 2, reference table above. Once initial test pressures are achieved, shell testing of the BOP and choke manifold would be conducted within the time limit from initial test to the congruent 21-day test. A complete pressure test of the BOPE components will be completed no later than 21 days following the completion of the initial pressure test or latest complete BOP pressure test date succeeding the initial test, per API RP 53 (6.5.3.4.1 (d)).

BOP and BOPE Testing

- Minimum of Class 3 stack arrangement with one set of blind/blind shear rams and pipe rams shall be installed for a 5K pressure rated system per API RP 53 (6.1.2.9)
 - Classification - COP minimum of Class 3 arrangement apply for all Delaware Basin area wells.
 - Arrangement - Annular preventer, upper pipe rams, blind rams, mud cross, lower pipe rams
- Complete BOP and BOPE test performed at initial installation on well pad.
 - Initial test performed on well with deepest planned intermediate hole section (allowable 200' TVD variance between intermediate hole sections)
 - Annular preventer tested to 100 percent of MASP, or 70 percent of rated working pressure (RWP), whichever is greater.
 - Notify BLM 4 Hrs. prior to testing
- Complete BOP and BOPE test every 21 days in accordance with API RP 53 (6.5.3.4.1 (d)).
- BOP/BOPE shell test (inclusive of manifold shell test) performed during batch drilling operations during rig transition between wells (within the 21-day time limit per API RP 53).
- Function test BOP elements per API RP 53 (6.5.3.1).
 - Required on (1) initial installation of stack, (2) every 7 days, (3) after repair/replacement of any control components
 - Alternate between drillers panel and remote panel

Securing the Wellhead

- Prior to moving rig off check for flow
 - Ensure floats are holding, casing is full of kill mud and backside is static.
- Secure the well with sleeve/plug with BPV
- Disconnect BOP from the wellhead and walk with the rig to another well on the pad.
 - Utilizing BOP wrangler/cradle, maintaining control and upright position of the BOP during movement
- Once BOP is separated from wellhead the Temporary Abandonment (TA) cap will be installed per Wellhead vendor procedure and pressure inside the casing will be monitored via the valve on the TA cap as per standard batch drilling ops.
- Test TA cap to 5,000 psi for 10 min.

COG Production LLC believes that the combination of drilling fluid inside the casing, abandonment plug with BPV, casing and annular valves and the TA cap provide multiple barriers to ensure complete closure of the wellbore prior to skidding/walking the rig.

Break Testing

- Skid rig over the next well on pad and center over wellhead, N/U BOP with the use of the BOP quick connect.
- Shell test the BOP and choke manifold to 5,000 psig and 250 psig. Hold each test for 10 minutes.
 - In accordance with API RP 53 (6.5.3.4.1(b)) BOP shell test will satisfy pressure test of quick connect seals
 - Notify BLM 4 hours prior to testing
- RWP of BOP quick connect is 10K (Certificate of Conformance attached)

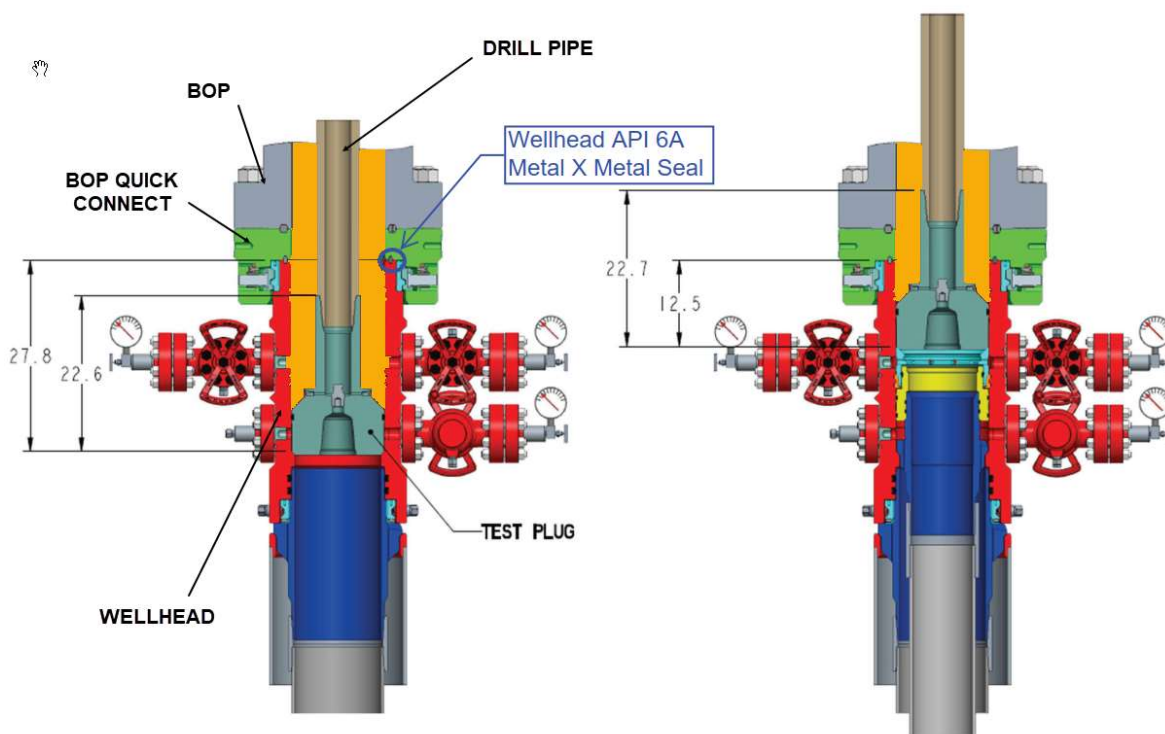

Figure 1: Test plug installed (The orange sections above indicate the areas exposed to the pressure test)

Example Well Control Plan Content

A. Well Control Component Table

This table, combined with the mud program, documents that two barriers to flow can be maintained at all times, independent of the BOP nipped up to the wellhead.

Intermediate hole section, 5M requirement

Component	RWP
Pack-off	10M
Casing Wellhead Valves	10M
Annular Wellhead Valves	5M
TA Plug	10M
Float Valves	5M
2" 1502 Lo-Torque Valves	10M

B. Well Control Procedures

Well control procedures are specific to the rig equipment and the operation at the time the kick occurs. Below are the minimal high-level tasks prescribed to assure a proper shut-in while circulating.

General Procedure

1. Sound alarm (alert crew).
2. Shut down pumps.
3. Shut-in Well (close valves to rig pits and open valve to rig choke line. Rig choke will already be in the closed position).
4. Confirm shut in.
5. Notify tool pusher/company representative.
6. Read and record the following:
 - a. SICP (Shut in Casing Pressure) and AP (Annular Pressure)
 - b. Pit gain
 - c. Time
 - d. Regroup and identify forward plan to continue circulating out kick via rig choke and mud/gas separator. Circulate and adjust mud density as needed to control well.

Form 3160-5
(October 2024)

UNITED STATES
DEPARTMENT OF THE INTERIOR
BUREAU OF LAND MANAGEMENT

FORM APPROVED
OMB No. 1004-0220
Expires: October 31, 2027

SUNDRY NOTICES AND REPORTS ON WELLS
Do not use this form for proposals to drill or to re-enter an abandoned well. Use Form 3160-3 (APD) for such proposals.

5. Lease Serial No.	NMNM111533
6. If Indian, Allottee or Tribe Name	

SUBMIT IN TRIPLICATE - Other instructions on page 2		7. If Unit of CA/Agreement, Name and/or No.
1. Type of Well <input checked="" type="checkbox"/> Oil Well <input type="checkbox"/> Gas Well <input type="checkbox"/> Other	8. Well Name and No. SWEET TEA EBS FEDERAL COM/552H	
2. Name of Operator MARATHON OIL PERMIAN LLC	9. API Well No. 3001555630	
3a. Address 990 TOWN & COUNTRY BLVD, HOUSTON, TX	3b. Phone No. (include area code) (713) 296-2113	10. Field and Pool or Exploratory Area WILLOW LAKE/BONE SPRING
4. Location of Well (Footage, Sec., T.,R.,M., or Survey Description) SEC 31/T24S/R29E/1PM		11. Country or Parish, State EDDY/NM

12. CHECK THE APPROPRIATE BOX(ES) TO INDICATE NATURE OF NOTICE, REPORT OR OTHER DATA

TYPE OF SUBMISSION	TYPE OF ACTION			
<input checked="" type="checkbox"/> Notice of Intent	<input type="checkbox"/> Acidize	<input type="checkbox"/> Deepen	<input type="checkbox"/> Production (Start/Resume)	<input type="checkbox"/> Water Shut-Off
<input type="checkbox"/> Subsequent Report	<input type="checkbox"/> Alter Casing	<input type="checkbox"/> Hydraulic Fracturing	<input type="checkbox"/> Reclamation	<input type="checkbox"/> Well Integrity
<input type="checkbox"/> Final Abandonment Notice	<input type="checkbox"/> Casing Repair	<input type="checkbox"/> New Construction	<input type="checkbox"/> Recomplete	<input type="checkbox"/> Other
	<input checked="" type="checkbox"/> Change Plans	<input type="checkbox"/> Plug and Abandon	<input type="checkbox"/> Temporarily Abandon	
	<input type="checkbox"/> Convert to Injection	<input type="checkbox"/> Plug Back	<input type="checkbox"/> Water Disposal	

13. Describe Proposed or Completed Operation: Clearly state all pertinent details, including estimated starting date of any proposed work and approximate duration thereof. If the proposal is to deepen directionally or recomplete horizontally, give subsurface locations and measured and true vertical depths of all pertinent markers and zones. Attach the Bond under which the work will be performed or provide the Bond No. on file with BLM/BIA. Required subsequent reports must be filed within 30 days following completion of the involved operations. If the operation results in a multiple completion or recompletion in a new interval, a Form 3160-4 must be filed once testing has been completed. Final Abandonment Notices must be filed only after all requirements, including reclamation, have been completed and the operator has determined that the site is ready for final inspection.)

MARATHON OIL PERMIAN LLC, respectfully requests approval for the following changes to the original approved APD.

APD ID: 10400095883
API #30-015-55630

Summary of Changes:

No changes in targets
MD at TD changed to 16,508'
TVD of target changed to 8,834'

BHL CHANGES: From: 100' FSL & 990' FWL Section 6. T25S. R29E.

Continued on page 3 additional information

14. I hereby certify that the foregoing is true and correct. Name (Printed/Typed) MAYTE REYES / Ph: (281) 293-1000	Regulatory Analyst Title
Signature (Electronic Submission)	Date 02/13/2026

THE SPACE FOR FEDERAL OR STATE OFFICE USE

Approved by CHRISTOPHER WALLS / Ph: (575) 234-2234 / Approved	Petroleum Engineer Title	02/20/2026 Date
Conditions of approval, if any, are attached. Approval of this notice does not warrant or certify that the applicant holds legal or equitable title to those rights in the subject lease which would entitle the applicant to conduct operations thereon.	Office CARLSBAD	

Title 18 U.S.C Section 1001 and Title 43 U.S.C Section 1212, make it a crime for any person knowingly and willfully to make to any department or agency of the United States any false, fictitious or fraudulent statements or representations as to any matter within its jurisdiction.

(Instructions on page 2)

GENERAL INSTRUCTIONS

This form is designed for submitting proposals to perform certain well operations and reports of such operations when completed as indicated on Federal and Indian lands pursuant to applicable Federal law and regulations. Any necessary special instructions concerning the use of this form and the number of copies to be submitted, particularly with regard to local area or regional procedures and practices, are either shown below, will be issued by or may be obtained from the local Federal office.

SPECIFIC INSTRUCTIONS

Item 4 - Locations on Federal or Indian land should be described in accordance with Federal requirements. Consult the local Federal office for specific instructions.

Item 13: Proposals to abandon a well and subsequent reports of abandonment should include such special information as is required by the local Federal office. In addition, such proposals and reports should include reasons for the abandonment; data on any former or present productive zones or other zones with present significant fluid contents not sealed off by cement or otherwise; depths (top and bottom) and method of placement of cement plugs; mud or other material placed below, between and above plugs; amount, size, method of parting of any casing, liner or tubing pulled and the depth to the top of any tubing left in the hole; method of closing top of well and date well site conditioned for final inspection looking for approval of the abandonment. If the proposal will involve **hydraulic fracturing operations**, you must comply with 43 CFR 3162.3-3, including providing information about the protection of usable water. Operators should provide the best available information about all formations containing water and their depths. This information could include data and interpretation of resistivity logs run on nearby wells. Information may also be obtained from state or tribal regulatory agencies and from local BLM offices.

NOTICES

The privacy Act of 1974 and the regulation in 43 CFR 2.48(d) provide that you be furnished the following information in connection with information required by this application.

AUTHORITY: 30 U.S.C. 181 et seq., 351 et seq., 25 U.S.C. 396; 43 CFR 3160.

PRINCIPAL PURPOSE: The information is used to: (1) Evaluate, when appropriate, approve applications, and report completion of subsequent well operations, on a Federal or Indian lease; and (2) document for administrative use, information for the management, disposal and use of National Resource lands and resources, such as: (a) evaluating the equipment and procedures to be used during a proposed subsequent well operation and reviewing the completed well operations for compliance with the approved plan; (b) requesting and granting approval to perform those actions covered by 43 CFR 3162.3-2, 3162.3-3, and 3162.3-4; (c) reporting the beginning or resumption of production, as required by 43 CFR 3162.4-1(c) and (d) analyzing future applications to drill or modify operations in light of data obtained and methods used.

ROUTINE USES: Information from the record and/or the record will be transferred to appropriate Federal, State, local or foreign agencies, when relevant to civil, criminal or regulatory investigations or prosecutions in connection with congressional inquiries or to consumer reporting agencies to facilitate collection of debts owed the Government.

EFFECT OF NOT PROVIDING THE INFORMATION: Filing of this notice and report and disclosure of the information is mandatory for those subsequent well operations specified in 43 CFR 3162.3-2, 3162.3-3, 3162.3-4.

The Paperwork Reduction Act of 1995 requires us to inform you that:

The BLM collects this information to evaluate proposed and/or completed subsequent well operations on Federal or Indian oil and gas leases.

Response to this request is mandatory.

The BLM would like you to know that you do not have to respond to this or any other Federal agency-sponsored information collection unless it displays a currently valid OMB control number.

BURDEN HOURS STATEMENT: Public reporting burden for this form is estimated to average 8 hours per response, including the time for reviewing instructions, gathering and maintaining data, and completing and reviewing the form. Direct comments regarding the burden estimate or any other aspect of this form to U.S. Department of the Interior, Bureau of Land Management (1004-0137), Bureau Information Collection Clearance Officer (WO-630), 1849 C St., N.W., Mail Stop 401 LS, Washington, D.C. 20240

Additional Information

Additional Remarks

To: 50' FSL & 890' FWL Section 6. T25S. R29E.

C102 Attached.

NAME CHANGE:

From: SWEET TEA EBS FEDERAL COM 552H

To: SWEET TEA STATE COM 552H

C102 Attached.

DRILLING CHANGES:

Drilling program,

Directional Plan, AC Report, Bradenhead, Break Testing and Specs attached.

Location of Well

0. SHL: NESW / 2622 FSL / 1781 FWL / TWSP: 24S / RANGE: 29E / SECTION: 31 / LAT: 32.1736843 / LONG: -104.0264881 (TVD: 0 feet, MD: 0 feet)

PPP: NWSW / 2540 FSL / 990 FWL / TWSP: 24S / RANGE: 29E / SECTION: 31 / LAT: 32.1734581 / LONG: -104.0290457 (TVD: 9130 feet, MD: 9700 feet)

BHL: LOT 7 / 100 FSL / 990 FWL / TWSP: 25S / RANGE: 29E / SECTION: 6 / LAT: 32.1521571 / LONG: -104.0290794 (TVD: 9130 feet, MD: 16729 feet)

CONFIDENTIAL

ConocoPhillips Company - SWEET TEA FEDERAL COM 552H

1. Geologic Formations

TVD of target	8,834' EOL	Pilot hole depth	NA
MD at TD:	16,508'	Deepest expected fresh water:	0'

Formation	Depth (TVD) from KB	Water/Mineral Bearing/ Target Zone?	Hazards*
Quaternary Fill	Surface	Water	
Rustler	372	Water	
Top of Salt	1117	Salt	
Base of Salt	2529	Salt	
Lamar	2726	Salt Water	
Bell Canyon	2756	Salt Water	
Cherry Canyon	3619	Oil/Gas	
Brushy Canyon	4866	Oil/Gas	
Bone Spring	6422	Oil/Gas	
1st Bone Spring Sand	7374	Oil/Gas	
2nd Bone Spring Sand	8171	Oil/Gas	
3rd Bone Spring Carb	8531	Target	

2. Casing Program

Hole Size	Casing Interval		Csg. Size	Weight (lbs)	Grade	Conn.	SF Collapse	SF Burst	SF Body	SF Joint
	From	To								
14.75"	0	970	10.75"	45.5	J55	BTC	4.71	1.14	16.20	18.04
9.875"	0	7500	7.625"	29.7	L80-ICY	BTC	1.51	1.38	3.26	3.29
8.750"	7500	8300	7.625"	29.7	P110-ICY	W513	1.71	2.08	4.33	2.60
6.75"	0	8100	5.5"	23	P110-CY	BTC	2.56	2.98	3.91	3.91
6.75"	8100	16,508	5.5"	23	P110-CY	W441	2.34	2.73	3.59	3.26
BLM Minimum Safety Factor							1.125	1	1.6 Dry 1.8 Wet	1.6 Dry 1.8 Wet

2b. Contingency Casing Program

Hole Size	Casing Interval		Csg. Size	Weight (lbs)	Grade	Conn.	SF Collapse	SF Burst	SF Body	SF Joint
	From	To								
17.50"	0	970	13.375"	54.5	J55	BTC	2.55	2.47	16.14	17.19
12.25"	0	2630	9.625"	40	L80-IC	BTC	2.83	1.77	8.71	9.00
8.75"	2430	8300	7.625"	29.7	P110-ICY	W513	1.71	2.08	4.33	2.60
6.75"	0	8100	5.5"	23	P110-CY	BTC	2.56	2.98	3.91	3.91
6.75"	8100	16,508	5.5"	23	P110-CY	W441	2.34	2.73	3.59	3.26
BLM Minimum Safety Factor							1.125	1	1.6 Dry 1.8 Wet	1.6 Dry 1.8 Wet

Intermediate casing will be kept at least 1/3 full while running casing to mitigate collapse. Surface burst based on 0.7 frac gradient at the shoe with Gas Gradient 0.1 psi/ft to surface and

All casing strings will be tested in accordance with 43 CFR Part 3170 Subpart 3172

Contingency program will be run if large water flows are encountered.

The 5 1/2" W441 casing will be run back 200' into the intermediate casing to ensure the coupling OD clearance is greater than .422" for the cement bond tie in.

ConocoPhillips Company - SWEET TEA FEDERAL COM 552H

	Y or N
Is casing new? If used, attach certification as required in Onshore Order #1	Y
Does casing meet API specifications? If no, attach casing specification sheet.	Y
Is premium or uncommon casing planned? If yes attach casing specification sheet.	Y
Does the above casing design meet or exceed BLM's minimum standards? If not provide justification (loading assumptions, casing design criteria).	Y
Will the intermediate pipe be kept at a minimum 1/3 fluid filled to avoid approaching the collapse pressure rating of the casing?	Y
Is well located within Capitan Reef? If yes, does production casing cement tie back a minimum of 50' above the Reef? Is well within the designated 4 string boundary?	N
Is well located in SOPA but not in R-111-P? If yes, are the first 2 strings cemented to surface and 3 rd string cement tied back 500' into previous casing?	N
Is well located in R-111-P and SOPA? If yes, are the first three strings cemented to surface? Is 2 nd string set 100' to 600' below the base of salt?	N
Is well located in high Cave/Karst? If yes, are there two strings cemented to surface? (For 2 string wells) If yes, is there a contingency casing if lost circulation occurs?	N
Is well located in critical Cave/Karst? If yes, are there three strings cemented to surface?	N

ConocoPhillips Company - SWEET TEA FEDERAL COM 552H

3. Cementing Program

Casing	# Sks	Wt. lb/ gal	Yld ft3/ sack	H ₂ O gal/sk	500# Comp. Strength (hours)	Slurry Description
Surf.	470	12.8	1.75	9	12	Lead: Class C + 4% Gel + 1% CaCl ₂
	250	14.8	1.34	6.34	8	Tail: Class C + 2% CaCl ₂
Inter. Stage 1	650	10.3	3.3	22	24	Halliburton tuned light
	250	14.8	1.35	6.6	8	Tail: Class H
Prod	510	12.5	1.48	10.7	72	Lead: 50:50:10 H Blend
	630	13.2	1.34	5.7	19	Tail: 50:50:2 Class H Blend

If losses are encountered in the intermediate section a DV/ECP tool will be run ~50' above the Lamar Lime top, cement will be adjusted accordingly if this contingency is necessary.

Volumes Subject to Observed Hole Conditions and/or Fluid Caliper Results

Lab reports with the 500 psi compressive strength time for the cement will be onsite for review.

Casing String	TOC	% Excess
Surface	0'	50%
1 st Intermediate	0'	50%
Production	7,800'	20% OH in Lateral (KOP to EOL)

3b. Contingency Cementing Program

Casing	# Sks	Wt. lb/ gal	Yld ft3/ sack	H ₂ O gal/sk	500# Comp. Strength (hours)	Slurry Description
Surf.	580	13.5	1.75	9	12	Lead: Class C + 4% Gel + 1% CaCl ₂
	250	14.8	1.34	6.34	8	Tail: Class C + 2% CaCl ₂
Int. #1	330	12.8	1.75	9.21	12	Lead: Class C + 4% Gel + 1% CaCl ₂
	390	14.8	1.35	6.6	8	Tail: Class C + 2% CaCl ₂
Inter. #2 (Liner)	200	10.5	3.3	22	24	Tuned light
	90	14.8	1.35	6.6	8	Tail: Class H
Prod	500	12.5	1.48	10.7	72	Lead: 50:50:10 H Blend
	630	13.2	1.34	5.7	19	Tail: 50:50:2 Class H Blend

Contingency program will be run if large water flows are encountered.

Casing String	TOC	% Excess
Surface	0'	50%
1 st Intermediate	0'	50%
2 nd Intermediate	2,430'	20%
Production	8,050'	20% OH in Lateral (KOP to EOL)

If conditions dictate, an offline bradenhead cement job will be performed to ensure cement to surface. A CBL will be ran Offline to verify TOC after 2nd Stage Bradenhead.

ConocoPhillips Company - SWEET TEA FEDERAL COM 552H

4. Pressure Control Equipment

N	A variance is requested for the use of a diverter on the surface casing. See attached for schematic.
Y	A variance is requested for the use of BOPE break testing on intermediate skirts (in accordance with the 30 day full BOPE test requirements).

BOP installed and tested before drilling which hole?	Size?	Min. Required WP	Type	x	Tested to:
12-1/4" or 9-7/8"	13-5/8"	5M	Annular	x	2500psi
			Blind Ram	x	
			Pipe Ram	x	5000psi
			Double Ram	x	
			Other*		
6-3/4"	13-5/8"	10M	5M Annular	x	5000psi
			Blind Ram	x	
			Pipe Ram	x	10000psi
			Double Ram	x	
			Other*		

BOP/BOPE will be tested by an independent service company to 250 psi low and the high pressure indicated above per 43 CFR Part 3170 Subpart 3172 requirements. The System may be upgraded to a higher pressure but still tested to the working pressure listed in the table above. If the system is upgraded all the components installed will be functional and tested.

Pipe rams will be operationally checked each 24 hour period. Blind rams will be operationally checked on each trip out of the hole. These checks will be noted on the daily tour sheets. Other accessories to the BOP equipment will include a Kelly cock and floor safety valve (inside BOP) and choke lines and choke manifold. See attached schematics.

Y	Formation integrity test will be performed per Onshore Order #2.
Y	On Exploratory wells or on that portion of any well approved for a 5M BOPE system or greater, a pressure integrity test of each casing shoe shall be performed. Will be tested in accordance with 43 CFR Part 3170 Subpart 3172.
Y	A variance is requested for the use of a flexible choke line from the BOP to Choke Manifold. See attached for specs and hydrostatic test chart.
N	Are anchors required by manufacturer?
Y	A multibowl wellhead is being used. The BOP will be tested per 43 CFR Part 3170 Subpart 3172 after installation on the surface casing which will cover testing requirements for a maximum of 30 days. If any seal subject to test pressure is broken the system must be tested.

ConocoPhillips Company - SWEET TEA FEDERAL COM 552H

5. Mud Program

Depth		Type	Weight (ppg)	Viscosity	Water Loss
From	To				
0	Surf. Shoe	FW Gel	8.6 - 8.8	28-34	N/C
Surf csg	7-5/8" Int shoe	Brine Diesel Emulsion	8.4 - 10	28-34	N/C
7-5/8" Int shoe	Lateral TD	WBM	9.5-10.5	28-34	N/C

Sufficient mud materials to maintain mud properties and meet minimum lost circulation and weight increase requirements will be kept on location at all times.

What will be used to monitor the loss or gain of fluid?	PVT/Pason/Visual Monitoring
---	-----------------------------

5b. Contingency Mud Program

Depth		Type	Weight (ppg)	Viscosity	Water Loss
From	To				
0	Surf. Shoe	FW Gel	8.6 - 8.8	28-34	N/C
Surf csg	9-5/8" Int shoe	Brine	8.4 - 10	28-34	N/C
9-5/8" Int shoe	7-5/8" Int shoe	Brine	8.4 - 10	28-34	N/C
7-5/8" Int shoe	Lateral TD	OBM	9.6 - 13.5	35-45	<20

6. Logging and Testing Procedures

Logging, Coring and Testing.	
Y	Will run GR/CNL from TD to surface (horizontal well – vertical portion of hole). Stated logs run will be in the Completion Report and submitted to the BLM.
Y	No Logs are planned based on well control or offset log information.
N	Drill stem test? If yes, explain.
N	Coring? If yes, explain.

Additional logs planned	Interval
N Resistivity	Pilot Hole TD to ICP
N Density	Pilot Hole TD to ICP
Y CBL	Production casing (If cement not circulated to surface)
Y Mud log	Intermediate shoe to TD
N PEX	

ConocoPhillips Company - SWEET TEA FEDERAL COM 552H

7. Drilling Conditions

Condition	Specify what type and where?
BH Pressure at deepest TVD	6205 psi at 8834' TVD
Abnormal Temperature	NO 145 Deg. F.

No abnormal pressure or temperature conditions are anticipated. Sufficient mud materials to maintain mud properties and weight increase requirements will be kept on location at all times.

Sufficient supplies of Paper/LCM for periodic sweeps to control seepage and losses will be maintained on location.

Hydrogen Sulfide (H2S) monitors will be installed prior to drilling out the surface shoe. If H2S is detected in concentrations greater than 100 ppm, the operator will comply with the provisions of 43 CFR Part 3170 Subpart 3176. If Hydrogen Sulfide is encountered, measured values and formations will be provided to the BLM.	
N	H2S is present
Y	H2S Plan attached

8. Other Facets of Operation

Y	Is it a walking operation?
Y	Is casing pre-set?
Y	Is it a batch drilling operation?

x	H2S Plan.
x	BOP & Choke Schematics.
x	Directional Plan

Offline Bradenhead Cementing Procedure

1. Run casing as per normal operations.
 - a. Float equipment is equipped with two back pressure valves rated to a minimum of 5,000 psi.
2. Land intermediate casing on mandrel hanger through BOP.
 - a. If casing is unable to be landed with a mandrel hanger, then the **casing will be cemented online**.
 - b. If time from landing mandrel hanger to skidding/walking rig off well exceeds 8 hours, BLM will be notified.
3. Break circulation and confirm no restrictions.
 - a. Ensure no blockage of float equipment and appropriate annular returns.
4. Perform flow check to confirm well is static.
5. Install pack-off.
 - a. If utilizing a fluted/ported mandrel hanger, ensure well is static on the annulus and inside the casing by ensuring pipe is full of drilling fluid, remove landing joint, and install annular packoff through BOP. Pressure test to 5,000 psi for 10 min (or as per wellhead company recommendation).
 - b. If utilizing a solid mandrel hanger, ensure well is static on the annulus and inside the casing by ensuring pipe is full of drilling fluid. Pressure test seals to 5,000 psi for 10 min (or as per wellhead company recommendation). Remove landing joint through BOP.
6. After confirmation of both annular barriers and the two casing barriers, install offline cement plug and pressure test to 5,000 psi for 10 min (or as per wellhead company recommendation).
 - a. Follow Stream-Flo running procedure for setting and testing the offline cement plug.
7. Notify the BLM with intent to proceed with nipple down and offline cementing. Minimum 4 hrs notice.
8. With the well secured and BLM notified, nipple down BOP and secure on BOP handler.
 - a. **Note, if any of the barriers fail to test, the BOP stack will not be nipped down until after the cement job has concluded and tail cement has reached 500 psi**
9. Skid/Walk rig off current well.
10. Install TA cap with seal sleeve and test to 5,000 psi.
11. Rig up return lines to take returns from wellhead to pits via offline cement choke manifold.
 - a. Test all connections and lines from wellhead to choke manifold to 5,000 psi high for 10 min.
 - b. If either test fails, perform corrections and retest before proceeding.
 - c. Return line schematics can be seen in Figure 2.
12. Confirm well is static before removing TA Plug.
 - a. Cementing operations will not proceed until well is under control. (If well is not static, notify BLM and proceed to kill)
 - b. Casing outlet valves will provide access to both the casing ID and annulus. Rig or third-party pump truck will kill well prior to cementing, if needed.
 - c. Well control plan can be seen in Section B, Well Control Procedures.
 - d. If need be, rig can be moved back over well and BOP nipped back up for any further remediation.
13. Remove TA Plug/BPV from the casing.
14. Install offline cement tool.
 - a. Current offline cement tool schematics can be seen in Figure 1 (Streamflo)
15. Rig up cement head and cementing lines.
 - a. Pressure test cement lines against cement head to 80% of casing burst for 10 min.
16. Break circulation on well to confirm no restrictions.
 - a. If gas is present on circulation, well will be shut in and returns rerouted through gas buster.
 - b. Max anticipated time before circulating with cement truck is 6 hrs.
17. Circulate 1.5 times casing capacity.
 - a. Pump a minimum of 375 bbls brine water ahead of spacer to ensure all drilling fluid is circulated out of the annulus.
 - b. If have no returns, pump a minimum of 1 x Bottoms Up of brine from shoe to top of brushy canyon.
 - c. Pump 25 bbls spacer followed by 620 sacks of 15.6 ppg cement designed to reach the top of the Brushy Canyon.
 - d. Catch wet and dry samples of slurry.
 - e. Drop wiper plug

Offline Bradenhead Cementing Procedure

- f. Displace with Brine. Do not over displace.
 - g. Bump plug at 500 psi over FCP and hold for 5 minutes.
 - h. Bleed back to cement truck to check floats.
18. Confirm well is static and floats are holding after cement job.
- a. If floats are leaking:
 - i. Shut-in well and WOC (Wait on Cement) until tail slurry reaches 500 psi compressive strength and the casing is static prior to removing cement head.
 - ii. In case of a float failure, run a retrievable bridge plug at 1000 ft above KOP, test same
 - b. If there is flow on the backside:
 - i. Shut in well and WOC until tail slurry reaches 500 psi compressive strength. Ensure that the casing is static prior to removing cement head.
19. At plug bump, pressure test casing to FIT or 1,500 psi, whichever is greater.
- a. If plug does not bump, shut down and WOC 8 hrs or 500 psi compressive strength, whichever is greater before testing casing.
20. Remove cement head and install BPV.
21. Install TA cap. Pressure test to 5,000 psi for 10 min.
22. WOC for 4 hours from plug down time.
- a. While WOC, rig up lines to pump down both bottom SOVs on 10-3/4" x 7-5/8" annulus. Also, can rig up lines from SOV to just below top of cellar while drilling ahead to expedite rig-up later.
23. After 4 hours from plug down, establish injection rate and displace the annulus with 5 bbls fresh water.
- a. Max pressure is 1500 psi based on 10-3/4" surface casing pressure test.
24. Pump bradenhead squeeze utilizing 1000 sacks of 14.8 ppg thixotropic cement.
- a. Max pressure is 1500 psi
25. After pumping 14.8 ppg thixotropic slurry, pump 50 sacks of 14.8 ppg top out slurry to flush valves of thixotropic cement.
26. Shut in outlet valves as soon as pumps are confirmed off and WOC 4 hours.
27. Rig up to pump down 1 x SOV and take returns through other SOV into cellar.
28. Top out with 400 sacks of 14.8 ppg top out slurry. If more cement is necessary, note in report and notify BLM.
- a. Ensure 1 x empty vac truck with sugar on site prior to starting top out
 - b. Slowly pump cement (< 1 bpm) into the inlet SOV with valve open and increase rate up to max of 2 bpm until first air bubble is caught and cement starts coming out SOV. Drop rate to ½ - 1 bpm and pump until solid stream of cement observed at surface. Can drop rate at each air bubble as needed.
 - c. Once solid stream of cement observed at surface, shut down and wait 5 minutes.
 - d. Come back online at ½ bpm and ensure solid stream of cement.
29. Pump 2-5 bbls fresh water as needed to ensure all cement flushed out of wellhead valves.
- a. Note in report maximum number of bbls utilized
30. Shut down and close SOVs.

DELAWARE BASIN WEST

**ATLAS PROSPECT_NME
SWEET TEA FED COM PROJECT
_SWEET TEA FEDERAL COM 552H
300155563000
OWB**

Plan: PWP0

Standard Planning Report

11 February, 2026

ConocoPhillips Planning Report

Database:	EDT 17 Permian Prod	Local Co-ordinate Reference:	Well _SWEET TEA FEDERAL COM 552H
Company:	DELAWARE BASIN WEST	TVD Reference:	GL @ 2920.00usft
Project:	ATLAS PROSPECT_NME	MD Reference:	GL @ 2920.00usft
Site:	SWEET TEA FED COM PROJECT	North Reference:	Grid
Well:	_SWEET TEA FEDERAL COM 552H	Survey Calculation Method:	Minimum Curvature
Wellbore:	OWB		
Design:	PWP0		

Project	ATLAS PROSPECT_NME		
Map System:	US State Plane 1927 (Exact solution)	System Datum:	Mean Sea Level
Geo Datum:	NAD 1927 (NADCON CONUS)		
Map Zone:	New Mexico East 3001		

Site	SWEET TEA FED COM PROJECT				
Site Position:		Northing:	426,998.11 usft	Latitude:	32° 10' 24.821 N
From:	Map	Easting:	595,092.19 usft	Longitude:	104° 1' 33.598 W
Position Uncertainty:	0.00 usft	Slot Radius:	13-3/16 "		

Well	_SWEET TEA FEDERAL COM 552H					
Well Position	+N/-S	0.00 usft	Northing:	426,998.11 usft	Latitude:	32° 10' 24.821 N
	+E/-W	0.00 usft	Easting:	595,092.19 usft	Longitude:	104° 1' 33.598 W
Position Uncertainty		0.00 usft	Wellhead Elevation:	usft	Ground Level:	2,904.00 usft
Grid Convergence:	0.16 °					

Wellbore	OWB				
Magnetics	Model Name	Sample Date	Declination (°)	Dip Angle (°)	Field Strength (nT)
	BGGM2025	3/1/2026	6.47	59.72	47,084.09595389

Design	PWP0			
Audit Notes:				
Version:	Phase:	PLAN	Tie On Depth:	0.00
Vertical Section:	Depth From (TVD) (usft)	+N/-S (usft)	+E/-W (usft)	Direction (°)
	0.00	0.00	0.00	186.37

Plan Survey Tool Program	Date	2/11/2026		
Depth From (usft)	Depth To (usft)	Survey (Wellbore)	Tool Name	Remarks
1	0.00	16,508.52 PWP0 (OWB)	r.5 MWD+IFR1 OWSG MWD + IFR1 rev.5	

ConocoPhillips

Planning Report

Database:	EDT 17 Permian Prod	Local Co-ordinate Reference:	Well _SWEET TEA FEDERAL COM 552H
Company:	DELAWARE BASIN WEST	TVD Reference:	GL @ 2920.00usft
Project:	ATLAS PROSPECT_NME	MD Reference:	GL @ 2920.00usft
Site:	SWEET TEA FED COM PROJECT	North Reference:	Grid
Well:	_SWEET TEA FEDERAL COM 552H	Survey Calculation Method:	Minimum Curvature
Wellbore:	OWB		
Design:	PWP0		

Plan Sections										
Measured Depth (usft)	Inclination (°)	Azimuth (°)	Vertical Depth (usft)	+N/-S (usft)	+E/-W (usft)	Dogleg Rate (°/100usft)	Build Rate (°/100usft)	Turn Rate (°/100usft)	TFO (°)	Target
0.00	0.00	0.00	0.00	0.00	0.00	0.00	0.00	0.00	0.00	
1,500.00	0.00	0.00	1,500.00	0.00	0.00	0.00	0.00	0.00	0.00	
1,900.00	8.00	210.00	1,898.70	-24.14	-13.94	2.00	2.00	0.00	210.00	
2,100.00	8.00	210.00	2,096.76	-48.25	-27.86	0.00	0.00	0.00	0.00	
2,563.37	10.31	269.43	2,555.13	-76.65	-85.57	2.00	0.50	12.83	106.89	
6,547.11	10.31	269.43	6,474.55	-83.76	-798.52	0.00	0.00	0.00	0.00	
7,578.12	0.00	0.00	7,500.00	-84.68	-891.03	1.00	-1.00	0.00	180.00	
8,434.66	0.00	0.00	8,356.54	-84.68	-891.03	0.00	0.00	0.00	0.00	
9,184.66	90.00	179.92	8,834.01	-562.14	-890.34	12.00	12.00	23.99	179.92	
16,508.52	90.00	179.92	8,834.00	-7,886.00	-879.73	0.00	0.00	0.00	0.00	

ConocoPhillips

Planning Report

Database:	EDT 17 Permian Prod	Local Co-ordinate Reference:	Well _SWEET TEA FEDERAL COM 552H
Company:	DELAWARE BASIN WEST	TVD Reference:	GL @ 2920.00usft
Project:	ATLAS PROSPECT_NME	MD Reference:	GL @ 2920.00usft
Site:	SWEET TEA FED COM PROJECT	North Reference:	Grid
Well:	_SWEET TEA FEDERAL COM 552H	Survey Calculation Method:	Minimum Curvature
Wellbore:	OWB		
Design:	PWP0		

Planned Survey									
Measured Depth (usft)	Inclination (°)	Azimuth (°)	Vertical Depth (usft)	+N/-S (usft)	+E/-W (usft)	Vertical Section (usft)	Dogleg Rate (°/100usft)	Build Rate (°/100usft)	Turn Rate (°/100usft)
0.00	0.00	0.00	0.00	0.00	0.00	0.00	0.00	0.00	0.00
15.00	0.00	0.00	15.00	0.00	0.00	0.00	0.00	0.00	0.00
30.00	0.00	0.00	30.00	0.00	0.00	0.00	0.00	0.00	0.00
45.00	0.00	0.00	45.00	0.00	0.00	0.00	0.00	0.00	0.00
60.00	0.00	0.00	60.00	0.00	0.00	0.00	0.00	0.00	0.00
75.00	0.00	0.00	75.00	0.00	0.00	0.00	0.00	0.00	0.00
90.00	0.00	0.00	90.00	0.00	0.00	0.00	0.00	0.00	0.00
105.00	0.00	0.00	105.00	0.00	0.00	0.00	0.00	0.00	0.00
120.00	0.00	0.00	120.00	0.00	0.00	0.00	0.00	0.00	0.00
135.00	0.00	0.00	135.00	0.00	0.00	0.00	0.00	0.00	0.00
150.00	0.00	0.00	150.00	0.00	0.00	0.00	0.00	0.00	0.00
165.00	0.00	0.00	165.00	0.00	0.00	0.00	0.00	0.00	0.00
180.00	0.00	0.00	180.00	0.00	0.00	0.00	0.00	0.00	0.00
195.00	0.00	0.00	195.00	0.00	0.00	0.00	0.00	0.00	0.00
210.00	0.00	0.00	210.00	0.00	0.00	0.00	0.00	0.00	0.00
225.00	0.00	0.00	225.00	0.00	0.00	0.00	0.00	0.00	0.00
240.00	0.00	0.00	240.00	0.00	0.00	0.00	0.00	0.00	0.00
255.00	0.00	0.00	255.00	0.00	0.00	0.00	0.00	0.00	0.00
270.00	0.00	0.00	270.00	0.00	0.00	0.00	0.00	0.00	0.00
285.00	0.00	0.00	285.00	0.00	0.00	0.00	0.00	0.00	0.00
300.00	0.00	0.00	300.00	0.00	0.00	0.00	0.00	0.00	0.00
315.00	0.00	0.00	315.00	0.00	0.00	0.00	0.00	0.00	0.00
330.00	0.00	0.00	330.00	0.00	0.00	0.00	0.00	0.00	0.00
345.00	0.00	0.00	345.00	0.00	0.00	0.00	0.00	0.00	0.00
360.00	0.00	0.00	360.00	0.00	0.00	0.00	0.00	0.00	0.00
375.00	0.00	0.00	375.00	0.00	0.00	0.00	0.00	0.00	0.00
390.00	0.00	0.00	390.00	0.00	0.00	0.00	0.00	0.00	0.00
405.00	0.00	0.00	405.00	0.00	0.00	0.00	0.00	0.00	0.00
420.00	0.00	0.00	420.00	0.00	0.00	0.00	0.00	0.00	0.00
435.00	0.00	0.00	435.00	0.00	0.00	0.00	0.00	0.00	0.00
450.00	0.00	0.00	450.00	0.00	0.00	0.00	0.00	0.00	0.00
465.00	0.00	0.00	465.00	0.00	0.00	0.00	0.00	0.00	0.00
480.00	0.00	0.00	480.00	0.00	0.00	0.00	0.00	0.00	0.00
495.00	0.00	0.00	495.00	0.00	0.00	0.00	0.00	0.00	0.00
510.00	0.00	0.00	510.00	0.00	0.00	0.00	0.00	0.00	0.00
525.00	0.00	0.00	525.00	0.00	0.00	0.00	0.00	0.00	0.00
540.00	0.00	0.00	540.00	0.00	0.00	0.00	0.00	0.00	0.00
555.00	0.00	0.00	555.00	0.00	0.00	0.00	0.00	0.00	0.00
570.00	0.00	0.00	570.00	0.00	0.00	0.00	0.00	0.00	0.00
585.00	0.00	0.00	585.00	0.00	0.00	0.00	0.00	0.00	0.00
600.00	0.00	0.00	600.00	0.00	0.00	0.00	0.00	0.00	0.00
615.00	0.00	0.00	615.00	0.00	0.00	0.00	0.00	0.00	0.00
630.00	0.00	0.00	630.00	0.00	0.00	0.00	0.00	0.00	0.00
645.00	0.00	0.00	645.00	0.00	0.00	0.00	0.00	0.00	0.00
660.00	0.00	0.00	660.00	0.00	0.00	0.00	0.00	0.00	0.00
675.00	0.00	0.00	675.00	0.00	0.00	0.00	0.00	0.00	0.00
690.00	0.00	0.00	690.00	0.00	0.00	0.00	0.00	0.00	0.00
705.00	0.00	0.00	705.00	0.00	0.00	0.00	0.00	0.00	0.00
720.00	0.00	0.00	720.00	0.00	0.00	0.00	0.00	0.00	0.00
735.00	0.00	0.00	735.00	0.00	0.00	0.00	0.00	0.00	0.00
750.00	0.00	0.00	750.00	0.00	0.00	0.00	0.00	0.00	0.00
765.00	0.00	0.00	765.00	0.00	0.00	0.00	0.00	0.00	0.00
780.00	0.00	0.00	780.00	0.00	0.00	0.00	0.00	0.00	0.00
795.00	0.00	0.00	795.00	0.00	0.00	0.00	0.00	0.00	0.00

ConocoPhillips

Planning Report

Database:	EDT 17 Permian Prod	Local Co-ordinate Reference:	Well _SWEET TEA FEDERAL COM 552H
Company:	DELAWARE BASIN WEST	TVD Reference:	GL @ 2920.00usft
Project:	ATLAS PROSPECT_NME	MD Reference:	GL @ 2920.00usft
Site:	SWEET TEA FED COM PROJECT	North Reference:	Grid
Well:	_SWEET TEA FEDERAL COM 552H	Survey Calculation Method:	Minimum Curvature
Wellbore:	OWB		
Design:	PWPO		

Planned Survey										
Measured Depth (usft)	Inclination (°)	Azimuth (°)	Vertical Depth (usft)	+N/-S (usft)	+E/-W (usft)	Vertical Section (usft)	Dogleg Rate (°/100usft)	Build Rate (°/100usft)	Turn Rate (°/100usft)	
810.00	0.00	0.00	810.00	0.00	0.00	0.00	0.00	0.00	0.00	0.00
825.00	0.00	0.00	825.00	0.00	0.00	0.00	0.00	0.00	0.00	0.00
840.00	0.00	0.00	840.00	0.00	0.00	0.00	0.00	0.00	0.00	0.00
855.00	0.00	0.00	855.00	0.00	0.00	0.00	0.00	0.00	0.00	0.00
870.00	0.00	0.00	870.00	0.00	0.00	0.00	0.00	0.00	0.00	0.00
885.00	0.00	0.00	885.00	0.00	0.00	0.00	0.00	0.00	0.00	0.00
900.00	0.00	0.00	900.00	0.00	0.00	0.00	0.00	0.00	0.00	0.00
915.00	0.00	0.00	915.00	0.00	0.00	0.00	0.00	0.00	0.00	0.00
930.00	0.00	0.00	930.00	0.00	0.00	0.00	0.00	0.00	0.00	0.00
945.00	0.00	0.00	945.00	0.00	0.00	0.00	0.00	0.00	0.00	0.00
960.00	0.00	0.00	960.00	0.00	0.00	0.00	0.00	0.00	0.00	0.00
975.00	0.00	0.00	975.00	0.00	0.00	0.00	0.00	0.00	0.00	0.00
990.00	0.00	0.00	990.00	0.00	0.00	0.00	0.00	0.00	0.00	0.00
1,005.00	0.00	0.00	1,005.00	0.00	0.00	0.00	0.00	0.00	0.00	0.00
1,020.00	0.00	0.00	1,020.00	0.00	0.00	0.00	0.00	0.00	0.00	0.00
1,035.00	0.00	0.00	1,035.00	0.00	0.00	0.00	0.00	0.00	0.00	0.00
1,050.00	0.00	0.00	1,050.00	0.00	0.00	0.00	0.00	0.00	0.00	0.00
1,065.00	0.00	0.00	1,065.00	0.00	0.00	0.00	0.00	0.00	0.00	0.00
1,080.00	0.00	0.00	1,080.00	0.00	0.00	0.00	0.00	0.00	0.00	0.00
1,095.00	0.00	0.00	1,095.00	0.00	0.00	0.00	0.00	0.00	0.00	0.00
1,110.00	0.00	0.00	1,110.00	0.00	0.00	0.00	0.00	0.00	0.00	0.00
1,125.00	0.00	0.00	1,125.00	0.00	0.00	0.00	0.00	0.00	0.00	0.00
1,140.00	0.00	0.00	1,140.00	0.00	0.00	0.00	0.00	0.00	0.00	0.00
1,155.00	0.00	0.00	1,155.00	0.00	0.00	0.00	0.00	0.00	0.00	0.00
1,170.00	0.00	0.00	1,170.00	0.00	0.00	0.00	0.00	0.00	0.00	0.00
1,185.00	0.00	0.00	1,185.00	0.00	0.00	0.00	0.00	0.00	0.00	0.00
1,200.00	0.00	0.00	1,200.00	0.00	0.00	0.00	0.00	0.00	0.00	0.00
1,215.00	0.00	0.00	1,215.00	0.00	0.00	0.00	0.00	0.00	0.00	0.00
1,230.00	0.00	0.00	1,230.00	0.00	0.00	0.00	0.00	0.00	0.00	0.00
1,245.00	0.00	0.00	1,245.00	0.00	0.00	0.00	0.00	0.00	0.00	0.00
1,260.00	0.00	0.00	1,260.00	0.00	0.00	0.00	0.00	0.00	0.00	0.00
1,275.00	0.00	0.00	1,275.00	0.00	0.00	0.00	0.00	0.00	0.00	0.00
1,290.00	0.00	0.00	1,290.00	0.00	0.00	0.00	0.00	0.00	0.00	0.00
1,305.00	0.00	0.00	1,305.00	0.00	0.00	0.00	0.00	0.00	0.00	0.00
1,320.00	0.00	0.00	1,320.00	0.00	0.00	0.00	0.00	0.00	0.00	0.00
1,335.00	0.00	0.00	1,335.00	0.00	0.00	0.00	0.00	0.00	0.00	0.00
1,350.00	0.00	0.00	1,350.00	0.00	0.00	0.00	0.00	0.00	0.00	0.00
1,365.00	0.00	0.00	1,365.00	0.00	0.00	0.00	0.00	0.00	0.00	0.00
1,380.00	0.00	0.00	1,380.00	0.00	0.00	0.00	0.00	0.00	0.00	0.00
1,395.00	0.00	0.00	1,395.00	0.00	0.00	0.00	0.00	0.00	0.00	0.00
1,410.00	0.00	0.00	1,410.00	0.00	0.00	0.00	0.00	0.00	0.00	0.00
1,425.00	0.00	0.00	1,425.00	0.00	0.00	0.00	0.00	0.00	0.00	0.00
1,440.00	0.00	0.00	1,440.00	0.00	0.00	0.00	0.00	0.00	0.00	0.00
1,455.00	0.00	0.00	1,455.00	0.00	0.00	0.00	0.00	0.00	0.00	0.00
1,470.00	0.00	0.00	1,470.00	0.00	0.00	0.00	0.00	0.00	0.00	0.00
1,485.00	0.00	0.00	1,485.00	0.00	0.00	0.00	0.00	0.00	0.00	0.00
1,500.00	0.00	0.00	1,500.00	0.00	0.00	0.00	0.00	0.00	0.00	0.00
1,515.00	0.30	210.00	1,515.00	-0.03	-0.02	0.04	2.00	2.00	0.00	0.00
1,530.00	0.60	210.00	1,530.00	-0.14	-0.08	0.14	2.00	2.00	0.00	0.00
1,545.00	0.90	210.00	1,545.00	-0.31	-0.18	0.32	2.00	2.00	0.00	0.00
1,560.00	1.20	210.00	1,560.00	-0.54	-0.31	0.58	2.00	2.00	0.00	0.00
1,575.00	1.50	210.00	1,574.99	-0.85	-0.49	0.90	2.00	2.00	0.00	0.00
1,590.00	1.80	210.00	1,589.99	-1.22	-0.71	1.30	2.00	2.00	0.00	0.00
1,605.00	2.10	210.00	1,604.98	-1.67	-0.96	1.76	2.00	2.00	0.00	0.00

ConocoPhillips

Planning Report

Database:	EDT 17 Permian Prod	Local Co-ordinate Reference:	Well _SWEET TEA FEDERAL COM 552H
Company:	DELAWARE BASIN WEST	TVD Reference:	GL @ 2920.00usft
Project:	ATLAS PROSPECT_NME	MD Reference:	GL @ 2920.00usft
Site:	SWEET TEA FED COM PROJECT	North Reference:	Grid
Well:	_SWEET TEA FEDERAL COM 552H	Survey Calculation Method:	Minimum Curvature
Wellbore:	OWB		
Design:	PWPO		

Planned Survey										
Measured Depth (usft)	Inclination (°)	Azimuth (°)	Vertical Depth (usft)	+N/-S (usft)	+E/-W (usft)	Vertical Section (usft)	Dogleg Rate (°/100usft)	Build Rate (°/100usft)	Turn Rate (°/100usft)	
1,620.00	2.40	210.00	1,619.96	-2.18	-1.26	2.30	2.00	2.00	0.00	
1,635.00	2.70	210.00	1,634.95	-2.75	-1.59	2.91	2.00	2.00	0.00	
1,650.00	3.00	210.00	1,649.93	-3.40	-1.96	3.60	2.00	2.00	0.00	
1,665.00	3.30	210.00	1,664.91	-4.11	-2.38	4.35	2.00	2.00	0.00	
1,680.00	3.60	210.00	1,679.88	-4.90	-2.83	5.18	2.00	2.00	0.00	
1,695.00	3.90	210.00	1,694.85	-5.75	-3.32	6.08	2.00	2.00	0.00	
1,710.00	4.20	210.00	1,709.81	-6.66	-3.85	7.05	2.00	2.00	0.00	
1,725.00	4.50	210.00	1,724.77	-7.65	-4.42	8.09	2.00	2.00	0.00	
1,740.00	4.80	210.00	1,739.72	-8.70	-5.02	9.20	2.00	2.00	0.00	
1,755.00	5.10	210.00	1,754.66	-9.82	-5.67	10.39	2.00	2.00	0.00	
1,770.00	5.40	210.00	1,769.60	-11.01	-6.36	11.65	2.00	2.00	0.00	
1,785.00	5.70	210.00	1,784.53	-12.27	-7.08	12.98	2.00	2.00	0.00	
1,800.00	6.00	210.00	1,799.45	-13.59	-7.85	14.38	2.00	2.00	0.00	
1,815.00	6.30	210.00	1,814.37	-14.98	-8.65	15.85	2.00	2.00	0.00	
1,830.00	6.60	210.00	1,829.27	-16.44	-9.49	17.39	2.00	2.00	0.00	
1,845.00	6.90	210.00	1,844.17	-17.97	-10.37	19.01	2.00	2.00	0.00	
1,860.00	7.20	210.00	1,859.05	-19.56	-11.29	20.69	2.00	2.00	0.00	
1,875.00	7.50	210.00	1,873.93	-21.23	-12.25	22.45	2.00	2.00	0.00	
1,890.00	7.80	210.00	1,888.80	-22.95	-13.25	24.28	2.00	2.00	0.00	
1,900.00	8.00	210.00	1,898.70	-24.14	-13.94	25.54	2.00	2.00	0.00	
1,905.00	8.00	210.00	1,903.65	-24.75	-14.29	26.18	0.00	0.00	0.00	
1,920.00	8.00	210.00	1,918.51	-26.56	-15.33	28.09	0.00	0.00	0.00	
1,935.00	8.00	210.00	1,933.36	-28.36	-16.38	30.00	0.00	0.00	0.00	
1,950.00	8.00	210.00	1,948.22	-30.17	-17.42	31.92	0.00	0.00	0.00	
1,965.00	8.00	210.00	1,963.07	-31.98	-18.46	33.83	0.00	0.00	0.00	
1,980.00	8.00	210.00	1,977.92	-33.79	-19.51	35.74	0.00	0.00	0.00	
1,995.00	8.00	210.00	1,992.78	-35.59	-20.55	37.65	0.00	0.00	0.00	
2,010.00	8.00	210.00	2,007.63	-37.40	-21.59	39.57	0.00	0.00	0.00	
2,025.00	8.00	210.00	2,022.49	-39.21	-22.64	41.48	0.00	0.00	0.00	
2,040.00	8.00	210.00	2,037.34	-41.02	-23.68	43.39	0.00	0.00	0.00	
2,055.00	8.00	210.00	2,052.19	-42.83	-24.73	45.30	0.00	0.00	0.00	
2,070.00	8.00	210.00	2,067.05	-44.63	-25.77	47.22	0.00	0.00	0.00	
2,085.00	8.00	210.00	2,081.90	-46.44	-26.81	49.13	0.00	0.00	0.00	
2,100.00	8.00	210.00	2,096.76	-48.25	-27.86	51.04	0.00	0.00	0.00	
2,115.00	7.92	212.08	2,111.61	-50.03	-28.93	52.93	2.00	-0.55	13.90	
2,130.00	7.85	214.21	2,126.47	-51.75	-30.05	54.76	2.00	-0.48	14.17	
2,145.00	7.79	216.37	2,141.33	-53.42	-31.23	56.55	2.00	-0.40	14.40	
2,160.00	7.74	218.56	2,156.19	-55.02	-32.46	58.28	2.00	-0.33	14.61	
2,175.00	7.70	220.78	2,171.06	-56.57	-33.75	59.97	2.00	-0.25	14.77	
2,190.00	7.67	223.01	2,185.92	-58.07	-35.09	61.60	2.00	-0.18	14.90	
2,205.00	7.66	225.26	2,200.79	-59.50	-36.48	63.18	2.00	-0.10	14.98	
2,220.00	7.65	227.51	2,215.65	-60.88	-37.93	64.71	2.00	-0.02	15.01	
2,235.00	7.66	229.76	2,230.52	-62.20	-39.43	66.19	2.00	0.06	15.01	
2,250.00	7.68	232.00	2,245.39	-63.46	-40.98	67.62	2.00	0.13	14.95	
2,265.00	7.71	234.23	2,260.25	-64.67	-42.59	68.99	2.00	0.21	14.85	
2,280.00	7.76	236.44	2,275.11	-65.82	-44.25	70.32	2.00	0.29	14.71	
2,295.00	7.81	238.62	2,289.98	-66.91	-45.96	71.59	2.00	0.36	14.53	
2,310.00	7.87	240.76	2,304.84	-67.94	-47.73	72.81	2.00	0.43	14.31	
2,325.00	7.95	242.87	2,319.69	-68.92	-49.55	73.98	2.00	0.51	14.06	
2,340.00	8.04	244.94	2,334.55	-69.83	-51.42	75.10	2.00	0.58	13.78	
2,355.00	8.13	246.96	2,349.40	-70.69	-53.35	76.17	2.00	0.64	13.47	
2,370.00	8.24	248.93	2,364.25	-71.49	-55.32	77.19	2.00	0.71	13.14	
2,385.00	8.35	250.85	2,379.09	-72.24	-57.36	78.15	2.00	0.77	12.79	
2,400.00	8.48	252.71	2,393.93	-72.92	-59.44	79.06	2.00	0.83	12.43	

ConocoPhillips

Planning Report

Database:	EDT 17 Permian Prod	Local Co-ordinate Reference:	Well _SWEET TEA FEDERAL COM 552H
Company:	DELAWARE BASIN WEST	TVD Reference:	GL @ 2920.00usft
Project:	ATLAS PROSPECT_NME	MD Reference:	GL @ 2920.00usft
Site:	SWEET TEA FED COM PROJECT	North Reference:	Grid
Well:	_SWEET TEA FEDERAL COM 552H	Survey Calculation Method:	Minimum Curvature
Wellbore:	OWB		
Design:	PWP0		

Planned Survey									
Measured Depth (usft)	Inclination (°)	Azimuth (°)	Vertical Depth (usft)	+N/-S (usft)	+E/-W (usft)	Vertical Section (usft)	Dogleg Rate (°/100usft)	Build Rate (°/100usft)	Turn Rate (°/100usft)
2,415.00	8.61	254.52	2,408.76	-73.55	-61.58	79.93	2.00	0.89	12.06
2,430.00	8.75	256.28	2,423.59	-74.12	-63.77	80.74	2.00	0.94	11.69
2,445.00	8.90	257.97	2,438.41	-74.64	-66.02	81.49	2.00	0.99	11.31
2,460.00	9.06	259.61	2,453.23	-75.09	-68.31	82.20	2.00	1.04	10.93
2,475.00	9.22	261.20	2,468.04	-75.49	-70.66	82.86	2.00	1.09	10.56
2,490.00	9.39	262.72	2,482.84	-75.83	-73.06	83.46	2.00	1.13	10.18
2,505.00	9.57	264.20	2,497.63	-76.11	-75.52	84.01	2.00	1.18	9.82
2,520.00	9.75	265.62	2,512.42	-76.33	-78.03	84.51	2.00	1.22	9.46
2,535.00	9.94	266.98	2,527.20	-76.50	-80.59	84.96	2.00	1.25	9.11
2,550.00	10.13	268.30	2,541.97	-76.60	-83.20	85.35	2.00	1.29	8.77
2,563.37	10.31	269.43	2,555.13	-76.65	-85.57	85.66	2.00	1.32	8.46
2,565.00	10.31	269.43	2,556.73	-76.65	-85.86	85.70	0.00	0.00	0.00
2,580.00	10.31	269.43	2,571.49	-76.68	-88.55	86.02	0.00	0.00	0.00
2,595.00	10.31	269.43	2,586.25	-76.71	-91.23	86.35	0.00	0.00	0.00
2,610.00	10.31	269.43	2,601.01	-76.73	-93.91	86.67	0.00	0.00	0.00
2,625.00	10.31	269.43	2,615.76	-76.76	-96.60	87.00	0.00	0.00	0.00
2,640.00	10.31	269.43	2,630.52	-76.79	-99.28	87.32	0.00	0.00	0.00
2,655.00	10.31	269.43	2,645.28	-76.81	-101.97	87.64	0.00	0.00	0.00
2,670.00	10.31	269.43	2,660.04	-76.84	-104.65	87.97	0.00	0.00	0.00
2,685.00	10.31	269.43	2,674.80	-76.87	-107.34	88.29	0.00	0.00	0.00
2,700.00	10.31	269.43	2,689.55	-76.89	-110.02	88.62	0.00	0.00	0.00
2,715.00	10.31	269.43	2,704.31	-76.92	-112.71	88.94	0.00	0.00	0.00
2,730.00	10.31	269.43	2,719.07	-76.95	-115.39	89.27	0.00	0.00	0.00
2,745.00	10.31	269.43	2,733.83	-76.97	-118.07	89.59	0.00	0.00	0.00
2,760.00	10.31	269.43	2,748.58	-77.00	-120.76	89.91	0.00	0.00	0.00
2,775.00	10.31	269.43	2,763.34	-77.03	-123.44	90.24	0.00	0.00	0.00
2,790.00	10.31	269.43	2,778.10	-77.05	-126.13	90.56	0.00	0.00	0.00
2,805.00	10.31	269.43	2,792.86	-77.08	-128.81	90.89	0.00	0.00	0.00
2,820.00	10.31	269.43	2,807.62	-77.11	-131.50	91.21	0.00	0.00	0.00
2,835.00	10.31	269.43	2,822.37	-77.13	-134.18	91.54	0.00	0.00	0.00
2,850.00	10.31	269.43	2,837.13	-77.16	-136.87	91.86	0.00	0.00	0.00
2,865.00	10.31	269.43	2,851.89	-77.19	-139.55	92.18	0.00	0.00	0.00
2,880.00	10.31	269.43	2,866.65	-77.21	-142.23	92.51	0.00	0.00	0.00
2,895.00	10.31	269.43	2,881.40	-77.24	-144.92	92.83	0.00	0.00	0.00
2,910.00	10.31	269.43	2,896.16	-77.27	-147.60	93.16	0.00	0.00	0.00
2,925.00	10.31	269.43	2,910.92	-77.30	-150.29	93.48	0.00	0.00	0.00
2,940.00	10.31	269.43	2,925.68	-77.32	-152.97	93.81	0.00	0.00	0.00
2,955.00	10.31	269.43	2,940.44	-77.35	-155.66	94.13	0.00	0.00	0.00
2,970.00	10.31	269.43	2,955.19	-77.38	-158.34	94.45	0.00	0.00	0.00
2,985.00	10.31	269.43	2,969.95	-77.40	-161.03	94.78	0.00	0.00	0.00
3,000.00	10.31	269.43	2,984.71	-77.43	-163.71	95.10	0.00	0.00	0.00
3,015.00	10.31	269.43	2,999.47	-77.46	-166.40	95.43	0.00	0.00	0.00
3,030.00	10.31	269.43	3,014.23	-77.48	-169.08	95.75	0.00	0.00	0.00
3,045.00	10.31	269.43	3,028.98	-77.51	-171.76	96.07	0.00	0.00	0.00
3,060.00	10.31	269.43	3,043.74	-77.54	-174.45	96.40	0.00	0.00	0.00
3,075.00	10.31	269.43	3,058.50	-77.56	-177.13	96.72	0.00	0.00	0.00
3,090.00	10.31	269.43	3,073.26	-77.59	-179.82	97.05	0.00	0.00	0.00
3,105.00	10.31	269.43	3,088.01	-77.62	-182.50	97.37	0.00	0.00	0.00
3,120.00	10.31	269.43	3,102.77	-77.64	-185.19	97.70	0.00	0.00	0.00
3,135.00	10.31	269.43	3,117.53	-77.67	-187.87	98.02	0.00	0.00	0.00
3,150.00	10.31	269.43	3,132.29	-77.70	-190.56	98.34	0.00	0.00	0.00
3,165.00	10.31	269.43	3,147.05	-77.72	-193.24	98.67	0.00	0.00	0.00
3,180.00	10.31	269.43	3,161.80	-77.75	-195.92	98.99	0.00	0.00	0.00
3,195.00	10.31	269.43	3,176.56	-77.78	-198.61	99.32	0.00	0.00	0.00

ConocoPhillips

Planning Report

Database:	EDT 17 Permian Prod	Local Co-ordinate Reference:	Well _SWEET TEA FEDERAL COM 552H
Company:	DELAWARE BASIN WEST	TVD Reference:	GL @ 2920.00usft
Project:	ATLAS PROSPECT_NME	MD Reference:	GL @ 2920.00usft
Site:	SWEET TEA FED COM PROJECT	North Reference:	Grid
Well:	_SWEET TEA FEDERAL COM 552H	Survey Calculation Method:	Minimum Curvature
Wellbore:	OWB		
Design:	PWP0		

Planned Survey									
Measured Depth (usft)	Inclination (°)	Azimuth (°)	Vertical Depth (usft)	+N/-S (usft)	+E/-W (usft)	Vertical Section (usft)	Dogleg Rate (°/100usft)	Build Rate (°/100usft)	Turn Rate (°/100usft)
3,210.00	10.31	269.43	3,191.32	-77.80	-201.29	99.64	0.00	0.00	0.00
3,225.00	10.31	269.43	3,206.08	-77.83	-203.98	99.97	0.00	0.00	0.00
3,240.00	10.31	269.43	3,220.83	-77.86	-206.66	100.29	0.00	0.00	0.00
3,255.00	10.31	269.43	3,235.59	-77.88	-209.35	100.61	0.00	0.00	0.00
3,270.00	10.31	269.43	3,250.35	-77.91	-212.03	100.94	0.00	0.00	0.00
3,285.00	10.31	269.43	3,265.11	-77.94	-214.72	101.26	0.00	0.00	0.00
3,300.00	10.31	269.43	3,279.87	-77.96	-217.40	101.59	0.00	0.00	0.00
3,315.00	10.31	269.43	3,294.62	-77.99	-220.09	101.91	0.00	0.00	0.00
3,330.00	10.31	269.43	3,309.38	-78.02	-222.77	102.23	0.00	0.00	0.00
3,345.00	10.31	269.43	3,324.14	-78.04	-225.45	102.56	0.00	0.00	0.00
3,360.00	10.31	269.43	3,338.90	-78.07	-228.14	102.88	0.00	0.00	0.00
3,375.00	10.31	269.43	3,353.65	-78.10	-230.82	103.21	0.00	0.00	0.00
3,390.00	10.31	269.43	3,368.41	-78.12	-233.51	103.53	0.00	0.00	0.00
3,405.00	10.31	269.43	3,383.17	-78.15	-236.19	103.86	0.00	0.00	0.00
3,420.00	10.31	269.43	3,397.93	-78.18	-238.88	104.18	0.00	0.00	0.00
3,435.00	10.31	269.43	3,412.69	-78.21	-241.56	104.50	0.00	0.00	0.00
3,450.00	10.31	269.43	3,427.44	-78.23	-244.25	104.83	0.00	0.00	0.00
3,465.00	10.31	269.43	3,442.20	-78.26	-246.93	105.15	0.00	0.00	0.00
3,480.00	10.31	269.43	3,456.96	-78.29	-249.61	105.48	0.00	0.00	0.00
3,495.00	10.31	269.43	3,471.72	-78.31	-252.30	105.80	0.00	0.00	0.00
3,510.00	10.31	269.43	3,486.47	-78.34	-254.98	106.13	0.00	0.00	0.00
3,525.00	10.31	269.43	3,501.23	-78.37	-257.67	106.45	0.00	0.00	0.00
3,540.00	10.31	269.43	3,515.99	-78.39	-260.35	106.77	0.00	0.00	0.00
3,555.00	10.31	269.43	3,530.75	-78.42	-263.04	107.10	0.00	0.00	0.00
3,570.00	10.31	269.43	3,545.51	-78.45	-265.72	107.42	0.00	0.00	0.00
3,585.00	10.31	269.43	3,560.26	-78.47	-268.41	107.75	0.00	0.00	0.00
3,600.00	10.31	269.43	3,575.02	-78.50	-271.09	108.07	0.00	0.00	0.00
3,615.00	10.31	269.43	3,589.78	-78.53	-273.77	108.40	0.00	0.00	0.00
3,630.00	10.31	269.43	3,604.54	-78.55	-276.46	108.72	0.00	0.00	0.00
3,645.00	10.31	269.43	3,619.30	-78.58	-279.14	109.04	0.00	0.00	0.00
3,660.00	10.31	269.43	3,634.05	-78.61	-281.83	109.37	0.00	0.00	0.00
3,675.00	10.31	269.43	3,648.81	-78.63	-284.51	109.69	0.00	0.00	0.00
3,690.00	10.31	269.43	3,663.57	-78.66	-287.20	110.02	0.00	0.00	0.00
3,705.00	10.31	269.43	3,678.33	-78.69	-289.88	110.34	0.00	0.00	0.00
3,720.00	10.31	269.43	3,693.08	-78.71	-292.57	110.66	0.00	0.00	0.00
3,735.00	10.31	269.43	3,707.84	-78.74	-295.25	110.99	0.00	0.00	0.00
3,750.00	10.31	269.43	3,722.60	-78.77	-297.94	111.31	0.00	0.00	0.00
3,765.00	10.31	269.43	3,737.36	-78.79	-300.62	111.64	0.00	0.00	0.00
3,780.00	10.31	269.43	3,752.12	-78.82	-303.30	111.96	0.00	0.00	0.00
3,795.00	10.31	269.43	3,766.87	-78.85	-305.99	112.29	0.00	0.00	0.00
3,810.00	10.31	269.43	3,781.63	-78.87	-308.67	112.61	0.00	0.00	0.00
3,825.00	10.31	269.43	3,796.39	-78.90	-311.36	112.93	0.00	0.00	0.00
3,840.00	10.31	269.43	3,811.15	-78.93	-314.04	113.26	0.00	0.00	0.00
3,855.00	10.31	269.43	3,825.90	-78.95	-316.73	113.58	0.00	0.00	0.00
3,870.00	10.31	269.43	3,840.66	-78.98	-319.41	113.91	0.00	0.00	0.00
3,885.00	10.31	269.43	3,855.42	-79.01	-322.10	114.23	0.00	0.00	0.00
3,900.00	10.31	269.43	3,870.18	-79.03	-324.78	114.56	0.00	0.00	0.00
3,915.00	10.31	269.43	3,884.94	-79.06	-327.46	114.88	0.00	0.00	0.00
3,930.00	10.31	269.43	3,899.69	-79.09	-330.15	115.20	0.00	0.00	0.00
3,945.00	10.31	269.43	3,914.45	-79.12	-332.83	115.53	0.00	0.00	0.00
3,960.00	10.31	269.43	3,929.21	-79.14	-335.52	115.85	0.00	0.00	0.00
3,975.00	10.31	269.43	3,943.97	-79.17	-338.20	116.18	0.00	0.00	0.00
3,990.00	10.31	269.43	3,958.72	-79.20	-340.89	116.50	0.00	0.00	0.00
4,005.00	10.31	269.43	3,973.48	-79.22	-343.57	116.82	0.00	0.00	0.00

ConocoPhillips

Planning Report

Database:	EDT 17 Permian Prod	Local Co-ordinate Reference:	Well _SWEET TEA FEDERAL COM 552H
Company:	DELAWARE BASIN WEST	TVD Reference:	GL @ 2920.00usft
Project:	ATLAS PROSPECT_NME	MD Reference:	GL @ 2920.00usft
Site:	SWEET TEA FED COM PROJECT	North Reference:	Grid
Well:	_SWEET TEA FEDERAL COM 552H	Survey Calculation Method:	Minimum Curvature
Wellbore:	OWB		
Design:	PWP0		

Planned Survey									
Measured Depth (usft)	Inclination (°)	Azimuth (°)	Vertical Depth (usft)	+N/-S (usft)	+E/-W (usft)	Vertical Section (usft)	Dogleg Rate (°/100usft)	Build Rate (°/100usft)	Turn Rate (°/100usft)
4,020.00	10.31	269.43	3,988.24	-79.25	-346.26	117.15	0.00	0.00	0.00
4,035.00	10.31	269.43	4,003.00	-79.28	-348.94	117.47	0.00	0.00	0.00
4,050.00	10.31	269.43	4,017.76	-79.30	-351.62	117.80	0.00	0.00	0.00
4,065.00	10.31	269.43	4,032.51	-79.33	-354.31	118.12	0.00	0.00	0.00
4,080.00	10.31	269.43	4,047.27	-79.36	-356.99	118.45	0.00	0.00	0.00
4,095.00	10.31	269.43	4,062.03	-79.38	-359.68	118.77	0.00	0.00	0.00
4,110.00	10.31	269.43	4,076.79	-79.41	-362.36	119.09	0.00	0.00	0.00
4,125.00	10.31	269.43	4,091.54	-79.44	-365.05	119.42	0.00	0.00	0.00
4,140.00	10.31	269.43	4,106.30	-79.46	-367.73	119.74	0.00	0.00	0.00
4,155.00	10.31	269.43	4,121.06	-79.49	-370.42	120.07	0.00	0.00	0.00
4,170.00	10.31	269.43	4,135.82	-79.52	-373.10	120.39	0.00	0.00	0.00
4,185.00	10.31	269.43	4,150.58	-79.54	-375.79	120.72	0.00	0.00	0.00
4,200.00	10.31	269.43	4,165.33	-79.57	-378.47	121.04	0.00	0.00	0.00
4,215.00	10.31	269.43	4,180.09	-79.60	-381.15	121.36	0.00	0.00	0.00
4,230.00	10.31	269.43	4,194.85	-79.62	-383.84	121.69	0.00	0.00	0.00
4,245.00	10.31	269.43	4,209.61	-79.65	-386.52	122.01	0.00	0.00	0.00
4,260.00	10.31	269.43	4,224.37	-79.68	-389.21	122.34	0.00	0.00	0.00
4,275.00	10.31	269.43	4,239.12	-79.70	-391.89	122.66	0.00	0.00	0.00
4,290.00	10.31	269.43	4,253.88	-79.73	-394.58	122.99	0.00	0.00	0.00
4,305.00	10.31	269.43	4,268.64	-79.76	-397.26	123.31	0.00	0.00	0.00
4,320.00	10.31	269.43	4,283.40	-79.78	-399.95	123.63	0.00	0.00	0.00
4,335.00	10.31	269.43	4,298.15	-79.81	-402.63	123.96	0.00	0.00	0.00
4,350.00	10.31	269.43	4,312.91	-79.84	-405.31	124.28	0.00	0.00	0.00
4,365.00	10.31	269.43	4,327.67	-79.86	-408.00	124.61	0.00	0.00	0.00
4,380.00	10.31	269.43	4,342.43	-79.89	-410.68	124.93	0.00	0.00	0.00
4,395.00	10.31	269.43	4,357.19	-79.92	-413.37	125.25	0.00	0.00	0.00
4,410.00	10.31	269.43	4,371.94	-79.94	-416.05	125.58	0.00	0.00	0.00
4,425.00	10.31	269.43	4,386.70	-79.97	-418.74	125.90	0.00	0.00	0.00
4,440.00	10.31	269.43	4,401.46	-80.00	-421.42	126.23	0.00	0.00	0.00
4,455.00	10.31	269.43	4,416.22	-80.02	-424.11	126.55	0.00	0.00	0.00
4,470.00	10.31	269.43	4,430.97	-80.05	-426.79	126.88	0.00	0.00	0.00
4,485.00	10.31	269.43	4,445.73	-80.08	-429.48	127.20	0.00	0.00	0.00
4,500.00	10.31	269.43	4,460.49	-80.11	-432.16	127.52	0.00	0.00	0.00
4,515.00	10.31	269.43	4,475.25	-80.13	-434.84	127.85	0.00	0.00	0.00
4,530.00	10.31	269.43	4,490.01	-80.16	-437.53	128.17	0.00	0.00	0.00
4,545.00	10.31	269.43	4,504.76	-80.19	-440.21	128.50	0.00	0.00	0.00
4,560.00	10.31	269.43	4,519.52	-80.21	-442.90	128.82	0.00	0.00	0.00
4,575.00	10.31	269.43	4,534.28	-80.24	-445.58	129.15	0.00	0.00	0.00
4,590.00	10.31	269.43	4,549.04	-80.27	-448.27	129.47	0.00	0.00	0.00
4,605.00	10.31	269.43	4,563.79	-80.29	-450.95	129.79	0.00	0.00	0.00
4,620.00	10.31	269.43	4,578.55	-80.32	-453.64	130.12	0.00	0.00	0.00
4,635.00	10.31	269.43	4,593.31	-80.35	-456.32	130.44	0.00	0.00	0.00
4,650.00	10.31	269.43	4,608.07	-80.37	-459.00	130.77	0.00	0.00	0.00
4,665.00	10.31	269.43	4,622.83	-80.40	-461.69	131.09	0.00	0.00	0.00
4,680.00	10.31	269.43	4,637.58	-80.43	-464.37	131.41	0.00	0.00	0.00
4,695.00	10.31	269.43	4,652.34	-80.45	-467.06	131.74	0.00	0.00	0.00
4,710.00	10.31	269.43	4,667.10	-80.48	-469.74	132.06	0.00	0.00	0.00
4,725.00	10.31	269.43	4,681.86	-80.51	-472.43	132.39	0.00	0.00	0.00
4,740.00	10.31	269.43	4,696.61	-80.53	-475.11	132.71	0.00	0.00	0.00
4,755.00	10.31	269.43	4,711.37	-80.56	-477.80	133.04	0.00	0.00	0.00
4,770.00	10.31	269.43	4,726.13	-80.59	-480.48	133.36	0.00	0.00	0.00
4,785.00	10.31	269.43	4,740.89	-80.61	-483.16	133.68	0.00	0.00	0.00
4,800.00	10.31	269.43	4,755.65	-80.64	-485.85	134.01	0.00	0.00	0.00
4,815.00	10.31	269.43	4,770.40	-80.67	-488.53	134.33	0.00	0.00	0.00

ConocoPhillips

Planning Report

Database:	EDT 17 Permian Prod	Local Co-ordinate Reference:	Well _SWEET TEA FEDERAL COM 552H
Company:	DELAWARE BASIN WEST	TVD Reference:	GL @ 2920.00usft
Project:	ATLAS PROSPECT_NME	MD Reference:	GL @ 2920.00usft
Site:	SWEET TEA FED COM PROJECT	North Reference:	Grid
Well:	_SWEET TEA FEDERAL COM 552H	Survey Calculation Method:	Minimum Curvature
Wellbore:	OWB		
Design:	PWP0		

Planned Survey									
Measured Depth (usft)	Inclination (°)	Azimuth (°)	Vertical Depth (usft)	+N/-S (usft)	+E/-W (usft)	Vertical Section (usft)	Dogleg Rate (°/100usft)	Build Rate (°/100usft)	Turn Rate (°/100usft)
4,830.00	10.31	269.43	4,785.16	-80.69	-491.22	134.66	0.00	0.00	0.00
4,845.00	10.31	269.43	4,799.92	-80.72	-493.90	134.98	0.00	0.00	0.00
4,860.00	10.31	269.43	4,814.68	-80.75	-496.59	135.31	0.00	0.00	0.00
4,875.00	10.31	269.43	4,829.44	-80.77	-499.27	135.63	0.00	0.00	0.00
4,890.00	10.31	269.43	4,844.19	-80.80	-501.96	135.95	0.00	0.00	0.00
4,905.00	10.31	269.43	4,858.95	-80.83	-504.64	136.28	0.00	0.00	0.00
4,920.00	10.31	269.43	4,873.71	-80.85	-507.33	136.60	0.00	0.00	0.00
4,935.00	10.31	269.43	4,888.47	-80.88	-510.01	136.93	0.00	0.00	0.00
4,950.00	10.31	269.43	4,903.22	-80.91	-512.69	137.25	0.00	0.00	0.00
4,965.00	10.31	269.43	4,917.98	-80.93	-515.38	137.58	0.00	0.00	0.00
4,980.00	10.31	269.43	4,932.74	-80.96	-518.06	137.90	0.00	0.00	0.00
4,995.00	10.31	269.43	4,947.50	-80.99	-520.75	138.22	0.00	0.00	0.00
5,010.00	10.31	269.43	4,962.26	-81.02	-523.43	138.55	0.00	0.00	0.00
5,025.00	10.31	269.43	4,977.01	-81.04	-526.12	138.87	0.00	0.00	0.00
5,040.00	10.31	269.43	4,991.77	-81.07	-528.80	139.20	0.00	0.00	0.00
5,055.00	10.31	269.43	5,006.53	-81.10	-531.49	139.52	0.00	0.00	0.00
5,070.00	10.31	269.43	5,021.29	-81.12	-534.17	139.84	0.00	0.00	0.00
5,085.00	10.31	269.43	5,036.04	-81.15	-536.85	140.17	0.00	0.00	0.00
5,100.00	10.31	269.43	5,050.80	-81.18	-539.54	140.49	0.00	0.00	0.00
5,115.00	10.31	269.43	5,065.56	-81.20	-542.22	140.82	0.00	0.00	0.00
5,130.00	10.31	269.43	5,080.32	-81.23	-544.91	141.14	0.00	0.00	0.00
5,145.00	10.31	269.43	5,095.08	-81.26	-547.59	141.47	0.00	0.00	0.00
5,160.00	10.31	269.43	5,109.83	-81.28	-550.28	141.79	0.00	0.00	0.00
5,175.00	10.31	269.43	5,124.59	-81.31	-552.96	142.11	0.00	0.00	0.00
5,190.00	10.31	269.43	5,139.35	-81.34	-555.65	142.44	0.00	0.00	0.00
5,205.00	10.31	269.43	5,154.11	-81.36	-558.33	142.76	0.00	0.00	0.00
5,220.00	10.31	269.43	5,168.86	-81.39	-561.01	143.09	0.00	0.00	0.00
5,235.00	10.31	269.43	5,183.62	-81.42	-563.70	143.41	0.00	0.00	0.00
5,250.00	10.31	269.43	5,198.38	-81.44	-566.38	143.74	0.00	0.00	0.00
5,265.00	10.31	269.43	5,213.14	-81.47	-569.07	144.06	0.00	0.00	0.00
5,280.00	10.31	269.43	5,227.90	-81.50	-571.75	144.38	0.00	0.00	0.00
5,295.00	10.31	269.43	5,242.65	-81.52	-574.44	144.71	0.00	0.00	0.00
5,310.00	10.31	269.43	5,257.41	-81.55	-577.12	145.03	0.00	0.00	0.00
5,325.00	10.31	269.43	5,272.17	-81.58	-579.81	145.36	0.00	0.00	0.00
5,340.00	10.31	269.43	5,286.93	-81.60	-582.49	145.68	0.00	0.00	0.00
5,355.00	10.31	269.43	5,301.68	-81.63	-585.18	146.00	0.00	0.00	0.00
5,370.00	10.31	269.43	5,316.44	-81.66	-587.86	146.33	0.00	0.00	0.00
5,385.00	10.31	269.43	5,331.20	-81.68	-590.54	146.65	0.00	0.00	0.00
5,400.00	10.31	269.43	5,345.96	-81.71	-593.23	146.98	0.00	0.00	0.00
5,415.00	10.31	269.43	5,360.72	-81.74	-595.91	147.30	0.00	0.00	0.00
5,430.00	10.31	269.43	5,375.47	-81.76	-598.60	147.63	0.00	0.00	0.00
5,445.00	10.31	269.43	5,390.23	-81.79	-601.28	147.95	0.00	0.00	0.00
5,460.00	10.31	269.43	5,404.99	-81.82	-603.97	148.27	0.00	0.00	0.00
5,475.00	10.31	269.43	5,419.75	-81.84	-606.65	148.60	0.00	0.00	0.00
5,490.00	10.31	269.43	5,434.51	-81.87	-609.34	148.92	0.00	0.00	0.00
5,505.00	10.31	269.43	5,449.26	-81.90	-612.02	149.25	0.00	0.00	0.00
5,520.00	10.31	269.43	5,464.02	-81.93	-614.70	149.57	0.00	0.00	0.00
5,535.00	10.31	269.43	5,478.78	-81.95	-617.39	149.90	0.00	0.00	0.00
5,550.00	10.31	269.43	5,493.54	-81.98	-620.07	150.22	0.00	0.00	0.00
5,565.00	10.31	269.43	5,508.29	-82.01	-622.76	150.54	0.00	0.00	0.00
5,580.00	10.31	269.43	5,523.05	-82.03	-625.44	150.87	0.00	0.00	0.00
5,595.00	10.31	269.43	5,537.81	-82.06	-628.13	151.19	0.00	0.00	0.00
5,610.00	10.31	269.43	5,552.57	-82.09	-630.81	151.52	0.00	0.00	0.00
5,625.00	10.31	269.43	5,567.33	-82.11	-633.50	151.84	0.00	0.00	0.00

ConocoPhillips

Planning Report

Database:	EDT 17 Permian Prod	Local Co-ordinate Reference:	Well _SWEET TEA FEDERAL COM 552H
Company:	DELAWARE BASIN WEST	TVD Reference:	GL @ 2920.00usft
Project:	ATLAS PROSPECT_NME	MD Reference:	GL @ 2920.00usft
Site:	SWEET TEA FED COM PROJECT	North Reference:	Grid
Well:	_SWEET TEA FEDERAL COM 552H	Survey Calculation Method:	Minimum Curvature
Wellbore:	OWB		
Design:	PWP0		

Planned Survey									
Measured Depth (usft)	Inclination (°)	Azimuth (°)	Vertical Depth (usft)	+N/-S (usft)	+E/-W (usft)	Vertical Section (usft)	Dogleg Rate (°/100usft)	Build Rate (°/100usft)	Turn Rate (°/100usft)
5,640.00	10.31	269.43	5,582.08	-82.14	-636.18	152.17	0.00	0.00	0.00
5,655.00	10.31	269.43	5,596.84	-82.17	-638.87	152.49	0.00	0.00	0.00
5,670.00	10.31	269.43	5,611.60	-82.19	-641.55	152.81	0.00	0.00	0.00
5,685.00	10.31	269.43	5,626.36	-82.22	-644.23	153.14	0.00	0.00	0.00
5,700.00	10.31	269.43	5,641.11	-82.25	-646.92	153.46	0.00	0.00	0.00
5,715.00	10.31	269.43	5,655.87	-82.27	-649.60	153.79	0.00	0.00	0.00
5,730.00	10.31	269.43	5,670.63	-82.30	-652.29	154.11	0.00	0.00	0.00
5,745.00	10.31	269.43	5,685.39	-82.33	-654.97	154.43	0.00	0.00	0.00
5,760.00	10.31	269.43	5,700.15	-82.35	-657.66	154.76	0.00	0.00	0.00
5,775.00	10.31	269.43	5,714.90	-82.38	-660.34	155.08	0.00	0.00	0.00
5,790.00	10.31	269.43	5,729.66	-82.41	-663.03	155.41	0.00	0.00	0.00
5,805.00	10.31	269.43	5,744.42	-82.43	-665.71	155.73	0.00	0.00	0.00
5,820.00	10.31	269.43	5,759.18	-82.46	-668.39	156.06	0.00	0.00	0.00
5,835.00	10.31	269.43	5,773.93	-82.49	-671.08	156.38	0.00	0.00	0.00
5,850.00	10.31	269.43	5,788.69	-82.51	-673.76	156.70	0.00	0.00	0.00
5,865.00	10.31	269.43	5,803.45	-82.54	-676.45	157.03	0.00	0.00	0.00
5,880.00	10.31	269.43	5,818.21	-82.57	-679.13	157.35	0.00	0.00	0.00
5,895.00	10.31	269.43	5,832.97	-82.59	-681.82	157.68	0.00	0.00	0.00
5,910.00	10.31	269.43	5,847.72	-82.62	-684.50	158.00	0.00	0.00	0.00
5,925.00	10.31	269.43	5,862.48	-82.65	-687.19	158.33	0.00	0.00	0.00
5,940.00	10.31	269.43	5,877.24	-82.67	-689.87	158.65	0.00	0.00	0.00
5,955.00	10.31	269.43	5,892.00	-82.70	-692.55	158.97	0.00	0.00	0.00
5,970.00	10.31	269.43	5,906.75	-82.73	-695.24	159.30	0.00	0.00	0.00
5,985.00	10.31	269.43	5,921.51	-82.75	-697.92	159.62	0.00	0.00	0.00
6,000.00	10.31	269.43	5,936.27	-82.78	-700.61	159.95	0.00	0.00	0.00
6,015.00	10.31	269.43	5,951.03	-82.81	-703.29	160.27	0.00	0.00	0.00
6,030.00	10.31	269.43	5,965.79	-82.84	-705.98	160.59	0.00	0.00	0.00
6,045.00	10.31	269.43	5,980.54	-82.86	-708.66	160.92	0.00	0.00	0.00
6,060.00	10.31	269.43	5,995.30	-82.89	-711.35	161.24	0.00	0.00	0.00
6,075.00	10.31	269.43	6,010.06	-82.92	-714.03	161.57	0.00	0.00	0.00
6,090.00	10.31	269.43	6,024.82	-82.94	-716.72	161.89	0.00	0.00	0.00
6,105.00	10.31	269.43	6,039.58	-82.97	-719.40	162.22	0.00	0.00	0.00
6,120.00	10.31	269.43	6,054.33	-83.00	-722.08	162.54	0.00	0.00	0.00
6,135.00	10.31	269.43	6,069.09	-83.02	-724.77	162.86	0.00	0.00	0.00
6,150.00	10.31	269.43	6,083.85	-83.05	-727.45	163.19	0.00	0.00	0.00
6,165.00	10.31	269.43	6,098.61	-83.08	-730.14	163.51	0.00	0.00	0.00
6,180.00	10.31	269.43	6,113.36	-83.10	-732.82	163.84	0.00	0.00	0.00
6,195.00	10.31	269.43	6,128.12	-83.13	-735.51	164.16	0.00	0.00	0.00
6,210.00	10.31	269.43	6,142.88	-83.16	-738.19	164.49	0.00	0.00	0.00
6,225.00	10.31	269.43	6,157.64	-83.18	-740.88	164.81	0.00	0.00	0.00
6,240.00	10.31	269.43	6,172.40	-83.21	-743.56	165.13	0.00	0.00	0.00
6,255.00	10.31	269.43	6,187.15	-83.24	-746.24	165.46	0.00	0.00	0.00
6,270.00	10.31	269.43	6,201.91	-83.26	-748.93	165.78	0.00	0.00	0.00
6,285.00	10.31	269.43	6,216.67	-83.29	-751.61	166.11	0.00	0.00	0.00
6,300.00	10.31	269.43	6,231.43	-83.32	-754.30	166.43	0.00	0.00	0.00
6,315.00	10.31	269.43	6,246.18	-83.34	-756.98	166.76	0.00	0.00	0.00
6,330.00	10.31	269.43	6,260.94	-83.37	-759.67	167.08	0.00	0.00	0.00
6,345.00	10.31	269.43	6,275.70	-83.40	-762.35	167.40	0.00	0.00	0.00
6,360.00	10.31	269.43	6,290.46	-83.42	-765.04	167.73	0.00	0.00	0.00
6,375.00	10.31	269.43	6,305.22	-83.45	-767.72	168.05	0.00	0.00	0.00
6,390.00	10.31	269.43	6,319.97	-83.48	-770.40	168.38	0.00	0.00	0.00
6,405.00	10.31	269.43	6,334.73	-83.50	-773.09	168.70	0.00	0.00	0.00
6,420.00	10.31	269.43	6,349.49	-83.53	-775.77	169.02	0.00	0.00	0.00
6,435.00	10.31	269.43	6,364.25	-83.56	-778.46	169.35	0.00	0.00	0.00

ConocoPhillips

Planning Report

Database:	EDT 17 Permian Prod	Local Co-ordinate Reference:	Well _SWEET TEA FEDERAL COM 552H
Company:	DELAWARE BASIN WEST	TVD Reference:	GL @ 2920.00usft
Project:	ATLAS PROSPECT_NME	MD Reference:	GL @ 2920.00usft
Site:	SWEET TEA FED COM PROJECT	North Reference:	Grid
Well:	_SWEET TEA FEDERAL COM 552H	Survey Calculation Method:	Minimum Curvature
Wellbore:	OWB		
Design:	PWPO		

Planned Survey										
Measured Depth (usft)	Inclination (°)	Azimuth (°)	Vertical Depth (usft)	+N/-S (usft)	+E/-W (usft)	Vertical Section (usft)	Dogleg Rate (°/100usft)	Build Rate (°/100usft)	Turn Rate (°/100usft)	
6,450.00	10.31	269.43	6,379.00	-83.58	-781.14	169.67	0.00	0.00	0.00	
6,465.00	10.31	269.43	6,393.76	-83.61	-783.83	170.00	0.00	0.00	0.00	
6,480.00	10.31	269.43	6,408.52	-83.64	-786.51	170.32	0.00	0.00	0.00	
6,495.00	10.31	269.43	6,423.28	-83.66	-789.20	170.65	0.00	0.00	0.00	
6,510.00	10.31	269.43	6,438.04	-83.69	-791.88	170.97	0.00	0.00	0.00	
6,525.00	10.31	269.43	6,452.79	-83.72	-794.57	171.29	0.00	0.00	0.00	
6,540.00	10.31	269.43	6,467.55	-83.75	-797.25	171.62	0.00	0.00	0.00	
6,547.11	10.31	269.43	6,474.55	-83.76	-798.52	171.77	0.00	0.00	0.00	
6,555.00	10.23	269.43	6,482.31	-83.77	-799.93	171.94	1.00	-1.00	0.00	
6,570.00	10.08	269.43	6,497.08	-83.80	-802.57	172.26	1.00	-1.00	0.00	
6,585.00	9.93	269.43	6,511.85	-83.82	-805.18	172.58	1.00	-1.00	0.00	
6,600.00	9.78	269.43	6,526.63	-83.85	-807.75	172.89	1.00	-1.00	0.00	
6,615.00	9.63	269.43	6,541.41	-83.87	-810.28	173.19	1.00	-1.00	0.00	
6,630.00	9.48	269.43	6,556.20	-83.90	-812.77	173.49	1.00	-1.00	0.00	
6,645.00	9.33	269.43	6,571.00	-83.92	-815.22	173.79	1.00	-1.00	0.00	
6,660.00	9.18	269.43	6,585.81	-83.95	-817.63	174.08	1.00	-1.00	0.00	
6,675.00	9.03	269.43	6,600.62	-83.97	-820.00	174.37	1.00	-1.00	0.00	
6,690.00	8.88	269.43	6,615.43	-84.00	-822.34	174.65	1.00	-1.00	0.00	
6,705.00	8.73	269.43	6,630.26	-84.02	-824.64	174.93	1.00	-1.00	0.00	
6,720.00	8.58	269.43	6,645.09	-84.04	-826.89	175.20	1.00	-1.00	0.00	
6,735.00	8.43	269.43	6,659.92	-84.06	-829.11	175.47	1.00	-1.00	0.00	
6,750.00	8.28	269.43	6,674.76	-84.08	-831.29	175.73	1.00	-1.00	0.00	
6,765.00	8.13	269.43	6,689.61	-84.11	-833.43	175.99	1.00	-1.00	0.00	
6,780.00	7.98	269.43	6,704.46	-84.13	-835.53	176.24	1.00	-1.00	0.00	
6,795.00	7.83	269.43	6,719.32	-84.15	-837.60	176.49	1.00	-1.00	0.00	
6,810.00	7.68	269.43	6,734.18	-84.17	-839.62	176.74	1.00	-1.00	0.00	
6,825.00	7.53	269.43	6,749.05	-84.19	-841.61	176.98	1.00	-1.00	0.00	
6,840.00	7.38	269.43	6,763.92	-84.21	-843.55	177.21	1.00	-1.00	0.00	
6,855.00	7.23	269.43	6,778.80	-84.23	-845.46	177.44	1.00	-1.00	0.00	
6,870.00	7.08	269.43	6,793.68	-84.24	-847.33	177.67	1.00	-1.00	0.00	
6,885.00	6.93	269.43	6,808.57	-84.26	-849.16	177.89	1.00	-1.00	0.00	
6,900.00	6.78	269.43	6,823.46	-84.28	-850.95	178.10	1.00	-1.00	0.00	
6,915.00	6.63	269.43	6,838.36	-84.30	-852.70	178.32	1.00	-1.00	0.00	
6,930.00	6.48	269.43	6,853.26	-84.31	-854.41	178.52	1.00	-1.00	0.00	
6,945.00	6.33	269.43	6,868.17	-84.33	-856.09	178.72	1.00	-1.00	0.00	
6,960.00	6.18	269.43	6,883.08	-84.35	-857.72	178.92	1.00	-1.00	0.00	
6,975.00	6.03	269.43	6,897.99	-84.36	-859.32	179.11	1.00	-1.00	0.00	
6,990.00	5.88	269.43	6,912.91	-84.38	-860.87	179.30	1.00	-1.00	0.00	
7,005.00	5.73	269.43	6,927.84	-84.39	-862.39	179.49	1.00	-1.00	0.00	
7,020.00	5.58	269.43	6,942.76	-84.41	-863.87	179.66	1.00	-1.00	0.00	
7,035.00	5.43	269.43	6,957.69	-84.42	-865.31	179.84	1.00	-1.00	0.00	
7,050.00	5.28	269.43	6,972.63	-84.44	-866.71	180.01	1.00	-1.00	0.00	
7,065.00	5.13	269.43	6,987.57	-84.45	-868.07	180.17	1.00	-1.00	0.00	
7,080.00	4.98	269.43	7,002.51	-84.46	-869.39	180.33	1.00	-1.00	0.00	
7,095.00	4.83	269.43	7,017.45	-84.48	-870.67	180.49	1.00	-1.00	0.00	
7,110.00	4.68	269.43	7,032.40	-84.49	-871.92	180.64	1.00	-1.00	0.00	
7,125.00	4.53	269.43	7,047.35	-84.50	-873.12	180.78	1.00	-1.00	0.00	
7,140.00	4.38	269.43	7,062.31	-84.51	-874.29	180.92	1.00	-1.00	0.00	
7,155.00	4.23	269.43	7,077.27	-84.52	-875.41	181.06	1.00	-1.00	0.00	
7,170.00	4.08	269.43	7,092.23	-84.54	-876.50	181.19	1.00	-1.00	0.00	
7,185.00	3.93	269.43	7,107.19	-84.55	-877.55	181.32	1.00	-1.00	0.00	
7,200.00	3.78	269.43	7,122.16	-84.56	-878.56	181.44	1.00	-1.00	0.00	
7,215.00	3.63	269.43	7,137.12	-84.57	-879.53	181.56	1.00	-1.00	0.00	
7,230.00	3.48	269.43	7,152.10	-84.57	-880.46	181.67	1.00	-1.00	0.00	

ConocoPhillips Planning Report

Database:	EDT 17 Permian Prod	Local Co-ordinate Reference:	Well _SWEET TEA FEDERAL COM 552H
Company:	DELAWARE BASIN WEST	TVD Reference:	GL @ 2920.00usft
Project:	ATLAS PROSPECT_NME	MD Reference:	GL @ 2920.00usft
Site:	SWEET TEA FED COM PROJECT	North Reference:	Grid
Well:	_SWEET TEA FEDERAL COM 552H	Survey Calculation Method:	Minimum Curvature
Wellbore:	OWB		
Design:	PWP0		

Planned Survey									
Measured Depth (usft)	Inclination (°)	Azimuth (°)	Vertical Depth (usft)	+N/-S (usft)	+E/-W (usft)	Vertical Section (usft)	Dogleg Rate (°/100usft)	Build Rate (°/100usft)	Turn Rate (°/100usft)
7,245.00	3.33	269.43	7,167.07	-84.58	-881.35	181.78	1.00	-1.00	0.00
7,260.00	3.18	269.43	7,182.05	-84.59	-882.20	181.88	1.00	-1.00	0.00
7,275.00	3.03	269.43	7,197.02	-84.60	-883.01	181.98	1.00	-1.00	0.00
7,290.00	2.88	269.43	7,212.00	-84.61	-883.79	182.07	1.00	-1.00	0.00
7,305.00	2.73	269.43	7,226.99	-84.62	-884.52	182.16	1.00	-1.00	0.00
7,320.00	2.58	269.43	7,241.97	-84.62	-885.22	182.24	1.00	-1.00	0.00
7,335.00	2.43	269.43	7,256.95	-84.63	-885.87	182.32	1.00	-1.00	0.00
7,350.00	2.28	269.43	7,271.94	-84.63	-886.49	182.40	1.00	-1.00	0.00
7,365.00	2.13	269.43	7,286.93	-84.64	-887.07	182.47	1.00	-1.00	0.00
7,380.00	1.98	269.43	7,301.92	-84.65	-887.61	182.53	1.00	-1.00	0.00
7,395.00	1.83	269.43	7,316.91	-84.65	-888.10	182.59	1.00	-1.00	0.00
7,410.00	1.68	269.43	7,331.91	-84.66	-888.56	182.65	1.00	-1.00	0.00
7,425.00	1.53	269.43	7,346.90	-84.66	-888.98	182.70	1.00	-1.00	0.00
7,440.00	1.38	269.43	7,361.90	-84.66	-889.37	182.74	1.00	-1.00	0.00
7,455.00	1.23	269.43	7,376.89	-84.67	-889.71	182.79	1.00	-1.00	0.00
7,470.00	1.08	269.43	7,391.89	-84.67	-890.01	182.82	1.00	-1.00	0.00
7,485.00	0.93	269.43	7,406.89	-84.67	-890.27	182.85	1.00	-1.00	0.00
7,500.00	0.78	269.43	7,421.88	-84.67	-890.50	182.88	1.00	-1.00	0.00
7,515.00	0.63	269.43	7,436.88	-84.68	-890.68	182.90	1.00	-1.00	0.00
7,530.00	0.48	269.43	7,451.88	-84.68	-890.83	182.92	1.00	-1.00	0.00
7,545.00	0.33	269.43	7,466.88	-84.68	-890.93	182.93	1.00	-1.00	0.00
7,560.00	0.18	269.43	7,481.88	-84.68	-891.00	182.94	1.00	-1.00	0.00
7,575.00	0.03	269.43	7,496.88	-84.68	-891.03	182.94	1.00	-1.00	0.00
7,578.12	0.00	0.00	7,500.00	-84.68	-891.03	182.94	1.00	-1.00	0.00
7,590.00	0.00	0.00	7,511.88	-84.68	-891.03	182.94	0.00	0.00	0.00
7,605.00	0.00	0.00	7,526.88	-84.68	-891.03	182.94	0.00	0.00	0.00
7,620.00	0.00	0.00	7,541.88	-84.68	-891.03	182.94	0.00	0.00	0.00
7,635.00	0.00	0.00	7,556.88	-84.68	-891.03	182.94	0.00	0.00	0.00
7,650.00	0.00	0.00	7,571.88	-84.68	-891.03	182.94	0.00	0.00	0.00
7,665.00	0.00	0.00	7,586.88	-84.68	-891.03	182.94	0.00	0.00	0.00
7,680.00	0.00	0.00	7,601.88	-84.68	-891.03	182.94	0.00	0.00	0.00
7,695.00	0.00	0.00	7,616.88	-84.68	-891.03	182.94	0.00	0.00	0.00
7,710.00	0.00	0.00	7,631.88	-84.68	-891.03	182.94	0.00	0.00	0.00
7,725.00	0.00	0.00	7,646.88	-84.68	-891.03	182.94	0.00	0.00	0.00
7,740.00	0.00	0.00	7,661.88	-84.68	-891.03	182.94	0.00	0.00	0.00
7,755.00	0.00	0.00	7,676.88	-84.68	-891.03	182.94	0.00	0.00	0.00
7,770.00	0.00	0.00	7,691.88	-84.68	-891.03	182.94	0.00	0.00	0.00
7,785.00	0.00	0.00	7,706.88	-84.68	-891.03	182.94	0.00	0.00	0.00
7,800.00	0.00	0.00	7,721.88	-84.68	-891.03	182.94	0.00	0.00	0.00
7,815.00	0.00	0.00	7,736.88	-84.68	-891.03	182.94	0.00	0.00	0.00
7,830.00	0.00	0.00	7,751.88	-84.68	-891.03	182.94	0.00	0.00	0.00
7,845.00	0.00	0.00	7,766.88	-84.68	-891.03	182.94	0.00	0.00	0.00
7,860.00	0.00	0.00	7,781.88	-84.68	-891.03	182.94	0.00	0.00	0.00
7,875.00	0.00	0.00	7,796.88	-84.68	-891.03	182.94	0.00	0.00	0.00
7,890.00	0.00	0.00	7,811.88	-84.68	-891.03	182.94	0.00	0.00	0.00
7,905.00	0.00	0.00	7,826.88	-84.68	-891.03	182.94	0.00	0.00	0.00
7,920.00	0.00	0.00	7,841.88	-84.68	-891.03	182.94	0.00	0.00	0.00
7,935.00	0.00	0.00	7,856.88	-84.68	-891.03	182.94	0.00	0.00	0.00
7,950.00	0.00	0.00	7,871.88	-84.68	-891.03	182.94	0.00	0.00	0.00
7,965.00	0.00	0.00	7,886.88	-84.68	-891.03	182.94	0.00	0.00	0.00
7,980.00	0.00	0.00	7,901.88	-84.68	-891.03	182.94	0.00	0.00	0.00
7,995.00	0.00	0.00	7,916.88	-84.68	-891.03	182.94	0.00	0.00	0.00
8,010.00	0.00	0.00	7,931.88	-84.68	-891.03	182.94	0.00	0.00	0.00
8,025.00	0.00	0.00	7,946.88	-84.68	-891.03	182.94	0.00	0.00	0.00

ConocoPhillips

Planning Report

Database:	EDT 17 Permian Prod	Local Co-ordinate Reference:	Well _SWEET TEA FEDERAL COM 552H
Company:	DELAWARE BASIN WEST	TVD Reference:	GL @ 2920.00usft
Project:	ATLAS PROSPECT_NME	MD Reference:	GL @ 2920.00usft
Site:	SWEET TEA FED COM PROJECT	North Reference:	Grid
Well:	_SWEET TEA FEDERAL COM 552H	Survey Calculation Method:	Minimum Curvature
Wellbore:	OWB		
Design:	PWP0		

Planned Survey									
Measured Depth (usft)	Inclination (°)	Azimuth (°)	Vertical Depth (usft)	+N/-S (usft)	+E/-W (usft)	Vertical Section (usft)	Dogleg Rate (°/100usft)	Build Rate (°/100usft)	Turn Rate (°/100usft)
8,040.00	0.00	0.00	7,961.88	-84.68	-891.03	182.94	0.00	0.00	0.00
8,055.00	0.00	0.00	7,976.88	-84.68	-891.03	182.94	0.00	0.00	0.00
8,070.00	0.00	0.00	7,991.88	-84.68	-891.03	182.94	0.00	0.00	0.00
8,085.00	0.00	0.00	8,006.88	-84.68	-891.03	182.94	0.00	0.00	0.00
8,100.00	0.00	0.00	8,021.88	-84.68	-891.03	182.94	0.00	0.00	0.00
8,115.00	0.00	0.00	8,036.88	-84.68	-891.03	182.94	0.00	0.00	0.00
8,130.00	0.00	0.00	8,051.88	-84.68	-891.03	182.94	0.00	0.00	0.00
8,145.00	0.00	0.00	8,066.88	-84.68	-891.03	182.94	0.00	0.00	0.00
8,160.00	0.00	0.00	8,081.88	-84.68	-891.03	182.94	0.00	0.00	0.00
8,175.00	0.00	0.00	8,096.88	-84.68	-891.03	182.94	0.00	0.00	0.00
8,190.00	0.00	0.00	8,111.88	-84.68	-891.03	182.94	0.00	0.00	0.00
8,205.00	0.00	0.00	8,126.88	-84.68	-891.03	182.94	0.00	0.00	0.00
8,220.00	0.00	0.00	8,141.88	-84.68	-891.03	182.94	0.00	0.00	0.00
8,235.00	0.00	0.00	8,156.88	-84.68	-891.03	182.94	0.00	0.00	0.00
8,250.00	0.00	0.00	8,171.88	-84.68	-891.03	182.94	0.00	0.00	0.00
8,265.00	0.00	0.00	8,186.88	-84.68	-891.03	182.94	0.00	0.00	0.00
8,280.00	0.00	0.00	8,201.88	-84.68	-891.03	182.94	0.00	0.00	0.00
8,295.00	0.00	0.00	8,216.88	-84.68	-891.03	182.94	0.00	0.00	0.00
8,310.00	0.00	0.00	8,231.88	-84.68	-891.03	182.94	0.00	0.00	0.00
8,325.00	0.00	0.00	8,246.88	-84.68	-891.03	182.94	0.00	0.00	0.00
8,340.00	0.00	0.00	8,261.88	-84.68	-891.03	182.94	0.00	0.00	0.00
8,355.00	0.00	0.00	8,276.88	-84.68	-891.03	182.94	0.00	0.00	0.00
8,370.00	0.00	0.00	8,291.88	-84.68	-891.03	182.94	0.00	0.00	0.00
8,385.00	0.00	0.00	8,306.88	-84.68	-891.03	182.94	0.00	0.00	0.00
8,400.00	0.00	0.00	8,321.88	-84.68	-891.03	182.94	0.00	0.00	0.00
8,415.00	0.00	0.00	8,336.88	-84.68	-891.03	182.94	0.00	0.00	0.00
8,430.00	0.00	0.00	8,351.88	-84.68	-891.03	182.94	0.00	0.00	0.00
8,434.66	0.00	0.00	8,356.54	-84.68	-891.03	182.94	0.00	0.00	0.00
8,445.00	1.24	179.92	8,366.88	-84.79	-891.03	183.06	12.00	12.00	0.00
8,460.00	3.04	179.92	8,381.87	-85.35	-891.03	183.61	12.00	12.00	0.00
8,475.00	4.84	179.92	8,396.83	-86.38	-891.03	184.64	12.00	12.00	0.00
8,490.00	6.64	179.92	8,411.76	-87.88	-891.03	186.13	12.00	12.00	0.00
8,505.00	8.44	179.92	8,426.63	-89.85	-891.02	188.08	12.00	12.00	0.00
8,520.00	10.24	179.92	8,441.43	-92.29	-891.02	190.50	12.00	12.00	0.00
8,535.00	12.04	179.92	8,456.14	-95.18	-891.01	193.38	12.00	12.00	0.00
8,550.00	13.84	179.92	8,470.76	-98.54	-891.01	196.72	12.00	12.00	0.00
8,565.00	15.64	179.92	8,485.27	-102.36	-891.00	200.51	12.00	12.00	0.00
8,580.00	17.44	179.92	8,499.65	-106.63	-891.00	204.76	12.00	12.00	0.00
8,595.00	19.24	179.92	8,513.88	-111.35	-890.99	209.45	12.00	12.00	0.00
8,610.00	21.04	179.92	8,527.97	-116.52	-890.98	214.58	12.00	12.00	0.00
8,625.00	22.84	179.92	8,541.88	-122.12	-890.98	220.15	12.00	12.00	0.00
8,640.00	24.64	179.92	8,555.61	-128.16	-890.97	226.15	12.00	12.00	0.00
8,655.00	26.44	179.92	8,569.14	-134.63	-890.96	232.57	12.00	12.00	0.00
8,670.00	28.24	179.92	8,582.47	-141.51	-890.95	239.42	12.00	12.00	0.00
8,685.00	30.04	179.92	8,595.57	-148.82	-890.94	246.68	12.00	12.00	0.00
8,700.00	31.84	179.92	8,608.43	-156.53	-890.93	254.34	12.00	12.00	0.00
8,715.00	33.64	179.92	8,621.05	-164.64	-890.91	262.40	12.00	12.00	0.00
8,730.00	35.44	179.92	8,633.40	-173.15	-890.90	270.85	12.00	12.00	0.00
8,745.00	37.24	179.92	8,645.49	-182.04	-890.89	279.69	12.00	12.00	0.00
8,760.00	39.04	179.92	8,657.28	-191.30	-890.88	288.89	12.00	12.00	0.00
8,775.00	40.84	179.92	8,668.78	-200.93	-890.86	298.46	12.00	12.00	0.00
8,790.00	42.64	179.92	8,679.98	-210.92	-890.85	308.38	12.00	12.00	0.00
8,805.00	44.44	179.92	8,690.85	-221.25	-890.83	318.65	12.00	12.00	0.00
8,820.00	46.24	179.92	8,701.39	-231.92	-890.82	329.25	12.00	12.00	0.00

ConocoPhillips

Planning Report

Database:	EDT 17 Permian Prod	Local Co-ordinate Reference:	Well _SWEET TEA FEDERAL COM 552H
Company:	DELAWARE BASIN WEST	TVD Reference:	GL @ 2920.00usft
Project:	ATLAS PROSPECT_NME	MD Reference:	GL @ 2920.00usft
Site:	SWEET TEA FED COM PROJECT	North Reference:	Grid
Well:	_SWEET TEA FEDERAL COM 552H	Survey Calculation Method:	Minimum Curvature
Wellbore:	OWB		
Design:	PWPO		

Planned Survey									
Measured Depth (usft)	Inclination (°)	Azimuth (°)	Vertical Depth (usft)	+N/-S (usft)	+E/-W (usft)	Vertical Section (usft)	Dogleg Rate (°/100usft)	Build Rate (°/100usft)	Turn Rate (°/100usft)
8,835.00	48.04	179.92	8,711.59	-242.91	-890.80	340.18	12.00	12.00	0.00
8,850.00	49.84	179.92	8,721.45	-254.22	-890.78	351.41	12.00	12.00	0.00
8,865.00	51.64	179.92	8,730.94	-265.84	-890.77	362.96	12.00	12.00	0.00
8,880.00	53.44	179.92	8,740.06	-277.74	-890.75	374.79	12.00	12.00	0.00
8,895.00	55.24	179.92	8,748.80	-289.93	-890.73	386.90	12.00	12.00	0.00
8,910.00	57.04	179.92	8,757.16	-302.39	-890.71	399.27	12.00	12.00	0.00
8,925.00	58.84	179.92	8,765.12	-315.10	-890.70	411.90	12.00	12.00	0.00
8,940.00	60.64	179.92	8,772.68	-328.05	-890.68	424.78	12.00	12.00	0.00
8,955.00	62.44	179.92	8,779.83	-341.24	-890.66	437.88	12.00	12.00	0.00
8,970.00	64.24	179.92	8,786.56	-354.64	-890.64	451.20	12.00	12.00	0.00
8,985.00	66.04	179.92	8,792.86	-368.25	-890.62	464.73	12.00	12.00	0.00
9,000.00	67.84	179.92	8,798.74	-382.06	-890.60	478.44	12.00	12.00	0.00
9,015.00	69.64	179.92	8,804.18	-396.03	-890.58	492.33	12.00	12.00	0.00
9,030.00	71.44	179.92	8,809.18	-410.18	-890.56	506.38	12.00	12.00	0.00
9,045.00	73.24	179.92	8,813.73	-424.47	-890.54	520.58	12.00	12.00	0.00
9,060.00	75.04	179.92	8,817.82	-438.90	-890.52	534.92	12.00	12.00	0.00
9,075.00	76.84	179.92	8,821.47	-453.45	-890.50	549.38	12.00	12.00	0.00
9,090.00	78.64	179.92	8,824.65	-468.10	-890.47	563.94	12.00	12.00	0.00
9,105.00	80.44	179.92	8,827.38	-482.85	-890.45	578.60	12.00	12.00	0.00
9,120.00	82.24	179.92	8,829.63	-497.68	-890.43	593.34	12.00	12.00	0.00
9,135.00	84.04	179.92	8,831.42	-512.58	-890.41	608.13	12.00	12.00	0.00
9,150.00	85.84	179.92	8,832.75	-527.52	-890.39	622.98	12.00	12.00	0.00
9,165.00	87.64	179.92	8,833.60	-542.49	-890.37	637.86	12.00	12.00	0.00
9,180.00	89.44	179.92	8,833.98	-557.49	-890.35	652.76	12.00	12.00	0.00
9,184.66	90.00	179.92	8,834.01	-562.14	-890.34	657.39	12.00	12.00	0.00
9,195.00	90.00	179.92	8,834.01	-572.49	-890.32	667.67	0.00	0.00	0.00
9,210.00	90.00	179.92	8,834.01	-587.49	-890.30	682.57	0.00	0.00	0.00
9,225.00	90.00	179.92	8,834.00	-602.49	-890.28	697.48	0.00	0.00	0.00
9,240.00	90.00	179.92	8,834.00	-617.49	-890.26	712.38	0.00	0.00	0.00
9,255.00	90.00	179.92	8,834.00	-632.49	-890.24	727.29	0.00	0.00	0.00
9,270.00	90.00	179.92	8,834.00	-647.49	-890.21	742.19	0.00	0.00	0.00
9,285.00	90.00	179.92	8,834.00	-662.49	-890.19	757.10	0.00	0.00	0.00
9,300.00	90.00	179.92	8,834.00	-677.49	-890.17	772.00	0.00	0.00	0.00
9,315.00	90.00	179.92	8,834.00	-692.49	-890.15	786.91	0.00	0.00	0.00
9,330.00	90.00	179.92	8,834.00	-707.49	-890.13	801.81	0.00	0.00	0.00
9,345.00	90.00	179.92	8,834.00	-722.49	-890.11	816.72	0.00	0.00	0.00
9,360.00	90.00	179.92	8,834.00	-737.49	-890.08	831.62	0.00	0.00	0.00
9,375.00	90.00	179.92	8,834.00	-752.49	-890.06	846.53	0.00	0.00	0.00
9,390.00	90.00	179.92	8,834.00	-767.49	-890.04	861.43	0.00	0.00	0.00
9,405.00	90.00	179.92	8,834.00	-782.49	-890.02	876.34	0.00	0.00	0.00
9,420.00	90.00	179.92	8,834.00	-797.49	-890.00	891.24	0.00	0.00	0.00
9,435.00	90.00	179.92	8,834.00	-812.49	-889.98	906.15	0.00	0.00	0.00
9,450.00	90.00	179.92	8,834.00	-827.49	-889.95	921.05	0.00	0.00	0.00
9,465.00	90.00	179.92	8,834.00	-842.49	-889.93	935.96	0.00	0.00	0.00
9,480.00	90.00	179.92	8,834.00	-857.49	-889.91	950.86	0.00	0.00	0.00
9,495.00	90.00	179.92	8,834.00	-872.49	-889.89	965.77	0.00	0.00	0.00
9,510.00	90.00	179.92	8,834.00	-887.49	-889.87	980.67	0.00	0.00	0.00
9,525.00	90.00	179.92	8,834.00	-902.49	-889.85	995.58	0.00	0.00	0.00
9,540.00	90.00	179.92	8,834.00	-917.49	-889.82	1,010.48	0.00	0.00	0.00
9,555.00	90.00	179.92	8,834.00	-932.49	-889.80	1,025.39	0.00	0.00	0.00
9,570.00	90.00	179.92	8,834.00	-947.49	-889.78	1,040.29	0.00	0.00	0.00
9,585.00	90.00	179.92	8,834.00	-962.49	-889.76	1,055.20	0.00	0.00	0.00
9,600.00	90.00	179.92	8,834.00	-977.49	-889.74	1,070.10	0.00	0.00	0.00
9,615.00	90.00	179.92	8,834.00	-992.49	-889.72	1,085.01	0.00	0.00	0.00

ConocoPhillips

Planning Report

Database:	EDT 17 Permian Prod	Local Co-ordinate Reference:	Well _SWEET TEA FEDERAL COM 552H
Company:	DELAWARE BASIN WEST	TVD Reference:	GL @ 2920.00usft
Project:	ATLAS PROSPECT_NME	MD Reference:	GL @ 2920.00usft
Site:	SWEET TEA FED COM PROJECT	North Reference:	Grid
Well:	_SWEET TEA FEDERAL COM 552H	Survey Calculation Method:	Minimum Curvature
Wellbore:	OWB		
Design:	PWPO		

Planned Survey										
Measured Depth (usft)	Inclination (°)	Azimuth (°)	Vertical Depth (usft)	+N/-S (usft)	+E/-W (usft)	Vertical Section (usft)	Dogleg Rate (°/100usft)	Build Rate (°/100usft)	Turn Rate (°/100usft)	
9,630.00	90.00	179.92	8,834.00	-1,007.49	-889.69	1,099.91	0.00	0.00	0.00	
9,645.00	90.00	179.92	8,834.00	-1,022.49	-889.67	1,114.82	0.00	0.00	0.00	
9,660.00	90.00	179.92	8,834.00	-1,037.49	-889.65	1,129.72	0.00	0.00	0.00	
9,675.00	90.00	179.92	8,834.00	-1,052.49	-889.63	1,144.63	0.00	0.00	0.00	
9,690.00	90.00	179.92	8,834.00	-1,067.49	-889.61	1,159.53	0.00	0.00	0.00	
9,705.00	90.00	179.92	8,834.00	-1,082.49	-889.58	1,174.44	0.00	0.00	0.00	
9,720.00	90.00	179.92	8,834.00	-1,097.49	-889.56	1,189.34	0.00	0.00	0.00	
9,735.00	90.00	179.92	8,834.00	-1,112.49	-889.54	1,204.25	0.00	0.00	0.00	
9,750.00	90.00	179.92	8,834.00	-1,127.49	-889.52	1,219.15	0.00	0.00	0.00	
9,765.00	90.00	179.92	8,834.00	-1,142.49	-889.50	1,234.06	0.00	0.00	0.00	
9,780.00	90.00	179.92	8,834.00	-1,157.49	-889.48	1,248.96	0.00	0.00	0.00	
9,795.00	90.00	179.92	8,834.00	-1,172.49	-889.45	1,263.87	0.00	0.00	0.00	
9,810.00	90.00	179.92	8,834.00	-1,187.49	-889.43	1,278.77	0.00	0.00	0.00	
9,825.00	90.00	179.92	8,834.00	-1,202.49	-889.41	1,293.68	0.00	0.00	0.00	
9,840.00	90.00	179.92	8,834.00	-1,217.49	-889.39	1,308.58	0.00	0.00	0.00	
9,855.00	90.00	179.92	8,834.00	-1,232.49	-889.37	1,323.49	0.00	0.00	0.00	
9,870.00	90.00	179.92	8,834.00	-1,247.49	-889.35	1,338.39	0.00	0.00	0.00	
9,885.00	90.00	179.92	8,834.00	-1,262.49	-889.32	1,353.30	0.00	0.00	0.00	
9,900.00	90.00	179.92	8,834.00	-1,277.49	-889.30	1,368.20	0.00	0.00	0.00	
9,915.00	90.00	179.92	8,834.00	-1,292.49	-889.28	1,383.11	0.00	0.00	0.00	
9,930.00	90.00	179.92	8,834.00	-1,307.49	-889.26	1,398.02	0.00	0.00	0.00	
9,945.00	90.00	179.92	8,834.00	-1,322.49	-889.24	1,412.92	0.00	0.00	0.00	
9,960.00	90.00	179.92	8,834.00	-1,337.49	-889.22	1,427.83	0.00	0.00	0.00	
9,975.00	90.00	179.92	8,834.00	-1,352.49	-889.19	1,442.73	0.00	0.00	0.00	
9,990.00	90.00	179.92	8,834.00	-1,367.49	-889.17	1,457.64	0.00	0.00	0.00	
10,005.00	90.00	179.92	8,834.00	-1,382.48	-889.15	1,472.54	0.00	0.00	0.00	
10,020.00	90.00	179.92	8,834.00	-1,397.48	-889.13	1,487.45	0.00	0.00	0.00	
10,035.00	90.00	179.92	8,834.00	-1,412.48	-889.11	1,502.35	0.00	0.00	0.00	
10,050.00	90.00	179.92	8,834.00	-1,427.48	-889.09	1,517.26	0.00	0.00	0.00	
10,065.00	90.00	179.92	8,834.00	-1,442.48	-889.06	1,532.16	0.00	0.00	0.00	
10,080.00	90.00	179.92	8,834.00	-1,457.48	-889.04	1,547.07	0.00	0.00	0.00	
10,095.00	90.00	179.92	8,834.00	-1,472.48	-889.02	1,561.97	0.00	0.00	0.00	
10,110.00	90.00	179.92	8,834.00	-1,487.48	-889.00	1,576.88	0.00	0.00	0.00	
10,125.00	90.00	179.92	8,834.00	-1,502.48	-888.98	1,591.78	0.00	0.00	0.00	
10,140.00	90.00	179.92	8,834.00	-1,517.48	-888.95	1,606.69	0.00	0.00	0.00	
10,155.00	90.00	179.92	8,834.00	-1,532.48	-888.93	1,621.59	0.00	0.00	0.00	
10,170.00	90.00	179.92	8,834.00	-1,547.48	-888.91	1,636.50	0.00	0.00	0.00	
10,185.00	90.00	179.92	8,834.00	-1,562.48	-888.89	1,651.40	0.00	0.00	0.00	
10,200.00	90.00	179.92	8,834.00	-1,577.48	-888.87	1,666.31	0.00	0.00	0.00	
10,215.00	90.00	179.92	8,834.00	-1,592.48	-888.85	1,681.21	0.00	0.00	0.00	
10,230.00	90.00	179.92	8,834.00	-1,607.48	-888.82	1,696.12	0.00	0.00	0.00	
10,245.00	90.00	179.92	8,834.00	-1,622.48	-888.80	1,711.02	0.00	0.00	0.00	
10,260.00	90.00	179.92	8,834.00	-1,637.48	-888.78	1,725.93	0.00	0.00	0.00	
10,275.00	90.00	179.92	8,834.00	-1,652.48	-888.76	1,740.83	0.00	0.00	0.00	
10,290.00	90.00	179.92	8,834.00	-1,667.48	-888.74	1,755.74	0.00	0.00	0.00	
10,305.00	90.00	179.92	8,834.00	-1,682.48	-888.72	1,770.64	0.00	0.00	0.00	
10,320.00	90.00	179.92	8,834.00	-1,697.48	-888.69	1,785.55	0.00	0.00	0.00	
10,335.00	90.00	179.92	8,834.00	-1,712.48	-888.67	1,800.45	0.00	0.00	0.00	
10,350.00	90.00	179.92	8,834.00	-1,727.48	-888.65	1,815.36	0.00	0.00	0.00	
10,365.00	90.00	179.92	8,834.00	-1,742.48	-888.63	1,830.26	0.00	0.00	0.00	
10,380.00	90.00	179.92	8,834.00	-1,757.48	-888.61	1,845.17	0.00	0.00	0.00	
10,395.00	90.00	179.92	8,834.00	-1,772.48	-888.59	1,860.07	0.00	0.00	0.00	
10,410.00	90.00	179.92	8,834.00	-1,787.48	-888.56	1,874.98	0.00	0.00	0.00	
10,425.00	90.00	179.92	8,834.00	-1,802.48	-888.54	1,889.88	0.00	0.00	0.00	

ConocoPhillips

Planning Report

Database:	EDT 17 Permian Prod	Local Co-ordinate Reference:	Well _SWEET TEA FEDERAL COM 552H
Company:	DELAWARE BASIN WEST	TVD Reference:	GL @ 2920.00usft
Project:	ATLAS PROSPECT_NME	MD Reference:	GL @ 2920.00usft
Site:	SWEET TEA FED COM PROJECT	North Reference:	Grid
Well:	_SWEET TEA FEDERAL COM 552H	Survey Calculation Method:	Minimum Curvature
Wellbore:	OWB		
Design:	PWP0		

Planned Survey									
Measured Depth (usft)	Inclination (°)	Azimuth (°)	Vertical Depth (usft)	+N/-S (usft)	+E/-W (usft)	Vertical Section (usft)	Dogleg Rate (°/100usft)	Build Rate (°/100usft)	Turn Rate (°/100usft)
10,440.00	90.00	179.92	8,834.00	-1,817.48	-888.52	1,904.79	0.00	0.00	0.00
10,455.00	90.00	179.92	8,834.00	-1,832.48	-888.50	1,919.69	0.00	0.00	0.00
10,470.00	90.00	179.92	8,834.00	-1,847.48	-888.48	1,934.60	0.00	0.00	0.00
10,485.00	90.00	179.92	8,834.00	-1,862.48	-888.45	1,949.50	0.00	0.00	0.00
10,500.00	90.00	179.92	8,834.00	-1,877.48	-888.43	1,964.41	0.00	0.00	0.00
10,515.00	90.00	179.92	8,834.00	-1,892.48	-888.41	1,979.31	0.00	0.00	0.00
10,530.00	90.00	179.92	8,834.00	-1,907.48	-888.39	1,994.22	0.00	0.00	0.00
10,545.00	90.00	179.92	8,834.00	-1,922.48	-888.37	2,009.12	0.00	0.00	0.00
10,560.00	90.00	179.92	8,834.00	-1,937.48	-888.35	2,024.03	0.00	0.00	0.00
10,575.00	90.00	179.92	8,834.00	-1,952.48	-888.32	2,038.93	0.00	0.00	0.00
10,590.00	90.00	179.92	8,834.00	-1,967.48	-888.30	2,053.84	0.00	0.00	0.00
10,605.00	90.00	179.92	8,834.00	-1,982.48	-888.28	2,068.74	0.00	0.00	0.00
10,620.00	90.00	179.92	8,834.00	-1,997.48	-888.26	2,083.65	0.00	0.00	0.00
10,635.00	90.00	179.92	8,834.00	-2,012.48	-888.24	2,098.55	0.00	0.00	0.00
10,650.00	90.00	179.92	8,834.00	-2,027.48	-888.22	2,113.46	0.00	0.00	0.00
10,665.00	90.00	179.92	8,834.00	-2,042.48	-888.19	2,128.37	0.00	0.00	0.00
10,680.00	90.00	179.92	8,834.00	-2,057.48	-888.17	2,143.27	0.00	0.00	0.00
10,695.00	90.00	179.92	8,834.00	-2,072.48	-888.15	2,158.18	0.00	0.00	0.00
10,710.00	90.00	179.92	8,834.00	-2,087.48	-888.13	2,173.08	0.00	0.00	0.00
10,725.00	90.00	179.92	8,834.00	-2,102.48	-888.11	2,187.99	0.00	0.00	0.00
10,740.00	90.00	179.92	8,834.00	-2,117.48	-888.09	2,202.89	0.00	0.00	0.00
10,755.00	90.00	179.92	8,834.00	-2,132.48	-888.06	2,217.80	0.00	0.00	0.00
10,770.00	90.00	179.92	8,834.00	-2,147.48	-888.04	2,232.70	0.00	0.00	0.00
10,785.00	90.00	179.92	8,834.00	-2,162.48	-888.02	2,247.61	0.00	0.00	0.00
10,800.00	90.00	179.92	8,834.00	-2,177.48	-888.00	2,262.51	0.00	0.00	0.00
10,815.00	90.00	179.92	8,834.00	-2,192.48	-887.98	2,277.42	0.00	0.00	0.00
10,830.00	90.00	179.92	8,834.00	-2,207.48	-887.96	2,292.32	0.00	0.00	0.00
10,845.00	90.00	179.92	8,834.00	-2,222.48	-887.93	2,307.23	0.00	0.00	0.00
10,860.00	90.00	179.92	8,834.00	-2,237.48	-887.91	2,322.13	0.00	0.00	0.00
10,875.00	90.00	179.92	8,834.00	-2,252.48	-887.89	2,337.04	0.00	0.00	0.00
10,890.00	90.00	179.92	8,834.00	-2,267.48	-887.87	2,351.94	0.00	0.00	0.00
10,905.00	90.00	179.92	8,834.00	-2,282.48	-887.85	2,366.85	0.00	0.00	0.00
10,920.00	90.00	179.92	8,834.00	-2,297.48	-887.82	2,381.75	0.00	0.00	0.00
10,935.00	90.00	179.92	8,834.00	-2,312.48	-887.80	2,396.66	0.00	0.00	0.00
10,950.00	90.00	179.92	8,834.00	-2,327.48	-887.78	2,411.56	0.00	0.00	0.00
10,965.00	90.00	179.92	8,834.00	-2,342.48	-887.76	2,426.47	0.00	0.00	0.00
10,980.00	90.00	179.92	8,834.00	-2,357.48	-887.74	2,441.37	0.00	0.00	0.00
10,995.00	90.00	179.92	8,834.00	-2,372.48	-887.72	2,456.28	0.00	0.00	0.00
11,010.00	90.00	179.92	8,834.00	-2,387.48	-887.69	2,471.18	0.00	0.00	0.00
11,025.00	90.00	179.92	8,834.00	-2,402.48	-887.67	2,486.09	0.00	0.00	0.00
11,040.00	90.00	179.92	8,834.00	-2,417.48	-887.65	2,500.99	0.00	0.00	0.00
11,055.00	90.00	179.92	8,834.00	-2,432.48	-887.63	2,515.90	0.00	0.00	0.00
11,070.00	90.00	179.92	8,834.00	-2,447.48	-887.61	2,530.80	0.00	0.00	0.00
11,085.00	90.00	179.92	8,834.00	-2,462.48	-887.59	2,545.71	0.00	0.00	0.00
11,100.00	90.00	179.92	8,834.00	-2,477.48	-887.56	2,560.61	0.00	0.00	0.00
11,115.00	90.00	179.92	8,834.00	-2,492.48	-887.54	2,575.52	0.00	0.00	0.00
11,130.00	90.00	179.92	8,834.00	-2,507.48	-887.52	2,590.42	0.00	0.00	0.00
11,145.00	90.00	179.92	8,834.00	-2,522.48	-887.50	2,605.33	0.00	0.00	0.00
11,160.00	90.00	179.92	8,834.00	-2,537.48	-887.48	2,620.23	0.00	0.00	0.00
11,175.00	90.00	179.92	8,834.00	-2,552.48	-887.46	2,635.14	0.00	0.00	0.00
11,190.00	90.00	179.92	8,834.00	-2,567.48	-887.43	2,650.04	0.00	0.00	0.00
11,205.00	90.00	179.92	8,834.00	-2,582.48	-887.41	2,664.95	0.00	0.00	0.00
11,220.00	90.00	179.92	8,834.00	-2,597.48	-887.39	2,679.85	0.00	0.00	0.00
11,235.00	90.00	179.92	8,834.00	-2,612.48	-887.37	2,694.76	0.00	0.00	0.00

ConocoPhillips

Planning Report

Database:	EDT 17 Permian Prod	Local Co-ordinate Reference:	Well _SWEET TEA FEDERAL COM 552H
Company:	DELAWARE BASIN WEST	TVD Reference:	GL @ 2920.00usft
Project:	ATLAS PROSPECT_NME	MD Reference:	GL @ 2920.00usft
Site:	SWEET TEA FED COM PROJECT	North Reference:	Grid
Well:	_SWEET TEA FEDERAL COM 552H	Survey Calculation Method:	Minimum Curvature
Wellbore:	OWB		
Design:	PWPO		

Planned Survey									
Measured Depth (usft)	Inclination (°)	Azimuth (°)	Vertical Depth (usft)	+N/-S (usft)	+E/-W (usft)	Vertical Section (usft)	Dogleg Rate (°/100usft)	Build Rate (°/100usft)	Turn Rate (°/100usft)
11,250.00	90.00	179.92	8,834.00	-2,627.48	-887.35	2,709.66	0.00	0.00	0.00
11,265.00	90.00	179.92	8,834.00	-2,642.48	-887.33	2,724.57	0.00	0.00	0.00
11,280.00	90.00	179.92	8,834.00	-2,657.48	-887.30	2,739.47	0.00	0.00	0.00
11,295.00	90.00	179.92	8,834.00	-2,672.48	-887.28	2,754.38	0.00	0.00	0.00
11,310.00	90.00	179.92	8,834.00	-2,687.48	-887.26	2,769.28	0.00	0.00	0.00
11,325.00	90.00	179.92	8,834.00	-2,702.48	-887.24	2,784.19	0.00	0.00	0.00
11,340.00	90.00	179.92	8,834.00	-2,717.48	-887.22	2,799.09	0.00	0.00	0.00
11,355.00	90.00	179.92	8,834.00	-2,732.48	-887.19	2,814.00	0.00	0.00	0.00
11,370.00	90.00	179.92	8,834.00	-2,747.48	-887.17	2,828.90	0.00	0.00	0.00
11,385.00	90.00	179.92	8,834.00	-2,762.48	-887.15	2,843.81	0.00	0.00	0.00
11,400.00	90.00	179.92	8,834.00	-2,777.48	-887.13	2,858.72	0.00	0.00	0.00
11,415.00	90.00	179.92	8,834.00	-2,792.48	-887.11	2,873.62	0.00	0.00	0.00
11,430.00	90.00	179.92	8,834.00	-2,807.48	-887.09	2,888.53	0.00	0.00	0.00
11,445.00	90.00	179.92	8,834.00	-2,822.48	-887.06	2,903.43	0.00	0.00	0.00
11,460.00	90.00	179.92	8,834.00	-2,837.48	-887.04	2,918.34	0.00	0.00	0.00
11,475.00	90.00	179.92	8,834.00	-2,852.48	-887.02	2,933.24	0.00	0.00	0.00
11,490.00	90.00	179.92	8,834.00	-2,867.48	-887.00	2,948.15	0.00	0.00	0.00
11,505.00	90.00	179.92	8,834.00	-2,882.48	-886.98	2,963.05	0.00	0.00	0.00
11,520.00	90.00	179.92	8,834.00	-2,897.48	-886.96	2,977.96	0.00	0.00	0.00
11,535.00	90.00	179.92	8,834.00	-2,912.48	-886.93	2,992.86	0.00	0.00	0.00
11,550.00	90.00	179.92	8,834.00	-2,927.48	-886.91	3,007.77	0.00	0.00	0.00
11,565.00	90.00	179.92	8,834.00	-2,942.48	-886.89	3,022.67	0.00	0.00	0.00
11,580.00	90.00	179.92	8,834.00	-2,957.48	-886.87	3,037.58	0.00	0.00	0.00
11,595.00	90.00	179.92	8,834.00	-2,972.48	-886.85	3,052.48	0.00	0.00	0.00
11,610.00	90.00	179.92	8,834.00	-2,987.48	-886.83	3,067.39	0.00	0.00	0.00
11,625.00	90.00	179.92	8,834.00	-3,002.48	-886.80	3,082.29	0.00	0.00	0.00
11,640.00	90.00	179.92	8,834.00	-3,017.48	-886.78	3,097.20	0.00	0.00	0.00
11,655.00	90.00	179.92	8,834.00	-3,032.48	-886.76	3,112.10	0.00	0.00	0.00
11,670.00	90.00	179.92	8,834.00	-3,047.48	-886.74	3,127.01	0.00	0.00	0.00
11,685.00	90.00	179.92	8,834.00	-3,062.48	-886.72	3,141.91	0.00	0.00	0.00
11,700.00	90.00	179.92	8,834.00	-3,077.48	-886.70	3,156.82	0.00	0.00	0.00
11,715.00	90.00	179.92	8,834.00	-3,092.48	-886.67	3,171.72	0.00	0.00	0.00
11,730.00	90.00	179.92	8,834.00	-3,107.48	-886.65	3,186.63	0.00	0.00	0.00
11,745.00	90.00	179.92	8,834.00	-3,122.48	-886.63	3,201.53	0.00	0.00	0.00
11,760.00	90.00	179.92	8,834.00	-3,137.48	-886.61	3,216.44	0.00	0.00	0.00
11,775.00	90.00	179.92	8,834.00	-3,152.48	-886.59	3,231.34	0.00	0.00	0.00
11,790.00	90.00	179.92	8,834.00	-3,167.48	-886.56	3,246.25	0.00	0.00	0.00
11,805.00	90.00	179.92	8,834.00	-3,182.48	-886.54	3,261.15	0.00	0.00	0.00
11,820.00	90.00	179.92	8,834.00	-3,197.48	-886.52	3,276.06	0.00	0.00	0.00
11,835.00	90.00	179.92	8,834.00	-3,212.48	-886.50	3,290.96	0.00	0.00	0.00
11,850.00	90.00	179.92	8,834.00	-3,227.48	-886.48	3,305.87	0.00	0.00	0.00
11,865.00	90.00	179.92	8,834.00	-3,242.48	-886.46	3,320.77	0.00	0.00	0.00
11,880.00	90.00	179.92	8,834.00	-3,257.48	-886.43	3,335.68	0.00	0.00	0.00
11,895.00	90.00	179.92	8,834.00	-3,272.48	-886.41	3,350.58	0.00	0.00	0.00
11,910.00	90.00	179.92	8,834.00	-3,287.48	-886.39	3,365.49	0.00	0.00	0.00
11,925.00	90.00	179.92	8,834.00	-3,302.48	-886.37	3,380.39	0.00	0.00	0.00
11,940.00	90.00	179.92	8,834.00	-3,317.48	-886.35	3,395.30	0.00	0.00	0.00
11,955.00	90.00	179.92	8,834.00	-3,332.48	-886.33	3,410.20	0.00	0.00	0.00
11,970.00	90.00	179.92	8,834.00	-3,347.48	-886.30	3,425.11	0.00	0.00	0.00
11,985.00	90.00	179.92	8,834.00	-3,362.48	-886.28	3,440.01	0.00	0.00	0.00
12,000.00	90.00	179.92	8,834.00	-3,377.48	-886.26	3,454.92	0.00	0.00	0.00
12,015.00	90.00	179.92	8,834.00	-3,392.48	-886.24	3,469.82	0.00	0.00	0.00
12,030.00	90.00	179.92	8,834.00	-3,407.48	-886.22	3,484.73	0.00	0.00	0.00
12,045.00	90.00	179.92	8,834.00	-3,422.48	-886.20	3,499.63	0.00	0.00	0.00

ConocoPhillips

Planning Report

Database:	EDT 17 Permian Prod	Local Co-ordinate Reference:	Well _SWEET TEA FEDERAL COM 552H
Company:	DELAWARE BASIN WEST	TVD Reference:	GL @ 2920.00usft
Project:	ATLAS PROSPECT_NME	MD Reference:	GL @ 2920.00usft
Site:	SWEET TEA FED COM PROJECT	North Reference:	Grid
Well:	_SWEET TEA FEDERAL COM 552H	Survey Calculation Method:	Minimum Curvature
Wellbore:	OWB		
Design:	PWP0		

Planned Survey										
Measured Depth (usft)	Inclination (°)	Azimuth (°)	Vertical Depth (usft)	+N/-S (usft)	+E/-W (usft)	Vertical Section (usft)	Dogleg Rate (°/100usft)	Build Rate (°/100usft)	Turn Rate (°/100usft)	
12,060.00	90.00	179.92	8,834.00	-3,437.48	-886.17	3,514.54	0.00	0.00	0.00	
12,075.00	90.00	179.92	8,834.00	-3,452.48	-886.15	3,529.44	0.00	0.00	0.00	
12,090.00	90.00	179.92	8,834.00	-3,467.48	-886.13	3,544.35	0.00	0.00	0.00	
12,105.00	90.00	179.92	8,834.00	-3,482.48	-886.11	3,559.25	0.00	0.00	0.00	
12,120.00	90.00	179.92	8,834.00	-3,497.48	-886.09	3,574.16	0.00	0.00	0.00	
12,135.00	90.00	179.92	8,834.00	-3,512.48	-886.06	3,589.07	0.00	0.00	0.00	
12,150.00	90.00	179.92	8,834.00	-3,527.48	-886.04	3,603.97	0.00	0.00	0.00	
12,165.00	90.00	179.92	8,834.00	-3,542.48	-886.02	3,618.88	0.00	0.00	0.00	
12,180.00	90.00	179.92	8,834.00	-3,557.48	-886.00	3,633.78	0.00	0.00	0.00	
12,195.00	90.00	179.92	8,834.00	-3,572.48	-885.98	3,648.69	0.00	0.00	0.00	
12,210.00	90.00	179.92	8,834.00	-3,587.48	-885.96	3,663.59	0.00	0.00	0.00	
12,225.00	90.00	179.92	8,834.00	-3,602.48	-885.93	3,678.50	0.00	0.00	0.00	
12,240.00	90.00	179.92	8,834.00	-3,617.48	-885.91	3,693.40	0.00	0.00	0.00	
12,255.00	90.00	179.92	8,834.00	-3,632.48	-885.89	3,708.31	0.00	0.00	0.00	
12,270.00	90.00	179.92	8,834.00	-3,647.48	-885.87	3,723.21	0.00	0.00	0.00	
12,285.00	90.00	179.92	8,834.00	-3,662.48	-885.85	3,738.12	0.00	0.00	0.00	
12,300.00	90.00	179.92	8,834.00	-3,677.48	-885.83	3,753.02	0.00	0.00	0.00	
12,315.00	90.00	179.92	8,834.00	-3,692.48	-885.80	3,767.93	0.00	0.00	0.00	
12,330.00	90.00	179.92	8,834.00	-3,707.48	-885.78	3,782.83	0.00	0.00	0.00	
12,345.00	90.00	179.92	8,834.00	-3,722.48	-885.76	3,797.74	0.00	0.00	0.00	
12,360.00	90.00	179.92	8,834.00	-3,737.48	-885.74	3,812.64	0.00	0.00	0.00	
12,375.00	90.00	179.92	8,834.00	-3,752.48	-885.72	3,827.55	0.00	0.00	0.00	
12,390.00	90.00	179.92	8,834.00	-3,767.48	-885.70	3,842.45	0.00	0.00	0.00	
12,405.00	90.00	179.92	8,834.00	-3,782.48	-885.67	3,857.36	0.00	0.00	0.00	
12,420.00	90.00	179.92	8,834.00	-3,797.48	-885.65	3,872.26	0.00	0.00	0.00	
12,435.00	90.00	179.92	8,834.00	-3,812.48	-885.63	3,887.17	0.00	0.00	0.00	
12,450.00	90.00	179.92	8,834.00	-3,827.48	-885.61	3,902.07	0.00	0.00	0.00	
12,465.00	90.00	179.92	8,834.00	-3,842.48	-885.59	3,916.98	0.00	0.00	0.00	
12,480.00	90.00	179.92	8,834.00	-3,857.48	-885.57	3,931.88	0.00	0.00	0.00	
12,495.00	90.00	179.92	8,834.00	-3,872.48	-885.54	3,946.79	0.00	0.00	0.00	
12,510.00	90.00	179.92	8,834.00	-3,887.48	-885.52	3,961.69	0.00	0.00	0.00	
12,525.00	90.00	179.92	8,834.00	-3,902.48	-885.50	3,976.60	0.00	0.00	0.00	
12,540.00	90.00	179.92	8,834.00	-3,917.48	-885.48	3,991.50	0.00	0.00	0.00	
12,555.00	90.00	179.92	8,834.00	-3,932.48	-885.46	4,006.41	0.00	0.00	0.00	
12,570.00	90.00	179.92	8,834.00	-3,947.48	-885.43	4,021.31	0.00	0.00	0.00	
12,585.00	90.00	179.92	8,834.00	-3,962.48	-885.41	4,036.22	0.00	0.00	0.00	
12,600.00	90.00	179.92	8,834.00	-3,977.48	-885.39	4,051.12	0.00	0.00	0.00	
12,615.00	90.00	179.92	8,834.00	-3,992.48	-885.37	4,066.03	0.00	0.00	0.00	
12,630.00	90.00	179.92	8,834.00	-4,007.48	-885.35	4,080.93	0.00	0.00	0.00	
12,645.00	90.00	179.92	8,834.00	-4,022.48	-885.33	4,095.84	0.00	0.00	0.00	
12,660.00	90.00	179.92	8,834.00	-4,037.48	-885.30	4,110.74	0.00	0.00	0.00	
12,675.00	90.00	179.92	8,834.00	-4,052.48	-885.28	4,125.65	0.00	0.00	0.00	
12,690.00	90.00	179.92	8,834.00	-4,067.48	-885.26	4,140.55	0.00	0.00	0.00	
12,705.00	90.00	179.92	8,834.00	-4,082.48	-885.24	4,155.46	0.00	0.00	0.00	
12,720.00	90.00	179.92	8,834.00	-4,097.48	-885.22	4,170.36	0.00	0.00	0.00	
12,735.00	90.00	179.92	8,834.00	-4,112.48	-885.20	4,185.27	0.00	0.00	0.00	
12,750.00	90.00	179.92	8,834.00	-4,127.48	-885.17	4,200.17	0.00	0.00	0.00	
12,765.00	90.00	179.92	8,834.00	-4,142.48	-885.15	4,215.08	0.00	0.00	0.00	
12,780.00	90.00	179.92	8,834.00	-4,157.48	-885.13	4,229.98	0.00	0.00	0.00	
12,795.00	90.00	179.92	8,834.00	-4,172.48	-885.11	4,244.89	0.00	0.00	0.00	
12,810.00	90.00	179.92	8,834.00	-4,187.48	-885.09	4,259.79	0.00	0.00	0.00	
12,825.00	90.00	179.92	8,834.00	-4,202.48	-885.07	4,274.70	0.00	0.00	0.00	
12,840.00	90.00	179.92	8,834.00	-4,217.48	-885.04	4,289.61	0.00	0.00	0.00	
12,855.00	90.00	179.92	8,834.00	-4,232.48	-885.02	4,304.51	0.00	0.00	0.00	

ConocoPhillips

Planning Report

Database:	EDT 17 Permian Prod	Local Co-ordinate Reference:	Well _SWEET TEA FEDERAL COM 552H
Company:	DELAWARE BASIN WEST	TVD Reference:	GL @ 2920.00usft
Project:	ATLAS PROSPECT_NME	MD Reference:	GL @ 2920.00usft
Site:	SWEET TEA FED COM PROJECT	North Reference:	Grid
Well:	_SWEET TEA FEDERAL COM 552H	Survey Calculation Method:	Minimum Curvature
Wellbore:	OWB		
Design:	PWP0		

Planned Survey									
Measured Depth (usft)	Inclination (°)	Azimuth (°)	Vertical Depth (usft)	+N/-S (usft)	+E/-W (usft)	Vertical Section (usft)	Dogleg Rate (°/100usft)	Build Rate (°/100usft)	Turn Rate (°/100usft)
12,870.00	90.00	179.92	8,834.00	-4,247.48	-885.00	4,319.42	0.00	0.00	0.00
12,885.00	90.00	179.92	8,834.00	-4,262.48	-884.98	4,334.32	0.00	0.00	0.00
12,900.00	90.00	179.92	8,834.00	-4,277.48	-884.96	4,349.23	0.00	0.00	0.00
12,915.00	90.00	179.92	8,834.00	-4,292.48	-884.94	4,364.13	0.00	0.00	0.00
12,930.00	90.00	179.92	8,834.00	-4,307.48	-884.91	4,379.04	0.00	0.00	0.00
12,945.00	90.00	179.92	8,834.00	-4,322.48	-884.89	4,393.94	0.00	0.00	0.00
12,960.00	90.00	179.92	8,834.00	-4,337.48	-884.87	4,408.85	0.00	0.00	0.00
12,975.00	90.00	179.92	8,834.00	-4,352.48	-884.85	4,423.75	0.00	0.00	0.00
12,990.00	90.00	179.92	8,834.00	-4,367.48	-884.83	4,438.66	0.00	0.00	0.00
13,005.00	90.00	179.92	8,834.00	-4,382.48	-884.80	4,453.56	0.00	0.00	0.00
13,020.00	90.00	179.92	8,834.00	-4,397.48	-884.78	4,468.47	0.00	0.00	0.00
13,035.00	90.00	179.92	8,834.00	-4,412.48	-884.76	4,483.37	0.00	0.00	0.00
13,050.00	90.00	179.92	8,834.00	-4,427.48	-884.74	4,498.28	0.00	0.00	0.00
13,065.00	90.00	179.92	8,834.00	-4,442.48	-884.72	4,513.18	0.00	0.00	0.00
13,080.00	90.00	179.92	8,834.00	-4,457.48	-884.70	4,528.09	0.00	0.00	0.00
13,095.00	90.00	179.92	8,834.00	-4,472.48	-884.67	4,542.99	0.00	0.00	0.00
13,110.00	90.00	179.92	8,834.00	-4,487.48	-884.65	4,557.90	0.00	0.00	0.00
13,125.00	90.00	179.92	8,834.00	-4,502.48	-884.63	4,572.80	0.00	0.00	0.00
13,140.00	90.00	179.92	8,834.00	-4,517.48	-884.61	4,587.71	0.00	0.00	0.00
13,155.00	90.00	179.92	8,834.00	-4,532.48	-884.59	4,602.61	0.00	0.00	0.00
13,170.00	90.00	179.92	8,834.00	-4,547.48	-884.57	4,617.52	0.00	0.00	0.00
13,185.00	90.00	179.92	8,834.00	-4,562.48	-884.54	4,632.42	0.00	0.00	0.00
13,200.00	90.00	179.92	8,834.00	-4,577.48	-884.52	4,647.33	0.00	0.00	0.00
13,215.00	90.00	179.92	8,834.00	-4,592.48	-884.50	4,662.23	0.00	0.00	0.00
13,230.00	90.00	179.92	8,834.00	-4,607.48	-884.48	4,677.14	0.00	0.00	0.00
13,245.00	90.00	179.92	8,834.00	-4,622.48	-884.46	4,692.04	0.00	0.00	0.00
13,260.00	90.00	179.92	8,834.00	-4,637.48	-884.44	4,706.95	0.00	0.00	0.00
13,275.00	90.00	179.92	8,834.00	-4,652.48	-884.41	4,721.85	0.00	0.00	0.00
13,290.00	90.00	179.92	8,834.00	-4,667.48	-884.39	4,736.76	0.00	0.00	0.00
13,305.00	90.00	179.92	8,834.00	-4,682.48	-884.37	4,751.66	0.00	0.00	0.00
13,320.00	90.00	179.92	8,834.00	-4,697.48	-884.35	4,766.57	0.00	0.00	0.00
13,335.00	90.00	179.92	8,834.00	-4,712.48	-884.33	4,781.47	0.00	0.00	0.00
13,350.00	90.00	179.92	8,834.00	-4,727.48	-884.31	4,796.38	0.00	0.00	0.00
13,365.00	90.00	179.92	8,834.00	-4,742.48	-884.28	4,811.28	0.00	0.00	0.00
13,380.00	90.00	179.92	8,834.00	-4,757.48	-884.26	4,826.19	0.00	0.00	0.00
13,395.00	90.00	179.92	8,834.00	-4,772.48	-884.24	4,841.09	0.00	0.00	0.00
13,410.00	90.00	179.92	8,834.00	-4,787.48	-884.22	4,856.00	0.00	0.00	0.00
13,425.00	90.00	179.92	8,834.00	-4,802.48	-884.20	4,870.90	0.00	0.00	0.00
13,440.00	90.00	179.92	8,834.00	-4,817.48	-884.17	4,885.81	0.00	0.00	0.00
13,455.00	90.00	179.92	8,834.00	-4,832.48	-884.15	4,900.71	0.00	0.00	0.00
13,470.00	90.00	179.92	8,834.00	-4,847.48	-884.13	4,915.62	0.00	0.00	0.00
13,485.00	90.00	179.92	8,834.00	-4,862.48	-884.11	4,930.52	0.00	0.00	0.00
13,500.00	90.00	179.92	8,834.00	-4,877.48	-884.09	4,945.43	0.00	0.00	0.00
13,515.00	90.00	179.92	8,834.00	-4,892.48	-884.07	4,960.33	0.00	0.00	0.00
13,530.00	90.00	179.92	8,834.00	-4,907.48	-884.04	4,975.24	0.00	0.00	0.00
13,545.00	90.00	179.92	8,834.00	-4,922.48	-884.02	4,990.14	0.00	0.00	0.00
13,560.00	90.00	179.92	8,834.00	-4,937.48	-884.00	5,005.05	0.00	0.00	0.00
13,575.00	90.00	179.92	8,834.00	-4,952.48	-883.98	5,019.96	0.00	0.00	0.00
13,590.00	90.00	179.92	8,834.00	-4,967.48	-883.96	5,034.86	0.00	0.00	0.00
13,605.00	90.00	179.92	8,834.00	-4,982.48	-883.94	5,049.77	0.00	0.00	0.00
13,620.00	90.00	179.92	8,834.00	-4,997.48	-883.91	5,064.67	0.00	0.00	0.00
13,635.00	90.00	179.92	8,834.00	-5,012.48	-883.89	5,079.58	0.00	0.00	0.00
13,650.00	90.00	179.92	8,834.00	-5,027.48	-883.87	5,094.48	0.00	0.00	0.00
13,665.00	90.00	179.92	8,834.00	-5,042.48	-883.85	5,109.39	0.00	0.00	0.00

ConocoPhillips

Planning Report

Database:	EDT 17 Permian Prod	Local Co-ordinate Reference:	Well _SWEET TEA FEDERAL COM 552H
Company:	DELAWARE BASIN WEST	TVD Reference:	GL @ 2920.00usft
Project:	ATLAS PROSPECT_NME	MD Reference:	GL @ 2920.00usft
Site:	SWEET TEA FED COM PROJECT	North Reference:	Grid
Well:	_SWEET TEA FEDERAL COM 552H	Survey Calculation Method:	Minimum Curvature
Wellbore:	OWB		
Design:	PWP0		

Planned Survey										
Measured Depth (usft)	Inclination (°)	Azimuth (°)	Vertical Depth (usft)	+N/-S (usft)	+E/-W (usft)	Vertical Section (usft)	Dogleg Rate (°/100usft)	Build Rate (°/100usft)	Turn Rate (°/100usft)	
13,680.00	90.00	179.92	8,834.00	-5,057.48	-883.83	5,124.29	0.00	0.00	0.00	
13,695.00	90.00	179.92	8,834.00	-5,072.48	-883.81	5,139.20	0.00	0.00	0.00	
13,710.00	90.00	179.92	8,834.00	-5,087.48	-883.78	5,154.10	0.00	0.00	0.00	
13,725.00	90.00	179.92	8,834.00	-5,102.48	-883.76	5,169.01	0.00	0.00	0.00	
13,740.00	90.00	179.92	8,834.00	-5,117.48	-883.74	5,183.91	0.00	0.00	0.00	
13,755.00	90.00	179.92	8,834.00	-5,132.48	-883.72	5,198.82	0.00	0.00	0.00	
13,770.00	90.00	179.92	8,834.00	-5,147.48	-883.70	5,213.72	0.00	0.00	0.00	
13,785.00	90.00	179.92	8,834.00	-5,162.48	-883.67	5,228.63	0.00	0.00	0.00	
13,800.00	90.00	179.92	8,834.00	-5,177.48	-883.65	5,243.53	0.00	0.00	0.00	
13,815.00	90.00	179.92	8,834.00	-5,192.48	-883.63	5,258.44	0.00	0.00	0.00	
13,830.00	90.00	179.92	8,834.00	-5,207.48	-883.61	5,273.34	0.00	0.00	0.00	
13,845.00	90.00	179.92	8,834.00	-5,222.48	-883.59	5,288.25	0.00	0.00	0.00	
13,860.00	90.00	179.92	8,834.00	-5,237.48	-883.57	5,303.15	0.00	0.00	0.00	
13,875.00	90.00	179.92	8,834.00	-5,252.48	-883.54	5,318.06	0.00	0.00	0.00	
13,890.00	90.00	179.92	8,834.00	-5,267.48	-883.52	5,332.96	0.00	0.00	0.00	
13,905.00	90.00	179.92	8,834.00	-5,282.48	-883.50	5,347.87	0.00	0.00	0.00	
13,920.00	90.00	179.92	8,834.00	-5,297.48	-883.48	5,362.77	0.00	0.00	0.00	
13,935.00	90.00	179.92	8,834.00	-5,312.48	-883.46	5,377.68	0.00	0.00	0.00	
13,950.00	90.00	179.92	8,834.00	-5,327.48	-883.44	5,392.58	0.00	0.00	0.00	
13,965.00	90.00	179.92	8,834.00	-5,342.48	-883.41	5,407.49	0.00	0.00	0.00	
13,980.00	90.00	179.92	8,834.00	-5,357.48	-883.39	5,422.39	0.00	0.00	0.00	
13,995.00	90.00	179.92	8,834.00	-5,372.48	-883.37	5,437.30	0.00	0.00	0.00	
14,010.00	90.00	179.92	8,834.00	-5,387.48	-883.35	5,452.20	0.00	0.00	0.00	
14,025.00	90.00	179.92	8,834.00	-5,402.48	-883.33	5,467.11	0.00	0.00	0.00	
14,040.00	90.00	179.92	8,834.00	-5,417.48	-883.31	5,482.01	0.00	0.00	0.00	
14,055.00	90.00	179.92	8,834.00	-5,432.48	-883.28	5,496.92	0.00	0.00	0.00	
14,070.00	90.00	179.92	8,834.00	-5,447.48	-883.26	5,511.82	0.00	0.00	0.00	
14,085.00	90.00	179.92	8,834.00	-5,462.48	-883.24	5,526.73	0.00	0.00	0.00	
14,100.00	90.00	179.92	8,834.00	-5,477.48	-883.22	5,541.63	0.00	0.00	0.00	
14,115.00	90.00	179.92	8,834.00	-5,492.48	-883.20	5,556.54	0.00	0.00	0.00	
14,130.00	90.00	179.92	8,834.00	-5,507.48	-883.18	5,571.44	0.00	0.00	0.00	
14,145.00	90.00	179.92	8,834.00	-5,522.48	-883.15	5,586.35	0.00	0.00	0.00	
14,160.00	90.00	179.92	8,834.00	-5,537.48	-883.13	5,601.25	0.00	0.00	0.00	
14,175.00	90.00	179.92	8,834.00	-5,552.48	-883.11	5,616.16	0.00	0.00	0.00	
14,190.00	90.00	179.92	8,834.00	-5,567.48	-883.09	5,631.06	0.00	0.00	0.00	
14,205.00	90.00	179.92	8,834.00	-5,582.48	-883.07	5,645.97	0.00	0.00	0.00	
14,220.00	90.00	179.92	8,834.00	-5,597.48	-883.04	5,660.87	0.00	0.00	0.00	
14,235.00	90.00	179.92	8,834.00	-5,612.48	-883.02	5,675.78	0.00	0.00	0.00	
14,250.00	90.00	179.92	8,834.00	-5,627.48	-883.00	5,690.68	0.00	0.00	0.00	
14,265.00	90.00	179.92	8,834.00	-5,642.48	-882.98	5,705.59	0.00	0.00	0.00	
14,280.00	90.00	179.92	8,834.00	-5,657.48	-882.96	5,720.49	0.00	0.00	0.00	
14,295.00	90.00	179.92	8,834.00	-5,672.48	-882.94	5,735.40	0.00	0.00	0.00	
14,310.00	90.00	179.92	8,834.00	-5,687.48	-882.91	5,750.31	0.00	0.00	0.00	
14,325.00	90.00	179.92	8,834.00	-5,702.48	-882.89	5,765.21	0.00	0.00	0.00	
14,340.00	90.00	179.92	8,834.00	-5,717.48	-882.87	5,780.12	0.00	0.00	0.00	
14,355.00	90.00	179.92	8,834.00	-5,732.48	-882.85	5,795.02	0.00	0.00	0.00	
14,370.00	90.00	179.92	8,834.00	-5,747.48	-882.83	5,809.93	0.00	0.00	0.00	
14,385.00	90.00	179.92	8,834.00	-5,762.48	-882.81	5,824.83	0.00	0.00	0.00	
14,400.00	90.00	179.92	8,834.00	-5,777.48	-882.78	5,839.74	0.00	0.00	0.00	
14,415.00	90.00	179.92	8,834.00	-5,792.48	-882.76	5,854.64	0.00	0.00	0.00	
14,430.00	90.00	179.92	8,834.00	-5,807.48	-882.74	5,869.55	0.00	0.00	0.00	
14,445.00	90.00	179.92	8,834.00	-5,822.48	-882.72	5,884.45	0.00	0.00	0.00	
14,460.00	90.00	179.92	8,834.00	-5,837.48	-882.70	5,899.36	0.00	0.00	0.00	
14,475.00	90.00	179.92	8,834.00	-5,852.48	-882.68	5,914.26	0.00	0.00	0.00	

ConocoPhillips

Planning Report

Database:	EDT 17 Permian Prod	Local Co-ordinate Reference:	Well _SWEET TEA FEDERAL COM 552H
Company:	DELAWARE BASIN WEST	TVD Reference:	GL @ 2920.00usft
Project:	ATLAS PROSPECT_NME	MD Reference:	GL @ 2920.00usft
Site:	SWEET TEA FED COM PROJECT	North Reference:	Grid
Well:	_SWEET TEA FEDERAL COM 552H	Survey Calculation Method:	Minimum Curvature
Wellbore:	OWB		
Design:	PWP0		

Planned Survey									
Measured Depth (usft)	Inclination (°)	Azimuth (°)	Vertical Depth (usft)	+N/-S (usft)	+E/-W (usft)	Vertical Section (usft)	Dogleg Rate (°/100usft)	Build Rate (°/100usft)	Turn Rate (°/100usft)
14,490.00	90.00	179.92	8,834.00	-5,867.48	-882.65	5,929.17	0.00	0.00	0.00
14,505.00	90.00	179.92	8,834.00	-5,882.48	-882.63	5,944.07	0.00	0.00	0.00
14,520.00	90.00	179.92	8,834.00	-5,897.48	-882.61	5,958.98	0.00	0.00	0.00
14,535.00	90.00	179.92	8,834.00	-5,912.48	-882.59	5,973.88	0.00	0.00	0.00
14,550.00	90.00	179.92	8,834.00	-5,927.48	-882.57	5,988.79	0.00	0.00	0.00
14,565.00	90.00	179.92	8,834.00	-5,942.48	-882.55	6,003.69	0.00	0.00	0.00
14,580.00	90.00	179.92	8,834.00	-5,957.48	-882.52	6,018.60	0.00	0.00	0.00
14,595.00	90.00	179.92	8,834.00	-5,972.48	-882.50	6,033.50	0.00	0.00	0.00
14,610.00	90.00	179.92	8,834.00	-5,987.48	-882.48	6,048.41	0.00	0.00	0.00
14,625.00	90.00	179.92	8,834.00	-6,002.48	-882.46	6,063.31	0.00	0.00	0.00
14,640.00	90.00	179.92	8,834.00	-6,017.48	-882.44	6,078.22	0.00	0.00	0.00
14,655.00	90.00	179.92	8,834.00	-6,032.48	-882.41	6,093.12	0.00	0.00	0.00
14,670.00	90.00	179.92	8,834.00	-6,047.48	-882.39	6,108.03	0.00	0.00	0.00
14,685.00	90.00	179.92	8,834.00	-6,062.48	-882.37	6,122.93	0.00	0.00	0.00
14,700.00	90.00	179.92	8,834.00	-6,077.48	-882.35	6,137.84	0.00	0.00	0.00
14,715.00	90.00	179.92	8,834.00	-6,092.48	-882.33	6,152.74	0.00	0.00	0.00
14,730.00	90.00	179.92	8,834.00	-6,107.48	-882.31	6,167.65	0.00	0.00	0.00
14,745.00	90.00	179.92	8,834.00	-6,122.48	-882.28	6,182.55	0.00	0.00	0.00
14,760.00	90.00	179.92	8,834.00	-6,137.48	-882.26	6,197.46	0.00	0.00	0.00
14,775.00	90.00	179.92	8,834.00	-6,152.48	-882.24	6,212.36	0.00	0.00	0.00
14,790.00	90.00	179.92	8,834.00	-6,167.48	-882.22	6,227.27	0.00	0.00	0.00
14,805.00	90.00	179.92	8,834.00	-6,182.48	-882.20	6,242.17	0.00	0.00	0.00
14,820.00	90.00	179.92	8,834.00	-6,197.48	-882.18	6,257.08	0.00	0.00	0.00
14,835.00	90.00	179.92	8,834.00	-6,212.48	-882.15	6,271.98	0.00	0.00	0.00
14,850.00	90.00	179.92	8,834.00	-6,227.48	-882.13	6,286.89	0.00	0.00	0.00
14,865.00	90.00	179.92	8,834.00	-6,242.48	-882.11	6,301.79	0.00	0.00	0.00
14,880.00	90.00	179.92	8,834.00	-6,257.48	-882.09	6,316.70	0.00	0.00	0.00
14,895.00	90.00	179.92	8,834.00	-6,272.48	-882.07	6,331.60	0.00	0.00	0.00
14,910.00	90.00	179.92	8,834.00	-6,287.48	-882.05	6,346.51	0.00	0.00	0.00
14,925.00	90.00	179.92	8,834.00	-6,302.48	-882.02	6,361.41	0.00	0.00	0.00
14,940.00	90.00	179.92	8,834.00	-6,317.48	-882.00	6,376.32	0.00	0.00	0.00
14,955.00	90.00	179.92	8,834.00	-6,332.48	-881.98	6,391.22	0.00	0.00	0.00
14,970.00	90.00	179.92	8,834.00	-6,347.48	-881.96	6,406.13	0.00	0.00	0.00
14,985.00	90.00	179.92	8,834.00	-6,362.48	-881.94	6,421.03	0.00	0.00	0.00
15,000.00	90.00	179.92	8,834.00	-6,377.48	-881.92	6,435.94	0.00	0.00	0.00
15,015.00	90.00	179.92	8,834.00	-6,392.48	-881.89	6,450.84	0.00	0.00	0.00
15,030.00	90.00	179.92	8,834.00	-6,407.48	-881.87	6,465.75	0.00	0.00	0.00
15,045.00	90.00	179.92	8,834.00	-6,422.48	-881.85	6,480.66	0.00	0.00	0.00
15,060.00	90.00	179.92	8,834.00	-6,437.48	-881.83	6,495.56	0.00	0.00	0.00
15,075.00	90.00	179.92	8,834.00	-6,452.48	-881.81	6,510.47	0.00	0.00	0.00
15,090.00	90.00	179.92	8,834.00	-6,467.48	-881.78	6,525.37	0.00	0.00	0.00
15,105.00	90.00	179.92	8,834.00	-6,482.48	-881.76	6,540.28	0.00	0.00	0.00
15,120.00	90.00	179.92	8,834.00	-6,497.48	-881.74	6,555.18	0.00	0.00	0.00
15,135.00	90.00	179.92	8,834.00	-6,512.48	-881.72	6,570.09	0.00	0.00	0.00
15,150.00	90.00	179.92	8,834.00	-6,527.48	-881.70	6,584.99	0.00	0.00	0.00
15,165.00	90.00	179.92	8,834.00	-6,542.48	-881.68	6,599.90	0.00	0.00	0.00
15,180.00	90.00	179.92	8,834.00	-6,557.48	-881.65	6,614.80	0.00	0.00	0.00
15,195.00	90.00	179.92	8,834.00	-6,572.48	-881.63	6,629.71	0.00	0.00	0.00
15,210.00	90.00	179.92	8,834.00	-6,587.48	-881.61	6,644.61	0.00	0.00	0.00
15,225.00	90.00	179.92	8,834.00	-6,602.48	-881.59	6,659.52	0.00	0.00	0.00
15,240.00	90.00	179.92	8,834.00	-6,617.48	-881.57	6,674.42	0.00	0.00	0.00
15,255.00	90.00	179.92	8,834.00	-6,632.48	-881.55	6,689.33	0.00	0.00	0.00
15,270.00	90.00	179.92	8,834.00	-6,647.48	-881.52	6,704.23	0.00	0.00	0.00
15,285.00	90.00	179.92	8,834.00	-6,662.48	-881.50	6,719.14	0.00	0.00	0.00

ConocoPhillips

Planning Report

Database:	EDT 17 Permian Prod	Local Co-ordinate Reference:	Well _SWEET TEA FEDERAL COM 552H
Company:	DELAWARE BASIN WEST	TVD Reference:	GL @ 2920.00usft
Project:	ATLAS PROSPECT_NME	MD Reference:	GL @ 2920.00usft
Site:	SWEET TEA FED COM PROJECT	North Reference:	Grid
Well:	_SWEET TEA FEDERAL COM 552H	Survey Calculation Method:	Minimum Curvature
Wellbore:	OWB		
Design:	PWP0		

Planned Survey										
Measured Depth (usft)	Inclination (°)	Azimuth (°)	Vertical Depth (usft)	+N/-S (usft)	+E/-W (usft)	Vertical Section (usft)	Dogleg Rate (°/100usft)	Build Rate (°/100usft)	Turn Rate (°/100usft)	
15,300.00	90.00	179.92	8,834.00	-6,677.48	-881.48	6,734.04	0.00	0.00	0.00	
15,315.00	90.00	179.92	8,834.00	-6,692.48	-881.46	6,748.95	0.00	0.00	0.00	
15,330.00	90.00	179.92	8,834.00	-6,707.48	-881.44	6,763.85	0.00	0.00	0.00	
15,345.00	90.00	179.92	8,834.00	-6,722.48	-881.42	6,778.76	0.00	0.00	0.00	
15,360.00	90.00	179.92	8,834.00	-6,737.48	-881.39	6,793.66	0.00	0.00	0.00	
15,375.00	90.00	179.92	8,834.00	-6,752.48	-881.37	6,808.57	0.00	0.00	0.00	
15,390.00	90.00	179.92	8,834.00	-6,767.48	-881.35	6,823.47	0.00	0.00	0.00	
15,405.00	90.00	179.92	8,834.00	-6,782.48	-881.33	6,838.38	0.00	0.00	0.00	
15,420.00	90.00	179.92	8,834.00	-6,797.48	-881.31	6,853.28	0.00	0.00	0.00	
15,435.00	90.00	179.92	8,834.00	-6,812.48	-881.28	6,868.19	0.00	0.00	0.00	
15,450.00	90.00	179.92	8,834.00	-6,827.48	-881.26	6,883.09	0.00	0.00	0.00	
15,465.00	90.00	179.92	8,834.00	-6,842.48	-881.24	6,898.00	0.00	0.00	0.00	
15,480.00	90.00	179.92	8,834.00	-6,857.48	-881.22	6,912.90	0.00	0.00	0.00	
15,495.00	90.00	179.92	8,834.00	-6,872.48	-881.20	6,927.81	0.00	0.00	0.00	
15,510.00	90.00	179.92	8,834.00	-6,887.48	-881.18	6,942.71	0.00	0.00	0.00	
15,525.00	90.00	179.92	8,834.00	-6,902.48	-881.15	6,957.62	0.00	0.00	0.00	
15,540.00	90.00	179.92	8,834.00	-6,917.48	-881.13	6,972.52	0.00	0.00	0.00	
15,555.00	90.00	179.92	8,834.00	-6,932.48	-881.11	6,987.43	0.00	0.00	0.00	
15,570.00	90.00	179.92	8,834.00	-6,947.48	-881.09	7,002.33	0.00	0.00	0.00	
15,585.00	90.00	179.92	8,834.00	-6,962.48	-881.07	7,017.24	0.00	0.00	0.00	
15,600.00	90.00	179.92	8,834.00	-6,977.48	-881.05	7,032.14	0.00	0.00	0.00	
15,615.00	90.00	179.92	8,834.00	-6,992.48	-881.02	7,047.05	0.00	0.00	0.00	
15,630.00	90.00	179.92	8,834.00	-7,007.48	-881.00	7,061.95	0.00	0.00	0.00	
15,645.00	90.00	179.92	8,834.00	-7,022.48	-880.98	7,076.86	0.00	0.00	0.00	
15,660.00	90.00	179.92	8,834.00	-7,037.48	-880.96	7,091.76	0.00	0.00	0.00	
15,675.00	90.00	179.92	8,834.00	-7,052.48	-880.94	7,106.67	0.00	0.00	0.00	
15,690.00	90.00	179.92	8,834.00	-7,067.48	-880.92	7,121.57	0.00	0.00	0.00	
15,705.00	90.00	179.92	8,834.00	-7,082.48	-880.89	7,136.48	0.00	0.00	0.00	
15,720.00	90.00	179.92	8,834.00	-7,097.48	-880.87	7,151.38	0.00	0.00	0.00	
15,735.00	90.00	179.92	8,834.00	-7,112.48	-880.85	7,166.29	0.00	0.00	0.00	
15,750.00	90.00	179.92	8,834.00	-7,127.48	-880.83	7,181.19	0.00	0.00	0.00	
15,765.00	90.00	179.92	8,834.00	-7,142.48	-880.81	7,196.10	0.00	0.00	0.00	
15,780.00	90.00	179.92	8,834.00	-7,157.48	-880.79	7,211.01	0.00	0.00	0.00	
15,795.00	90.00	179.92	8,834.00	-7,172.48	-880.76	7,225.91	0.00	0.00	0.00	
15,810.00	90.00	179.92	8,834.00	-7,187.48	-880.74	7,240.82	0.00	0.00	0.00	
15,825.00	90.00	179.92	8,834.00	-7,202.48	-880.72	7,255.72	0.00	0.00	0.00	
15,840.00	90.00	179.92	8,834.00	-7,217.48	-880.70	7,270.63	0.00	0.00	0.00	
15,855.00	90.00	179.92	8,834.00	-7,232.48	-880.68	7,285.53	0.00	0.00	0.00	
15,870.00	90.00	179.92	8,834.00	-7,247.48	-880.65	7,300.44	0.00	0.00	0.00	
15,885.00	90.00	179.92	8,834.00	-7,262.48	-880.63	7,315.34	0.00	0.00	0.00	
15,900.00	90.00	179.92	8,834.00	-7,277.48	-880.61	7,330.25	0.00	0.00	0.00	
15,915.00	90.00	179.92	8,834.00	-7,292.48	-880.59	7,345.15	0.00	0.00	0.00	
15,930.00	90.00	179.92	8,834.00	-7,307.48	-880.57	7,360.06	0.00	0.00	0.00	
15,945.00	90.00	179.92	8,834.00	-7,322.48	-880.55	7,374.96	0.00	0.00	0.00	
15,960.00	90.00	179.92	8,834.00	-7,337.48	-880.52	7,389.87	0.00	0.00	0.00	
15,975.00	90.00	179.92	8,834.00	-7,352.48	-880.50	7,404.77	0.00	0.00	0.00	
15,990.00	90.00	179.92	8,834.00	-7,367.48	-880.48	7,419.68	0.00	0.00	0.00	
16,005.00	90.00	179.92	8,834.00	-7,382.48	-880.46	7,434.58	0.00	0.00	0.00	
16,020.00	90.00	179.92	8,834.00	-7,397.48	-880.44	7,449.49	0.00	0.00	0.00	
16,035.00	90.00	179.92	8,834.00	-7,412.48	-880.42	7,464.39	0.00	0.00	0.00	
16,050.00	90.00	179.92	8,834.00	-7,427.48	-880.39	7,479.30	0.00	0.00	0.00	
16,065.00	90.00	179.92	8,834.00	-7,442.48	-880.37	7,494.20	0.00	0.00	0.00	
16,080.00	90.00	179.92	8,834.00	-7,457.48	-880.35	7,509.11	0.00	0.00	0.00	
16,095.00	90.00	179.92	8,834.00	-7,472.48	-880.33	7,524.01	0.00	0.00	0.00	

ConocoPhillips Planning Report

Database:	EDT 17 Permian Prod	Local Co-ordinate Reference:	Well _SWEET TEA FEDERAL COM 552H
Company:	DELAWARE BASIN WEST	TVD Reference:	GL @ 2920.00usft
Project:	ATLAS PROSPECT_NME	MD Reference:	GL @ 2920.00usft
Site:	SWEET TEA FED COM PROJECT	North Reference:	Grid
Well:	_SWEET TEA FEDERAL COM 552H	Survey Calculation Method:	Minimum Curvature
Wellbore:	OWB		
Design:	PWPO		

Planned Survey										
Measured Depth (usft)	Inclination (°)	Azimuth (°)	Vertical Depth (usft)	+N/-S (usft)	+E/-W (usft)	Vertical Section (usft)	Dogleg Rate (°/100usft)	Build Rate (°/100usft)	Turn Rate (°/100usft)	
16,110.00	90.00	179.92	8,834.00	-7,487.48	-880.31	7,538.92	0.00	0.00	0.00	
16,125.00	90.00	179.92	8,834.00	-7,502.48	-880.29	7,553.82	0.00	0.00	0.00	
16,140.00	90.00	179.92	8,834.00	-7,517.48	-880.26	7,568.73	0.00	0.00	0.00	
16,155.00	90.00	179.92	8,834.00	-7,532.48	-880.24	7,583.63	0.00	0.00	0.00	
16,170.00	90.00	179.92	8,834.00	-7,547.48	-880.22	7,598.54	0.00	0.00	0.00	
16,185.00	90.00	179.92	8,834.00	-7,562.48	-880.20	7,613.44	0.00	0.00	0.00	
16,200.00	90.00	179.92	8,834.00	-7,577.48	-880.18	7,628.35	0.00	0.00	0.00	
16,215.00	90.00	179.92	8,834.00	-7,592.48	-880.16	7,643.25	0.00	0.00	0.00	
16,230.00	90.00	179.92	8,834.00	-7,607.48	-880.13	7,658.16	0.00	0.00	0.00	
16,245.00	90.00	179.92	8,834.00	-7,622.48	-880.11	7,673.06	0.00	0.00	0.00	
16,260.00	90.00	179.92	8,834.00	-7,637.48	-880.09	7,687.97	0.00	0.00	0.00	
16,275.00	90.00	179.92	8,834.00	-7,652.48	-880.07	7,702.87	0.00	0.00	0.00	
16,290.00	90.00	179.92	8,834.00	-7,667.48	-880.05	7,717.78	0.00	0.00	0.00	
16,305.00	90.00	179.92	8,834.00	-7,682.48	-880.02	7,732.68	0.00	0.00	0.00	
16,320.00	90.00	179.92	8,834.00	-7,697.48	-880.00	7,747.59	0.00	0.00	0.00	
16,335.00	90.00	179.92	8,834.00	-7,712.48	-879.98	7,762.49	0.00	0.00	0.00	
16,350.00	90.00	179.92	8,834.00	-7,727.48	-879.96	7,777.40	0.00	0.00	0.00	
16,365.00	90.00	179.92	8,834.00	-7,742.48	-879.94	7,792.30	0.00	0.00	0.00	
16,380.00	90.00	179.92	8,834.00	-7,757.48	-879.92	7,807.21	0.00	0.00	0.00	
16,395.00	90.00	179.92	8,834.00	-7,772.48	-879.89	7,822.11	0.00	0.00	0.00	
16,410.00	90.00	179.92	8,834.00	-7,787.48	-879.87	7,837.02	0.00	0.00	0.00	
16,425.00	90.00	179.92	8,834.00	-7,802.48	-879.85	7,851.92	0.00	0.00	0.00	
16,440.00	90.00	179.92	8,834.00	-7,817.48	-879.83	7,866.83	0.00	0.00	0.00	
16,455.00	90.00	179.92	8,834.00	-7,832.48	-879.81	7,881.73	0.00	0.00	0.00	
16,470.00	90.00	179.92	8,834.00	-7,847.48	-879.79	7,896.64	0.00	0.00	0.00	
16,485.00	90.00	179.92	8,834.00	-7,862.48	-879.76	7,911.54	0.00	0.00	0.00	
16,500.00	90.00	179.92	8,834.00	-7,877.48	-879.74	7,926.45	0.00	0.00	0.00	
16,508.52	90.00	179.92	8,834.00	-7,886.00	-879.73	7,934.92	0.00	0.00	0.00	

Design Targets										
Target Name	Dip Angle (°)	Dip Dir. (°)	TVD (usft)	+N/-S (usft)	+E/-W (usft)	Northing (usft)	Easting (usft)	Latitude	Longitude	
FTP_SWEET TEA FEDE - hit/miss target - Shape	0.00	0.00	8,824.00	-84.68	-891.03	426,913.43	594,201.16	32° 10' 24.008 N	104° 1' 43.968 W	
- plan misses target center by 190.74usft at 8805.00usft MD (8690.85 TVD, -221.25 N, -890.83 E)										
- Circle (radius 50.00)										
PBHL_SWEET TEA FEI - plan hits target center - Rectangle (sides W100.00 H7,801.00 D20.00)	-0.08	359.92	8,834.00	-7,886.00	-879.73	419,112.11	594,212.46	32° 9' 6.803 N	104° 1' 44.093 W	
LTP_SWEET TEA FEDE - plan misses target center by 0.01usft at 16458.51usft MD (8834.00 TVD, -7835.99 N, -879.80 E) - Circle (radius 50.00)	90.00	179.92	8,834.00	-7,835.99	-879.81	419,162.12	594,212.38	32° 9' 7.298 N	104° 1' 44.092 W	

Casing Points					
Measured Depth (usft)	Vertical Depth (usft)	Name	Casing Diameter (")	Hole Diameter (")	
16,614.94	8,834.00	5-1/2" Production Casing	5-1/2	6	

ConocoPhillips

Planning Report

Database:	EDT 17 Permian Prod	Local Co-ordinate Reference:	Well _SWEET TEA FEDERAL COM 552H
Company:	DELAWARE BASIN WEST	TVD Reference:	GL @ 2920.00usft
Project:	ATLAS PROSPECT_NME	MD Reference:	GL @ 2920.00usft
Site:	SWEET TEA FED COM PROJECT	North Reference:	Grid
Well:	_SWEET TEA FEDERAL COM 552H	Survey Calculation Method:	Minimum Curvature
Wellbore:	OWB		
Design:	PWP0		



TXP[®] BTC



Coupling	Pipe Body
Grade: P110-CY	Grade: P110-CY
Body: White	1st Band: White
1st Band: Grey	2nd Band: Grey
2nd Band: -	3rd Band: -
3rd Band: -	4th Band: -
	5th Band: -
	6th Band: -

Outside Diameter	5.500 in.	Wall Thickness	0.415 in.	Grade	P110-CY
Min. Wall Thickness	87.50 %	Pipe Body Drift	API Standard	Type	Casing
Connection OD Option	REGULAR				

Pipe Body Data

Geometry				Performance	
Nominal OD	5.500 in.	Wall Thickness	0.415 in.	Body Yield Strength	729 x1000 lb
Nominal Weight	23 lb/ft	Plain End Weight	22.56 lb/ft	Min. Internal Yield Pressure	14,530 psi
Drift	4.545 in.	OD Tolerance	API	SMYS	110,000 psi
Nominal ID	4.670 in.			Collapse Pressure	14,540 psi

Connection Data

Geometry		Performance		Make-Up Torques	
Connection OD	6.200 in.	Tension Efficiency	100 %	Minimum	12,980 ft-lb
Coupling Length	9.450 in.	Joint Yield Strength	729 x1000 lb	Optimum	14,420 ft-lb
Connection ID	4.658 in.	Internal Pressure Capacity	14,530 psi	Maximum	15,860 ft-lb
Make-up Loss	4.204 in.	Compression Efficiency	100 %		
Threads per inch	5	Compression Strength	729 x1000 lb	Operation Limit Torques	
Connection OD Option	Regular	Max. Allowable Bending	92 °/100 ft	Operating Torque	24,200 ft-lb
		External Pressure Capacity	14,540 psi	Yield Torque	26,900 ft-lb

Notes

This connection is fully interchangeable with:
 TXP[®] BTC - 5.5 in. - 0.275 / 0.304 / 0.361 / 0.476 in.
 Connections with Dopeless[®] Technology are fully compatible with the same connection in its Standard version
 Datasheet is also valid for Special Bevel option when applicable - except for Coupling Face Load, which will be reduced. Please contact a local Tenaris technical sales representative.
 Standard coupling design comes with optimized 20° bevel.

For the latest performance data, always visit our website: www.tenaris.com

Tenaris has issued this document for general information only, and the information in this document, including, without limitation, any pictures, drawings or designs ("Information") is not intended to constitute professional or any other type of advice or recommendation and is provided on an "as is" basis. No warranty is given. Tenaris has not independently verified any information—if any- provided by the user in connection with, or for the purpose of, the Information contained hereunder. The use of the Information is at user's own risk and Tenaris does not assume any responsibility or liability of any kind for any loss, damage or injury resulting from, or in connection with any Information contained hereunder or any use thereof. The Information in this document is subject to change or modification without notice. Tenaris's products and services are subject to Tenaris's standard terms and conditions or otherwise to the terms resulting from the respective contracts of sale or services, as the case may be, between petitioner and Tenaris. For more complete information please contact a Tenaris's representative or visit our website at www.tenaris.com. ©Tenaris 2022. All rights reserved.



TenarisHydril Wedge 441®



Coupling	Pipe Body
Grade: P110-CY	Grade: P110-CY
Body: White	1st Band: White
1st Band: Grey	2nd Band: Grey
2nd Band: -	3rd Band: -
3rd Band: -	4th Band: -
	5th Band: -
	6th Band: -

Outside Diameter	5.500 in.	Wall Thickness	0.415 in.	Grade	P110-CY
Min. Wall Thickness	87.50 %	Pipe Body Drift	API Standard	Type	Casing
Connection OD Option	REGULAR				

Pipe Body Data

Geometry		Performance	
Nominal OD	5.500 in.	Wall Thickness	0.415 in.
Nominal Weight	23 lb/ft	Plain End Weight	22.56 lb/ft
Drift	4.545 in.	OD Tolerance	API
Nominal ID	4.670 in.		
		Body Yield Strength	729 x1000 lb
		Min. Internal Yield Pressure	14,530 psi
		SMYS	110,000 psi
		Collapse Pressure	14,540 psi

Connection Data

Geometry		Performance		Make-Up Torques	
Connection OD	5.900 in.	Tension Efficiency	90.80 %	Minimum	15,000 ft-lb
Coupling Length	8.714 in.	Joint Yield Strength	662 x1000 lb	Optimum	16,000 ft-lb
Connection ID	4.670 in.	Internal Pressure Capacity	14,530 psi	Maximum	19,200 ft-lb
Make-up Loss	3.780 in.	Compression Efficiency	90.80 %		
Threads per inch	3.40	Compression Strength	662 x1000 lb	Operation Limit Torques	
Connection OD Option	Regular	Max. Allowable Bending	79 °/100 ft	Operating Torque	33,000 ft-lb
		External Pressure Capacity	14,540 psi	Yield Torque	39,000 ft-lb
		Coupling Face Load	172,000 lb	Buck-On	
				Minimum	19,200 ft-lb
				Maximum	20,700 ft-lb

Notes

This connection is fully interchangeable with:
 Wedge 441® - 5.5 in. - 0.476 in.
 Connections with Dopeless® Technology are fully compatible with the same connection in its Standard version

For the latest performance data, always visit our website: www.tenaris.com

Tenaris has issued this document for general information only, and the information in this document, including, without limitation, any pictures, drawings or designs ("Information") is not intended to constitute professional or any other type of advice or recommendation and is provided on an "as is" basis. No warranty is given. Tenaris has not independently verified any information—if any—provided by the user in connection with, or for the purpose of, the Information contained hereunder. The use of the Information is at user's own risk and Tenaris does not assume any responsibility or liability of any kind for any loss, damage or injury resulting from, or in connection with any Information contained hereunder or any use thereof. The Information in this document is subject to change or modification without notice. Tenaris's products and services are subject to Tenaris's standard terms and conditions or otherwise to the terms resulting from the respective contracts of sale or services, as the case may be, between petitioner and Tenaris. For more complete information please contact a Tenaris's representative or visit our website at www.tenaris.com. ©Tenaris 2022. All rights reserved.



Wedge 513[®]

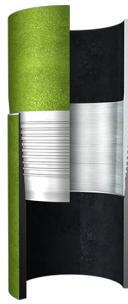

Coupling	Pipe Body
Grade: P110-ICY	Grade: P110-ICY
Body: White	1st Band: White
1st Band: Pale Green	2nd Band: Pale Green
2nd Band: -	3rd Band: Pale Green
3rd Band: -	4th Band: -
	5th Band: -
	6th Band: -

Outside Diameter	7.625 in.	Wall Thickness	0.375 in.	Grade	P110-ICY
Min. Wall Thickness	90.00 %	Pipe Body Drift	API Standard	Type	Casing
Connection OD Option	REGULAR				

Pipe Body Data

Geometry				Performance	
Nominal OD	7.625 in.	Wall Thickness	0.375 in.	Body Yield Strength	1068 x1000 lb
Nominal Weight	29.70 lb/ft	Plain End Weight	29.06 lb/ft	Min. Internal Yield Pressure	11,070 psi
Drift	6.750 in.	OD Tolerance	API	SMYS	125,000 psi
Nominal ID	6.875 in.			Collapse Pressure	7360 psi

Connection Data

Geometry		Performance		Make-Up Torques	
Connection OD	7.625 in.	Tension Efficiency	60 %	Minimum	9000 ft-lb
Connection ID	6.800 in.	Joint Yield Strength	641 x1000 lb	Optimum	10,800 ft-lb
Make-up Loss	4.420 in.	Internal Pressure Capacity	11,070 psi	Maximum	15,800 ft-lb
Threads per inch	3.29	Compression Efficiency	75.20 %	Operation Limit Torques	
Connection OD Option	Regular	Compression Strength	803 x1000 lb	Operating Torque	53,000 ft-lb
		Max. Allowable Bending	45 °/100 ft	Yield Torque	79,000 ft-lb
		External Pressure Capacity	7360 psi		

Notes

This connection is fully interchangeable with:
 Wedge 523[®] - 7.625 in. - 0.375 in.
 Connections with Dopeless[®] Technology are fully compatible with the same connection in its Standard version

For the latest performance data, always visit our website: www.tenaris.com

Tenaris has issued this document for general information only, and the information in this document, including, without limitation, any pictures, drawings or designs ("Information") is not intended to constitute professional or any other type of advice or recommendation and is provided on an "as is" basis. No warranty is given. Tenaris has not independently verified any information—if any—provided by the user in connection with, or for the purpose of, the Information contained hereunder. The use of the Information is at user's own risk and Tenaris does not assume any responsibility or liability of any kind for any loss, damage or injury resulting from, or in connection with any Information contained hereunder or any use thereof. The Information in this document is subject to change or modification without notice. Tenaris's products and services are subject to Tenaris's standard terms and conditions or otherwise to the terms resulting from the respective contracts of sale or services, as the case may be, between petitioner and Tenaris. For more complete information please contact a Tenaris's representative or visit our website at www.tenaris.com. ©Tenaris 2022. All rights reserved.

PECOS DISTRICT DRILLING CONDITIONS OF APPROVAL

OPERATOR'S NAME:	CONOCOPHILLIPS COMPANY
WELL NAME & NO.:	SWEET TEA FEDERAL COM 552H
LOCATION:	Section 31, T.24 S., R.29 E., NMP
COUNTY:	Eddy County, New Mexico

COA

H2S	<input checked="" type="radio"/> Yes	<input type="radio"/> No	
Potash	<input checked="" type="radio"/> None	<input type="radio"/> Secretary	<input type="radio"/> R-111-P
Cave/Karst Potential	<input type="radio"/> Low	<input type="radio"/> Medium	<input checked="" type="radio"/> High
Cave/Karst Potential	<input type="radio"/> Critical		
Variance	<input type="radio"/> None	<input checked="" type="radio"/> Flex Hose	<input type="radio"/> Other
Wellhead	<input type="radio"/> Conventional	<input checked="" type="radio"/> Multibowl	<input type="radio"/> Both
Wellhead Variance	<input type="radio"/> Diverter		
Other	<input type="checkbox"/> 4 String	<input type="checkbox"/> Capitan Reef	<input type="checkbox"/> WIPP
Other	<input checked="" type="checkbox"/> Fluid Filled	<input type="checkbox"/> Pilot Hole	<input type="checkbox"/> Open Annulus
Cementing	<input checked="" type="checkbox"/> Contingency Cement Squeeze	<input checked="" type="checkbox"/> EchoMeter	<input type="checkbox"/> Primary Cement Squeeze
Special Requirements	<input type="checkbox"/> Water Disposal	<input checked="" type="checkbox"/> COM	<input type="checkbox"/> Unit
Special Requirements	<input type="checkbox"/> Batch Sundry		
Special Requirements Variance	<input checked="" type="checkbox"/> Break Testing	<input checked="" type="checkbox"/> Offline Cementing	<input checked="" type="checkbox"/> Casing Clearance

A. HYDROGEN SULFIDE

A Hydrogen Sulfide (H2S) Drilling Plan shall be activated AT SPUD. As a result, the Hydrogen Sulfide area must meet 43 CFR part 3170 requirements, which includes equipment and personnel/public protection items. If Hydrogen Sulfide is encountered, please provide measured values and formations to the BLM.

B. CASING

Primary Casing Design:

1. The **10-3/4** inch surface casing shall be set at approximately **970 feet** (a minimum of 70 feet (Eddy County) into the Rustler Anhydrite, above the salt, and below usable fresh water) and cemented to the surface.
 - a. If cement does not circulate to the surface, the appropriate BLM office shall be notified and a temperature survey utilizing an electronic type temperature

survey with surface log readout will be used or a cement bond log shall be run to verify the top of the cement. Temperature survey will be run a minimum of six hours after pumping cement and ideally between 8-10 hours after completing the cement job.

- b. Wait on cement (WOC) time for a primary cement job will be a minimum of **8 hours** or 500 pounds compressive strength, whichever is greater. (This is to include the lead cement)
 - c. Wait on cement (WOC) time for a remedial job will be a minimum of 4 hours after bringing cement to surface or 500 pounds compressive strength, whichever is greater.
 - d. If cement falls back, remedial cementing will be done prior to drilling out that string.
2. The minimum required fill of cement behind the **7-5/8** inch intermediate casing is:
- Cement to surface. If cement does not circulate see B.1.a, c-d above.
Wait on cement (WOC) time for a primary cement job is to include the lead cement slurry due to cave/karst or potash.

Contingency Squeeze:

Operator has proposed to pump down 10-3/4" X 7-5/8" annulus. Operator must top out cement after the bradenhead squeeze and verify cement to surface. Operator can also check TOC with Echo-meter. CBL must be run from TD of the 7-5/8" casing to surface if confidence is lacking on the quality of the bradenhead squeeze cement job. Submit results to BLM.

Submit results to the BLM. No displacement fluid/wash out shall be utilized at the top of the cement slurry between second stage BH and top out. Operator must run one CBL per Well Pad.

If cement does not reach surface, the next casing string must come to surface.

Operator must use a limited flush fluid volume of 1 bbl following backside cementing procedures.

3. The minimum required fill of cement behind the **5-1/2** inch production casing is:
- Cement should tie-back at least **500 feet** into previous casing string. Operator shall provide method of verification.
 - **Wait on cement (WOC) time for a primary cement job is to include the lead cement slurry due to cave/karst or potash.**

Contingency Casing Design:

4. The **13-3/8** inch surface casing shall be set at approximately **970 feet** (a minimum of 25 feet (Lea County) into the Rustler Anhydrite, above the salt, and below usable fresh water) and cemented to the surface.
 - e. If cement does not circulate to the surface, the appropriate BLM office shall be notified and a temperature survey utilizing an electronic type temperature survey with surface log readout will be used or a cement bond log shall be run to verify the top of the cement. Temperature survey will be run a minimum of six hours after pumping cement and ideally between 8-10 hours after completing the cement job.
 - f. Wait on cement (WOC) time for a primary cement job will be a minimum of **8 hours** or 500 pounds compressive strength, whichever is greater. (This is to include the lead cement)
 - g. Wait on cement (WOC) time for a remedial job will be a minimum of 4 hours after bringing cement to surface or 500 pounds compressive strength, whichever is greater.
 - h. If cement falls back, remedial cementing will be done prior to drilling out that string.

5. The minimum required fill of cement behind the **9-5/8** inch intermediate casing is:
 - Cement to surface. If cement does not circulate see B.1.a, c-d above.
Wait on cement (WOC) time for a primary cement job is to include the lead cement slurry due to cave/karst or potash.

6. The minimum required fill of cement behind the **7-5/8** inch intermediate liner is:
 - Cement should tie-back **100 feet** into the previous casing. Operator shall provide method of verification.
Wait on cement (WOC) time for a primary cement job is to include the lead cement slurry due to cave/karst or potash.

Contingency Squeeze:

Operator has proposed to pump down 9-5/8" X 7-5/8" annulus. Operator must top out cement after the bradenhead squeeze and verify cement to surface. Operator can also check TOC with Echo-meter. CBL must be run from TD of the 7-5/8" casing to surface if confidence is lacking on the quality of the bradenhead squeeze cement job. Submit results to BLM.

Submit results to the BLM. No displacement fluid/wash out shall be utilized at the top of the cement slurry between second stage BH and top out. Operator must run one CBL per Well Pad.

If cement does not reach surface, the next casing string must come to surface.

Operator must use a limited flush fluid volume of 1 bbl following backside cementing procedures.

7. The minimum required fill of cement behind the 5-1/2 inch production casing is:
 - Cement should tie-back at least **500 feet** into previous casing string. Operator shall provide method of verification.
 - **Wait on cement (WOC) time for a primary cement job is to include the lead cement slurry due to cave/karst or potash.**

C. PRESSURE CONTROL

1. Variance approved to use flex line from BOP to choke manifold. Manufacturer's specification to be readily available. No external damage to flex line. Flex line to be installed as straight as possible (no hard bends).'
2. Operator has proposed a multi-bowl wellhead assembly. This assembly will only be tested when installed on the 10-3/4 inch surface casing. Minimum working pressure of the blowout preventer (BOP) and related equipment (BOPE) required for drilling below the surface casing shoe shall be **10,000 (10M) psi. Variance is approved to use a 5000 (5M) Annular which shall be tested to 3500 (70% Working Pressure) psi.**
 - a. Wellhead shall be installed by manufacturer's representatives, submit documentation with subsequent sundry.
 - b. If the welding is performed by a third party, the manufacturer's representative shall monitor the temperature to verify that it does not exceed the maximum temperature of the seal.
 - c. Manufacturer representative shall install the test plug for the initial BOP test.
 - d. If the cement does not circulate and one inch operations would have been possible with a standard wellhead, the well head shall be cut off, cementing operations performed and another wellhead installed.
 - e. Whenever any seal subject to test pressure is broken, all the tests in OOGO2.III.A.2.i must be followed.

D. SPECIAL REQUIREMENT (S)

Communitization Agreement

- The operator will submit a Communitization Agreement to the Santa Fe Office, 301 Dinosaur Trail Santa Fe, New Mexico 87508, at least 90 days before the anticipated date of first production from a well subject to a spacing order issued by the New Mexico Oil Conservation Division. The Communitization Agreement will include the

signatures of all working interest owners in all Federal and Indian leases subject to the Communitization Agreement (i.e., operating rights owners and lessees of record), or certification that the operator has obtained the written signatures of all such owners and will make those signatures available to the BLM immediately upon request.

- The operator will submit an as-drilled survey well plat of the well completion, but are not limited to, those specified in Onshore Order 1 and 2.
- If the operator does not comply with this condition of approval, the BLM may take enforcement actions that include, but are not limited to, those specified in 43 CFR 3163.1.
- In addition, the well sign shall include the surface and bottom hole lease numbers. When the Communitization Agreement number is known, it shall also be on the sign.

(Note: For a minimum 5M BOPE or less (Utilizing a 10M BOPE system)

BOPE Break Testing Variance

- BOPE Break Testing is ONLY permitted for 5M BOPE or less. **(Annular preventer must be tested to a minimum of 70% of BOPE working pressure and shall be higher than the MASP)**
- BOPE Break Testing is NOT permitted to drilling the production hole section.
- Variance only pertains to the intermediate hole-sections and no deeper than the Bone Springs formation.
- While in transfer between wells, the BOPE shall be secured by the hydraulic carrier or cradle.
- Any well control event while drilling require notification to the BLM Petroleum Engineer (575-706-2779) prior to the commencement of any BOPE Break Testing operations.
- A full BOPE test is required prior to drilling the first deep intermediate hole section. If any subsequent hole interval is deeper than the first, a full BOPE test will be required. (200' TVD tolerance between intermediate shoes is allowable).
- The BLM is to be contacted (575-361-2822 Eddy County) 4 hours prior to BOPE tests.
- As a minimum, a full BOPE test shall be performed at 21-day intervals.
- In the event any repairs or replacement of the BOPE is required, the BOPE shall test as per Onshore Oil and Gas Order No. 2.
- If in the event break testing is not utilized, then a full BOPE test would be conducted.

Casing Clearance:

- The W441 connection should tie back 500'+ into the W513 intermediate casing for clearance overlap.

Operator shall clean up cycles until wellbore is clear of cuttings and any large debris, ensure cutting sizes are adequate "coffee ground or less" before cementing.

Offline Cementing:

Contact the BLM prior to the commencement of any offline cementing procedure.

GENERAL REQUIREMENTS

The BLM is to be notified in advance for a representative to witness:

- a. Spudding well (minimum of 24 hours)
- b. Setting and/or Cementing of all casing strings (minimum of 4 hours)
- c. BOPE tests (minimum of 4 hours)

Eddy County

EMAIL or call the Carlsbad Field Office, 620 East Greene St., Carlsbad, NM 88220,
BLM_NM_CFO_DrillingNotifications@BLM.GOV
(575) 361-2822

Lea County

Call the Hobbs Field Station, 414 West Taylor, Hobbs NM 88240,
(575) 689-5981

1. Unless the production casing has been run and cemented or the well has been properly plugged, the drilling rig shall not be removed from over the hole without prior approval.
 - a. In the event the operator has proposed to drill multiple wells utilizing a skid/walking rig. Operator shall secure the wellbore on the current well, after installing and testing the wellhead, by installing a blind flange of like pressure rating to the wellhead and a pressure gauge that can be monitored while drilling is performed on the other well(s).
 - b. When the operator proposes to set surface casing with Spudder Rig
 - i. Notify the BLM when moving in and removing the Spudder Rig.
 - ii. Notify the BLM when moving in the 2nd Rig. Rig to be moved in within 90 days of notification that Spudder Rig has left the location.
 - iii. BOP/BOPE test to be conducted per **43 CFR 3172** as soon as 2nd Rig is rigged up on well.
2. Floor controls are required for 3M or Greater systems. These controls will be on the rig floor, unobstructed, readily accessible to the driller and will be operational at all times during drilling and/or completion activities. Rig floor is defined as the area immediately around the rotary table; the area immediately above the substructure on which the draw works are located, this does not include the dog house or stairway area.

3. For intervals in which cement to surface is required, cement to surface should be verified with a visual check and density or pH check to differentiate cement from spacer and drilling mud. The results should be documented in the driller's log and daily reports.

A. CASING

1. Changes to the approved APD casing program need prior approval if the items substituted are of lesser grade or different casing size or are Non-API. The Operator can exchange the components of the proposal with that of superior strength (i.e. changing from J-55 to N-80, or from 36# to 40#). Changes to the approved cement program need prior approval if the altered cement plan has less volume or strength or if the changes are substantial (i.e. Multistage tool, ECP, etc.). The initial wellhead installed on the well will remain on the well with spools used as needed.
2. Wait on cement (WOC) for Potash Areas: After cementing but before commencing any tests, the casing string shall stand cemented under pressure until both of the following conditions have been met: 1) cement reaches a minimum compressive strength of 500 psi for all cement blends of both lead and tail cement, 2) until cement has been in place at least 8 hours. WOC time will be recorded in the driller's log. The casing integrity test can be done (prior to the cement setting up) immediately after bumping the plug.
3. Wait on cement (WOC) for Water Basin: After cementing but before commencing any tests, the casing string shall stand cemented under pressure until both of the following conditions have been met: 1) cement reaches a minimum compressive strength of 500 psi at the shoe, 2) until cement has been in place at least 8 hours. WOC time will be recorded in the driller's log. See individual casing strings for details regarding lead cement slurry requirements. The casing integrity test can be done (prior to the cement setting up) immediately after bumping the plug.
4. Provide compressive strengths including hours to reach required 500 pounds compressive strength prior to cementing each casing string. Have well specific cement details onsite prior to pumping the cement for each casing string.
5. No pea gravel permitted for remedial or fall back remedial without prior authorization from the BLM engineer.
6. On that portion of any well approved for a 5M BOPE system or greater, a pressure integrity test of each casing shoe shall be performed. Formation at the shoe shall be tested to a minimum of the mud weight equivalent anticipated to control the formation pressure to the next casing depth or at

total depth of the well. This test shall be performed before drilling more than 20 feet of new hole.

7. If hardband drill pipe is rotated inside casing, returns will be monitored for metal. If metal is found in samples, drill pipe will be pulled and rubber protectors which have a larger diameter than the tool joints of the drill pipe will be installed prior to continuing drilling operations.
8. Whenever a casing string is cemented in the R-111-Q potash area, the NMOCD requirements shall be followed.

B. PRESSURE CONTROL

1. All blowout preventer (BOP) and related equipment (BOPE) shall comply with well control requirements as described in **43 CFR 3172**.
2. If a variance is approved for a flexible hose to be installed from the BOP to the choke manifold, the following requirements apply: The flex line must meet the requirements of API 16C. Check condition of flexible line from BOP to choke manifold, replace if exterior is damaged or if line fails test. Line to be as straight as possible with no hard bends and is to be anchored according to Manufacturer's requirements. The flexible hose can be exchanged with a hose of equal size and equal or greater pressure rating. Anchor requirements, specification sheet and hydrostatic pressure test certification matching the hose in service, to be onsite for review. These documents shall be posted in the company man's trailer and on the rig floor.
3. 5M or higher system requires an HCR valve, remote kill line and annular to match. The remote kill line is to be installed prior to testing the system and tested to stack pressure.
4. If the operator has proposed a multi-bowl wellhead assembly in the APD. The following requirements must be met:
 - i. Wellhead shall be installed by manufacturer's representatives, submit documentation with subsequent sundry.
 - ii. If the welding is performed by a third party, the manufacturer's representative shall monitor the temperature to verify that it does not exceed the maximum temperature of the seal.
 - iii. Manufacturer representative shall install the test plug for the initial BOP test.
 - iv. Whenever any seal subject to test pressure is broken, all the tests in 43 CFR 3172.6(b)(9) must be followed.
 - v. If the cement does not circulate and one inch operations would have been possible with a standard wellhead, the well head shall be

cut off, cementing operations performed and another wellhead installed.

5. The appropriate BLM office shall be notified a minimum of 4 hours in advance for a representative to witness the tests.
 - i. In a water basin, for all casing strings utilizing slips, these are to be set as soon as the crew and rig are ready and any fallback cement remediation has been done. The casing cut-off and BOP installation can be initiated four hours after installing the slips, which will be approximately six hours after bumping the plug. For those casing strings not using slips, the minimum wait time before cut-off is eight hours after bumping the plug. BOP/BOPE testing can begin after cut-off or once cement reaches 500 psi compressive strength (including lead cement), whichever is greater. However, if the float does not hold, cut-off cannot be initiated until cement reaches 500 psi compressive strength (including lead when specified).
 - ii. In potash areas, for all casing strings utilizing slips, these are to be set as soon as the crew and rig are ready and any fallback cement remediation has been done. For all casing strings, casing cut-off and BOP installation can be initiated at twelve hours after bumping the cement plug. The BOPE test can be initiated after bumping the cement plug with the casing valve open. (only applies to single stage cement jobs, prior to the cement setting up.)
 - iii. The tests shall be done by an independent service company utilizing a test plug not a cup or J-packer and can be initiated immediately with the casing valve open. The operator also has the option of utilizing an independent tester to test without a plug (i.e. against the casing) pursuant to **43 CFR 3172** with the pressure not to exceed 70% of the burst rating for the casing. Any test against the casing must meet the WOC time for 8 hours or 500 pounds compressive strength, whichever is greater, prior to initiating the test (see casing segment as lead cement may be critical item).
 - iv. The test shall be run on a 5000 psi chart for a 2-3M BOP/BOP, on a 10000 psi chart for a 5M BOP/BOPE and on a 15000 psi chart for a 10M BOP/BOPE. If a linear chart is used, it shall be a one hour chart. A circular chart shall have a maximum 2 hour clock. If a twelve hour or twenty-four hour chart is used, tester shall make a notation that it is run with a two hour clock.
 - v. The results of the test shall be reported to the appropriate BLM office.

- vi. All tests are required to be recorded on a calibrated test chart. A copy of the BOP/BOPE test chart and a copy of independent service company test will be submitted to the appropriate BLM office.
- vii. The BOP/BOPE test shall include a low pressure test from 250 to 300 psi. The test will be held for a minimum of 10 minutes if test is done with a test plug and 30 minutes without a test plug. This test shall be performed prior to the test at full stack pressure.
- viii. BOP/BOPE must be tested by an independent service company within 500 feet of the top of the Wolfcamp formation if the time between the setting of the intermediate casing and reaching this depth exceeds 20 days. This test does not exclude the test prior to drilling out the casing shoe as per **43 CFR 3172**.

C. DRILLING MUD

Mud system monitoring equipment, with derrick floor indicators and visual and audio alarms, shall be operating before drilling into the Wolfcamp formation, and shall be used until production casing is run and cemented.

D. WASTE MATERIAL AND FLUIDS

All waste (i.e. drilling fluids, trash, salts, chemicals, sewage, gray water, etc.) created as a result of drilling operations and completion operations shall be safely contained and disposed of properly at a waste disposal facility. No waste material or fluid shall be disposed of on the well location or surrounding area. Porto-johns and trash containers will be on-location during fracturing operations or any other crew-intensive operations.

JS 2/20/2026

Sante Fe Main Office
Phone: (505) 476-3441

General Information
Phone: (505) 629-6116

Online Phone Directory
<https://www.emnrd.nm.gov/ocd/contact-us>

State of New Mexico
Energy, Minerals and Natural Resources
Oil Conservation Division
1220 S. St Francis Dr.
Santa Fe, NM 87505

CONDITIONS

Action 556558

CONDITIONS

Operator: MARATHON OIL PERMIAN LLC 600 W Illinois Ave Midland, TX 79701	OGRID: 372098
	Action Number: 556558
	Action Type: [C-103] NOI Change of Plans (C-103A)

CONDITIONS

Created By	Condition	Condition Date
ward.rikala	Any previous COA's not addressed within the updated COA's still apply.	3/3/2026