

N.M. Oil Cons. DIV-Dist. 2

1301 W. Grand Avenue

UNITED STATES
DEPARTMENT OF THE INTERIOR
BUREAU OF LAND MANAGEMENT
ALBUQUERQUE, NM 88210

FORM APPROVED
OMB No. 1004-0137
Expires: March 31, 2007

SUNDRY NOTICES AND REPORTS ON WELLS

Do not use this form for proposals to drill or to re-enter an abandoned well. Use Form 3160-3 (APD) for such proposals.

SUBMIT IN TRIPLICATE- Other instructions on reverse side.

1. Type of Well
 Oil Well Gas Well Other

RECEIVED

2. Name of Operator **CHESAPEAKE OPERATING, INC.** **LINDA GOOD** **MAY 17 2005**

3a Address **P.O. BOX 18496, OKLAHOMA CITY, OK 73154-0496** 3b. Phone No. (include area code) **405-767-4275**

4. Location of Well (Footage, Sec., T., R., M., or Survey Description)
660 FNL 2000 FWL NE NW SEC 24 T9S R25E

5. Lease Serial No.
NMNM 35158

6. If Indian, Allottee or Tribe Name

7. If Unit or CA/Agreement, Name and/or No.

8. Well Name and No.
JILL FEDERAL 2

9. API Well No.
30-005-63182

10. Field and Pool, or Exploratory Area
PECOS SLOPE SOUTH

11. County or Parish, State
CHAVES COUNTY, NEW MEXICO

12. CHECK APPROPRIATE BOX(ES) TO INDICATE NATURE OF NOTICE, REPORT, OR OTHER DATA

TYPE OF SUBMISSION	TYPE OF ACTION			
<input type="checkbox"/> Notice of Intent	<input type="checkbox"/> Acidize	<input type="checkbox"/> Deepen	<input type="checkbox"/> Production (Start/Resume)	<input type="checkbox"/> Water Shut-Off
<input checked="" type="checkbox"/> Subsequent Report	<input type="checkbox"/> Alter Casing	<input type="checkbox"/> Fracture Treat	<input type="checkbox"/> Reclamation	<input type="checkbox"/> Well Integrity
<input type="checkbox"/> Final Abandonment Notice	<input type="checkbox"/> Casing Repair	<input type="checkbox"/> New Construction	<input type="checkbox"/> Recomplete	<input checked="" type="checkbox"/> Other SITE FACILITY
	<input type="checkbox"/> Change Plans	<input type="checkbox"/> Plug and Abandon	<input type="checkbox"/> Temporarily Abandon	DIAGRAM
	<input type="checkbox"/> Convert to Injection	<input type="checkbox"/> Plug Back	<input type="checkbox"/> Water Disposal	

13. Describe Proposed or Completed Operation (clearly state all pertinent details, including estimated starting date of any proposed work and approximate duration thereof. If the proposal is to deepen directionally or recomplate horizontally, give subsurface locations and measured and true vertical depths of all pertinent markers and zones. Attach the Bond under which the work will be performed or provide the Bond No. on file with BLM/BIA. Required subsequent reports shall be filed within 30 days following completion of the involved operations. If the operation results in a multiple completion or recompletion in a new interval, a Form 3160-4 shall be filed once testing has been completed. Final Abandonment Notices shall be filed only after all requirements, including reclamation, have been completed, and the operator has determined that the site is ready for final inspection.)

PLEASE FIND ENCLOSED SITE FACILITY FOR JILL FEDERAL 2.

BLM NATIONWIDE BOND #NM2634.

(CHK PN 890025)

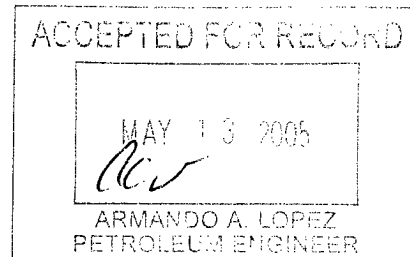

14. I hereby certify that the foregoing is true and correct
 Name (Printed/Typed) **LINDA GOOD** Title **PERMITTING AGENT**

Signature *Linda Good* Date **05/11/2005**

THIS SPACE FOR FEDERAL OR STATE OFFICE USE

Approved by _____ Title _____ Date _____
 Conditions of approval, if any, are attached. Approval of this notice does not warrant or certify that the applicant holds legal or equitable title to those rights in the subject lease which would entitle the applicant to conduct operations thereon. Office _____

Title 18 U.S.C. Section 1001 and Title 43 U.S.C. Section 1212, make it a crime for any person knowingly and willfully to make to any department or agency of the United States any false, fictitious or fraudulent statements or representations as to any matter within its jurisdiction.

CHESAPEAKE OPERATING, INC.

CHK Name & Number: JILL FEDERAL 2 890025
 API number: 30-005-63182
 County: CHAVES
 State: NM
 Field: PECOS SLOPE SOUTH
 Qtr Qtr Calls: E2 NE NW
 Sec/Twnshp/Rng: 24-9S-25E
 Number of Acres: 160

Regulatory Agency: BLM
 Lease Sign Type: FEDERAL
 CA#: 100% BLM Lease
 APD Lease #: NMNM 35158
 Federal/Indian: FEDERAL
 Last Violation: UNKNOWN
 District: PERMIAN
 Field Office: Hobbs

56 yds

General sealing of valves and sales by tank gauging. Production phase: all drain valves (D1) and sales valves (L1) sealed closed.
 Sales phase: the tank from which sales are being made will be isolated by sealing closed the drain, fill, and any equalizer valves during sales. Draining phase: the tank being drained will be isolated by sealing closed the sales, fill, equalizer valves and drain valves on the other tanks.



43 yds

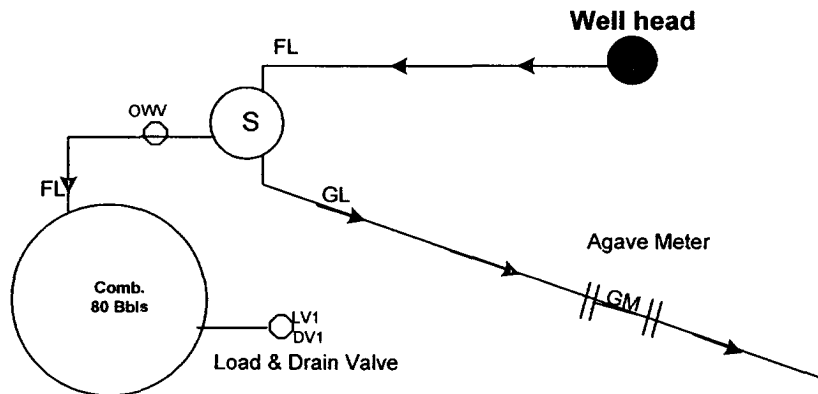

JILL FEDERAL 2_890025

Direction of Flow off Site: E

This lease is subject to
 Chesapeake's Site Security Plan
 located at 6100 N. Western
 Oklahoma City, OK 73118

Prepared by: DEBBIE HERNANDEZ
 Date: 8-17-04

Approved by:
 Date: