

Submit 3 Copies To Appropriate District Office
 District I
 1625 N. French Dr., Hobbs, NM 88240
 District II
 1301 W. Grand Ave., Artesia, NM 88210
 District III
 1000 Rio Brazos Rd., Aztec, NM 87410
 District IV
 1220 S. St. Francis Dr., Santa Fe, NM 87505

State of New Mexico
 Energy, Minerals and Natural Resources

Form C-103
 May 27, 2004

OIL CONSERVATION DIVISION
 1220 South St. Francis
 Santa Fe, NM 87505

WELL API NO.
 30-015-22040

5. Indicate Type of Lease
 STATE FEE

6. State Oil & Gas Lease No.

SUNDRY NOTICES AND REPORTS ON WELLS
 (DO NOT USE THIS FORM FOR PROPOSALS TO DRILL OR TO DEEPEN OR PLUG BACK TO A DIFFERENT RESERVOIR. USE "APPLICATION FOR PERMIT" (FORM C-101) FOR SUCH PROPOSALS.)

1. Type of Well: Oil Well Gas Well Other

7. Lease Name or Unit Agreement Name
 Andrew Arnquist Estate

8. Well Number 4

2. Name of Operator
 LEGACY RESERVES OPERATING LP

9. OGRID Number 240974

3. Address of Operator
 P. O. BOX 10848 MIDLAND, TEXAS 79702

10. Pool name or Wildcat
 Penasco Draw (YSRQSA)

4. Well Location
 Unit Letter H : 1650 feet from the North line and 430 feet from the East line
 Section 29 Township 18 S Range 26 E NMPM Eddy County

11. Elevation (Show whether DR, RKB, RT, GR, etc.)
 GL 3427' KB 3437'

Pit or Below-grade Tank Application or Closure

Pit type _____ Depth to Groundwater _____ Distance from nearest fresh water well _____ Distance from nearest surface water _____

Pit Liner Thickness: _____ mil Below-Grade Tank: Volume _____ bbls; Construction Material _____

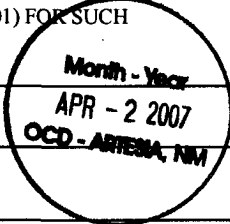

12. Check Appropriate Box to Indicate Nature of Notice, Report or Other Data

NOTICE OF INTENTION TO:		SUBSEQUENT REPORT OF:	
PERFORM REMEDIAL WORK <input type="checkbox"/>	PLUG AND ABANDON <input checked="" type="checkbox"/>	REMEDIAL WORK <input type="checkbox"/>	ALTERING CASING <input type="checkbox"/>
TEMPORARILY ABANDON <input type="checkbox"/>	CHANGE PLANS <input type="checkbox"/>	COMMENCE DRILLING OPNS. <input type="checkbox"/>	P AND A <input type="checkbox"/>
PULL OR ALTER CASING <input type="checkbox"/>	MULTIPLE COMPL <input type="checkbox"/>	CASING/CEMENT JOB <input type="checkbox"/>	
OTHER: <input type="checkbox"/>		OTHER: <input type="checkbox"/>	

13. Describe proposed or completed operations. (Clearly state all pertinent details, and give pertinent dates, including estimated date of starting any proposed work). SEE RULE 1103. For Multiple Completions: Attach wellbore diagram of proposed completion or recompletion.

SEE ATTACHED PROPOSED PROCEDURE.

I hereby certify that the information above is true and complete to the best of my knowledge and belief. I further certify that any pit or below-grade tank has been/will be constructed or closed according to NMOCD guidelines , a general permit or an (attached) alternative OCD-approved plan .

SIGNATURE X Danny M. Brock TITLE Production Superintendent DATE 3-27-07

Type or print name Danny M. Brock E-mail address: _____ Telephone No. 432-682-2516

For State Use Only

APPROVED BY: Phil Hankin TITLE FS DATE 4/3/07
 Conditions of Approval (if any): _____

P&A Procedure

Lease & Well #: Andrew Arnquist Estate Well No. 4

1. Call Artesia NMOCD 48 hrs. before commencing plugging operations @ 505-748-1283.
2. MIRUPU. Install BOP. POOH W/73 jts. 2-3/8" tbg (2228').
3. RIH and spot 35' plug of cement on CIBP @ 2315'. PU and circulate hole w/plugging mud. TIH and tag cement plug.
4. Pull up and spot 100' plug from 1218' - 1118'. TOH w/10 stands.
5. TIH and tag cement plug. Record depth. Insure hole is full of plugging mud.
6. Pull up and spot 100' cmt plug from 349' - 249'. TOH w/ tubing.
7. TIH and tag cement plug. Record depth. Insure hole is full of plugging mud.
8. Install 10 sack surface plug. 60'
9. Cut off wellhead and weld on P&A marker per NMOCD regulations.

PENASCO DRAW (YESO)

ANDREW ARNQUIST ESTATE WELL NO. 4

1650' FNL & 430' FEL
SECTION 29, T-18-S, R-26-E
EDDY COUNTY, NEW MEXICO

STATUS: SHUT-IN

TD: 2825' PBTB: 2776'

GL: 3427' KB: 3437'

SURFACE: 13-3/8", 48#, H-40 SET @ 299'.
CMT'D W/360 SX. CIRC TO SURFACE.

INTERMEDIATE: 9-5/8", 32.3', H-40 SET @ 1168'.
CMT'D W/700 SX. CIRC TO SURFACE.

PRODUCTION: 7", 23#, J-55 SET @ 2825'. CMT'D
W/700 SX. CIRC TO SURFACE.

TUBING: 73 JOINTS OF 2-3/8", 4.7#, J-55
LANDED @ 2825'

RODS:

PRESENT COMPLETION: YESO

2355', 72', 73', 80', 2403', 19', 21', 23', 33', 51',
53', 63', 67', 71', 73', 85', 2501', 75', 77', 79',
89', 91', 2614', 15', 19', 20', 21', 22', 31', 33',
35' W/1 SPF, 31 HOLES.

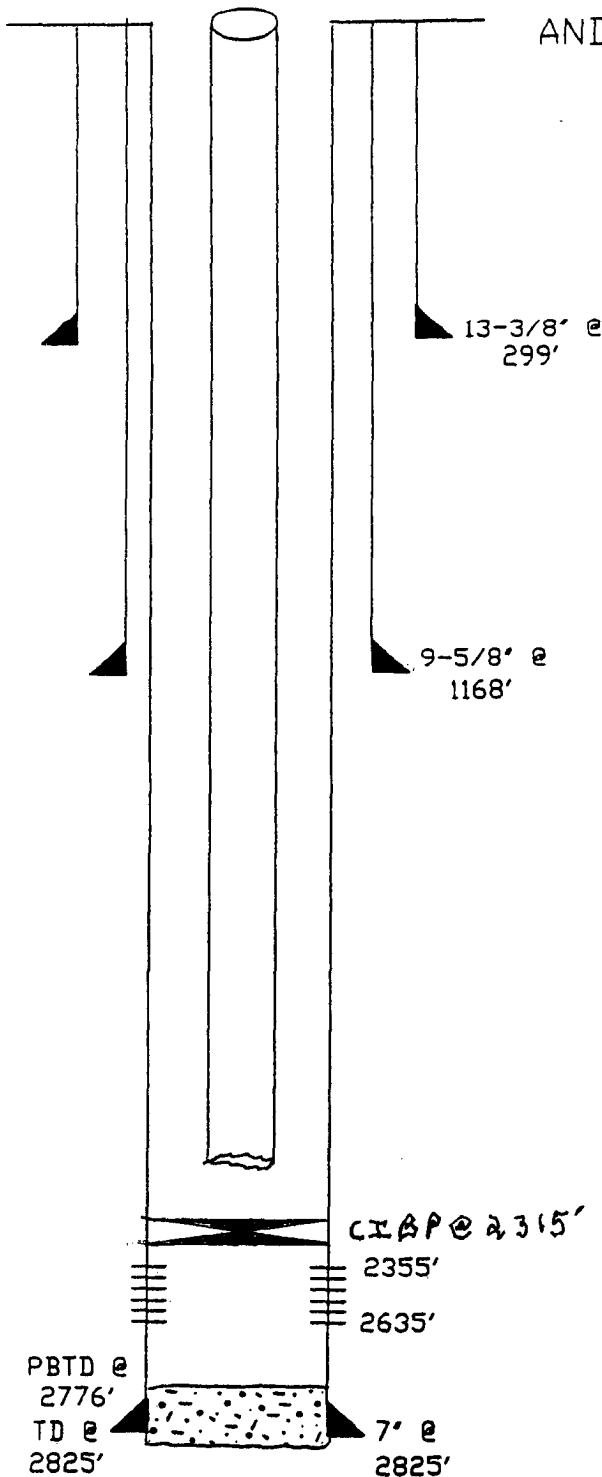

HISTORY: DRILLED IN MARCH, 1977. COMPLETED IN YESO F/2355'-2635'. A/5000 GALS.
F/40000 GALS, 12000# 100 MESH SD, & 54000# 20/40 SD. SHUT-IN AUGUST, 1986
AFTER PRODUCING 5 MBO, 17 MMCF, & 55 MBO FROM THE YESO.