

District I
1625 N. French Dr., Hobbs, NM 88240
District II
1301 W. Grand Avenue, Artesia, NM 88210
District III
1000 Rio Brazos Road, Aztec, NM 87410
District IV
1220 S. St. Francis Dr., Santa Fe, NM 87505

State of New Mexico
Energy Minerals and Natural Resources
Department
Oil Conservation Division
1220 South St. Francis Dr.
Santa Fe, NM 87505

Form C-144 CLEZ
July 21, 2008

For closed-loop systems that only use above ground steel tanks or haul-off bins and propose to implement waste removal for closure, submit to the appropriate NMOCD District Office.

Closed-Loop System Permit or Closure Plan Application

(that only use above ground steel tanks or haul-off bins and propose to implement waste removal for closure)

Type of action: Permit Closure

Instructions: Please submit one application (Form C-144 CLEZ) per individual closed-loop system request. For any application request other than for a closed-loop system that only use above ground steel tanks or haul-off bins and propose to implement waste removal for closure, please submit a Form C-144.

Please be advised that approval of this request does not relieve the operator of liability should operations result in pollution of surface water, ground water or the environment. Nor does approval relieve the operator of its responsibility to comply with any other applicable governmental authority's rules, regulations or ordinances.

1.
Operator: Clayton Williams Energy, Inc. OGRID #: 25706
Address: Suite 3000, 6 Desta Drive, Midland, Texas 79705
Facility or well name: Phillips -19- Federal #21
API Number: 31-015- 38156 OCD Permit Number: 210759
U/L or Qtr/Qtr B Section 19 Township 17-S Range 29-E County: Eddy
Center of Proposed Design: Latitude 32.826308 N Longitude 104.110464 NAD: 1927 1983
Surface Owner: Federal State Private Tribal Trust or Indian Allotment

2.
 Closed-loop System: Subsection H of 19.15.17.11 NMAC
Operation: Drilling a new well Workover or Drilling (Applies to activities which require prior approval of a permit or notice of intent) P&A
 Above Ground Steel Tanks or Haul-off Bins

3.
Signs: Subsection C of 19.15.17.11 NMAC
 12"x 24", 2" lettering, providing Operator's name, site location, and emergency telephone numbers
 Signed in compliance with 19.15.3.103 NMAC

4.
Closed-loop Systems Permit Application Attachment Checklist: Subsection B of 19.15.17.9 NMAC
Instructions: Each of the following items must be attached to the application. Please indicate, by a check mark in the box, that the documents are attached.
 Design Plan - based upon the appropriate requirements of 19.15.17.11 NMAC
 Operating and Maintenance Plan - based upon the appropriate requirements of 19.15.17.12 NMAC
 Closure Plan (Please complete Box 5) - based upon the appropriate requirements of Subsection C of 19.15.17.9 NMAC and 19.15.17.13 NMAC
 Previously Approved Design (attach copy of design) API Number: _____
 Previously Approved Operating and Maintenance Plan API Number: _____

5.
Waste Removal Closure For Closed-loop Systems That Utilize Above Ground Steel Tanks or Haul-off Bins Only: (19.15.17.13.D NMAC)
Instructions: Please indentify the facility or facilities for the disposal of liquids, drilling fluids and drill cuttings. Use attachment if more than two facilities are required.
Disposal Facility Name: Controlled Recovery, Inc. Disposal Facility Permit Number: NM-01-0006
Disposal Facility Name: Lea Land, LLC Disposal Facility Permit Number: WM-1-035
Will any of the proposed closed-loop system operations and associated activities occur on or in areas that will not be used for future service and operations?
 Yes (If yes, please provide the information below) No
Required for impacted areas which will not be used for future service and operations:
 Soil Backfill and Cover Design Specifications -- based upon the appropriate requirements of Subsection H of 19.15.17.13 NMAC
 Re-vegetation Plan - based upon the appropriate requirements of Subsection I of 19.15.17.13 NMAC
 Site Reclamation Plan - based upon the appropriate requirements of Subsection G of 19.15.17.13 NMAC

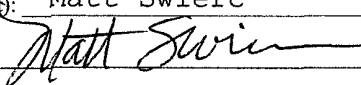
6.
Operator Application Certification:
I hereby certify that the information submitted with this application is true, accurate and complete to the best of my knowledge and belief.
Name (Print): Matt Swierc Title: Production Superintendent
Signature:  Date: 5/19/10
e-mail address: MSwierc@claytonwilliams.com Telephone: (432) 682-6324

7. **OCD Approval:** Permit Application (including closure plan) Closure Plan (only)

OCD Representative Signature: *Ricardo R. Dado* Approval Date: 09/21/2010

Title: *Asst. J. Supervisor* OCD Permit Number: 210759

8. **Closure Report (required within 60 days of closure completion):** Subsection K of 19.15.17.13 NMAC

Instructions: Operators are required to obtain an approved closure plan prior to implementing any closure activities and submitting the closure report. The closure report is required to be submitted to the division within 60 days of the completion of the closure activities. Please do not complete this section of the form until an approved closure plan has been obtained and the closure activities have been completed.

Closure Completion Date: _____

9. **Closure Report Regarding Waste Removal Closure For Closed-loop Systems That Utilize Above Ground Steel Tanks or Haul-off Bins Only:**

Instructions: Please identify the facility or facilities for where the liquids, drilling fluids and drill cuttings were disposed. Use attachment if more than two facilities were utilized.

Disposal Facility Name: _____ Disposal Facility Permit Number: _____

Disposal Facility Name: _____ Disposal Facility Permit Number: _____

Were the closed-loop system operations and associated activities performed on or in areas that *will not* be used for future service and operations?

Yes (If yes, please demonstrate compliance to the items below) No

Required for impacted areas which will not be used for future service and operations:

Site Reclamation (Photo Documentation)

Soil Backfilling and Cover Installation

Re-vegetation Application Rates and Seeding Technique

10. **Operator Closure Certification:**

I hereby certify that the information and attachments submitted with this closure report is true, accurate and complete to the best of my knowledge and belief. I also certify that the closure complies with all applicable closure requirements and conditions specified in the approved closure plan.

Name (Print): _____ Title: _____

Signature: _____ Date: _____

e-mail address: _____ Telephone: _____

CLAYTON WILLIAMS ENERGY, INC.

CLOSED-LOOP DESIGN PLAN

Clayton Williams Energy, Inc. ("CWEI") shall design and construct its closed-loop system closed-loop system to ensure the confinement of oil, gas or water to prevent uncontrolled releases.

The design plan for the closed-loop system shall use appropriate engineering principles and practices and follow applicable manufacturers' requirements. The plan shall include operating and maintenance procedures and a closure plan, as set out below. For further information on the closed-loop system design, please see the attached diagram.

CWEI's closed loop system will not use a drying pad, temporary pit, below grade tank or sump. It will use an aboveground haul-off bin suitable for holding solids and fluids from rig operations. No fencing will be constructed around the closed-loop system. Signage shall be posted per the C-144 form to which this plan is attached.

CLOSED-LOOP OPERATING AND MAINTENANCE PLAN

CWEI shall operate and maintain the closed-loop system in a manner that will contain solids and liquids, maintain the system's integrity, prevent contamination of fresh water and protect public health and the environment. To attain this goal, the following procedures will be followed:

1. CWEI shall recycle, reuse or reclaim or dispose of all drilling fluids in a manner approved by NMOCD rules.
2. CWEI shall not discharge into or store any hazardous waste in the closed-loop system, including the haul-off bin, nor shall it allow miscellaneous solid waste or debris into same.
3. The haul-off bin will be of sufficient volume to maintain a safe freeboard prior to disposal of the solids and liquids from rig operations. Disposal will be done on a periodic basis, whenever a haul-off bin is determined to be at full volume capacity. The solids and liquids in the closed-loop system will be transported off the drill site and disposed at the NMOCD-permitted disposal facility or facilities listed below. The designated NMOCD-permitted disposal facility is:

Disposal Facility:	NMOCD Permit No.:
Controlled Recovery, Inc.	NM-01-0006
Lea Land, LLC	WM-1-035

4. The closed-loop system will be inspected at least daily while the drilling or workover rig is on-site. CWEI shall maintain a log of such inspections.
5. If some component of the closed-loop system develops a leak, or if any penetration of a component occurs below the liquid's surface, then CWEI shall promptly remove all liquid above the damage or leak line, notify the appropriate NMOCD district office within 48 hours of the discovery and repair the damage or replace the affected closed-loop system component.

CLOSED-LOOP CLOSURE PLAN

The closure for this drill site is not subject to the closure requirements for temporary pits specified in Subsection B of 19.15.17.13, NMAC, as CWEI will not use any temporary pits in conjunction with its closed-loop system. The closure for this drill site is not subject to the closure requirements for closed-loop systems using drying pads specified in Subsection D of 19.15.17.13, NMAC, as CWEI will not use any drying pads in conjunction with its closed-loop system. Further, the closed-loop system operations and associated activities will all be performed on the drilling pad, and will not be performed on or in areas that will not be used for future service and operations. The closure for the closed-loop system at this site will be performed as follows:

1. Immediately following termination of rig operations, all solids and liquids remaining in the closed-loop system will be transported in the haul-off bin or bins to the NMOCD-permitted facility(ies) listed above.
2. The closed-loop system components, including any and all haul-off bins, will be removed from the location in conjunction with the move of the drilling or completion rig from the well site.
3. Within six months from the date that CWEI releases the drilling or workover rig, CWEI will complete and execute items 9 and 10 of the attached C-144 CLEZ and file same with the appropriate NMOCD district office.

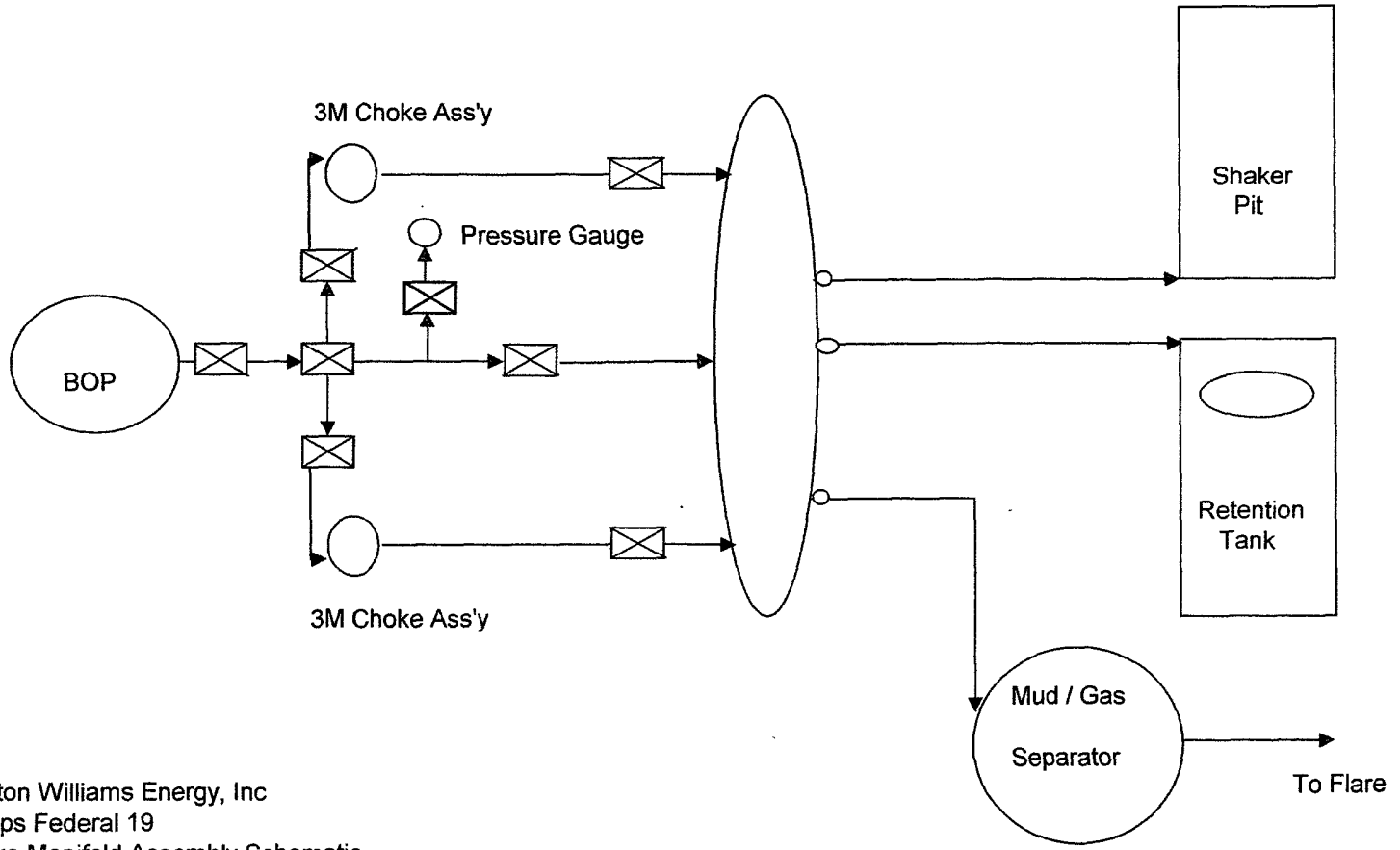

Clayton Williams Energy, Inc
 Phillips Federal 19
 Choke Manifold Assembly Schematic
 Connection to Closed Looping Mud System
 3M psi Rating