

Nadel and Gussman Permian Kodiak State No. 1

MINIMUM BLOWOUT PREVENTER REQUIREMENTS

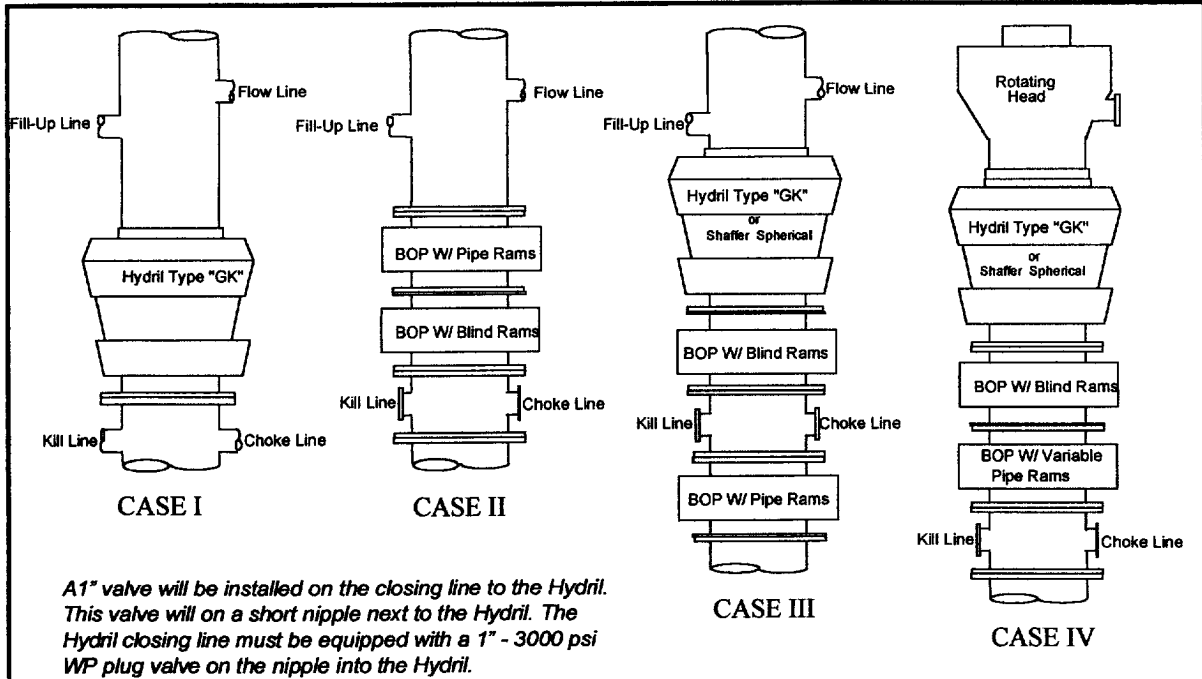

A1" valve will be installed on the closing line to the Hydril. This valve will be on a short nipple next to the Hydril. The Hydril closing line must be equipped with a 1" - 3000 psi WP plug valve on the nipple into the Hydril.

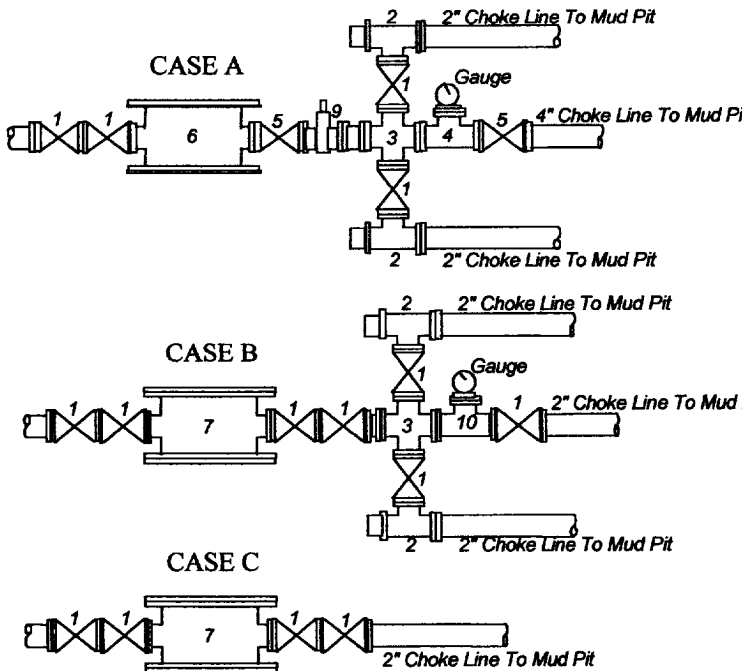

BOP SIZE	BOP CASE	WORKING PRESSURE	CHOKE CASE
13-5/8	II	3000	A
11	III	5000	A

***Rotating head required**

Bradenhead : _____
Mfr: _____
Size: _____ Type: _____

Legend

1. 2" flanged all steel valve must be either Cameron "F", Halliburton Low Torque or Shaffer Flo-Seal.
2. 2" flanged adjustable chokes, min. 1" full opening & equipped with hard trim.
3. 4" x 2" flanged steel cross.
4. 4" flanged steel tee.
5. 4" flanged all steel valve (Type as in no. 1).
6. Drilling Spool with 2" x 4" flanged outlet.
7. Drilling Spool with 2" x 2" flanged outlet.
8. 2" x 2" flanged steel cross.
9. 4" pressure operated gate valve.
10. 2" flanged steel tee.

Notes

Choke manifold may be located in any convenient position. Use all steel fittings throughout. Make 90° turns with bull plugged tees only. No field welding will be permitted on any of the components of the choke manifold and related equipment upstream of the chokes. The choke spool and all lines and fittings must be at least equivalent to the test pressure of the preventers required. Independent closing control unit with clearly marked controls to be located on derrick floor near driller's position.