

UNITED STATES  
DEPARTMENT OF THE INTERIOR  
BUREAU OF LAND MANAGEMENT

131

SUNDRY NOTICES AND REPORTS ON WELLS

Do not use this form for proposals to drill or to deepen or reentry to a different reservoir.  
Use "APPLICATION FOR PERMIT—" for such proposals

SUBMIT IN TRIPLICATE

1. Type of Well  
 Oil Well  Gas Well  Other  
2. Name of Operator  
MYCO INDUSTRIES, INC.  
3. Address and Telephone No.  
207 S 4th, ARTESIA, NM 88210  
4. Location of Well (Footage, Sec., T., R., M., or Survey Description)  
990' FNL & 990' FEL Sec. 10-T22S-R28E

RECEIVED  
AUG 31 '94  
O.C.D.  
ARTESIA OFFICE

5. Lease Designation and Serial No.  
LC060613  
6. If Indian, Allottee or Tribe Name  
7. If Unit or CA, Agreement Designation  
BIG EDDY UNIT  
8. Well Name and No.  
BIG EDDY UNIT # 106  
9. API Well No.  
30-015-25150  
10. Field and Pool, or Exploratory Area  
E. INDIAN DRAW DELAWARE  
11. County or Parish, State  
EDDY, NM

12. CHECK APPROPRIATE BOX(S) TO INDICATE NATURE OF NOTICE, REPORT, OR OTHER DATA

TYPE OF SUBMISSION	TYPE OF ACTION
<input checked="" type="checkbox"/> Notice of Intent	<input checked="" type="checkbox"/> Abandonment
<input type="checkbox"/> Subsequent Report	<input type="checkbox"/> Recompletion
<input type="checkbox"/> Final Abandonment Notice	<input type="checkbox"/> Plugging Back
	<input type="checkbox"/> Casing Repair
	<input type="checkbox"/> Altering Casing
	<input type="checkbox"/> Other _____
	<input type="checkbox"/> Change of Plans
	<input type="checkbox"/> New Construction
	<input type="checkbox"/> Non-Routine Fracturing
	<input type="checkbox"/> Water Shut-Off
	<input type="checkbox"/> Conversion to Injection
	<input type="checkbox"/> Dispose Water

(Note: Report results of multiple completion on Well Completion or Recompletion Report and Log form.)

13. Describe Proposed or Completed Operations (Clearly state all pertinent details, and give pertinent dates, including estimated date of starting any proposed work. If well is directionally drilled, give subsurface locations and measured and true vertical depths for all markers and zones pertinent to this work.)\*

PROPOSED TO P/A PER ATTACHED PROCEDURES.

CERTIFIED RETURNED: P 083 922 909

14. I hereby certify that the foregoing is true and correct  
Signed Sheldon Moreno Title ENGINEERING TECHNICIAN Date 8/10/94  
(This space for Federal or State office use)  
Approved by (ORIG. SGD.) JOE G. LARA Title PETROLEUM ENGINEER Date 8/30/94  
Conditions of approval, if any:

Title 18 U.S.C. Section 1001, makes it a crime for any person knowingly and willfully to make to any department or agency of the United States any false, fictitious or fraudulent statements or representations as to any matter within its jurisdiction.

\*See Instruction on Reverse Side

MYCO INDUSTRIES, INC.

BIG EDDY #106  
 LC 060613 API # 30-015-25150  
 990' FNL | 990' FEL, UNIT A  
 S10-T22S-R28E, NMPM  
 EDDY CO., E. INDIAN DRAW DELAWARE

RFUD: 1-3-85  
 COMP: 2-26-85

TOPS:

DELAWARE - 2628'  
 CHERRY CAN - 3658'  
 BONE SPRINGS - 6062'

PIA:

- (A) FOLLOW ATTACHED CONDITIONS OF APPROVAL PUBLISHED BY CARLSBAD BLM (NOT DATED BY BLM - NO REF.)
- (B) 24-HR NOTICE
- (C) LOAD HOLE W/ MUD LADEN FLUID
- (D) CIBP @ 5490'± W/ 15-SXS
- (E) CIBP @ 3600'± W/ 15-SXS
- (F) PERF. @ 450'
- (F) CMT. SQ. REST. @ 440'  
 CMT TO SURF IN/OUT 5 1/2"  
 (IF UNABLE TO SQZ. TO SURF  
 WILL PUT CMT MIN TOP 50' IN/OUT)
- (G) REG. MKR @ SURFACE
- (H) RESTORE PER BLM SPECS.

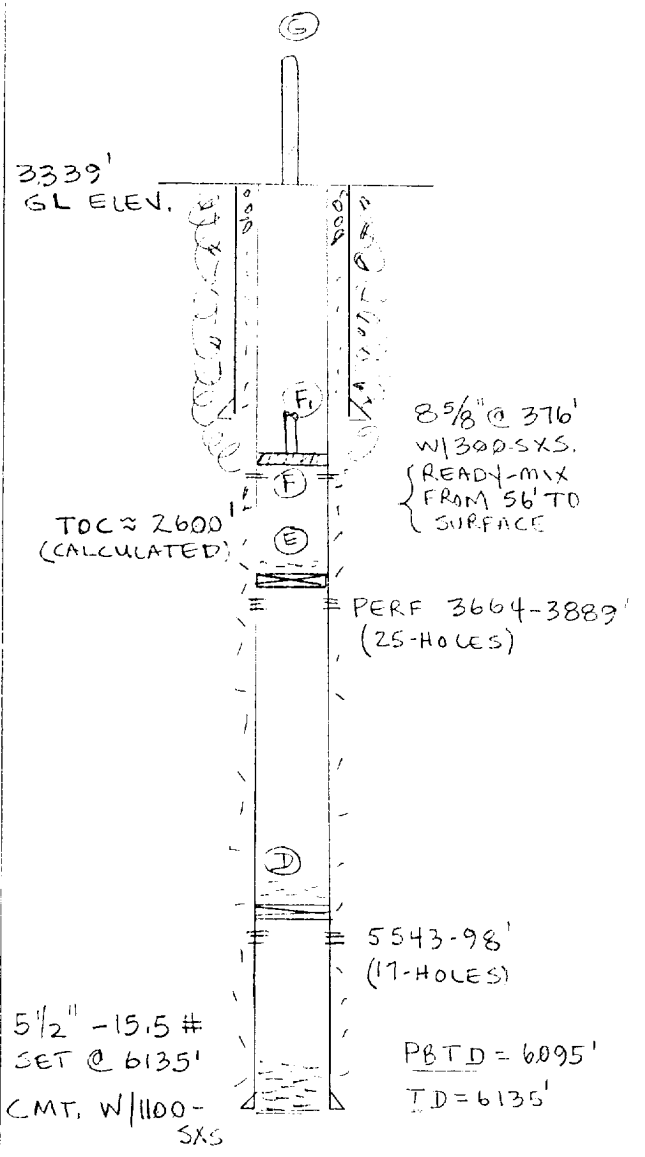

4300 W. INDIAN DRAW  
 DELAWARE  
 302-338-1111  
 NATIONAL

BUREAU OF LAND MANAGEMENT  
CARLSBAD RESOURCE AREA

Permanent Abandonment of Wells on Federal Lands

Conditions of Approval

1. Approval: Plugging operations shall commence within 90 days from the approval date of plugging procedure.
2. Notification: Contact the appropriated BLM office at least 24 hours prior to the commencing of any plugging operations. For wells in Eddy county call (505) 234-5272; for wells in Lea County call (505) 393-3612.
3. Blowout Preventers: A blowout preventer (BOP), as appropriate, shall be installed before commencing any plugging operation. The minimum BOP requirement is a 2M system for a well not deeper than 9,090 feet; a 3M system for a well not deeper than 13,636 feet; and a 5M system for a well not deeper than 22,727 feet.
4. Mud Requirement: Mud shall be placed between all plugs. Minimum consistency of plugging mud shall be obtained by mixing at the rate of 25 sacks (50 pounds each) of gel per 100 barrels of water. Minimum nine (9) pounds per gallon.
5. Cement Requirement: Sufficient cement shall be used to bring any required plug to the specified depth and length. Any given cement volumes on the proposed plugging procedure are merely estimates and are not final.

Unless otherwise specified in the approved procedure, the cement plug shall consist of either class "C", for up to 7,500 feet of depth, mixed at 14.8 lbs./gal. with 6.3 gallons of fresh water per sack or class "H", for deeper than 7,500 feet plugs, mixed at 16.4 lbs./gal. with 4/3 gallons of fresh water per sack.

6. Dry Hole Marker: All casing shall be cut-off at the base of the cellar or 3 feet below final restored ground level (whichever is deeper). The well bore shall then be capped with a 4-inch pipe, 10-feet in length, 4 feet above ground and embedded in cement. The following information shall be permanently inscribed on the dry hole marker: Well name and number, the name of the operator, the lease serial number, the surveyed location (the quarter-quarter section, section, township and range or other authorized survey designation acceptable to the authorized officer; such as metes and bounds.)
7. Subsequent Plugging Reporting: Within 30 days after plugging work is completed, file one original and five copies of the Subsequent Report of Abandonment, Form 3160-5 to BLM. The report should give in detail the manner in which the plugging work was carried out, the extent (by depths) of cement plugs placed, and the size and location (by depths) of casing left in the well. Show date well was plugged.

Following the submittal and approval of the Subsequent Report of Abandonment, surface restoration conditions of approval will be developed and furnished to you.