

**UNORTHODOX
LOCATION**

OCD Artesia

ATS-14-178

FORM APPROVED
OMB No. 1004-0137
Expires October 31, 2014

UNITED STATES
DEPARTMENT OF THE INTERIOR
BUREAU OF LAND MANAGEMENT

APPLICATION FOR PERMIT TO DRILL OR REENTER

5. Lease Serial No.
NM-019612, NM-017225B, NM-035607

6. If Indian, Allottee or Tribe Name

1a. Type of work: DRILL REENTER

7. If Unit or CA Agreement, Name and No.

1b. Type of Well: Oil Well Gas Well Other Single Zone Multiple Zone

8. Lease Name and Well No.
RDX FEDERAL COM 28-2H <40485>

2. Name of Operator RKI EXPLORATION & PRODUCTION, LLC.

9. API Well No.

3a. Address 210 PARK AVENUE, SUITE 900
OKLAHOMA CITY, OKLAHOMA 73102

3b. Phone No. (include area code)
(405) 987-2138 (JOEL ACOSTA)

10. Field and Pool, or Exploratory
UNDESIGNATED BONE SPRING
WCB-03-26306K/B.S.

4. Location of Well (Report location clearly and in accordance with any State requirements.)*

At surface 330 FNL & 840 FWL, SECTION 28
At proposed prod. zone 230 FSL & 395 FWL, SECTION 33

11. Sec., T. R. M. or Blk. and Survey or Area
SHL: SECTION 28, T. 26 S., R. 30 E.
BHL: SECTION 33, T. 26 S., R. 30 E. <97863>

14. Distance in miles and direction from nearest town or post office*
15 MILES SOUTHEAST OF MALAGA, NM

12. County or Parish
EDDY

13. State
NM

15. Distance from proposed*
location to nearest
property or lease line, ft.
(Also to nearest drig. unit line, if any)

SHL: 330'
BHL: 230'

16. No. of acres in lease
SHL: 1160
BHL: 290.72

17. Spacing Unit dedicated to this well
225.61

18. Distance from proposed location*
to nearest well, drilling, completed,
applied for, on this lease, ft.

SHL: 150'
BHL: 530'

19. Proposed Depth
TVD: 7590'
MD: 14,264'

20. BLM/BIA Bond No. on file
NLM-NMB-000460

21. Elevations (Show whether DF, KDB, RT, GL, etc.)
3005' GL

22. Approximate date work will start*
ASAP

23. Estimated duration
25 DAYS

24. Attachments

The following, completed in accordance with the requirements of Onshore Oil and Gas Order No.1, must be attached to this form:

- 1. Well plat certified by a registered surveyor.
- 2. A Drilling Plan.
- 3. A Surface Use Plan (if the location is on National Forest System Lands, the SUPO must be filed with the appropriate Forest Service Office).
- 4. Bond to cover the operations unless covered by an existing bond on file (see Item 20 above).
- 5. Operator certification
- 6. Such other site specific information and/or plans as may be required by the BLM.

25. Signature *Barry W. Hunt* Name (Printed/Typed) BARRY W. HUNT Date 11/5/13

Title PERMIT AGENT FOR RKI EXPLORATION & PRODUCTION, LLC.

Approved by (Signature) *IS/STEPHEN J. CAFFEY* Name (Printed/Typed) Office CARLSBAD FIELD OFFICE Date MAR 28 2014

Title FIELD MANAGER Office CARLSBAD FIELD OFFICE

Application approval does not warrant or certify that the applicant holds legal or equitable title to those rights in the subject lease which would entitle the applicant to conduct operations thereon.
Conditions of approval, if any, are attached.

APPROVAL FOR TWO YEARS

Title 18 U.S.C. Section 1001 and Title 43 U.S.C. Section 1212, make it a crime for any person knowingly and willfully to make to any department or agency of the United States any false, fictitious or fraudulent statements or representations as to any matter within its jurisdiction.

(Continued on page 2)

Operator must be in compliance with NMOCD Rule 5.9 prior to producing well
OCD

*(Instructions on page 2)
Carlsbad Controlled Water Basin

Approval Subject to General Requirements & Special Stipulations Attached

SEE ATTACHED FOR
CONDITIONS OF APPROVAL

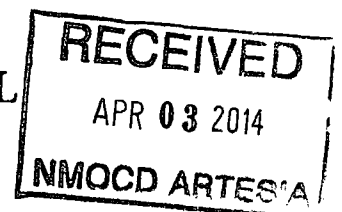

CERTIFICATION

I hereby certify that I, or persons under my direct supervision, have inspected the proposed drill site and access road proposed herein; that I am familiar with the conditions that presently exist; that I have full knowledge of State and Federal laws applicable to this operation; that the statements made in this APD package are, to the best of my knowledge, true and correct, and that the work associated with the operations proposed herein will be performed in conformity with this APD package and the terms and conditions under which it is approved. I also certify that I, or RKI Exploration and Production, LLC am responsible for the operations conducted under this application. These statements are subject to the provisions of 18 U. S. C. 1001 for the filing of false statements. Executed this 11th day of November 2013.

Signed: _____

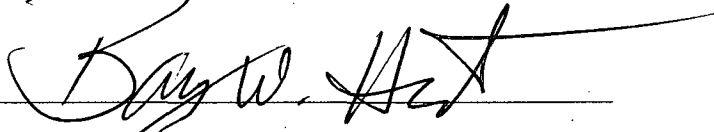
A handwritten signature in black ink, appearing to read "Barry W. Hunt", is written over a horizontal line. The signature is stylized and cursive.

Printed Name: Barry Hunt

Position: Agent for RKI Exploration & Production, LLC.

Address: 1403 Springs Farm Place, Carlsbad, NM 88220

Telephone: (575) 361-4078

E-mail: specialtpermitting@gmail.com

DISTRICT I
1625 N. French Dr., Hobbs, NM 88240
Phone: (575) 393-6161 Fax: (575) 393-0720

DISTRICT II
811 S. First St., Artesia, NM 88210
Phone: (575) 748-1283 Fax: (575) 748-9720

DISTRICT III
1000 Rio Tercero Rd., Aztec, NM 87410
Phone: (505) 334-6179 Fax: (505) 334-6170

DISTRICT IV
1220 S. St. Francis Dr., Santa Fe, NM 87505
Phone: (505) 476-3460 Fax: (505) 476-3462

State of New Mexico
Energy, Minerals & Natural Resources Department
OIL CONSERVATION DIVISION
1220 South St. Francis Dr.
Santa Fe, New Mexico 87505

Form C-102
Revised August 1, 2011
Submit one copy to appropriate
District Office
 AMENDED REPORT

WELL LOCATION AND ACREAGE DEDICATION PLAT

API Number 30-015-42276	Pool Code 97863	Pool Name UNDESIGNATED BONE SPRING
Property Code 40485	Property Name RDX FEDERAL COM 28	Well Number 2H
OGRID No. 246289	Operator Name RKI EXPLORATION & PRODUCTION	Elevation 3005'

Surface Location

UL or lot no.	Section	Township	Range	Lot Idn	Feet from the	North/South line	Feet from the	East/West line	County
D	28	26 S	30 E		330	NORTH	840	WEST	EDDY

Bottom Hole Location If Different From Surface

UL or lot no.	Section	Township	Range	Lot Idn	Feet from the	North/South line	Feet from the	East/West line	County
4	33	26 S	30 E		230	SOUTH	395	WEST	EDDY

Dedicated Acres	Joint or Infill	Consolidated Code	Order No.
224.74			

No allowable will be assigned to this completion until all interests have been consolidated or a non-standard unit has been approved by the division.

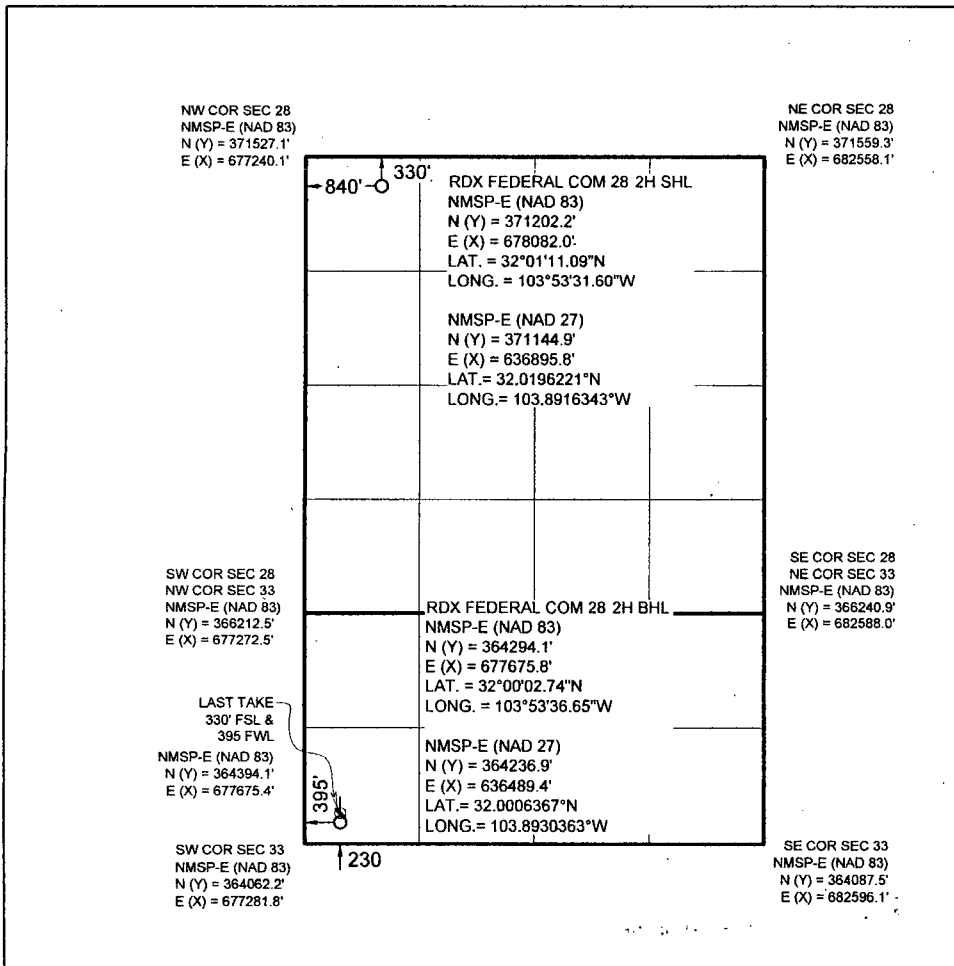

OPERATOR CERTIFICATION

I hereby certify that the information contained herein is true and complete to the best of my knowledge and belief, and that this organization either owns a working interest or unleased mineral interest in the land including the proposed bottom hole location or has a right to drill this well at this location pursuant to a contract with an owner of such a mineral or working interest, or to voluntary pooling agreement or a compulsory pooling order heretofore entered by the division.

Barry Hunt 2/12/14
Signature Date

BARRY HUNT
Print Name

specialtpermitting@gmail.com
E-mail Address

SURVEYORS CERTIFICATION

I hereby certify that the well location shown on this plat was plotted from field notes of actual surveys made by me or under my supervision, and that the same is true and correct to the best of my belief.

April 25, 2013 Revised 02-11-14
Date of Survey

Signature and Seal of Professional Surveyor

James E. Tompkins
James E. Tompkins
Professional Surveyor

Job No.: WTC48881
JAMES E. TOMPKINS 14729
Certificate Number

SITE LOCATION

SEC 21, T. 26 S., R. 30 E.
 SEC 28, T. 26 S., R. 30 E.

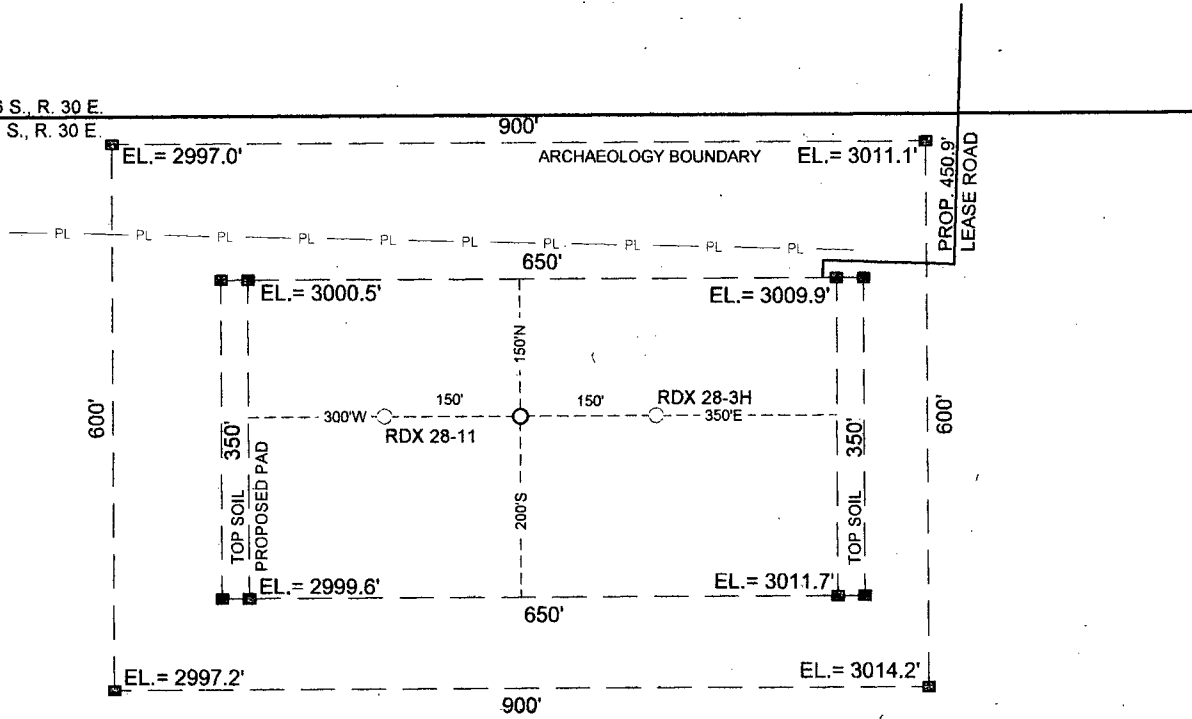

RDX FEDERAL COM 28-2H SHL
 NMSP-E (NAD 83)
 N (Y) = 371202.2'
 E (X) = 678082.0'
 LAT. = 32°01'11.09"N
 LONG. = 103°53'31.60"W

NMSP-E (NAD 27)
 N (Y) = 371144.8'
 E (X) = 636895.8'
 LAT. = 32.0196221°N
 LONG. = 103.8916343°W

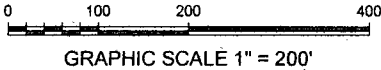

SECTION 28, T 26 S, R 30 E, N.M.P.M.

COUNTY: EDDY STATE: NM

DESCRIPTION: 330' FNL & 840' FWL

OPERATOR: RKI EXPLORATION & PRODUCTION

WELL NAME: RDX FEDERAL COM 28-2H

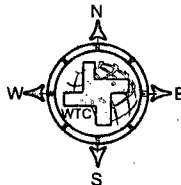

DRIVING DIRECTIONS:

From Stateline Road and County Road 1, go 9.5 miles west.
 Turn right and go 1.1 miles and the location flag is on the left.

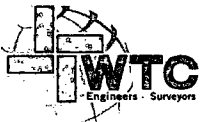

WEST TEXAS CONSULTANTS, INC.
 ENGINEERS PLANNERS SURVEYORS
 405 S.W. 1st. STREET
 ANDREWS, TEXAS 79714
 (432) 523-2181

RKI EXPLORATION & PRODUCTION

JOB No.: WTC48881

LOCATION VERIFICATION MAP

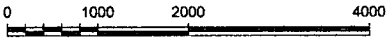
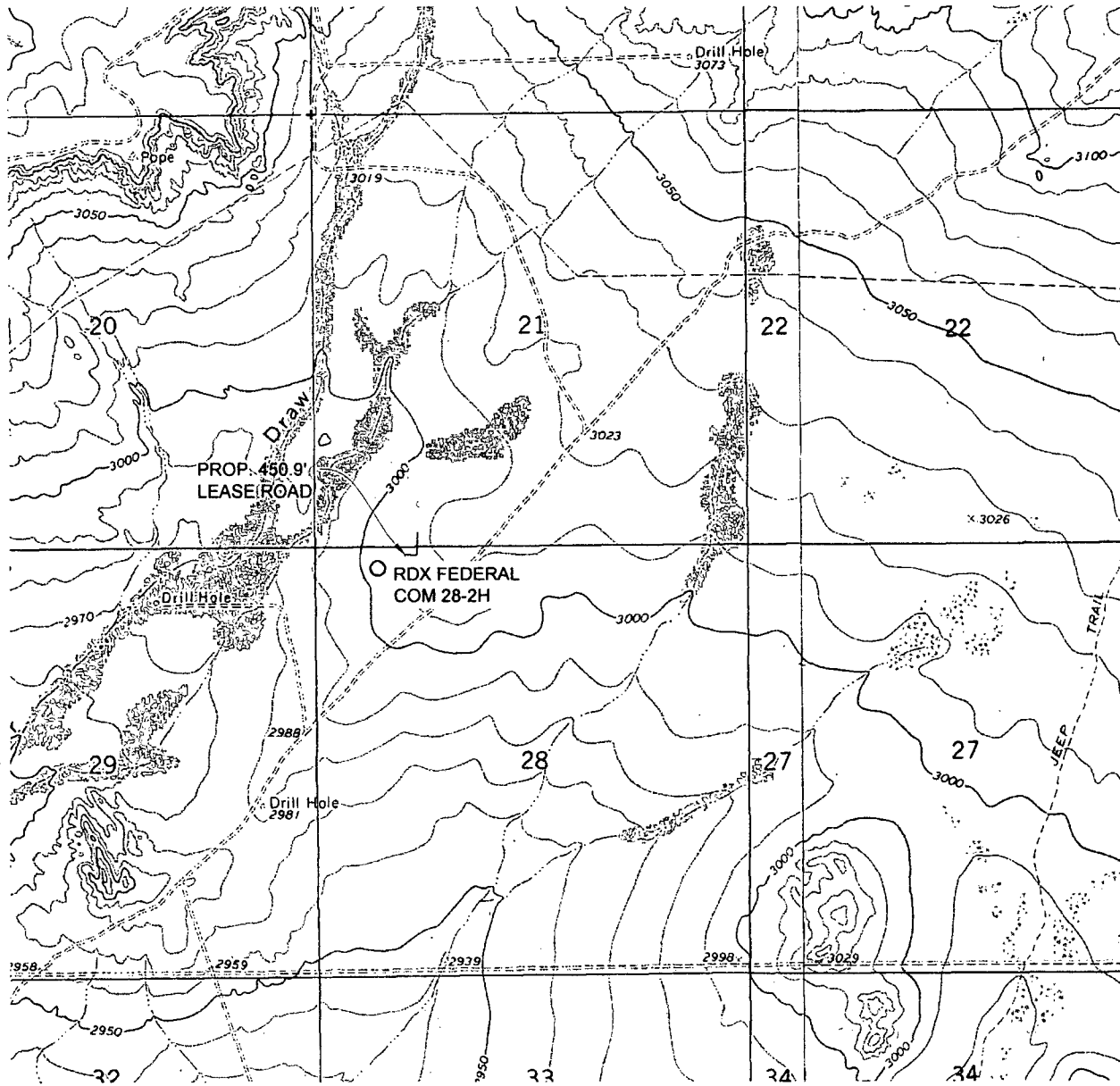

GRAPHIC SCALE 1" = 2000'

SECTION 28, T 26 S, R 30 E, N.M.P.M.

COUNTY: EDDY STATE: NM

DESCRIPTION: 330' FNL & 840' FWL

OPERATOR: RKI EXPLORATION & PRODUCTION

WELL NAME: RDX FEDERAL COM 28-2H

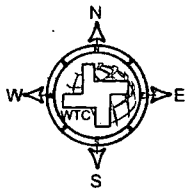

DRIVING DIRECTIONS:

From Stateline Road and County Road 1, go 9.5 miles west.
Turn right and go 1.1 miles and the location flag is on the left.

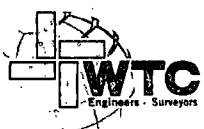

WEST TEXAS CONSULTANTS, INC.
ENGINEERS PLANNERS SURVEYORS
405 S.W. 1st STREET
ANDREWS, TEXAS 79714
(432) 523-2181

RKI EXPLORATION & PRODUCTION

JOB No.: WTC48881

Z:\Projects\WTC & RKI\Surveying\WTC-48881-RI-Exploration_Site & Plot 12.RD* 25.mxd\Drawings\ESB1-RI-28-21.dwg

AERIAL MAP

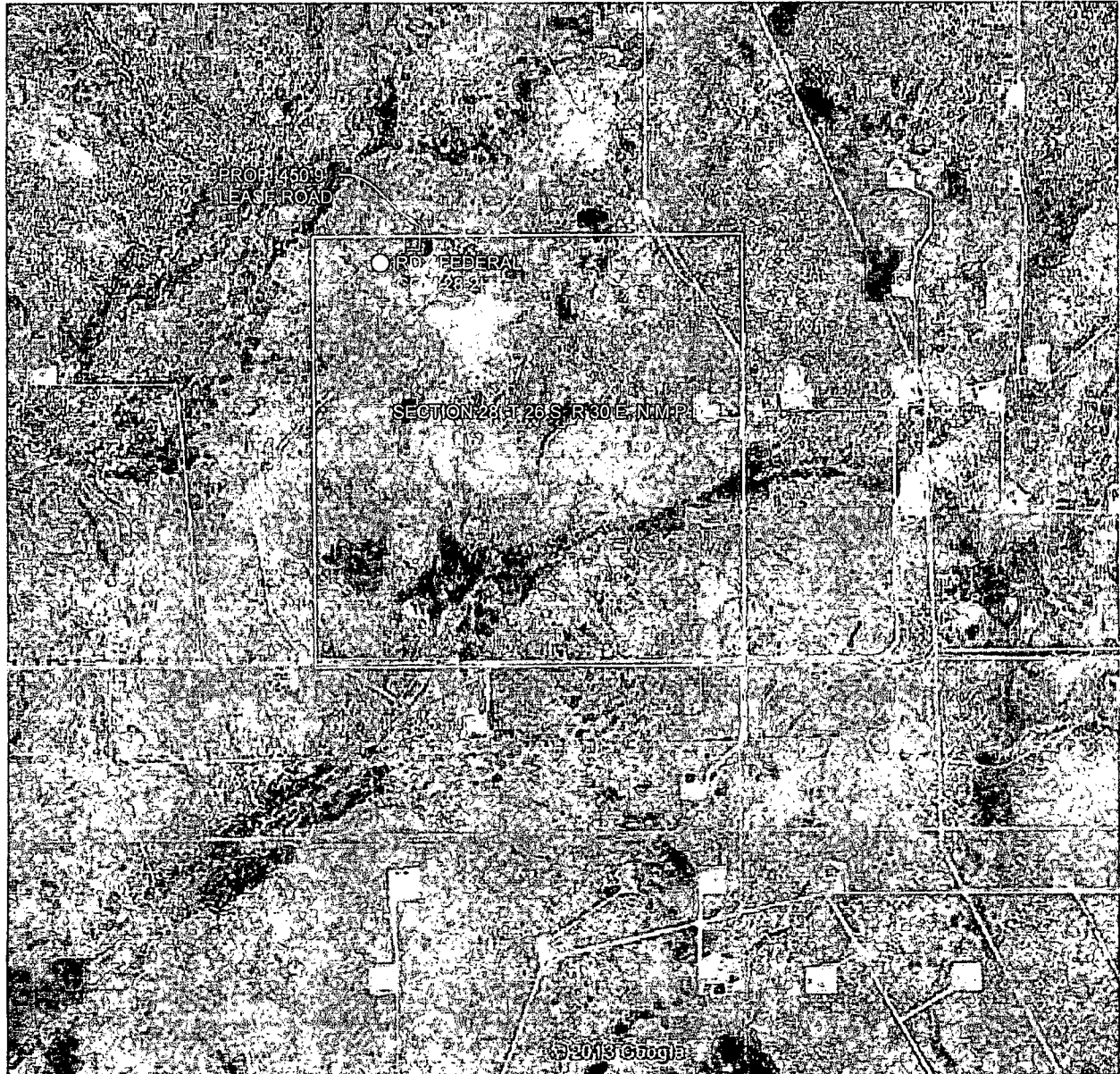

0 1000 2000 4000

GRAPHIC SCALE 1" = 2000'

SECTION 28, T 26 S, R 30 E, N.M.P.M.

COUNTY: EDDY STATE: NM

DESCRIPTION: 330' FNL & 840' FWL

OPERATOR: RKI EXPLORATION & PRODUCTION

WELL NAME: RDX FEDERAL COM 28-2H

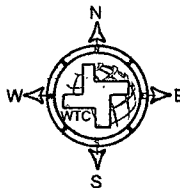

DRIVING DIRECTIONS:

From Stateline Road and County Road 1, go 9.5 miles west.
Turn right and go 1.1 miles and the location flag is on the left.

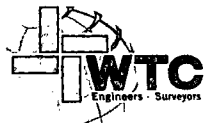

WEST TEXAS CONSULTANTS, INC.
ENGINEERS PLANNERS SURVEYORS
405 S.W. 1st STREET
ANDREWS, TEXAS 79714
(432) 523-2181

RKI EXPLORATION & PRODUCTION

JOB No.: WTC48881

VICINITY MAP

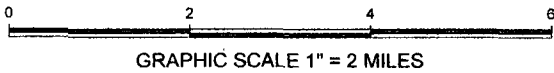
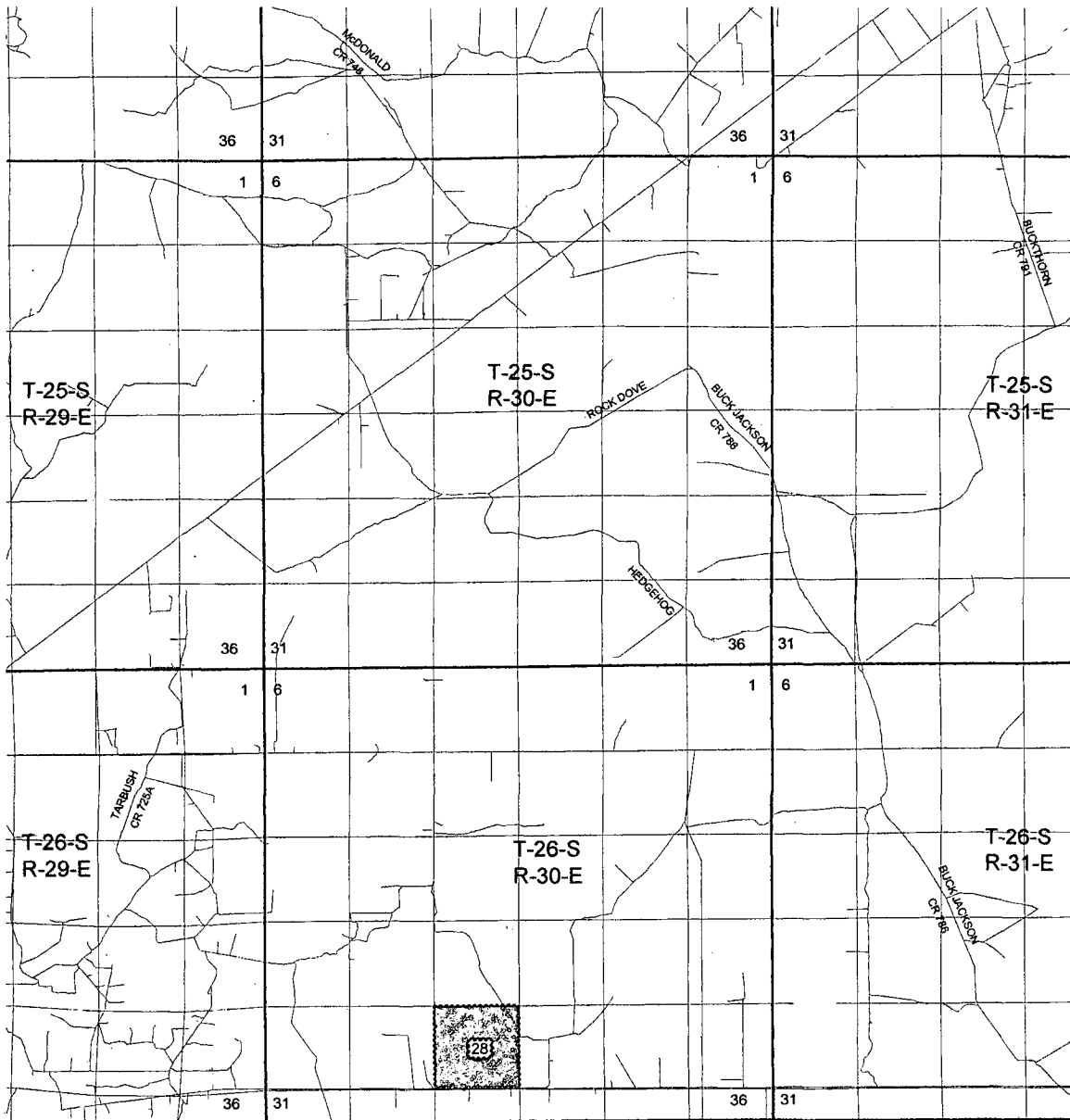

SECTION 28, T 26 S, R 30 E, N.M.P.M.

COUNTY: EDDY STATE: NM

DESCRIPTION: 330' FNL & 840' FWL

OPERATOR: RKI EXPLORATION & PRODUCTION

WELL NAME: RDX FEDERAL COM 28-2H

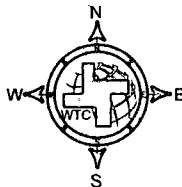

DRIVING DIRECTIONS:

From Stateline Road and County Road 1, go 9.5 miles west. Turn right and go 1.1 miles and the location flag is on the left.

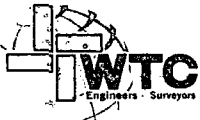

WEST TEXAS CONSULTANTS, INC.
ENGINEERS PLANNERS SURVEYORS
405 S.W. 1st STREET
ANDREWS, TEXAS 79714
(432) 523-2181

RKI EXPLORATION & PRODUCTION

JOB No.: WTC48881

Exhibit A

Access

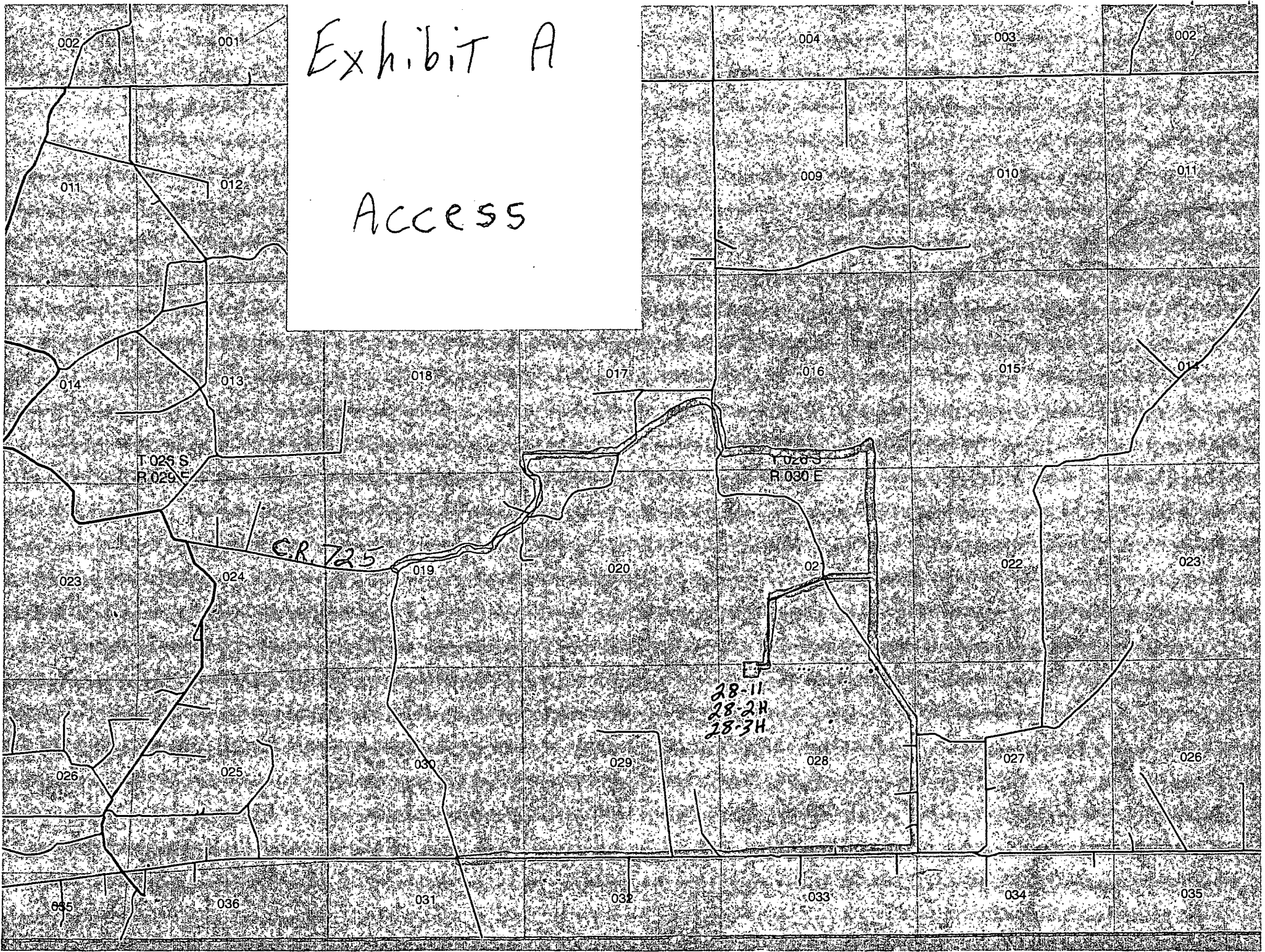
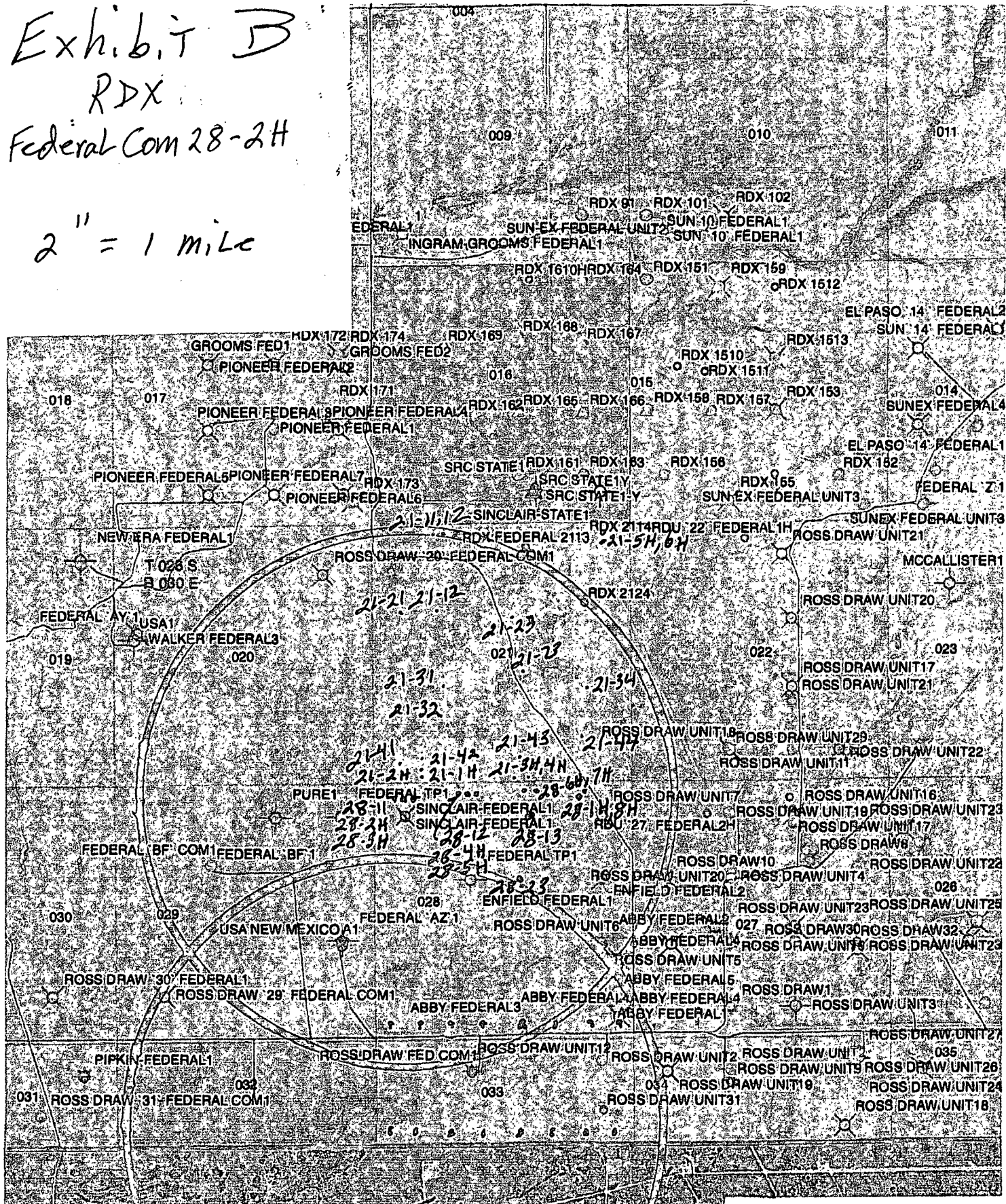

Exhibit B
RDX
Federal Com 28-2H

2" = 1 mile



TEXAS

Exhibit E

SITE LOCATION

SEC 21, T. 26 S., R. 30 E.
 SEC 28, T. 26 S., R. 30 E.

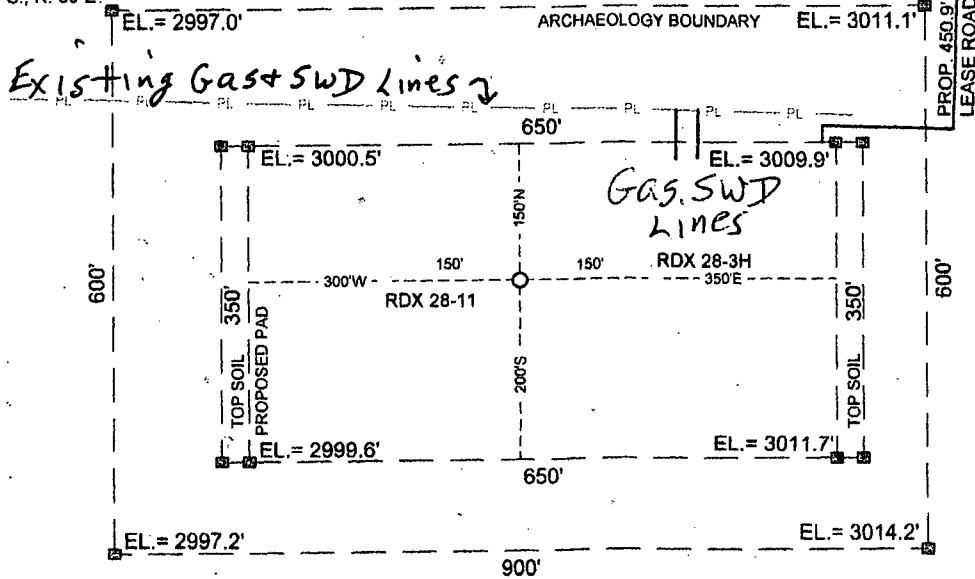

RDX FEDERAL COM 28-2H SHL
 NMSP-E (NAD 83)
 N (Y) = 371202.2'
 E (X) = 878082.0'
 LAT. = 32°01'11.08"N
 LONG. = 103°53'31.60"W

NMSP-E (NAD 27)
 N (Y) = 371144.8'
 E (X) = 836895.8'
 LAT. = 32.0188221°N
 LONG. = 103.8916343°W

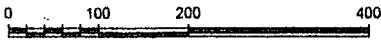

GRAPHIC SCALE 1" = 200'

SECTION 28, T 26 S, R 30 E, N.M.P.M.

COUNTY: EDDY STATE: NM

DESCRIPTION: 330' FNL & 840' FWL

OPERATOR: RKI EXPLORATION & PRODUCTION

WELL NAME: RDX FEDERAL COM 28-2H

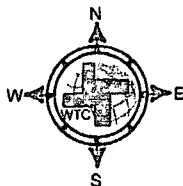

DRIVING DIRECTIONS:

From Stateline Road and County Road 1, go 9.5 miles west. Turn right and go 1.1 miles and the location flag is on the left.



WEST TEXAS CONSULTANTS, INC.
 ENGINEERS PLANNERS SURVEYORS
 405 S.W. 1st. STREET
 ANDREWS, TEXAS 79714
 (432) 523-2181

RKI EXPLORATION & PRODUCTION

JOB No.: WTC48881

Exhibit F

SECTION 28, TOWNSHIP 26 SOUTH, RANGE 30 EAST, N.M.P.M., EDDY CO., NM.

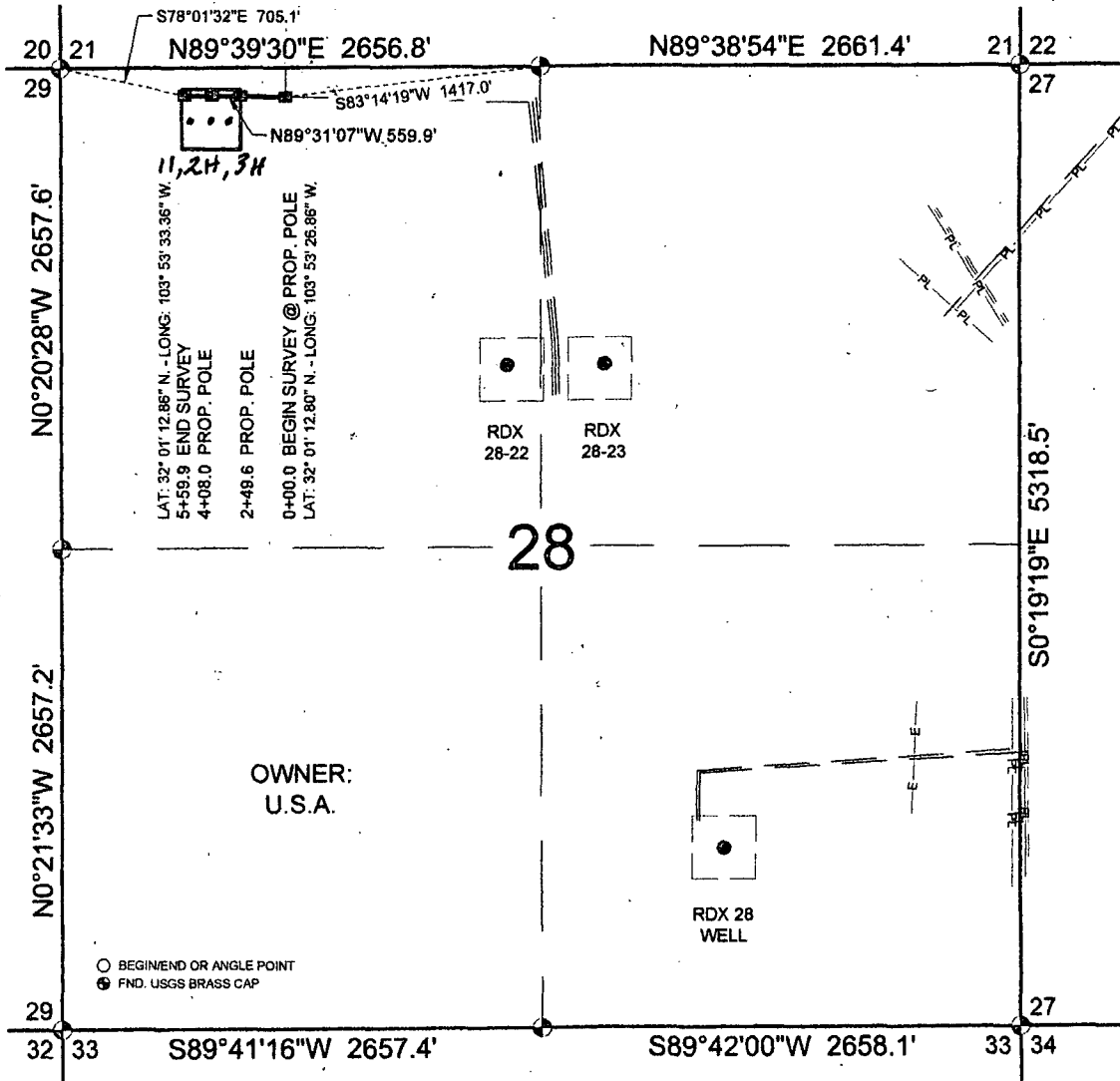

OWNER:
U.S.A.

A STRIP OF LAND 30 FEET IN WIDTH AND 559.9 FEET, 0.11 MILE OR 33.93 RODS IN LENGTH, SITUATED IN SECTIONS 28, TOWNSHIP 26 SOUTH, RANGE 30 EAST, N.M.P.M., EDDY COUNTY, NEW MEXICO, AND BEING 15 FEET LEFT AND 15 FEET RIGHT OF THE SURVEY OF CENTERLINE AS SHOWN HEREON.

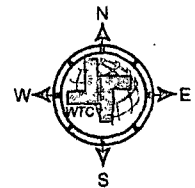

NOTE:
1. BASIS OF BEARING IS A TRANSVERSE MERCATOR PROJECTION OF THE NEW MEXICO STATE PLANE COORDINATE SYSTEM, EAST ZONE, NAD 83.

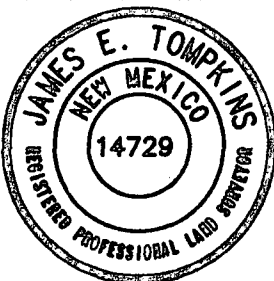

I, JAMES E. TOMPKINS, NEW MEXICO PROFESSIONAL SURVEYOR NO. 14729, DO HEREBY CERTIFY THAT THIS PLAT AND THE ACTUAL SURVEY ON THE GROUND UPON WHICH IT IS BASED WERE PERFORMED BY ME OR UNDER MY DIRECT SUPERVISION; THAT I AM RESPONSIBLE FOR THIS SURVEY; THAT THIS SURVEY MEETS THE MINIMUM STANDARDS FOR SURVEYING IN NEW MEXICO; AND THAT IT IS TRUE AND CORRECT TO THE BEST OF MY KNOWLEDGE AND BELIEF.

James E. Tompkins
 JAMES E. TOMPKINS, N.M. P.L.S.
 SURVEY DATE: 11/06/2013
 JOB NO.: 49436
 11/08/2013
 No. 14729
 DRAFT FH
 SHEET: 1 OF 1

RKI EXPLORATION & PRODUCTION
 A PROPOSED POWER LINE IN
 SECTION 28, T26S, R30E, N.M.P.M.,
 EDDY COUNTY, NEW MEXICO



WEST TEXAS CONSULTANTS, INC.
 ENGINEERS PLANNERS SURVEYORS
 405 S.W. 1st Street
 Andrews, TX 79714
 (432) 523-2181

DRILLING PLAN

Well RDX Federal Com 28-2H
 Location Surface: 330 FNL 840 FEL Sec. 28-26S-30E
 Bottom Hole: 230 FSL 395 FEL Sec. 33-26S-30E
 County Eddy
 State New Mexico

- 1) The elevation of the unprepared ground is 3,005 feet above sea level.
- 2) The geologic name of the surface formation is Quaternary - Alluvium.
- 3) A rotary rig will be utilized to drill the well to 14,264 feet and run casing & cement. This equipment will then be rigged down and the well will be completed with a workover rig.
- 4) Proposed depth is 14,264 feet.

5) Estimated tops:

	MD	TVD		
Rustler	800	800		
Salado	1,100	1,100		
Castile	1,650	1,650		
Lamar Lime	3,498	3,498		
Base of Lime	3,523	3,523		
Delaware Top	3,564	3,564		
Bell Canyon Sand	3,564	3,564	Oil	1,568 psi
Cherry Canyon Sand	4,621	4,621	Oil	2,033 psi
Brushy Canyon Sand	5,670	5,670	Oil	2,495 psi
KOP	7,017	7,017	Oil	3,087 psi
Bone Spring Lime	7,350	7,329	Oil	3,234 psi
Landing Point (Avalon Shale)	7,917	7,590	Oil	3,340 psi
TD	14,264	7,590		3,340 psi

BHP = .44 psi/ft x depth

146 degree F

Water anticipated at 180 feet.

6) Pressure control equipment:

The blowout preventer equipment (BOP) shown in Exhibit #1 will consist of a double ram type (3,000 psi WP) preventer, a bag-type annular preventer (3,000 psi WP), and rotating head. Both units will be hydraulically operated and the ram type preventer will be equipped with blind rams on top and pipe rams (sized to accommodate the drill pipe size being utilized) on bottom. A 13 3/8" SOW x 13 5/8" 3M multi-bowl casing head will be installed on the 13 3/8" casing and utilized until total depth is reached. All BOP and associated equipment will be tested to 3,000 psi and the annular will be tested to 1,500 psi after initial installation. The 13 3/8" and 9 5/8" casing will be tested to .22 psi per ft of casing string length or 1,500 psi whichever is greater, but not to exceed 70% of the minimum yield.

The 9 5/8" casing will be hung in the casing multi-bowl head and the stack will not be nipped down at this point. The stack will not be isolated and tested after running the 9 5/8" casing; but will be tested along with the 9 5/8" casing. Pipe rams will be operated and checked each 24 hour period and each time the drill string is out of the hole. These function test will be documented on the daily driller's log.

A drilling spool or blowout preventer with 2 side outlets (choke side shall be 3" minimum diameter, kill side shall be at least 2" diameter).

2 kill line valves, one of which will be a check valve.

2 chokes on the manifold along with a pressure gauge.

Upper kelly cock valve with handle available.

Safety valve and subs to fit all drill string connections in use.

All BOP equipment connections subjected to pressure will be flanged, welded, or clamped.

Fill up line above the upper most preventer.

See COA

7) Casing program: ALL NEW CASING

See COA

Hole Size	Top	Bottom	OD Csg	Wt/Grade	Connection	Collapse Design Factor	Burst Design Factor	Tension Design Factor
17 1/2"	0	950 785'	13 3/8"	54.5#/J-55	ST&C	2.70	13.06	9.93
12 1/4"	0	3,500 3375'	9 5/8"	40#/J-55	LT&C	1.31	5.13	3.71
8 3/4"	0	14,264	5 1/2"	17#/HCP-110	LT&C	2.46	1.55	4.98
Collapse	1.125							
Burst	1.0							
Tension	2.0							

8) Cement program:

Surface	17.1/2" hole
Pipe OD	13 3/8" 785'
Setting Depth	950 ft
Annular Volume	0.69462 cf/ft
Excess	1
	100 %
Lead	604 sx
Tail	200 sx
	1.74
	1.34
	cf/sk
	cf/sk
	13.5 ppg
	14.8 ppg
Lead:	"C" + 4% PF20 gel + 2% PF1 CC + .125 pps PF29 Cellophane + .25 ps PF46 defoamer
Tail:	"C" + 1% PF1 CC

Top of cement: Surface

Intermediate	12 1/4" hole
Pipe OD	9 5/8" 3375'
Setting Depth	3,500 ft
Annular Volume	0.31318 cf/ft
Excess	0.5
	0.3627 cf/ft
	50 %
Lead	685 sx
Tail	200 sx
	1.92 cf/sk
	1.33 cf/sk
	12.9 ppg
	14.8 ppg
Lead:	35/65 Poz/C + 5% PF44 salt + 6% PF20 gel + 3 pps PF42 Kolite + .125 pps PF29 Cellophane + 0.4 pps PF46 defoamer + 1% PF1 CC
Tail:	"C" + .2% PF13 retarder

Top of cement: Surface

Production	8 3/4" hole
Pipe OD	5 1/2"
Setting Depth	14,264 ft
Annular Volume	0.2526 cf/ft
Excess	0.28
DV Tool Depth	5,500 ft
	0.26074 cf/ft
	28 %
Stage 1	
Lead:	376 sx
Tail:	1,097 sx
	2.08 cf/sk
	1.87 cf/sk
	11.5 ppg
	13.0 ppg
Lead:	PVL + .5% CC + .3% PF79 extender + .25 pps PF46 defoamer + 3 pps PF42 Kolite + .125 pps PF29 Cellophane + .2% PF13 retarder
Tail:	PVL + 30% PF151 calcium carbonate + .5% PF174 expanding agent + .7% PF606 gel suppressing agent + .2% PF153 antisepting agent + .25 pps PF46 antifoam + .2% PF13 retarder
Top of cement:	DV tool

Stage 2	
Lead:	272 sx
Tail:	175 sx
	1.89 cf/sk
	1.33 cf/sk
	12.9 ppg
	14.8 ppg
Lead:	35/65 Poz "C" + 5% PF44 salt + 6% PF20 gel + .125 pps PF29 cellophane + .25 pps PF46 antifoam + .2% PF13 retarder
Tail:	"C" + .2% PF13 retarder
Top of cement:	3,200 ft

See COA

9) Mud program:

See
COA

Top	Bottom	Mud Wt.	Vis	Fluid Loss	Type System
0	950 725	8.5 to 8.9	32 to 36	NC	Fresh Water
950	3,500 3315	9.8 to 10.0	28 to 30	NC	Brine
3,500	14,264	8.9 to 9.1	28 to 36	NC	Fresh Water

The necessary mud products for weight addition and fluid loss control will be on location at all times. Electronic pit monitoring equipment will be utilized with a Pason system. Electronic mud monitoring and mud logging will be utilized below the 9 5/8" casing.

10) Logging, coring, and testing program:

No drill stem test are planned

Total depth to intermediate: CNL, Caliper, GR, DLL,

Intermediate to surface: CNL, GR

No coring is planned

11) Potential hazards:

No abnormal pressure or temperature is expected. No H2S is known to exist in the area, although some form of H2S detection equipment will be utilized. If H2S is encountered the operator will comply with the provisions of Onshore Order No. 6. Lost circulation is not anticipated, but lost circulation material and weighting materials will be on location and readily available.

12) Anticipated start date

ASAP

Duration

25 days

RKI EXPLORATION								RIG:	
WELL:		RDX Federal Com 28-2H (Eddy, NM)			Target Direction:		183.37 deg		
LOCATION:		330' FNL & 840' FWL 28-26S-30E			North/South Hard Line:		330		
BHL:		230' FSL & 395' FWL 33-26S-30E			East/West Hard Line:		2,245		
STATION	SURVEY					VERT.	DLS/100		
NUMBER	DEPTH	INC	AZMTH	TVD	N-S	E-W	SECTION		
Tie-In									
1									
2	1000.0			1000					
3	2000.0			2000					
4	3000.0			3000					
5	4000.0			4000					
6	5000.0			5000					
7	6000.0			6000					
8	7000.0			7000					
KOP	7017.0			7017					
10	7117.0	10.00	183.37	7116	-9	-1	9	10.0	
11	7217.0	20.00	183.37	7213	-34	-2	35	10.0	
12	7317.0	30.00	183.37	7303	-77	-5	77	10.0	
13	7417.0	40.00	183.37	7385	-134	-8	134	10.0	
14	7517.0	50.00	183.37	7456	-204	-12	205	10.0	
15	7617.0	60.00	183.37	7513	-286	-17	286	10.0	
16	7717.0	70.00	183.37	7555	-376	-22	377	10.0	
17	7817.0	80.00	183.37	7581	-473	-28	473	10.0	
EOC	7917.0	90.00	183.37	7590	-572	-34	573	10.0	
19	8017.0	90.00	183.37	7590	-672	-40	673		
20	8645.0	90.00	183.37	7590	-1299	-76	1301		
21	8745.0	90.00	183.37	7590	-1399	-82	1401		
22	8845.0	90.00	183.37	7590	-1498	-88	1501		
23	8945.0	90.00	183.37	7590	-1598	-94	1601		
24	9000.0	90.00	183.37	7590	-1653	-97	1656		
25	9250.0	90.00	183.37	7590	-1903	-112	1906		
26	9500.0	90.00	183.37	7590	-2152	-127	2156		
27	9750.0	90.00	183.37	7590	-2402	-141	2406		
28	10000.0	90.00	183.37	7590	-2651	-156	2656		
29	10250.0	90.00	183.37	7590	-2901	-171	2906		
30	10500.0	90.00	183.37	7590	-3151	-186	3156		
31	10750.0	90.00	183.37	7590	-3400	-200	3406		
32	11000.0	90.00	183.37	7590	-3650	-215	3656		
33	11250.0	90.00	183.37	7590	-3899	-230	3906		
34	11500.0	90.00	183.37	7590	-4149	-244	4156		
35	11750.0	90.00	183.37	7590	-4398	-259	4406		
36	12000.0	90.00	183.37	7590	-4648	-274	4656		
37	12250.0	90.00	183.37	7590	-4897	-288	4906		
38	12500.0	90.00	183.37	7590	-5147	-303	5156		
39	12750.0	90.00	183.37	7590	-5397	-318	5406		
40	13000.0	90.00	183.37	7590	-5646	-332	5656		
41	13250.0	90.00	183.37	7590	-5896	-347	5906		
42	13500.0	90.00	183.37	7590	-6145	-362	6156		
43	13750.0	90.00	183.37	7590	-6395	-377	6406		
44	14000.0	90.00	183.37	7590	-6644	-391	6656		
45	14250.0	90.00	183.37	7590	-6894	-406	6906		
TD	14264.0	90.00	183.37	7590	-6908	-407	6920		

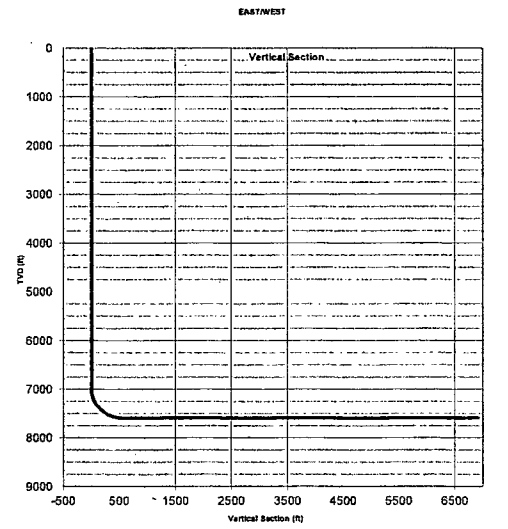
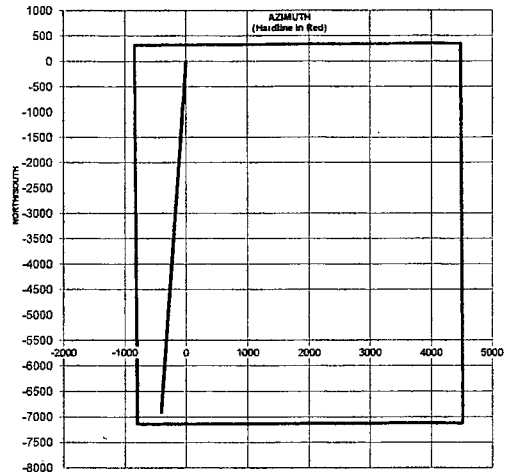

GE Oil & Gas multi-bowl wellhead

System Drawing

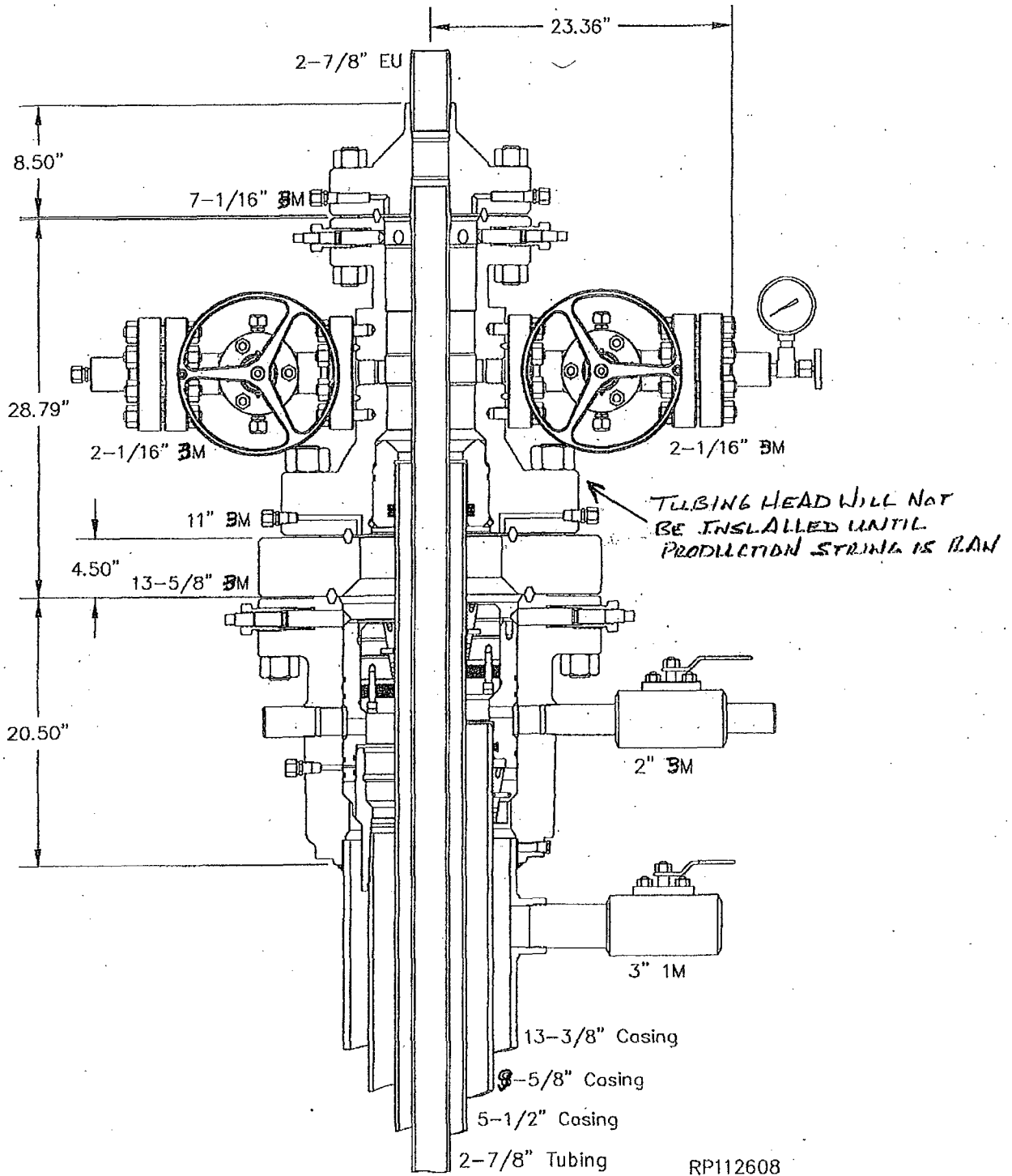

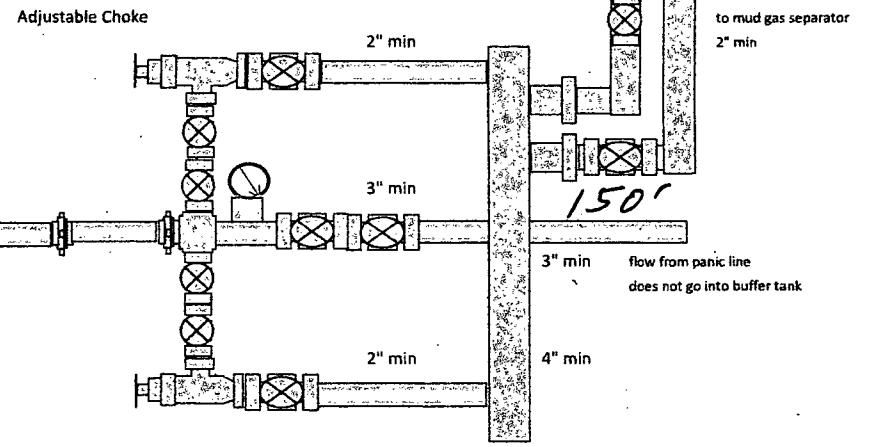
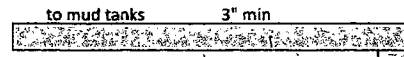
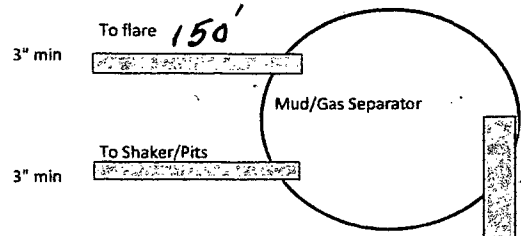
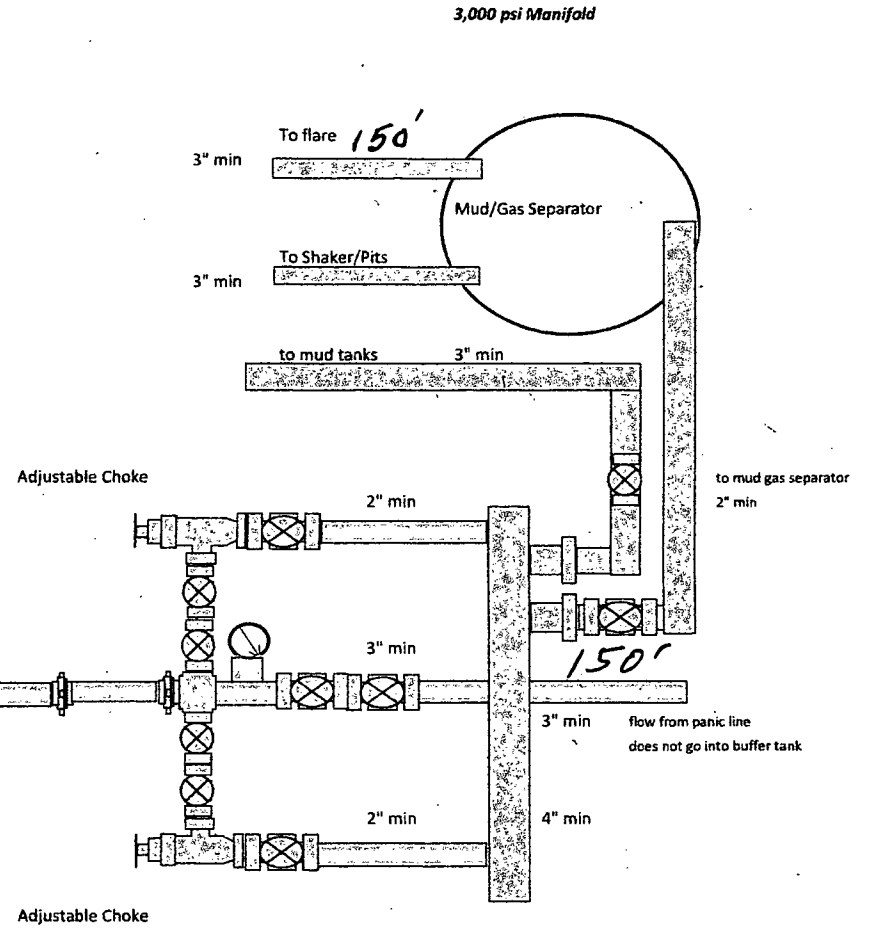
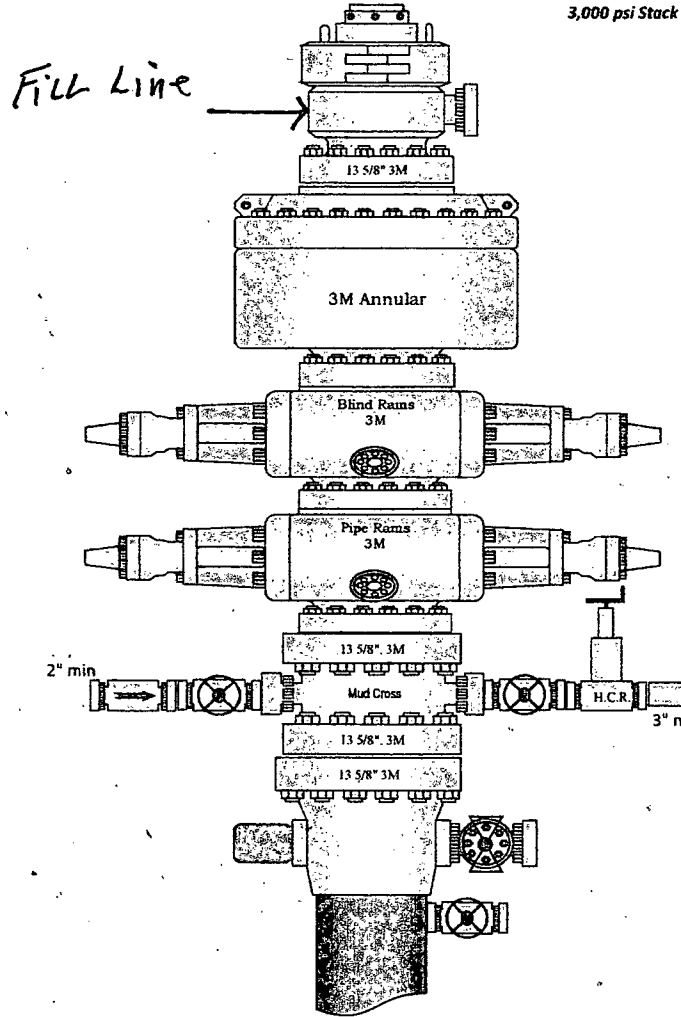

RKI Exploration and Production
3817 N. W. Expressway, Suite 950
Oklahoma City, OK. 73112

Closed Loop System

Design Plan

Equipment List

- 2 – 414 Swaco Centrifuges
- 2 – 4 screen Mongoose shale shakers
- 2 – 250 bbl. tanks to hold fluid
- 2 – CRI Bins with track system
- 2 – 500 bbl. frac tanks for fresh water
- 2 – 500 bbl. frac tanks for brine water

Operation and Maintenance

- Closed Loop equipment will be inspected daily by each tour and any necessary maintenance performed
- Any leak in system will be repaired and/or contained immediately
- OCD notified within 48 hours
- Remediation process started

Closure Plan

During drilling operations, all liquids, drilling fluids and cuttings will be hauled off via CRI (Controlled Recovery Incorporated). Permit #: R-9166.

Plat for Closed Loop System

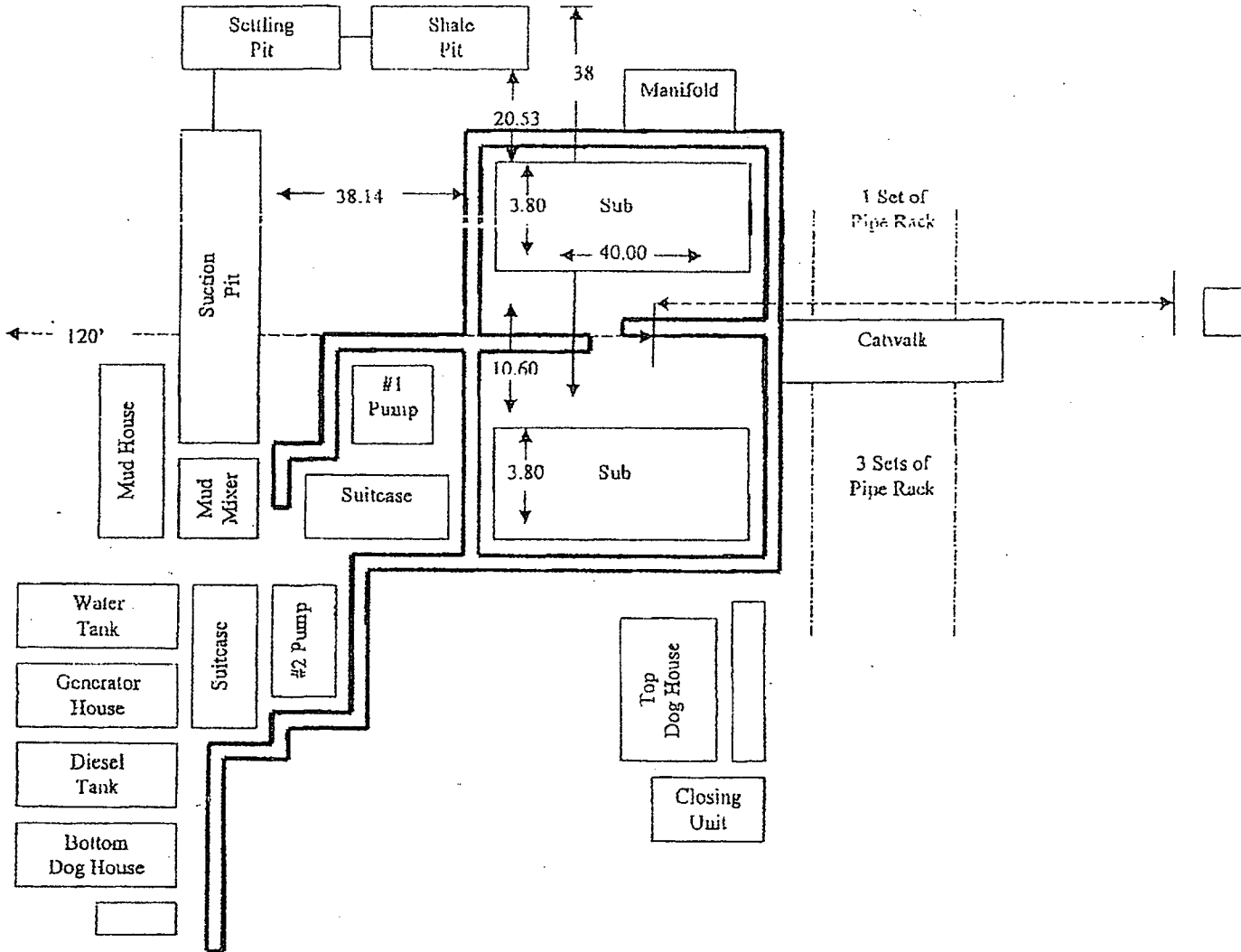

EXHIBIT D

Rig Plat Only
RDX FEDERAL 28-11, RDX FED COM 28-2H & 28-3H
V-DOOR NORTH

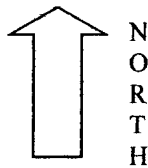
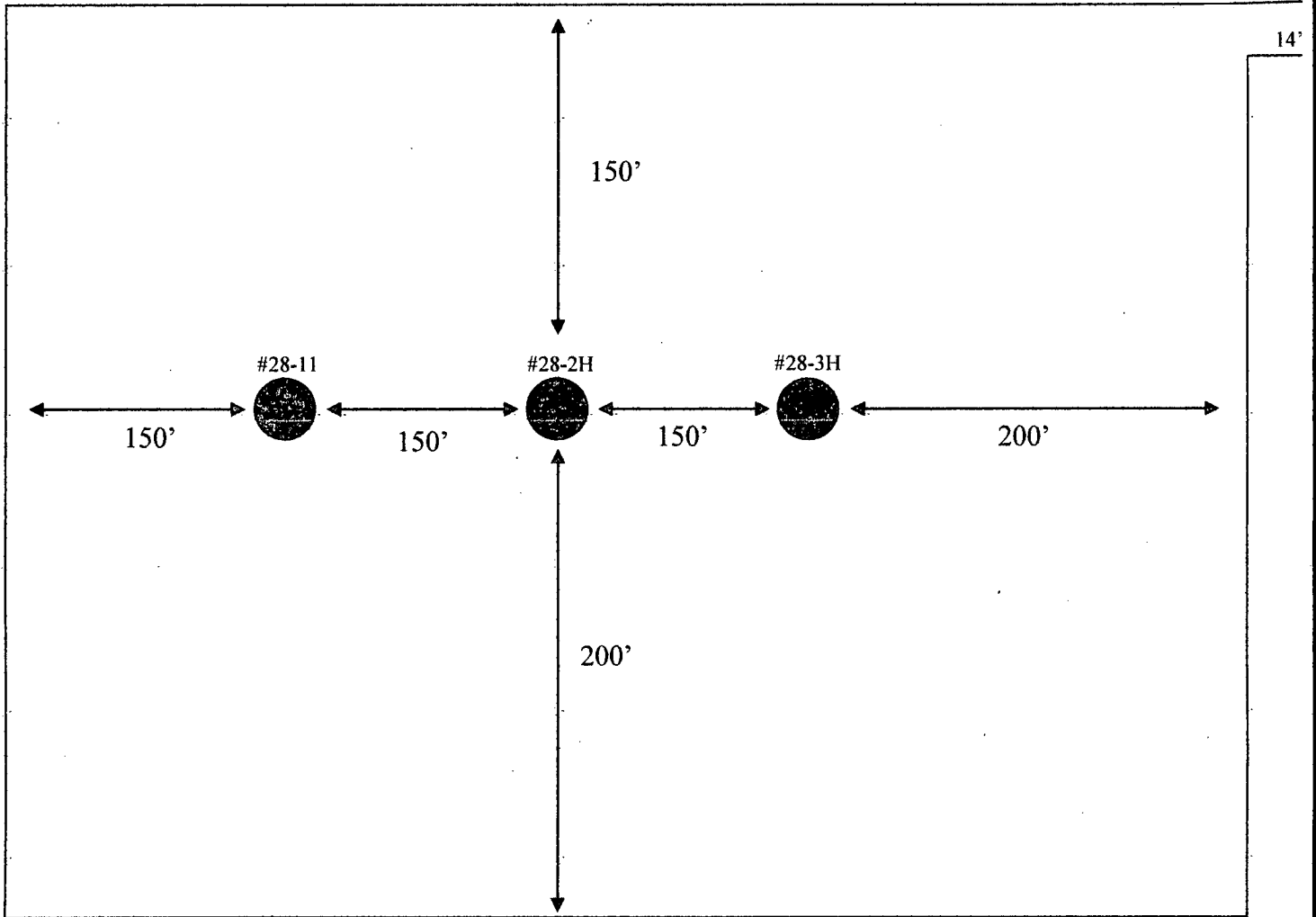
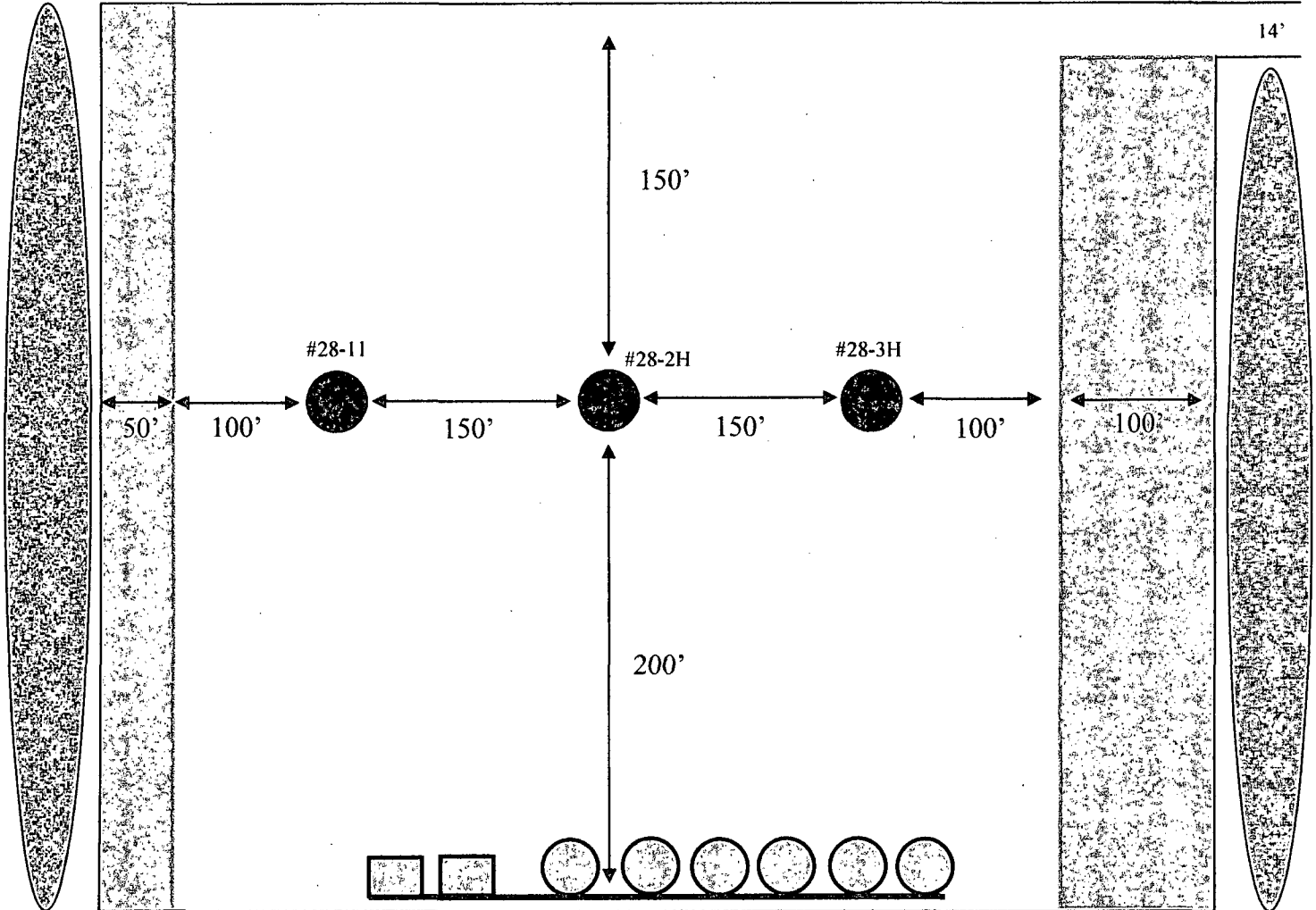







EXHIBIT C

**Interim Reclamation & Production Facilities
RDX FEDERAL 28-11, RDX FED COM 28-2H & 28-3H
V-DOOR NORTH**



LEGEND

-  Well Bore
-  Topsoil
-  Interim Reclamation
-  Production Facilities
-  Production Facilities

 NORTH

SURFACE USE PLAN

RKI Exploration & Production, LLC
RDX FEDERAL COM 28-3H
SHL: 330' FNL & 990' FWL
Section 28, T. 26 S., R. 30 E.
BHL: 230' FSL & 925' FWL
Section 33, T. 26 S., R. 30 E
Eddy County, New Mexico

This plan is submitted with form 3160-3, Application for Permit to Drill, covering the above described well. The purpose of this plan is to describe the location of the proposed well, the proposed construction activities and operations plan, the magnitude of the surface disturbance involved and the procedures to be followed in rehabilitating the surface after completion of the operations, so that a complete appraisal can be made of the environmental effect associated with the operations.

1. EXISTING ROADS:

- A. DIRECTIONS: Go south of Carlsbad, NM, on Highway 285, for 30 miles. Turn east onto the Longhorn road (County Road 725) for 12.6 miles. Turn east on lease road for 2.2 miles. Turn south 1/4 mile, then east for 3/4 mile, then south for 1.50 miles, then 0.50 miles west. The new road begins at this point. All existing roads are either paved or a caliche lease road.
- B. See attached plats and maps provided by WTC Surveys.
- C. The access routes from Eddy County Road 725 to the well location is depicted on **Exhibit A**. The route highlighted in red has been authorized under a ROW permit.
- D. Existing roads on the access route will be improved and maintained to the standard set forth in Section 2 of this Surface Use Plan of Operations.
- E. A right-of-way (ROW) was obtained in September of 2010 to access this well and other leases within the RDX and Ross Draw Unit field.

2. NEW OR RECONSTRUCTED ACCESS ROADS:

- A. The new access road will begin at the northeast corner of the well, east and then north, 450.9 ft., to the RDX Fed 21 #1H..
- B. The maximum width of the driving surface will be 14 feet. The road will be crowned and ditched with a 2% slope from the tip of the crown to the edge of the driving surface. The ditches will be 1 foot deep with 3:1 slopes. The driving surface will be made of 6" rolled and compacted caliche.



Level Ground Section

- C. Surface material will be native caliche. The average grade of the entire road will be approximately 3%.
- D. Fence Cuts: No

- E. Cattle guards: No
- F. Turnouts: No
- G. Culverts: No
- H. Cuts and Fills: Not significant
- I. Approximately 6 inches of topsoil (root zone) will be stripped from the proposed access road prior to any further construction activity. The topsoil that was stripped will be spread along the edge of the road and within the ditch. The topsoil will be seeded with the proper seed mix designated by the BLM.
- J. The access road will be constructed and maintained as necessary to prevent soil erosion and accommodate all-weather traffic. The road will be crowned and ditched with water turnouts installed as necessary to provide for proper drainage along the access road route.
- K. The access road and associated drainage structures will be constructed and maintained in accordance with road guidelines contained in the joint BLM/USFS publication: Surface Operating Standards for Oil and Gas Exploration and Development, The Gold Book, Fourth Edition and/or BLM Manual Section 9113 concerning road construction standards on projects subject to federal jurisdiction.

3. LOCATION OF EXISTING WELLS:

See attached map (**Exhibit B**) showing all wells within a one-mile radius.

4. LOCATION OF EXISTING AND/OR PROPOSED FACILITIES:

- A. In the event the well is found productive, a TANK BATTERY, will be installed on the South portion of the pad (**EXHIBIT C**). A 12.5 kv overhead electric line, of 599.9 ft., consisting of 3 poles, will be installed. The Line will run from the RDX Fed Com #4H & 5H, following the proposed road and existing lateral pipelines, to the well (**SEE EXHIBIT F**). There will also be one 4" poly surface line SWD (90 psi) and one buried, 6" steel, gas pipeline (250 psi), that will tie-in to the existing, buried, gas lateral line and SWD line, just to the north of this well. No new disturbance will be involved (**SEE EXHIBIT E**).
- B. All permanent (on site six months or longer) aboveground structures constructed or installed on location and not subject to safety requirements will be painted to BLM specifications.
- C. Containment berms will be constructed completely around production facilities designed to hold fluids. The containment berms will be constructed or compacted subsoil, be sufficiently impervious, hold 1 ½ times the capacity of the largest tank and away from cut or fill areas.

5. LOCATION AND TYPE OF WATER SUPPLY:

The well will be drilled using a combination of water mud systems as outlined in the Drilling Program. The water will be obtained from commercial water stations in the area and hauled to the location by transport truck using the existing and proposed roads shown in the attached survey plats. If a commercial water well is nearby, a temporary, surface poly line, will be laid along existing roads or other ROW easements and the water pumped to the well. No water well will be drilled on the location.

6. SOURCE OF CONSTRUCTION MATERIALS:

Any construction material that may be required for surfacing of the drill pad and access road will be from a contractor having a permitted source of materials within the general area. All roads will be constructed of 6" rolled and compacted caliche.

7. METHODS OF HANDLING WASTE DISPOSAL:

- A. The well will be drilled utilizing a closed loop mud system. Drill cuttings will be held in roll-off style mud boxes and taken to an NMOCD approved disposal site.
- B. Drilling fluids will be contained in steel mud pits.
- C. Water produced from the well during completion will be held temporarily in steel tanks and then taken to an NMOCD approved commercial disposal facility.
- D. Oil produced during operations will be stored in tanks until sold.
- E. Portable, self-contained chemical toilets will be provided for human waste disposal. Upon completion of operations, or as required, the toilet holding tanks will be pumped and the contents thereof disposed of in an approved sewage disposal facility. All state and local laws and regulations pertaining to disposal of human and solid waste will be complied with. This equipment will be properly maintained during the drilling and completion operations and will be removed when all operations are complete.
- F. All trash, junk, and other waste materials will be contained in trash cages or bins to prevent scattering and will be removed and deposited in an approved sanitary landfill. Immediately after drilling all debris and other waste materials on and around the well location, not contained in the trash cage will be cleaned up and removed from the location. No potentially adverse materials or substances will be left on the location.

8. ANCILLARY FACILITIES:

No campsite, airstrip, or other facilities will be built as a result of the operation of this well. No staging areas are needed.

9. WELL SITE LAYOUT:

- A. **Exhibit D** shows the dimensions of the proposed well pad.
- B. The proposed well pad size will be THREE WELLS ON ONE PAD at 150 ft. apart (RDX Fed 28-11 to the west, the RDX Fed Com 28-2H in the middle and the RDX Fed Com #3H to the east) with a 350' x 650' pad size (**See Exhibit D**). There will be no reserve pit due to the well being drilled utilizing a closed loop mud system. The closed loop system will meet the NMOCD requirements 19.15.17 .
- C. The **Exhibit D**, shows how the wells will be turned to a V-Door North.
- D. A 600' x 600' area has been staked and flagged.
- E. All equipment and vehicles will be confined to the approved disturbed areas of this APD (i.e., access road, well pad, and topsoil storage areas)

10. PLANS FOR SURFACE RECLAMATION:

- A. After concluding the drilling and/or completion operations, if the well is found non-commercial, all the equipment will be removed, the surface material, caliche, will be removed from the well pad and road and transported to the original caliche pit or used for other roads. The original stock piled top soil will be returned to the pad and contoured, as close as possible, to the original topography. The access road will have the caliche removed and the road ripped, barricaded and seeded as directed by the BLM.
- B. If the well is a producer, the portions of the location not essential to production facilities or space required for workover operations, will be reclaimed and seeded as per BLM requirements. (**SEE EXHIBIT C FOR INTERIM RECLAMATION PLAT FOR THIS WELL**)
- C. Reclamation Performance Standards
The following reclamation performance standards will be met:

Interim Reclamation – Includes disturbed areas that may be redisturbed during operations and will be redisturbed at final reclamation to achieve restoration of the original landform and a natural vegetative community.

- Disturbed areas not needed for active, long-term production operations or vehicle travel will be recontoured, protected from erosion, and revegetated with a self-sustaining, vigorous, diverse, native (or as otherwise approved) plant community sufficient to minimize visual impacts, provide forage, stabilize soils, and impede the invasion of noxious, invasive, and non-native weeds.

Final Reclamation – Includes disturbed areas where the original landform and a natural vegetative community will be restored and it is anticipated the site will not be redisturbed for future development.

- The original landform will be restored for all disturbed areas including well pads, production facilities, roads, pipelines, and utility corridors.
- A self-sustaining, vigorous, diverse, native (or otherwise approved) plant community will be established on the site, with a density sufficient to control erosion and invasion by non-native plants and to re-establish wildlife habitat or forage production. At a minimum, the established plant community will consist of species included in the seed mix and/or desirable species occurring in the surrounding natural vegetation.
- Erosion features are equal to or less than surrounding area and erosion control is sufficient so that water naturally infiltrates into the soil and gullying, headcutting, slumping, and deep or excessive rills (greater than 3 inches) are not observed.
- The site will be free of State- or county-listed noxious weeds, oil field debris and equipment, and contaminated soil. Invasive and non-native weeds are controlled.

D. Reclamation Actions

Earthwork for interim and final reclamation will be completed within 6 months of well completion or plugging unless a delay is approved in writing by the BLM authorized officer.

The following minimum reclamation actions will be taken to ensure that the reclamation objectives and standards are met. It may be necessary to take additional reclamation actions beyond the minimum in order to achieve the Reclamation Standards.

Reclamation – General

Notification:

- The BLM will be notified at least 3 days prior to commencement of any reclamation operations.

Housekeeping:

- Within 30 days of well completion, the well location and surrounding areas(s) will be cleared of, and maintained free of, all debris, materials, trash, and equipment not required for production.
- No hazardous substances, trash, or litter will be buried or placed in pits.

13. BOND COVERAGE:

Bond Coverage is Nationwide; Bond Number NMB-000460.

OPERATORS REPRESENTATIVE:

The RKI Exploration and Production, LLC representatives responsible for ensuring compliance of the surface use plan are listed below:

Surface:

Barry W. Hunt – Permitting Agent
1403 Springs Farm Place
Carlsbad, NM 88220
(575) 885-1417 (Home)
(575) 361-4078 (Cell)

Drilling & Production:

Ken Fairchild – RKI Exploration and Production, LLC.
210 Park Avenue, Suite 900
Oklahoma City, Ok. 73102
(405) 996-5764 (Office)
(469) 693-6051 (Cell)

ON-SITE PERFORMED ON 2/06/13 RESULTED IN PROPOSED LOCATION BEING MOVED 255 FT. EAST, SO AS TO ALLOW FOR 200 METERS FROM 100 YEAR FLOODPLAIN TO THE WEST. IT WAS AGREED TO TURN THE LOCATION TO A V-DOOR NORTH, PLACE THE TOP SOIL TO THE EAST, PLACE THE BATTERY TO THE SOUTH AND RUN ACCESS FROM NORTHEAST CORNER OF PAD, EAST TO INTERSECT ROAD TO THE RDX FED COM 28-4H & 5H AND THE RDX FED 21-1H. IT WAS FURTHER AGREED TO RECLAIM THE ~~NORTH~~ AND EAST PORTIONS OF THE PAD.

WEST

PRESENT AT ON-SITE:

**BARRY HUNT – PERMITTING AGENT FOR RKI EXPLORATION & PRODUCTION
AMANDA LYNCH – BLM
BECKIE HILL - BOONE ARCHAEOLOGICAL SERVICES
WTC SURVEYORS**

SURFACE USE PLAN
RKI Exploration & Production, LLC
RDX FEDERAL COM 28-8H
SHL: 350' FNL & 1077' FEL
Section 28, T. 26 S., R. 30 E.
BHL: 230' FSL & 395' FEL
Section 33, T. 26 S., R. 30 E
Eddy County, New Mexico

This plan is submitted with form 3160-3, Application for Permit to Drill, covering the above described well. The purpose of this plan is to describe the location of the proposed well, the proposed construction activities and operations plan, the magnitude of the surface disturbance involved and the procedures to be followed in rehabilitating the surface after completion of the operations, so that a complete appraisal can be made of the environmental effect associated with the operations.

1. EXISTING ROADS:

- A. DIRECTIONS: Go south of Carlsbad, NM, on Highway 285, for 30 miles. Turn east onto the Longhorn road (County Road 725) for 12.6 miles. Turn east on lease road for 2.2 miles. Turn south 1/4 mile, then east for 3/4 mile, then south for 1.50 miles. The new well pad will be west of the road. All existing roads are either paved or a caliche lease road.
- B. See attached plats and maps provided by WTC Surveys.
- C. The access routes from Eddy County Road 725 to the well location is depicted on **Exhibit A**. The route highlighted in red has been authorized under a ROW permit.
- D. Existing roads on the access route will be improved and maintained to the standard set forth in Section 2 of this Surface Use Plan of Operations.
- E. A right-of-way (ROW) was obtained in September of 2010 to access this well and other leases within the RDX and Ross Draw Unit field.

2. NEW OR RECONSTRUCTED ACCESS ROADS:

- A. The new access road will begin at the northwest corner of the well, west, to the access road for the RDX Federal 28-6H & 7H. The new road length will be 317 ft.
- B. The maximum width of the driving surface will be 14 feet. The road will be crowned and ditched with a 2% slope from the tip of the crown to the edge of the driving surface. The ditches will be 1 foot deep with 3:1 slopes. The driving surface will be made of 6" rolled and compacted caliche.

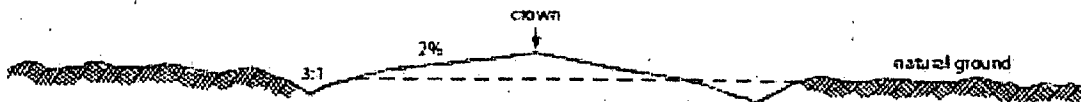

Level Ground Section

- C. Surface material will be native caliche. The average grade of the entire road will be approximately 3%.
- D. Fence Cuts: No
- E. Cattle guards: No

- E. Cattle guards: No
- F. Turnouts: No
- G. Culverts: No
- H. Cuts and Fills: Not significant
- I. Approximately 6 inches of topsoil (root zone) will be stripped from the proposed access road prior to any further construction activity. The topsoil that was stripped will be spread along the edge of the road and within the ditch. The topsoil will be seeded with the proper seed mix designated by the BLM.
- J. The access road will be constructed and maintained as necessary to prevent soil erosion and accommodate all-weather traffic. The road will be crowned and ditched with water turnouts installed as necessary to provide for proper drainage along the access road route.
- K. The access road and associated drainage structures will be constructed and maintained in accordance with road guidelines contained in the joint BLM/USFS publication: Surface Operating Standards for Oil and Gas Exploration and Development, The Gold Book, Fourth Edition and/or BLM Manual Section 9113 concerning road construction standards on projects subject to federal jurisdiction.

3. LOCATION OF EXISTING WELLS:

See attached map (**Exhibit B**) showing all wells within a one-mile radius.

4. LOCATION OF EXISTING AND/OR PROPOSED FACILITIES:

- A. In the event the well is found productive, a TANK BATTERY, will be installed on the South portion of the pad (**EXHIBIT C**). A 12.5 kv overhead electric line, of 559.9 ft., consisting of 3 poles, will be installed. The Line will run from the RDX Fed Com #4H & 5H, following the proposed road and existing lateral pipelines, to the well (**SEE EXHIBIT F**). There will also be one 4" poly surface line SWD (90 psi) and one buried, 6" steel, gas pipeline (250 psi), that will tie-in to the existing, buried, gas lateral line and SWD line, just to the north of this well. No new disturbance will be involved (**SEE EXHIBIT E**).
- B. All permanent (on site six months or longer) aboveground structures constructed or installed on location and not subject to safety requirements will be painted to BLM specifications.
- C. Containment berms will be constructed completely around production facilities designed to hold fluids. The containment berms will be constructed or compacted subsoil, be sufficiently impervious, hold 1 ½ times the capacity of the largest tank and away from cut or fill areas.

5. LOCATION AND TYPE OF WATER SUPPLY:

The well will be drilled using a combination of water mud systems as outlined in the Drilling Program. The water will be obtained from commercial water stations in the area and hauled to the location by transport truck using the existing and proposed roads shown in the attached survey plats. If a commercial water well is nearby, a temporary, surface poly line, will be laid along existing roads or other ROW easements and the water pumped to the well. No water well will be drilled on the location.

6. SOURCE OF CONSTRUCTION MATERIALS:

Any construction material that may be required for surfacing of the drill pad and access road will be from a contractor having a permitted source of materials within the general area. All roads will be constructed of 6" rolled and compacted caliche.

7. METHODS OF HANDLING WASTE DISPOSAL:

- A. The well will be drilled utilizing a closed loop mud system. Drill cuttings will be held in roll-off style mud boxes and taken to an NMOCD approved disposal site.
- B. Drilling fluids will be contained in steel mud pits.
- C. Water produced from the well during completion will be held temporarily in steel tanks and then taken to an NMOCD approved commercial disposal facility.
- D. Oil produced during operations will be stored in tanks until sold.
- E. Portable, self-contained chemical toilets will be provided for human waste disposal. Upon completion of operations, or as required, the toilet holding tanks will be pumped and the contents thereof disposed of in an approved sewage disposal facility. All state and local laws and regulations pertaining to disposal of human and solid waste will be complied with. This equipment will be properly maintained during the drilling and completion operations and will be removed when all operations are complete.
- F. All trash, junk, and other waste materials will be contained in trash cages or bins to prevent scattering and will be removed and deposited in an approved sanitary landfill. Immediately after drilling all debris and other waste materials on and around the well location, not contained in the trash cage will be cleaned up and removed from the location. No potentially adverse materials or substances will be left on the location.

8. ANCILLARY FACILITIES:

No campsite, airstrip, or other facilities will be built as a result of the operation of this well. No staging areas are needed.

9. WELL SITE LAYOUT:

- A. **Exhibit D** shows the dimensions of the proposed well pad.
- B. The proposed well pad size will be THREE WELLS ON ONE PAD at 150 ft. apart (RDX Fed 28-11 to the west, the RDX Fed Com 28-2H in the middle and the RDX Fed Com #3H to the east) with a 350' x 650' pad size (**See Exhibit D**). There will be no reserve pit due to the well being drilled utilizing a closed loop mud system. The closed loop system will meet the NMOCD requirements 19.15.17.
- C. The **Exhibit D**, shows how the wells will be turned to a V-Door North.
- D. A 600' x 600' area has been staked and flagged.
- E. All equipment and vehicles will be confined to the approved disturbed areas of this APD (i.e., access road, well pad, and topsoil storage areas)

10. PLANS FOR SURFACE RECLAMATION:

- A. After concluding the drilling and/or completion operations, if the well is found non-commercial, all the equipment will be removed, the surface material, caliche, will be removed from the well pad and road and transported to the original caliche pit or used for other roads. The original stock piled top soil will be returned to the pad and contoured, as close as possible, to the original topography. The access road will have the caliche removed and the road ripped, barricaded and seeded as directed by the BLM.
- B. If the well is a producer, the portions of the location not essential to production facilities or space required for workover operations, will be reclaimed and seeded as per BLM requirements. (**SEE EXHIBIT C FOR INTERIM RECLAMATION PLAT FOR THIS WELL**)
- C. Reclamation Performance Standards
The following reclamation performance standards will be met:

Interim Reclamation – Includes disturbed areas that may be redisturbed during operations and will be redisturbed at final reclamation to achieve restoration of the original landform and a natural vegetative community.

- Disturbed areas not needed for active, long-term production operations or vehicle travel will be recontoured, protected from erosion, and revegetated with a self-sustaining, vigorous, diverse, native (or as otherwise approved) plant community sufficient to minimize visual impacts, provide forage, stabilize soils, and impede the invasion of noxious, invasive, and non-native weeds.

Final Reclamation – Includes disturbed areas where the original landform and a natural vegetative community will be restored and it is anticipated the site will not be redisturbed for future development.

- The original landform will be restored for all disturbed areas including well pads, production facilities, roads, pipelines, and utility corridors.
- A self-sustaining, vigorous, diverse, native (or otherwise approved) plant community will be established on the site, with a density sufficient to control erosion and invasion by non-native plants and to re-establish wildlife habitat or forage production. At a minimum, the established plant community will consist of species included in the seed mix and/or desirable species occurring in the surrounding natural vegetation.
- Erosion features are equal to or less than surrounding area and erosion control is sufficient so that water naturally infiltrates into the soil and gullyng, headcutting, slumping, and deep or excessive rills (greater than 3 inches) are not observed.
- The site will be free of State- or county-listed noxious weeds, oil field debris and equipment, and contaminated soil. Invasive and non-native weeds are controlled.

D. Reclamation Actions

Earthwork for interim and final reclamation will be completed within 6 months of well completion or plugging unless a delay is approved in writing by the BLM authorized officer.

The following minimum reclamation actions will be taken to ensure that the reclamation objectives and standards are met. It may be necessary to take additional reclamation actions beyond the minimum in order to achieve the Reclamation Standards.

Reclamation – General

Notification:

- The BLM will be notified at least 3 days prior to commencement of any reclamation operations.

Housekeeping:

- Within 30 days of well completion, the well location and surrounding areas(s) will be cleared of, and maintained free of, all debris, materials, trash, and equipment not required for production.
- No hazardous substances, trash, or litter will be buried or placed in pits.

Topsoil Management:

- Operations will disturb the minimum amount of surface area necessary to conduct safe and efficient operations.
- Topsoil depth is defined as the top layer of soil that contains 80% of the roots. In areas to be heavily disturbed, the topsoil will be stripped and stockpiled around the perimeter of the well location and along the perimeter of the access road to control run-on and run-off, to keep topsoil viable, and to make redistribution of topsoil more efficient during interim reclamation. Stockpiled topsoil will include vegetative material. Topsoil will be clearly segregated and stored separately from subsoils.
- Salvaging and spreading topsoil will not be performed when the ground or topsoil is frozen or too wet to adequately support construction equipment or so dry that dust clouds greater than 30 feet tall are created. If such equipment creates ruts in excess of four (4) inches deep, the soil will be deemed too wet.
- No major depressions will be left that would trap water and cause ponding unless the intended purpose is to trap runoff and sediment.

Seeding:

- Seedbed Preparation. Initial seedbed preparation will consist of recontouring to the appropriate interim or final reclamation standard. All compacted areas to be seeded will be ripped to a minimum depth of 18 inches with a minimum furrow spacing of 2 feet, followed by recontouring the surface and then evenly spreading the stockpiled topsoil. Prior to seeding, the seedbed will be scarified to a depth of no less than 4 – 6 inches. If the site is to be broadcast seeded, the surface will be left rough enough to trap seed and snow, control erosion, and increase water infiltration.
- If broadcast seeding is to be used and is delayed, final seedbed preparation will consist of contour cultivating to a depth of 4 to 6 inches within 24 hours prior to seeding, dozer tracking, or other imprinting in order to break the soil crust and create seed germination micro-sites.
- Seed Application. Seeding will be conducted no more than two weeks following completion of final seedbed preparation. A certified weed-free seed mix designed by the BLM to meet reclamation standards will be used.
- If the site is harrowed or dragged, seed will be covered by no more than 0.25 inch of soil.

11. SURFACE OWNERSHIP:

- A. The surface is owned by the U. S. Government and is administered by the Bureau of Land Management. The surface is multiple use with the primary uses of the region for the grazing of livestock and the production of oil and gas.

12. OTHER INFORMATION:

- A. The area surrounding the well site is in a gentle sloped, shallow sandy loam, rolling hills type area. The vegetation consists of Mesquite, Creosote, White-Thorn Acacia with three-awns and some dropseed species.
- B. There is no permanent or live water in the immediate area.
- C. There are no dwellings within 2 miles of this location.
- D. RKI is a participant with the Permian Basin MOA and a check for \$1507 is attached with this application.

13. BOND COVERAGE:

Bond Coverage is Nationwide; Bond Number NMB-000460.

OPERATORS REPRESENTATIVE:

The RKI Exploration and Production, LLC representatives responsible for ensuring compliance of the surface use plan are listed below:

Surface:

Barry W. Hunt – Permitting Agent
1403 Springs Farm Place
Carlsbad, NM 88220
(575) 885-1417 (Home)
(575) 361-4078 (Cell)

Drilling & Production:

Ken Fairchild – RKI Exploration and Production, LLC.
210 Park Avenue, Suite 900
Oklahoma City, Ok. 73102
(405) 996-5764 (Office)
(469) 693-6051 (Cell)

ON-SITE PERFORMED ON 2/06/13 RESULTED IN PROPOSED LOCATION BEING MOVED 255 FT. EAST, SO AS TO ALLOW FOR 200 METERS FROM 100 YEAR FLOODPLAIN TO THE WEST. IT WAS AGREED TO TURN THE LOCATION TO A V-DOOR NORTH, PLACE THE TOP SOIL TO THE WEST, PLACE THE BATTERY TO THE SOUTH AND RUN ACCESS FROM NORTHEAST CORNER OF PAD, EAST TO INTERSECT ROAD TO THE RDX FED COM 28-4H & 5H AND THE RDX FED 21-1H. IT WAS FURTHER AGREED TO RECLAIM THE EAST AND WEST PORTION OF THE PAD.

PRESENT AT ON-SITE:

**BARRY HUNT – PERMITTING AGENT FOR RKI EXPLORATION & PRODUCTION
AMANDA LYNCH – BLM
BECKIE HILL - BOONE ARCHAEOLOGICAL SERVICES
WTC SURVEYORS**

RKI Exploration & Production LLC

3817 NW Expressway, Suite 950, Oklahoma City, OK 73112
405-949-2221 Fax 405-949-2223

June 25th, 2012

To Whom It May Concern:

Please be advised that Mr. Barry Hunt has been retained by RKI Exploration & Production to sign as our agent on Application for Permit to Drill (APD) as well as Right of Way applications within the States of New Mexico and Texas.

If you have any questions or require additional information, please feel free to contact me at (405) 996-5771.

Sincerely,

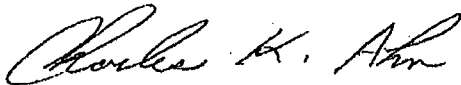

Charles K. Ahn
EH&S/Regulatory Manager

PECOS DISTRICT CONDITIONS OF APPROVAL

OPERATOR'S NAME:	RKI Exploration & Production, LLC
LEASE NO.:	NMNM-35607
WELL NAME & NO.:	RDX Federal Com 28-2H
SURFACE HOLE FOOTAGE:	0330' FNL & 0840' FWL
BOTTOM HOLE FOOTAGE:	0230' FSL & 0395' FWL Sec. 33, T. 26 S., R 30 E.
LOCATION:	Section 28, T. 26 S., R 30 E., NMPM
COUNTY:	Eddy County, New Mexico

TABLE OF CONTENTS

Standard Conditions of Approval (COA) apply to this APD. If any deviations to these standards exist or special COAs are required, the section with the deviation or requirement will be checked below.

- General Provisions**
- Permit Expiration**
- Archaeology, Paleontology, and Historical Sites**
- Noxious Weeds**
- Special Requirements**
 - Phantom Banks Special Management Area
 - Watershed
 - Communitization Agreement
- Construction**
 - Notification
 - Topsoil
 - Closed Loop System
 - Federal Mineral Material Pits
 - Well Pads
 - Roads
- Road Section Diagram**
- Drilling**
 - Cement Requirements
 - Medium Cave/Karst
 - Logging Requirements
 - Waste Material and Fluids
- Production (Post Drilling)**
 - Well Structures & Facilities
 - Pipelines
 - Electric Lines
- Interim Reclamation**
- Final Abandonment & Reclamation**

I. GENERAL PROVISIONS

The approval of the Application For Permit To Drill (APD) is in compliance with all applicable laws and regulations: 43 Code of Federal Regulations 3160, the lease terms, Onshore Oil and Gas Orders, Notices To Lessees, New Mexico Oil Conservation Division (NMOCD) Rules, National Historical Preservation Act As Amended, and instructions and orders of the Authorized Officer. Any request for a variance shall be submitted to the Authorized Officer on Form 3160-5, Sundry Notices and Report on Wells.

II. PERMIT EXPIRATION

If the permit terminates prior to drilling and drilling cannot be commenced within 60 days after expiration, an operator is required to submit Form 3160-5, Sundry Notices and Reports on Wells, requesting surface reclamation requirements for any surface disturbance. However, if the operator will be able to initiate drilling within 60 days after the expiration of the permit, the operator must have set the conductor pipe in order to allow for an extension of 60 days beyond the expiration date of the APD. (Filing of a Sundry Notice is required for this 60 day extension.)

III. ARCHAEOLOGICAL, PALEONTOLOGY & HISTORICAL SITES

Any cultural and/or paleontological resource discovered by the operator or by any person working on the operator's behalf shall immediately report such findings to the Authorized Officer. The operator is fully accountable for the actions of their contractors and subcontractors. The operator shall suspend all operations in the immediate area of such discovery until written authorization to proceed is issued by the Authorized Officer. An evaluation of the discovery shall be made by the Authorized Officer to determine the appropriate actions that shall be required to prevent the loss of significant cultural or scientific values of the discovery. The operator shall be held responsible for the cost of the proper mitigation measures that the Authorized Officer assesses after consultation with the operator on the evaluation and decisions of the discovery. Any unauthorized collection or disturbance of cultural or paleontological resources may result in a shutdown order by the Authorized Officer.

IV. NOXIOUS WEEDS

The operator shall be held responsible if noxious weeds become established within the areas of operations. Weed control shall be required on the disturbed land where noxious weeds exist, which includes the roads, pads, associated pipeline corridor, and adjacent land affected by the establishment of weeds due to this action. The operator shall consult with the Authorized Officer for acceptable weed control methods, which include following EPA and BLM requirements and policies.

V. SPECIAL REQUIREMENT(S)

Phantom Bank Heronry

Surface disturbance will not be allowed within up to 200 meters of active heronries or by delaying activity for up to 120 days, or a combination of both. Exhaust noise from pump jack engines must be muffled or otherwise controlled so as not to exceed 75 db measured at 30 ft. from the source of the noise

Condition of Approval for protecting watershed:

- Surface disturbance will not be allowed outside of approved pad.
- The entire well pad will be bermed to prevent oil, salt, and other chemical contaminants from leaving the well pad. Topsoil shall not be used to construct the berm. No water flow from the uphill side(s) of the pad shall be allowed to enter the well pad. The berm shall be maintained through the life of the well and after interim reclamation has been completed.
- Any water erosion that may occur due to the construction of the well pad during the life of the well will be quickly corrected and proper measures will be taken to prevent future erosion.
- Stockpiling of topsoil is required. The top soil shall be stockpiled in an appropriate location to prevent loss of soil due to water or wind erosion and not used for berming or erosion control.

Tank Battery COAs Only:

- Tank battery locations will be lined and bermed. A 20 mil permanent liner will be installed with a 4 oz. felt backing to prevent tears or punctures. Tank battery berms must be large enough to contain 1 ½ times the content of the largest tank.
- Automatic shut off, check valves, or similar systems will be installed for tanks to minimize the effects of catastrophic line failures used in production or drilling.

Drilling:

Communitization Agreement

A Communitization Agreement covering the acreage dedicated to this well must be filed for approval with the BLM. The effective date of the agreement shall be prior to any sales. In addition, the well sign shall include the surface and bottom hole lease numbers. If the Communitization Agreement number is known, it shall also be on the sign. If not, it shall be placed on the sign when the sign is replaced.

VI. CONSTRUCTION

A. NOTIFICATION

The BLM shall administer compliance and monitor construction of the access road and well pad. Notify the Carlsbad Field Office at (575) 234-5909 at least 3 working days prior to commencing construction of the access road and/or well pad.

When construction operations are being conducted on this well, the operator shall have the approved APD and Conditions of Approval (COA) on the well site and they shall be made available upon request by the Authorized Officer.

B. TOPSOIL

The operator shall strip the top portion of the soil (root zone) from the entire well pad area and stockpile the topsoil along the edge of the well pad as depicted in the APD. The root zone is typically six (6) inches in depth. All the stockpiled topsoil will be redistributed over the interim reclamation areas. Topsoil shall not be used for berming the pad or facilities. For final reclamation, the topsoil shall be spread over the entire pad area for seeding preparation.

Other subsoil (below six inches) stockpiles must be completely segregated from the topsoil stockpile. Large rocks or subsoil clods (not evident in the surrounding terrain) must be buried within the approved area for interim and final reclamation.

C. CLOSED LOOP SYSTEM

Tanks are required for drilling operations: No Pits.

The operator shall properly dispose of drilling contents at an authorized disposal site.

D. FEDERAL MINERAL MATERIALS PIT

Payment shall be made to the BLM prior to removal of any federal mineral materials. Call the Carlsbad Field Office at (575) 234-5972.

E. WELL PAD SURFACING

Surfacing of the well pad is not required.

If the operator elects to surface the well pad, the surfacing material may be required to be removed at the time of reclamation. The well pad shall be constructed in a manner which creates the smallest possible surface disturbance, consistent with safety and operational needs.

F. EXCLOSURE FENCING (CELLARS & PITS)

Exclosure Fencing

The operator will install and maintain exclosure fencing for all open well cellars to prevent access to public, livestock, and large forms of wildlife before and after drilling operations until the pit is free of fluids and the operator initiates backfilling. (For examples of exclosure fencing design, refer to BLM's Oil and Gas Gold Book, Exclosure Fence Illustrations, Figure 1, Page 18.)

G. ON LEASE ACCESS ROADS**Road Width**

The access road shall have a driving surface that creates the smallest possible surface disturbance and does not exceed fourteen (14) feet in width. The maximum width of surface disturbance, when constructing the access road, shall not exceed twenty-five (25) feet.

Surfacing

Surfacing material is not required on the new access road driving surface. If the operator elects to surface the new access road or pad, the surfacing material may be required to be removed at the time of reclamation.

Where possible, no improvements should be made on the unsurfaced access road other than to remove vegetation as necessary, road irregularities, safety issues, or to fill low areas that may sustain standing water.

The Authorized Officer reserves the right to require surfacing of any portion of the access road at any time deemed necessary. Surfacing may be required in the event the road deteriorates, erodes, road traffic increases, or it is determined to be beneficial for future field development. The surfacing depth and type of material will be determined at the time of notification.

Crowning

Crowning shall be done on the access road driving surface. The road crown shall have a grade of approximately 2% (i.e., a 1" crown on a 14' wide road). The road shall conform to Figure 1; cross section and plans for typical road construction.

Ditching

Ditching shall be required on both sides of the road.

Turnouts

Vehicle turnouts shall be constructed on the road. Turnouts shall be intervisible with interval spacing distance less than 1000 feet. Turnouts shall conform to Figure 1; cross section and plans for typical road construction.

Drainage

Drainage control systems shall be constructed on the entire length of road (e.g. ditches, sidehill out-sloping and in-sloping, lead-off ditches, culvert installation, and low water crossings).

A typical lead-off ditch has a minimum depth of 1 foot below and a berm of 6 inches above natural ground level. The berm shall be on the down-slope side of the lead-off ditch.

Cross Section of a Typical Lead-off Ditch

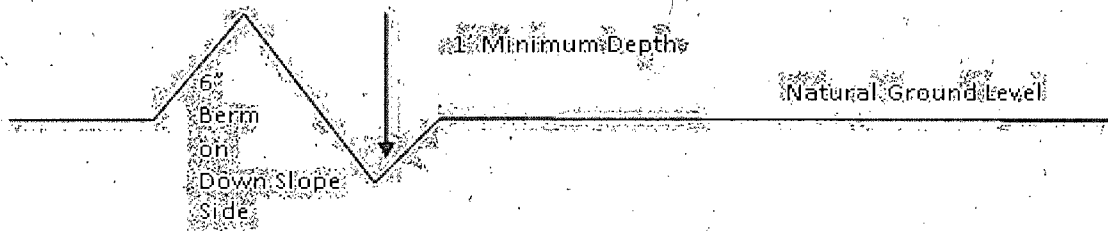

All lead-off ditches shall be graded to drain water with a 1 percent minimum to 3 percent maximum ditch slope. The spacing interval are variable for lead-off ditches and shall be determined according to the formula for spacing intervals of lead-off ditches, but may be amended depending upon existing soil types and centerline road slope (in %);

Formula for Spacing Interval of Lead-off Ditches

Example - On a 4% road slope that is 400 feet long, the water flow shall drain water into a lead-off ditch. Spacing interval shall be determined by the following formula:

$$400 \text{ foot road with } 4\% \text{ road slope: } \frac{400'}{4\%} + 100' = 200' \text{ lead-off ditch interval}$$

Cattleguards

An appropriately sized cattleguard sufficient to carry out the project shall be installed and maintained at fence/road crossings. Any existing cattleguards on the access road route shall be repaired or replaced if they are damaged or have deteriorated beyond practical use. The operator shall be responsible for the condition of the existing cattleguards that are in place and are utilized during lease operations.

Fence Requirement

Where entry is granted across a fence line, the fence shall be braced and tied off on both sides of the passageway prior to cutting. The operator shall notify the private surface landowner or the grazing allotment holder prior to crossing any fences.

Public Access

Public access on this road shall not be restricted by the operator without specific written approval granted by the Authorized Officer.

Construction Steps

1. Salvage topsoil
2. Construct road

3. Redistribute topsoil
4. Revegetate slopes

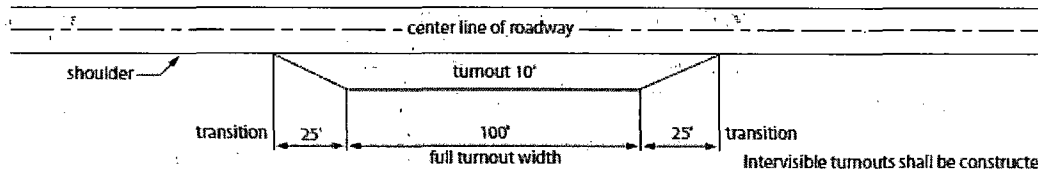

Intervisible turnouts shall be constructed on all single lane roads on all blind curves with additional turnouts as needed to keep spacing below 1000 feet.

Typical Turnout Plan

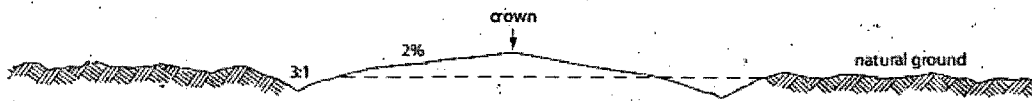

Level Ground Section

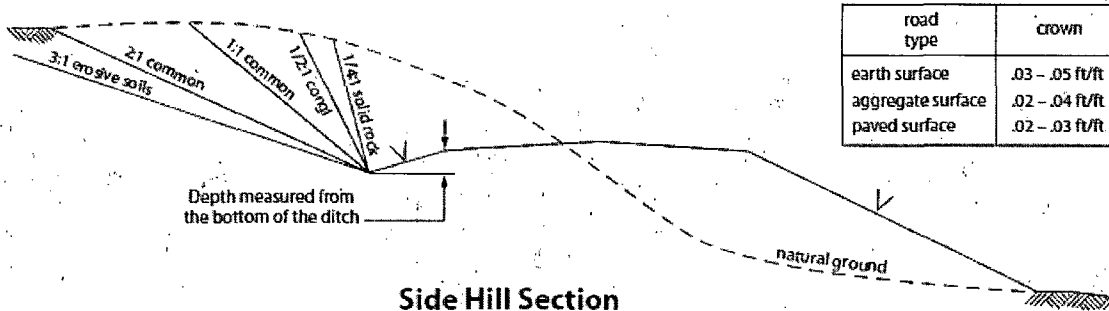

Side Hill Section

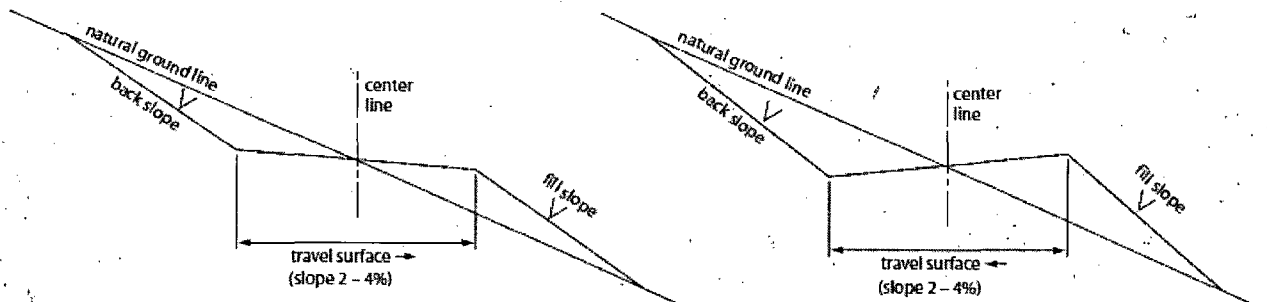

Typical Outsloped Section

Typical Insloped Section

Figure 1. Cross-sections and plans for typical road sections representative of BLM resource or FS local and higher-class roads.

VII. DRILLING

A. DRILLING OPERATIONS REQUIREMENTS

The BLM is to be notified in advance for a representative to witness:

- a. Spudding well (minimum of 24 hours)
- b. Setting and/or Cementing of all casing strings (minimum of 4 hours)
- c. BOPE tests (minimum of 4 hours)

Eddy County

Call the Carlsbad Field Office, 620 East Greene St., Carlsbad, NM 88220,
(575) 361-2822

1. **Although Hydrogen Sulfide has not been reported in the area, it is always a potential hazard. If Hydrogen Sulfide is encountered, report measured amounts and formations to the BLM.**
2. Unless the production casing has been run and cemented or the well has been properly plugged, the drilling rig shall not be removed from over the hole without prior approval. **If the drilling rig is removed without approval – an Incident of Non-Compliance will be written and will be a “Major” violation.**
3. Floor controls are required for 3M or Greater systems. These controls will be on the rig floor, unobstructed, readily accessible to the driller and will be operational at all times during drilling and/or completion activities. Rig floor is defined as the area immediately around the rotary table; the area immediately above the substructure on which the draw works is located, this does not include the dog house or stairway area.
4. **The record of the drilling rate along with the GR/N well log run from TD to surface shall be submitted to the BLM office as well as all other logs run on the borehole 30 days from completion. If available, a digital copy of the logs is to be submitted in addition to the paper copies. The Rustler top and top and bottom of Salt are to be recorded on the Completion Report.**

B. CASING

Changes to the approved APD casing program need prior approval if the items substituted are of lesser grade or different casing size. The Operator can exchange the components of the proposal with that of superior strength (i.e. changing from J-55 to N-80, or from 36# to 40#). Changes to the approved cement program need prior approval if the altered cement plan has less volume or strength or if the changes are substantial (i.e. Multistage tool, ECP, etc.).

Centralizers required on surface casing per Onshore Order 2.III.B.1.f.

Wait on cement (WOC) time prior to drilling out for a primary cement job will be a minimum 18 hours for a water basin, 24 hours in the potash area, or 500 pounds compressive strength, whichever is greater for all casing strings. DURING THIS WOC TIME, NO DRILL PIPE, ETC. SHALL BE RUN IN THE HOLE. Provide compressive strengths including hours to reach required 500 pounds compressive strength prior to cementing each casing string. IF OPERATOR DOES NOT HAVE THE WELL SPECIFIC CEMENT DETAILS ONSITE PRIOR TO PUMPING THE CEMENT FOR EACH CASING STRING, THE WOC WILL BE 30 HOURS. See individual casing strings for details regarding lead cement slurry requirements.

No pea gravel permitted for remedial or fall back remedial without prior authorization from the BLM engineer.

Medium Cave/Karst

Possibility of water flows in the Salado and Castile.

Possibility of lost circulation in the Delaware.

1. The **13-3/8** inch surface casing shall be set at approximately **725** feet (**in a competent bed below the Magenta Dolomite, which is a Member of the Rustler, and if salt is encountered, set casing at least 25 feet above the salt**) and cemented to the surface.
 - a. If cement does not circulate to the surface, the appropriate BLM office shall be notified and a temperature survey utilizing an electronic type temperature survey with surface log readout will be used or a cement bond log shall be run to verify the top of the cement. Temperature survey will be run a minimum of six hours after pumping cement and ideally between 8-10 hours after completing the cement job.
 - b. **Wait on cement (WOC) time for a primary cement job is to include the lead cement slurry.**
 - c. Wait on cement (WOC) time for a remedial job will be a minimum of 4 hours after bringing cement to surface or 500 pounds compressive strength, whichever is greater.
 - d. If cement falls back, remedial cementing will be done prior to drilling out that string.
2. The minimum required fill of cement behind the **9-5/8** inch intermediate casing, which shall be set at approximately **3375** feet, is:
 - Cement to surface. If cement does not circulate see B.1.a, c-d above. **Wait on cement (WOC) time for a primary cement job is to include the lead cement slurry due to cave/karst.**

If 75% or greater lost circulation occurs while drilling the intermediate casing hole, the cement on the production casing must come to surface.

3. The minimum required fill of cement behind the 5-1/2 inch production casing is:

Operator has proposed DV tool at depth of 5500'. Operator is to submit sundry if DV tool depth varies by more than 100' from approved depth.

a. First stage to DV tool:

Cement to circulate. If cement does not circulate, contact the appropriate BLM office before proceeding with second stage cement job. Operator should have plans as to how they will achieve approved top of cement on the next stage.

b. Second stage above DV tool:

Cement should tie-back at least 300 feet into previous casing string. Operator shall provide method of verification. **Excess calculates to 21% - Additional cement may be required.**

4. If hardband drill pipe is rotated inside casing, returns will be monitored for metal. If metal is found in samples, drill pipe will be pulled and rubber protectors which have a larger diameter than the tool joints of the drill pipe will be installed prior to continuing drilling operations.

C. PRESSURE CONTROL

1. All blowout preventer (BOP) and related equipment (BOPE) shall comply with well control requirements as described in Onshore Oil and Gas Order No. 2 and API RP 53 Sec. 17.

2. **Operator has proposed a multi-bowl wellhead assembly that has a weld on head with no o-ring seals. This assembly will only be tested when installed on the surface casing. Minimum working pressure of the blowout preventer (BOP) and related equipment (BOPE) required for drilling below the surface casing shoe shall be 3000 (3M) psi.**

a. **Wellhead manufacturer is supplying the test plug/retrieval tool for the operator's third party tester to use during the BOP/BOPE test. Operator shall use the supplied test plug/retrieval tool.**

b. **Operator shall install the wear bushing required by the wellhead manufacturer. This wear bushing shall be installed by using the test plug/retrieval tool.**

- c. **Wellhead manufacturer representative shall be on location when the intermediate casing mandrel is landed. Operator shall submit copy of manufacturer's wellsite report with subsequent report.**
 - d. **Operator shall perform the intermediate casing integrity test to 70% of the casing burst. This will test the multi-bowl seals.**
 - e. **If the cement does not circulate and one inch operations would have been possible with a standard wellhead, the well head shall be cut off, cementing operations performed and another wellhead installed.**
3. The appropriate BLM office shall be notified a minimum of 4 hours in advance for a representative to witness the tests.
- a. In a water basin, for all casing strings utilizing slips, these are to be set as soon as the crew and rig are ready and any fallback-cement remediation has been done. The casing cut-off and BOP installation can be initiated four hours after installing the slips, which will be approximately six hours after bumping the plug. For those casing strings not using slips, the minimum wait time before cut-off is eight hours after bumping the plug. BOP/BOPE testing can begin after cut-off or once cement reaches 500 psi compressive strength (including lead when specified), whichever is greater. However, if the float does not hold, cut-off cannot be initiated until cement reaches 500 psi compressive strength (including lead when specified).
 - b. The tests shall be done by an independent service company utilizing a test plug **not a cup or J-packer.**
 - c. The test shall be run on a 5000 psi chart for a 2-3M BOP/BOP, on a 10000 psi chart for a 5M BOP/BOPE and on a 15000 psi chart for a 10M BOP/BOPE. If a linear chart is used, it shall be a one hour chart. A circular chart shall have a maximum 2 hour clock.
 - d. The results of the test shall be reported to the appropriate BLM office.
 - e. All tests are required to be recorded on a calibrated test chart. **A copy of the BOP/BOPE test chart and a copy of independent service company test will be submitted to the appropriate BLM office.**
 - f. The BOP/BOPE test shall include a low pressure test from 250 to 300 psi. The test will be held for a minimum of 10 minutes if test is done with a test plug and 30 minutes without a test plug. This test shall be performed prior to the test at full stack pressure.

D. DRILL STEM TEST

If drill stem tests are performed, Onshore Order 2.III.D shall be followed.

E. WASTE MATERIAL AND FLUIDS

All waste (i.e. drilling fluids, trash, salts, chemicals, sewage, gray water, etc.) created as a result of drilling operations and completion operations shall be safely contained and disposed of properly at a waste disposal facility. No waste material or fluid shall be disposed of on the well location or surrounding area.

Porto-johns and trash containers will be on-location during fracturing operations or any other crew-intensive operations.

JAM 032614

VIII. PRODUCTION (POST DRILLING)

A. WELL STRUCTURES & FACILITIES

Placement of Production Facilities

Production facilities should be placed on the well pad to allow for maximum interim recontouring and revegetation of the well location.

Exclosure Netting (Open-top Tanks)

Immediately following active drilling or completion operations, the operator will take actions necessary to prevent wildlife and livestock access, including avian wildlife, to all open-topped tanks that contain or have the potential to contain salinity sufficient to cause harm to wildlife or livestock, hydrocarbons, or Resource Conservation and Recovery Act of 1976-exempt hazardous substances. At a minimum, the operator will net, screen, or cover open-topped tanks to exclude wildlife and livestock and prevent mortality. If the operator uses netting, the operator will cover and secure the open portion of the tank to prevent wildlife entry. The operator will net, screen, or cover the tanks until the operator removes the tanks from the location or the tanks no longer contain substances that could be harmful to wildlife or livestock. Use a maximum netting mesh size of 1 ½ inches. The netting must not be in contact with fluids and must not have holes or gaps.

Chemical and Fuel Secondary Containment and Exclosure Screening

The operator will prevent all hazardous, poisonous, flammable, and toxic substances from coming into contact with soil and water. At a minimum, the operator will install and maintain an impervious secondary containment system for any tank or barrel containing hazardous, poisonous, flammable, or toxic substances sufficient to contain the contents of the tank or barrel and any drips, leaks, and anticipated precipitation. The operator will dispose of fluids within the containment system that do not meet applicable state or U. S. Environmental Protection Agency livestock water standards in accordance with state law; the operator must not drain the fluids to the soil or ground. The operator will design, construct, and maintain all secondary containment systems to prevent wildlife and livestock exposure to harmful substances. At a minimum, the operator will install effective wildlife and livestock exclosure systems such as fencing, netting, expanded metal mesh, lids, and grate covers. Use a maximum netting mesh size of 1 ½ inches.

Open-Vent Exhaust Stack Exclosures

The operator will construct, modify, equip, and maintain all open-vent exhaust stacks on production equipment to prevent birds and bats from entering, and to discourage perching, roosting, and nesting. (*Recommended exclosure structures on open-vent exhaust stacks are in the shape of a cone.*) Production equipment includes, but may not be limited to, tanks, heater-treaters, separators, dehydrators, flare stacks, in-line units, and compressor mufflers.

Containment Structures

Proposed production facilities such as storage tanks and other vessels will have a secondary containment structure that is constructed to hold the capacity of 1.5 times the

largest tank, plus freeboard to account for precipitation, unless more stringent protective requirements are deemed necessary.

Painting Requirement

All above-ground structures including meter housing that are not subject to safety requirements shall be painted a flat non-reflective paint color, **Shale Green** from the BLM Standard Environmental Color Chart (CC-001: June 2008).

B. PIPELINES

BURIED PIPELINE STIPULATIONS

A copy of the application (Grant, APD, or Sundry Notice) and attachments, including conditions of approval, survey plat and/or map, will be on location during construction. BLM personnel may request to you a copy of your permit during construction to ensure compliance with all stipulations.

Holder agrees to comply with the following stipulations to the satisfaction of the Authorized Officer:

1. The Holder shall indemnify the United States against any liability for damage to life or property arising from the occupancy or use of public lands under this grant.
2. The Holder shall comply with all applicable Federal laws and regulations existing or hereafter enacted or promulgated. In any event, the holder shall comply with the Toxic Substances Control Act of 1976 as amended, 15 USC 2601 et seq. (1982) with regards to any toxic substances that are used, generated by or stored on the right-of-way or on facilities authorized under this right-of-way grant. (See 40 CFR Part 702-799 and especially, provisions on polychlorinated biphenyls, 40 CFR 761.1-761.193.) Additionally, any release of toxic substances (leaks, spills, etc.) in excess of the reportable quantity established by 40 CFR Part 117 shall be reported as required by the Comprehensive Environmental Response, Compensation, and Liability Act, section 102b. A copy of any report required or requested by any Federal agency or State government as a result of a reportable release or spill of any toxic substances shall be furnished to the authorized officer concurrent with the filing of the reports to the involved Federal agency or State government.
3. The holder agrees to indemnify the United States against any liability arising from the release of any hazardous substance or hazardous waste (as these terms are defined in the Comprehensive Environmental Response, Compensation and Liability Act of 1980, 42 U.S.C. 9601, et seq. or the Resource Conservation and Recovery Act, 42 U.S.C. 6901, et seq.) on the Right-of-Way (unless the release or threatened release is wholly unrelated to the Right-of-Way holder's activity on the Right-of-Way), or resulting from the activity of the Right-of-Way holder on the Right-of-Way. This agreement applies without regard to whether a release is caused by the holder, its agent, or unrelated third parties.
4. If, during any phase of the construction, operation, maintenance, or termination of the pipeline, any oil or other pollutant should be discharged from the pipeline system, impacting Federal lands, the control and total removal, disposal, and cleaning up of such oil or other pollutant, wherever found, shall be the responsibility of holder, regardless of fault. Upon failure

of holder to control, dispose of, or clean up such discharge on or affecting Federal lands, or to repair all damages resulting therefrom, on the Federal lands, the Authorized Officer may take such measures as he deems necessary to control and clean up the discharge and restore the area, including where appropriate, the aquatic environment and fish and wildlife habitats, at the full expense of the holder. Such action by the Authorized Officer shall not relieve holder of any responsibility as provided herein.

5. All construction and maintenance activity will be confined to the authorized right-of-way.

6. The pipeline will be buried with a minimum cover of 36 inches between the top of the pipe and ground level.

7. The maximum allowable disturbance for construction in this right-of-way will be 30 feet:

- Blading of vegetation within the right-of-way will be allowed: maximum width of blading operations will not exceed 20 feet. The trench is included in this area. (*Blading is defined as the complete removal of brush and ground vegetation.*)
- Clearing of brush species within the right-of-way will be allowed: maximum width of clearing operations will not exceed 30 feet. The trench and bladed area are included in this area. (*Clearing is defined as the removal of brush while leaving ground vegetation (grasses, weeds, etc.) intact. Clearing is best accomplished by holding the blade 4 to 6 inches above the ground surface.*)
- The remaining area of the right-of-way (if any) shall only be disturbed by compressing the vegetation. (*Compressing can be caused by vehicle tires, placement of equipment, etc.*)

8. The holder shall stockpile an adequate amount of topsoil where blading is allowed. The topsoil to be stripped is approximately 6 inches in depth. The topsoil will be segregated from other spoil piles from trench construction. The topsoil will be evenly distributed over the bladed area for the preparation of seeding.

9. The holder shall minimize disturbance to existing fences and other improvements on public lands. The holder is required to promptly repair improvements to at least their former state. Functional use of these improvements will be maintained at all times. The holder will contact the owner of any improvements prior to disturbing them. When necessary to pass through a fence line, the fence shall be braced on both sides of the passageway prior to cutting of the fence. No permanent gates will be allowed unless approved by the Authorized Officer.

10. Vegetation, soil, and rocks left as a result of construction or maintenance activity will be randomly scattered on this right-of-way and will not be left in rows, piles, or berms, unless otherwise approved by the Authorized Officer. The entire right-of-way shall be recontoured to match the surrounding landscape. The backfilled soil shall be compacted and a 6 inch berm will be left over the ditch line to allow for settling back to grade.

11. In those areas where erosion control structures are required to stabilize soil conditions, the holder will install such structures as are suitable for the specific soil conditions being encountered and which are in accordance with sound resource management practices.

12. The holder will reseed all disturbed areas. Seeding will be done according to the attached seeding requirements, using the following seed mix.

- | | |
|---|--|
| <input type="checkbox"/> seed mixture 1 | <input type="checkbox"/> seed mixture 3 |
| <input type="checkbox"/> seed mixture 2 | <input checked="" type="checkbox"/> seed mixture 4 |
| <input type="checkbox"/> seed mixture 2/LPC | <input type="checkbox"/> Aplomado Falcon Mixture |

13. All above-ground structures not subject to safety requirements shall be painted by the holder to blend with the natural color of the landscape. The paint used shall be color which simulates "Standard Environmental Colors" – **Shale Green**, Munsell Soil Color No. 5Y 4/2.

14. The pipeline will be identified by signs at the point of origin and completion of the right-of-way and at all road crossings. At a minimum, signs will state the holder's name, BLM serial number, and the product being transported. All signs and information thereon will be posted in a permanent, conspicuous manner, and will be maintained in a legible condition for the life of the pipeline.

15. The holder shall not use the pipeline route as a road for purposes other than routine maintenance as determined necessary by the Authorized Officer in consultation with the holder before maintenance begins. The holder will take whatever steps are necessary to ensure that the pipeline route is not used as a roadway. As determined necessary during the life of the pipeline, the Authorized Officer may ask the holder to construct temporary deterrence structures.

16. Any cultural and/or paleontological resources (historic or prehistoric site or object) discovered by the holder, or any person working on his behalf, on public or Federal land shall be immediately reported to the Authorized Officer. Holder shall suspend all operations in the immediate area of such discovery until written authorization to proceed is issued by the Authorized Officer. An evaluation of the discovery will be made by the Authorized Officer to determine appropriate actions to prevent the loss of significant cultural or scientific values. The holder will be responsible for the cost of evaluation and any decision as to proper mitigation measures will be made by the Authorized Officer after consulting with the holder.

17. The operator shall be held responsible if noxious weeds become established within the areas of operations: Weed control shall be required on the disturbed land where noxious weeds exist, which includes associated roads, pipeline corridor and adjacent land affected by the establishment of weeds due to this action. The operator shall consult with the Authorized Officer for acceptable weed control methods, which include following EPA and BLM requirements and policies.

18. Escape Ramps - The operator will construct and maintain pipeline/utility trenches that are not otherwise fenced, screened, or netted to prevent livestock, wildlife, and humans from becoming entrapped. At a minimum, the operator will construct and maintain escape ramps, ladders, or other methods of avian and terrestrial wildlife escape in the trenches according to the following criteria:

- a. Any trench left open for eight (8) hours or less is not required to have escape ramps; however, before the trench is backfilled, the contractor/operator shall inspect the trench for wildlife, remove all trapped wildlife, and release them at least 100 yards from the trench.
- b. For trenches left open for eight (8) hours or more, earthen escape ramps (built at no more than a 30 degree slope and spaced no more than 500 feet apart) shall be placed in the trench.

STANDARD STIPULATIONS FOR SURFACE INSTALLED PIPELINES

A copy of the application (Grant, Sundry Notice, APD) and attachments, including stipulations, survey plat and/or map, will be on location during construction. BLM personnel may request to you a copy of your permit during construction to ensure compliance with all stipulations.

Holder agrees to comply with the following stipulations to the satisfaction of the Authorized Officer:

1. The holder shall indemnify the United States against any liability for damage to life or property arising from the occupancy or use of public lands under this grant.
2. The holder shall comply with all applicable Federal laws and regulations existing or hereafter enacted or promulgated. In any event, the holder shall comply with the Toxic Substances Control Act of 1976 as amended, 15 USC 2601 et seq. (1982) with regards to any toxic substances that are used, generated by or stored on the right-of-way or on facilities authorized under this right-of-way grant. (See 40 CFR, Part 702-799 and especially, provisions on polychlorinated biphenyls, 40 CFR 761.1-761.193.) Additionally, any release of toxic substances (leaks, spills, etc.) in excess of the reportable quantity established by 40 CFR, Part 117 shall be reported as required by the Comprehensive Environmental Response, Compensation, and Liability Act, section 102b. A copy of any report required or requested by any Federal agency or State government as a result of a reportable release or spill of any toxic substances shall be furnished to the authorized officer concurrent with the filing of the reports to the involved Federal agency or State government.
3. The holder agrees to indemnify the United States against any liability arising from the release of any hazardous substance or hazardous waste (as these terms are defined in the Comprehensive Environmental Response, Compensation and Liability Act of 1980, 42 U.S.C. 9601, et seq. or the Resource Conservation and Recovery Act, 42 U.S.C. 6901, et seq.) on the Right-of-Way (unless the release or threatened release is wholly unrelated to activity of the Right-of-Way holder's activity on the Right-of-Way), or resulting from the activity of the Right-of-Way holder on the Right-of-Way. This agreement applies without regard to whether a release is caused by the holder, its agent, or unrelated third parties.
4. The holder shall be liable for damage or injury to the United States to the extent provided by 43 CFR Sec. 2883.1-4. The holder shall be held to a standard of strict liability for damage or injury to the United States resulting from pipe rupture, fire, or spills caused or substantially aggravated by any of the following within the right-of-way or permit area:
 - a. Activities of the holder including, but not limited to construction, operation, maintenance, and termination of the facility.
 - b. Activities of other parties including, but not limited to:
 - (1) Land clearing.

- (2) Earth-disturbing and earth-moving work.
- (3) Blasting.
- (4) Vandalism and sabotage.

c. Acts of God.

The maximum limitation for such strict liability damages shall not exceed one million dollars (\$1,000,000) for any one event, and any liability in excess of such amount shall be determined by the ordinary rules of negligence of the jurisdiction in which the damage or injury occurred.

This section shall not impose strict liability for damage or injury resulting primarily from an act of war or from the negligent acts or omissions of the United States.

5. If, during any phase of the construction, operation, maintenance, or termination of the pipeline, any oil, salt water, or other pollutant should be discharged from the pipeline system, impacting Federal lands, the control and total removal, disposal, and cleaning up of such oil, salt water, or other pollutant, wherever found, shall be the responsibility of the holder, regardless of fault. Upon failure of the holder to control, dispose of, or clean up such discharge on or affecting Federal lands, or to repair all damages resulting therefrom, on the Federal lands, the Authorized Officer may take such measures as he deems necessary to control and clean up the discharge and restore the area, including, where appropriate, the aquatic environment and fish and wildlife habitats, at the full expense of the holder. Such action by the Authorized Officer shall not relieve the holder of any responsibility as provided herein.

6. All construction and maintenance activity will be confined to the authorized right-of-way width of 20 feet. If the pipeline route follows an existing road or buried pipeline right-of-way, the surface pipeline must be installed no farther than 10 feet from the edge of the road or buried pipeline right-of-way. If existing surface pipelines prevent this distance, the proposed surface pipeline must be installed immediately adjacent to the outer surface pipeline. All construction and maintenance activity will be confined to existing roads or right-of-ways.

7. No blading or clearing of any vegetation will be allowed unless approved in writing by the Authorized Officer.

8. The holder shall install the pipeline on the surface in such a manner that will minimize suspension of the pipeline across low areas in the terrain. In hummocky or dune areas, the pipeline will be "snaked" around hummocks and dunes rather than suspended across these features.

9. The pipeline shall be buried with a minimum of 24 inches under all roads, "two-tracks," and trails. Burial of the pipe will continue for 20 feet on each side of each crossing. The condition of the road, upon completion of construction, shall be returned to at least its former state with no bumps or dips remaining in the road surface.

10. The holder shall minimize disturbance to existing fences and other improvements on public lands. The holder is required to promptly repair improvements to at least their former state. Functional use of these improvements will be maintained at all times. The holder will contact the owner of any improvements prior to disturbing them. When necessary to pass through a fence line, the fence shall be braced on both sides of the passageway prior to cutting of the fence. No permanent gates will be allowed unless approved by the Authorized Officer.

11. In those areas where erosion control structures are required to stabilize soil conditions, the holder will install such structures as are suitable for the specific soil conditions being encountered and which are in accordance with sound resource management practices.

12. Excluding the pipe, all above-ground structures not subject to safety requirement shall be painted by the holder to blend with the natural color of the landscape. The paint used shall be a color which simulates "Standard Environmental Colors" – **Shale Green**, Munsell Soil Color No. 5Y 4/2; designated by the Rocky Mountain Five State Interagency Committee.

13. The pipeline will be identified by signs at the point of origin and completion of the right-of-way and at all road crossings. At a minimum, signs will state the holder's name, BLM serial number, and the product being transported. Signs will be maintained in a legible condition for the life of the pipeline.

14. The holder shall not use the pipeline route as a road for purposes other than routine maintenance as determined necessary by the Authorized Officer in consultation with the holder. The holder will take whatever steps are necessary to ensure that the pipeline route is not used as a roadway.

15. Any cultural and/or paleontological resource (historic or prehistoric site or object) discovered by the holder, or any person working on his behalf, on public or Federal land shall be immediately reported to the authorized officer. Holder shall suspend all operations in the immediate area of such discovery until written authorization to proceed is issued by the authorized officer. An evaluation of the discovery will be made by the authorized officer to determine appropriate cultural or scientific values. The holder will be responsible for the cost of evaluation and any decision as to proper mitigation measures will be made by the authorized officer after consulting with the holder.

16. The operator shall be held responsible if noxious weeds become established within the areas of operations. Weed control shall be required on the disturbed land where noxious weeds exist, which includes the roads, powerline corridor, and adjacent land affected by the establishment of weeds due to this action. The operator shall consult with the Authorized Officer for acceptable weed control methods, which include following EPA and BLM requirements and policies.

17. Surface pipelines must be less than or equal to 4 inches and a working pressure below 125 psi.

C. ELECTRIC LINES
STANDARD STIPULATIONS FOR OVERHEAD ELECTRIC DISTRIBUTION LINES

A copy of the grant and attachments, including stipulations, survey plat and/or map, will be on location during construction. BLM personnel may request to you a copy of your permit during construction to ensure compliance with all stipulations.

Holder agrees to comply with the following stipulations to the satisfaction of the Authorized Officer:

1. The holder shall indemnify the United States against any liability for damage to life or property arising from the occupancy or use of public lands under this grant.
2. The holder shall comply with all applicable Federal laws and regulations existing or hereafter-enacted or promulgated. In any event, the holder shall comply with the Toxic Substances Control Act of 1976 as amended, 15 USC 2601 et seq. (1982) with regards to any toxic substances that are used, generated by or stored on the right-of-way or on facilities authorized under this right-of-way grant. (See 40 CFR, Part 702-799 and especially, provisions on polychlorinated biphenyls, 40 CFR 761.1-761.193.) Additionally, any release of toxic substances (leaks, spills, etc.) in excess of the reportable quantity established by 40 CFR, Part 117 shall be reported as required by the Comprehensive Environmental Response, Compensation, and Liability Act, section 102b. A copy of any report required or requested by any Federal agency or State government as a result of a reportable release or spill of any toxic substances shall be furnished to the authorized officer concurrent with the filing of the reports to the involved Federal agency or State government.
3. The holder agrees to indemnify the United States against any liability arising from the release of any hazardous substance or hazardous waste (as these terms are defined in the Comprehensive Environmental Response, Compensation and Liability Act of 1980, 42 U.S.C. 9601, et seq. or the Resource Conservation and Recovery Act, 42 U.S.C. 6901, et seq.) on the Right-of-Way (unless the release or threatened release is wholly unrelated to the Right-of-Way holder's activity on the Right-of-Way), or resulting from the activity of the Right-of-Way holder on the Right-of-Way. This agreement applies without regard to whether a release is caused by the holder, its agent, or unrelated third parties.
4. There will be no clearing or blading of the right-of-way unless otherwise agreed to in writing by the Authorized Officer.
5. Power lines shall be constructed and designed in accordance to standards outlined in "Suggested Practices for Avian Protection on Power lines: The State of the Art in 2006"

Edison Electric Institute, APLIC, and the California Energy Commission 2006. The holder shall assume the burden and expense of proving that pole designs not shown in the above publication deter raptor perching, roosting, and nesting. Such proof shall be provided by a raptor expert approved by the Authorized Officer. The BLM reserves the right to require modification or additions to all powerline structures placed on this right-of-way, should they be necessary to ensure the safety of large perching birds. Such modifications and/or additions shall be made by the holder without liability or expense to the United States.

Raptor deterrence will consist of but not limited to the following: triangle perch discouragers shall be placed on each side of the cross arms and a nonconductive perching deterrence shall be placed on all vertical poles that extend past the cross arms.

6. The holder shall minimize disturbance to existing fences and other improvements on public lands. The holder is required to promptly repair improvements to at least their former state. Functional use of these improvements will be maintained at all times. The holder will contact the owner of any improvements prior to disturbing them. When necessary to pass through a fence line, the fence shall be braced on both sides of the passageway prior to cutting the fence. No permanent gates will be allowed unless approved by the Authorized Officer.

7. The BLM serial number assigned to this authorization shall be posted in a permanent, conspicuous manner where the power line crosses roads and at all serviced facilities. Numbers will be at least two inches high and will be affixed to the pole nearest the road crossing and at the facilities served.

8. Upon cancellation, relinquishment, or expiration of this grant, the holder shall comply with those abandonment procedures as prescribed by the Authorized Officer.

9. All surface structures (poles, lines, transformers, etc.) shall be removed within 180 days of abandonment, relinquishment, or termination of use of the serviced facility or facilities or within 180 days of abandonment, relinquishment, cancellation, or expiration of this grant, whichever comes first. This will not apply where the power line extends service to an active, adjoining facility or facilities.

10. Any cultural and/or paleontological resource (historic or prehistoric site or object) discovered by the holder, or any person working on his behalf, on public or Federal land shall be immediately reported to the Authorized Officer. Holder shall suspend all operations in the immediate area of such discovery until written authorization to proceed is issued by the Authorized Officer. An evaluation of the discovery will be made by the Authorized Officer to determine appropriate actions to prevent the loss of significant cultural or scientific values. The holder will be responsible for the cost of evaluation and any decision as to proper mitigation measures will be made by the Authorized Officer after consulting with the holder.

11. Special Stipulations:

- For reclamation remove poles, lines, transformer, etc. and dispose of properly.
- Fill in any holes with native soil.

IX. INTERIM RECLAMATION

During the life of the development, all disturbed areas not needed for active support of production operations should undergo interim reclamation in order to minimize the environmental impacts of development on other resources and uses.

Within six (6) months of well completion, operators should work with BLM surface management specialists (Jim Amos: 575-234-5909) to devise the best strategies to reduce the size of the location. Interim reclamation should allow for remedial well operations, as well as safe and efficient removal of oil and gas.

During reclamation, the removal of caliche is important to increasing the success of revegetating the site. Removed caliche that is free of contaminants may be used for road repairs, fire walls or for building other roads and locations. In order to operate the well or complete workover operations, it may be necessary to drive, park and operate on restored interim vegetation within the previously disturbed area. Disturbing revegetated areas for production or workover operations will be allowed. If there is significant disturbance and loss of vegetation, the area will need to be revegetated. Communicate with the appropriate BLM office for any exceptions/exemptions if needed.

All disturbed areas after they have been satisfactorily prepared need to be reseeded with the seed mixture provided below.

Upon completion of interim reclamation, the operator shall submit a Sundry Notices and Reports on Wells, Subsequent Report of Reclamation (Form 3160-5).

X. FINAL ABANDONMENT & RECLAMATION

At final abandonment, well locations, production facilities, and access roads must undergo "final" reclamation so that the character and productivity of the land are restored.

Earthwork for final reclamation must be completed within six (6) months of well plugging. All pads, pits, facility locations and roads must be reclaimed to a satisfactory revegetated, safe, and stable condition, unless an agreement is made with the landowner or BLM to keep the road and/or pad intact.

After all disturbed areas have been satisfactorily prepared, these areas need to be revegetated with the seed mixture provided below. Seeding should be accomplished by drilling on the contour whenever practical or by other approved methods. Seeding may need to be repeated until revegetation is successful, as determined by the BLM.

Operators shall contact a BLM surface protection specialist prior to surface abandonment operations for site specific objectives (Jim Amos: 575-234-5909).

Seed Mixture 4, for Gypsum Sites

The holder shall seed all disturbed areas with the seed mixture listed below. The seed mixture shall be planted in the amounts specified in pounds of pure live seed (PLS)* per acre. There shall be no primary or secondary noxious weeds in the seed mixture. Seed will be tested and the viability testing of seed will be done in accordance with State law(s) and within nine (9) months prior to purchase. Commercial seed will be either certified or registered seed. The seed container will be tagged in accordance with State law(s) and available for inspection by the authorized officer.

Seed will be planted using a drill equipped with a depth regulator to ensure proper depth of planting where drilling is possible. The seed mixture will be evenly and uniformly planted over the disturbed area (smaller/heavier seeds have a tendency to drop the bottom of the drill and are planted first). The holder shall take appropriate measures to ensure this does not occur. Where drilling is not possible, seed will be broadcast and the area shall be raked or chained to cover the seed. When broadcasting the seed, the pounds per acre are to be doubled. The seeding will be repeated until a satisfactory stand is established as determined by the authorized officer. Evaluation of growth will not be made before completion of at least one full growing season after seeding.

Species to be planted in pounds of pure live seed* per acre:

<u>Species</u>	<u>lb/acre</u>
Alkali Sacaton (Sporobolus airoides)	1.0
DWS □ Four-wing saltbush (Atriplex canescens)	5.0

DWS: DeWinged Seed

*Pounds of pure live seed:

Pounds of seed x percent purity x percent germination = pounds pure live seed