

RECEIVED

Form 3160-5  
(April 2004)

UNITED STATES  
DEPARTMENT OF THE INTERIOR  
BUREAU OF LAND MANAGEMENT

OCD-HOBSO 23 2010

FORM APPROVED  
OMB No. 1004-0137  
Expires: March 31, 2007

HOBSO

SUNDRY NOTICES AND REPORTS ON WELLS

Do not use this form for proposals to drill or to re-enter an abandoned well. Use Form 3160-3 (APD) for such proposals.

5. Lease Serial No.  
NM 06413

6. If Indian, Allottee or Tribe Name

7. If Unit or CA/Agreement, Name and/or No.

SUBMIT IN TRIPLICATE- Other instructions on reverse side.

1. Type of Well  
 Oil Well  Gas Well  Other INJECTION SWD

8. Well Name and No.  
CACTUS FEDERAL #3

2. Name of Operator  
TANDEM ENERGY CORPORATION

9. API Well No.  
30-025-03335

3a. Address 11490 Westheimer Rd Suite 100  
Houston TX 77077

3b. Phone No. (include area code)  
(281) 649-4500

10. Field and Pool, or Exploratory Area  
Pearl Queen SWD

4. Location of Well (Footage, Sec., T., R., M., or Survey Description)  
330 FWL 660 PWL UNIT LETTER "D"  
NW/4 Sec. 6 T20S R35E

11. County or Parish, State  
Lea, NM.

12. CHECK APPROPRIATE BOX(ES) TO INDICATE NATURE OF NOTICE, REPORT, OR OTHER DATA

TYPE OF SUBMISSION	TYPE OF ACTION			
<input type="checkbox"/> Notice of Intent	<input checked="" type="checkbox"/> Acidize	<input type="checkbox"/> Deepen	<input type="checkbox"/> Production (Start/Resume)	<input type="checkbox"/> Water Shut-Off
<input checked="" type="checkbox"/> Subsequent Report	<input type="checkbox"/> Alter Casing	<input type="checkbox"/> Fracture Treat	<input type="checkbox"/> Reclamation	<input type="checkbox"/> Well Integrity
<input type="checkbox"/> Final Abandonment Notice	<input type="checkbox"/> Casing Repair	<input type="checkbox"/> New Construction	<input type="checkbox"/> Recomplete	<input type="checkbox"/> Other
	<input type="checkbox"/> Change Plans	<input type="checkbox"/> Plug and Abandon	<input type="checkbox"/> Temporarily Abandon	
	<input type="checkbox"/> Convert to Injection	<input type="checkbox"/> Plug Back	<input type="checkbox"/> Water Disposal	

13. Describe Proposed or Completed Operation (clearly state all pertinent details, including estimated starting date of any proposed work and approximate duration thereof. If the proposal is to deepen directionally or recomplate horizontally, give subsurface locations and measured and true vertical depths of all pertinent markers and zones. Attach the Bond under which the work will be performed or provide the Bond No. on file with BLM/BIA. Required subsequent reports shall be filed within 30 days following completion of the involved operations. If the operation results in a multiple completion or recomplate in a new interval, a Form 3160-4 shall be filed once testing has been completed. Final Abandonment Notices shall be filed only after all requirements, including reclamation, have been completed, and the operator has determined that the site is ready for final inspection.)

10-28-2010 MURU NU BOP + ENVIROVAT. Ref. RFR. POOH w/ f. R/H w/ Tbg Tagged @ 4979. POOH S/I

10-29-2010 R/H w/ PFR + Tbg. set PFR @ 4565' load csg. RV Acid Trucks. Acidize w/ 3000 gals of 21% NEFE Acid + 1500# Rock Salt @ 3 BPM Max Pressure 1000 psi. Flush to bottom, S/I for 2 hrs. Flow well back S/I

10-30-2010 Open well up. no pressure. POOH w/ PFR. R/H w/ Tbg circulate well clean. POOH.

11-1-2010 R/H w/ 4 1/2 Arrow set PFR circulate PFR fluid. set PFR @ 4562' test csg to scoopst.

14. I hereby certify that the foregoing is true and correct

Name (Printed/Typed)  
Jose Cerrillo

Signature  
Jose Cerrillo

Title  
field supervisor

Date  
11-2-2010

ACCEPTED FOR RECORD

THIS SPACE FOR FEDERAL OR STATE OFFICE USE

Approved by  
OC FIELD REPRESENTATIVE  
Conditions of approval, if any, are attached. Approval of this notice does not warrant or certify that the applicant holds legal or equitable title to those rights in the subject lease which would entitle the applicant to conduct operations thereon.

Staff Manager

Date  
NOV 20 2010

BUREAU OF LAND MANAGEMENT  
CARLSBAD FIELD OFFICE

Title 18 U.S.C. Section 1001 and Title 43 U.S.C. Section 1212, make it a crime for any person knowingly and willfully to make to any department or agency of the United States any false, fictitious or fraudulent statements or representations as to any matter within its jurisdiction.

(Instructions on page 2)

NOV 23 2010

CACTUS FEDERAL #3 (INJ.)

TANDEM ENERGY corporation

TBG. SIZE: 2 3/8" IPC

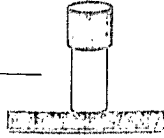

WELLBORE

Spudded: \_\_\_\_\_

Completed: \_\_\_\_\_

API #: 30-025-03335

Wellhead size: 8 5/8"

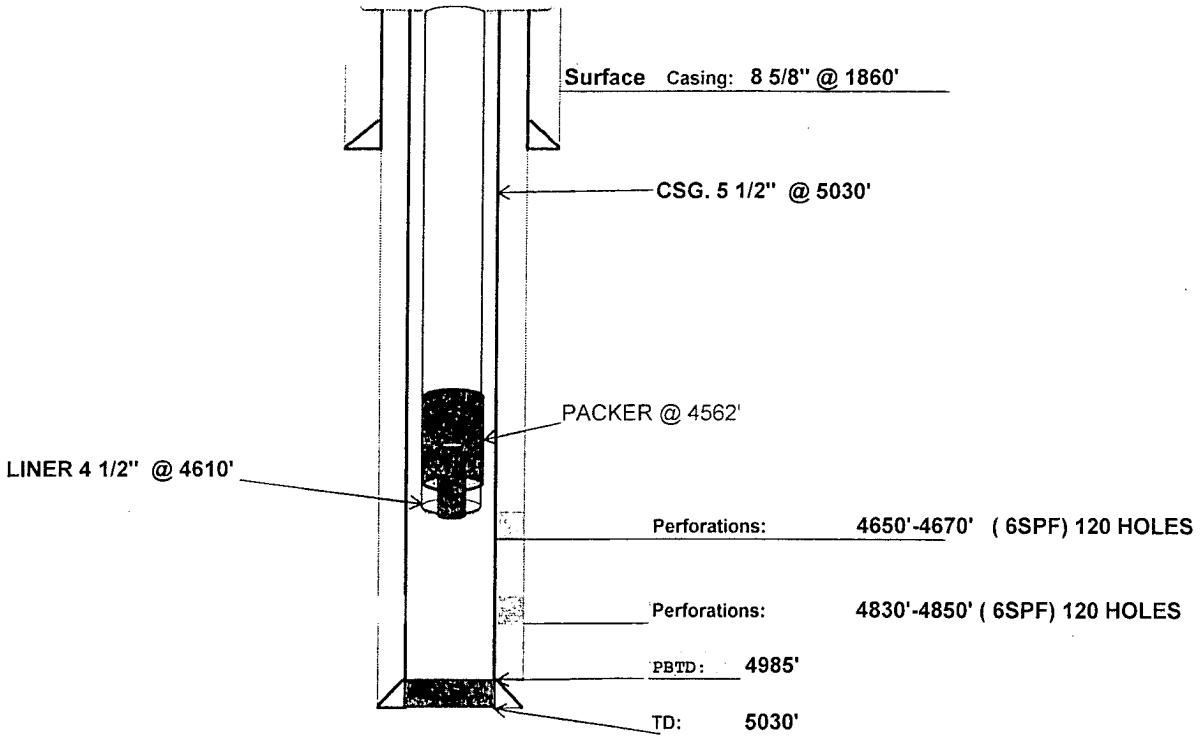

Remarks:

---

---

---

---

---